



# **Zimbra™ Collaboration Suite Advanced Web Client User Guide**

---

Version 5.0



## Copyright Notice

Copyright © 2008 Zimbra, Inc. All rights reserved.

This document contains confidential, proprietary information of Zimbra, Inc. Unauthorized copying, reproduction, or disclosure of any portion of the contents of these materials by any means—including printed or duplicated materials, on-screen publication, or Web documentation—is expressly forbidden.

Zimbra and the Zimbra logo are trademarks of Zimbra Inc. Any other trademarks are the property of their respective owners.

Release ZWC 5.0

Released 6/03/2008



---

---

## About this Guide

### Conventions Used

The following icons will be used in the End User Guide:

Icon	Description
	Important concept
	Note
	Tip for success



# Table of Contents

<b>About this Guide</b> .....	<b>3</b>
Conventions Used .....	3
<b>1 Getting Started with the Zimbra Web Client</b> .....	<b>11</b>
Advanced and Standard ZWC .....	11
Features of the Zimbra Web Client (ZWC).....	12
Zimbra Web Client Components .....	14
Browser Compatibility.....	17
Logging In.....	17
Forget your password? .....	18
If Your Session Expires .....	19
Navigating the Zimbra Web Client .....	19
User Interface Features and Shortcuts .....	21
Zimbra Assistant.....	23
ZWC Keyboard Shortcut Keys .....	25
<b>2 Receiving and Managing Email</b> .....	<b>27</b>
Customizing Your Initial Email Page .....	27
Email Views.....	28
Parts of the Content Page View .....	29
How Do Conversations Work? .....	30
Reading Email .....	31
The Reading Pane .....	32
Displaying HTML in Email Messages .....	33
Parts of an Email message .....	34
Viewing an Attachment .....	35
Marking an Email as Unread.....	36
Virus Safety .....	37
Printing an Email Message.....	37
Organizing Email Messages Using Folders .....	39
Mail System Folders Overview.....	39
Sharing Your Mail Folders.....	40
Moving Email Messages .....	41
Sorting Messages in the Content Pane .....	42
Deleting a Message: The Trash Folder.....	42
Purging an Email Message from the Trash Folder .....	42
Managing Junk Email & Spam: The Junk Folder.....	43
<b>3 Composing and Sending Email</b> .....	<b>45</b>
Composing a New Email Message .....	45
Cc and Bcc Addresses.....	47
Using HTML Editor.....	48
Using Spell Check.....	49



Adding an Attachment.....	50
Attachment File Types Supported.....	51
Automatic Address Completion.....	53
Using Autocomplete.....	54
Saving Your Work.....	54
Saving Messages You Send: The Sent Folder.....	55
Replying to an Email Message.....	56
Forwarding an Email Message.....	57
Optional Email Features.....	58
Email Signatures.....	58
Undeliverable Email.....	60
Setting a Forwarding Address.....	61
<b>4 Using Tags and Folders to Organize Your Mailbox.....</b>	<b>63</b>
Working with Tags.....	63
Creating Tags.....	63
Assigning a Tag to Messages and Other Items.....	66
Deleting a Tag.....	68
Flagging an Email Message.....	69
Using Folders: General Techniques.....	69
Creating a Custom Folder.....	70
Renaming a Folder.....	71
Deleting a Folder.....	72
<b>5 Create Filters to Automate Email Handling.....</b>	<b>75</b>
Filter Conditions & Actions.....	75
Using Any and All.....	77
When Filters are Used.....	77
Filter Order.....	77
Creating a Filter.....	77
Creating a Filter from the Mail Filters Tab.....	78
Creating a Filter from an Email Message.....	81
Editing a Filter.....	82
Filter Conditions and Actions Supported.....	82
Conditions.....	82
Actions.....	85
Multiple Actions.....	86
Filter Wildcards.....	86
Asterisk (*).....	86
Question Mark (?).....	87
Escape Character is Slash: \.....	87



---

<b>6</b>	<b>Customizing Your Email Features</b>	<b>89</b>
	Setting a New Email Notification	89
	Creating an Away Message	90
	Managing Your Account Identities	91
	Creating a Persona	92
	Retrieving Email from an External Account	94
	Information You Need	95
	Receiving Messages from Your External Account	95
	Adding an External Account	96
	Subscribe to an RSS	98
	Mailbox Quotas	100
	Changing Your Default Time Zone	101
<b>7</b>	<b>Managing Your Address Books</b>	<b>103</b>
	Viewing Your Contact Information	103
	Adding a New Contact	105
	Adding a new contact from the toolbar	105
	Adding a new contact from an existing email message	106
	Adding Names to Email from an Address Book	108
	Adding Contacts Automatically	110
	Creating a Group Contact List	110
	Importing an Address Book	112
	Exporting an Address Book	113
	Printing a Contact Name or Address Book	114
	Editing Contact Information	115
	Deleting Contacts	116
	Sharing Your Address Books	117
<b>8</b>	<b>Managing Your Calendar</b>	<b>119</b>
	Displaying the Calendar View	119
	Creating a Calendar	119
	Adding Color to a Calendar	122
	Viewing Multiple Calendars	122
	Importing Your iCal Calendar	124
	Exporting Your iCal Calendar	124
	Sharing Your Calendars	126
	Printing a Calendar	126
	Deleting a Calendar	127
<b>9</b>	<b>Scheduling Appointments, Meetings, and Events</b>	<b>129</b>
	Creating an Appointment or Meeting	129
	Opening the Appointment Details Tab	130
	Opening the QuickAdd Appointment Dialog	131
	Creating a QuickAdd Appointment	132
	Creating a Meeting Using the Appointment Details Tab	134

---



Scheduling Attendees: The Find Attendees Tab.....	138
Viewing Free/Busy Times: The Schedule Tab.....	139
Scheduling a Location: The Find Locations Tab.....	140
Scheduling Resources: The Find Resources Tab.....	141
Scheduling an All Day Event.....	142
Creating a Recurring Appointment.....	143
Changing an Appointment or Meeting.....	145
Deleting an Appointment or Meeting.....	146
Deleting a Meeting.....	146
Deleting a Recurring Meeting.....	148
Printing an Appointment or Meeting.....	148
Creating a Meeting Using Drag and Drop: Turning a Message or Contact into a Meeting Request.....	149
Turning a Message or Conversation into a Meeting Request.....	149
Turning a Contact into a Meeting Request.....	150
Responding to a Meeting Invitation.....	151
Changing Your Response to a Meeting Invitation.....	153
<b>10 Using the Preferences Tabs.....</b>	<b>155</b>
Saving, Canceling, and Reverting Changes to Preferences.....	155
General Tab.....	156
Mail Tab.....	157
Composing Messages Tab.....	159
Signatures Tab.....	161
Address Book Tab.....	162
Accounts Tab.....	163
Mail Filters Tab.....	163
Calendar Tab.....	164
Shortcuts Tab.....	165
<b>11 Using Task Lists.....</b>	<b>167</b>
Creating a New Task List.....	167
Creating a New Task.....	168
Adding a Task Quickly.....	171
Changing or Updating a Task.....	172
Moving a Task.....	173
Deleting a Task.....	175
Sorting Tasks.....	175
Sharing Task Lists.....	176
<b>12 Working in Documents.....</b>	<b>177</b>
Creating a New Notebook.....	177
Creating a New Page.....	179
Formatting a Notebook Page: Overview.....	180



Formatting a Page Using the Rich-Text Editor .....	181
Formatting Using HTML Source .....	185
Sharing Your Documents Notebooks .....	185
<b>13 Briefcase .....</b>	<b>187</b>
Creating Briefcase Folders .....	187
Adding Files to Your Briefcase Folders .....	188
Viewing Files in Briefcase .....	189
Working in Briefcase .....	191
Opening files in Briefcase .....	191
Moving files .....	191
Tag files .....	191
Send an email with a link to a file .....	192
Sharing Your Briefcase Folders .....	192
<b>14 Searching Your Account .....</b>	<b>193</b>
Search Syntax .....	193
Using Quick-Search .....	194
Advanced Search Criteria .....	195
Searching for Messages with Quick Search .....	196
Searching for Messages with Advanced Search .....	197
Advanced Search Example .....	198
Using * as a Wildcard in Search .....	199
Saving a Search Query .....	199
Search Examples .....	200
<b>15 Sharing Your Account Folders .....</b>	<b>203</b>
Selecting Access Privileges .....	203
How Sharing Works .....	204
Sharing Your Mail Folders .....	205
Sharing Address Book Contact Lists .....	205
Sharing Calendars .....	206
Sharing Task Lists, Documents Notebooks, Briefcase Folders .....	206
Setting Up Shared Folders .....	206
Changing or Cancelling Access .....	207
Accepting an Invitation to Share Items .....	209
Working within a Shared Folder .....	210
Linking to Shared Items .....	211
<b>Appendix A: Standard Zimbra Web Client .....</b>	<b>213</b>
Overview .....	213
Features Available on the Standard ZWC .....	213
Navigating the Standard Zimbra Web Client .....	225
Move to... ..	226
More Action... ..	227
Navigation Functions Not Available .....	227





# 1 Getting Started with the Zimbra Web Client

---

The Zimbra Web Client (ZWC) is a full-featured messaging and collaboration application that offers reliable, high-performance email, address books, calendaring, task lists, and Web document authoring capabilities.

This chapter explains how to...

- Select the version of ZWC to use
- Log in and log out
- Navigate your account
- Use Zimbra Assistant
- Learn about the availability of shortcut keys



Some accounts will not include all the features mentioned in this guide. Check with your administrator to see which features are enabled for your account.

## Advanced and Standard ZWC

The ZWC has two versions:

**Advanced Web Client** offers the full set of Ajax-based Web collaboration features. The advanced Web client works with newer browsers and faster Internet connections.

**Standard Web Client** is a good option when Internet connections are slow or users prefer HTML-based messaging for navigating within their mailbox.

This user guide describes the advanced ZWC. Many of the same features are available for the standard ZWC but may not be accessed as described in this guide. The differences between the advanced and standard versions of the ZWC are summarized in Appendix A: Standard and Advanced ZWC. Refer to the Help in the ZWC for more information about these features.



## Features of the Zimbra Web Client (ZWC)

The features of the ZWC are summarized in the following table.

Function	Feature Name	Description
<b>Safety and Security Features</b>		
Spam Protection	SpamAssassin	Besides using predefined rules to control spam, the SpamAssassin filter learns what users consider spam and not spam from messages they specifically mark as <b>Junk</b> or <b>Not Junk</b> in their mailbox.
Extra email identities	Persona	The name and address configured for the account creates the primary account persona. Users can create up to 20 additional email identities (personas) to manage different roles.

Function	Feature Name	Description
<b>Capacity and Flexibility Features</b>		
Quickly see all related messages with the same subject	Conversation View	Users can see all their messages in a thread – inbox, sent, filed, and even trash – in one view.
Filter incoming Email	Email Filters	Users can set up different filters to sort and prioritize incoming email.
Manage the mailbox quota	Quota	Users can store email messages up to the quota set for their mailbox. They can see their quota usage from their mailbox main page.



<b>Function</b>	<b>Feature Name</b>	<b>Description</b>
Access messages coming in to other email accounts	POP3 access	With POP3 access, users can download their email messages from email programs such as Outlook Express, Outlook, Eudora, or Netscape Mail into the ZWC.
Send messages from more than one account	Choice of From addresses	Users can send all their email from one place but make it look like it's coming from different email addresses. This is useful if users are replying to messages sent to them at a different email address, via POP3 access.
Automatically forward Email	Set Forwarding address	Users can redirect their email to another email account. They choose whether or not to have the forwarded message saved to their ZWC account.
<b>Positive Member Experience Features</b>		
Keep dormant accounts	Accounts may remain dormant	Users are not required to sign in to keep their account active.



## Zimbra Web Client Components

The main ZWC components are Email, Address Book, Calendar, Tasks, and Documents. User Preferences and Zimbra Assistant are also powerful ZWC features.

The features of each component are included in the following table.

Component	Features
Email	<ul style="list-style-type: none"><li>• Compose and send new email messages</li><li>• Include attachments with your message</li><li>• Read and reply to email messages</li><li>• Forward email messages to one or more recipients</li><li>• Track email exchanges using the Conversation feature (to view an entire message thread at once) or traditional message view</li><li>• Search email messages, attachments, and other ZWC areas</li><li>• Create your own folders to organize email</li><li>• Create tags to organize your email, contacts, etc.</li><li>• Create filters to route incoming email to designated folders</li><li>• Configure your ZWC account to receive email from your POP3 accounts</li><li>• Share your email folders</li></ul>
Address Book	<ul style="list-style-type: none"><li>• Create and manage multiple address books</li><li>• Easily add contacts from email messages you receive</li><li>• Import and export contact lists</li><li>• Share your address books</li></ul>



Component	Features
Calendar	<ul style="list-style-type: none"><li>• Create and manage multiple calendars</li><li>• Create appointments, meetings, and events</li><li>• See attendee's free/busy schedules</li><li>• Import and export calendars</li><li>• Share your calendars</li></ul>
Tasks	<ul style="list-style-type: none"><li>• Create multiple tasks lists</li><li>• Create to-do tasks</li><li>• Add attachments to your tasks</li><li>• Manage a task, set the priority, and track the progress</li><li>• Share your task lists</li></ul>
Documents	<ul style="list-style-type: none"><li>• Create multiple notebooks to organize your Web documents</li><li>• Design pages using an HTML editor, create tables and spreadsheets, add graphics, and create links to Web pages</li><li>• Share your notebooks</li></ul>
Briefcase	<ul style="list-style-type: none"><li>• Upload any type of file to your briefcase so that you can access the file whenever you log on to ZWC</li><li>• Create folders to organize files that you upload</li><li>• Share your Briefcase folders</li></ul>



Component	Features
Preferences	<ul style="list-style-type: none"><li>• Manage how your mailbox features work for Email, Address Book, and Calendar</li><li>• Create email filters</li><li>• Set up forwarding to another email account</li><li>• Create notification messages, such as a vacation message, and designate when to turn them on and off</li><li>• Choose a different language to view a mailbox user interface</li><li>• Assign shortcut keys to quickly access email folders, saved searches, and tags</li><li>• Use different account identities (personas) and addresses to manage different roles in your job or personal life</li></ul>
Zimbra Assistant	<ul style="list-style-type: none"><li>• Use keyboard shortcuts to:</li><li>• Create new appointments</li><li>• Go to a specific date in your calendar</li><li>• Create new contacts</li><li>• Send a new email message without leaving the application you are using</li></ul>



## Browser Compatibility

The Zimbra Web Client is designed to work within an Internet browser. The recommended browser is Mozilla Firefox 2.0 or later. Not all browsers are supported, so check with your administrator if you have questions.

Follow these general guidelines when using the Zimbra Web Client within a browser:

- The browser's **Back** button takes you to the previous page you were viewing. You can also use the **Forward** button.
- Do not use the browser's **Reload** (Refresh) button. Doing so will restart your session.

## Logging In

Open a browser window and enter the URL provided by your administrator. In most cases, Advanced is the default client and is opened automatically when you log in. Before you enter your name and password, you can switch to the standard web client or to the mobile client.

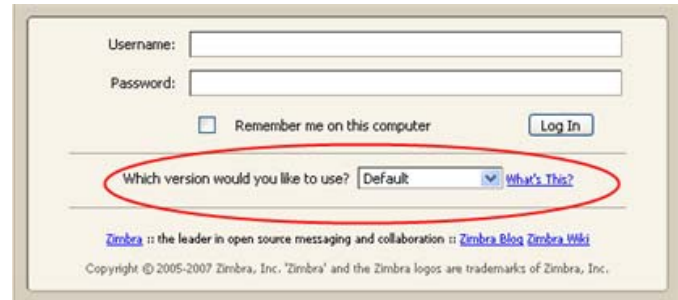

You can change the default from your Preferences General tab after you log in.

To change the default to standard after logging in:

1. Select the Preferences > General tab.
2. Select either **Advanced** or **Standard** in the **Login Options** section.

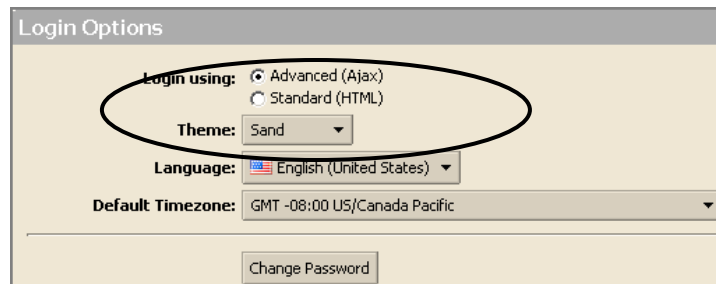

- 3.
4. Click **Save**.



The next time you log in, your selection will be the default.

### To log in

5. Open a browser window and enter the URL provided by your Zimbra administrator.

For example:

**http://mail.domain.com/zimbra/mail**

6. When the login screen appears, type your user name. You may be required to type your full email address as the user name and your password.

Example of a full email address, type:

myra@example.com  
myra123

Your password displays as \*\*\*\*\* on-screen, to protect your privacy.

To be remembered on this computer until the session expires or you log out, check Remember me on this computer.

If you check this, you will not have to log in every time you restart the browser during a day. When this is checked and you do not log out, your session remains active until the session expires. The system administrator configures how long a session is active.

Note: If you leave your web client open in your browser but do not access your mailbox for a period of time, your session may time out and then you will need to log back in.

If you do not want the default client type, change the version displayed.

7. Click **Log In**.

### To log out

To prevent others from logging in to your email account, you should always use the **Log Out** link to close your session.

### Forget your password?

If you forget your password, contact your administrator to reset it for you.

## If Your Session Expires

Your system may be configured with a session time-out that automatically logs you out if your session is inactive for a pre-configured period of time.

Your administrator may also set a maximum session length, e.g., a maximum amount of time that you can be logged in, regardless of whether any activity occurs or not.

Therefore, you may periodically see the login screen, even if you are already logged in. If that happens, simply log in again and continue working.

## Navigating the Zimbra Web Client

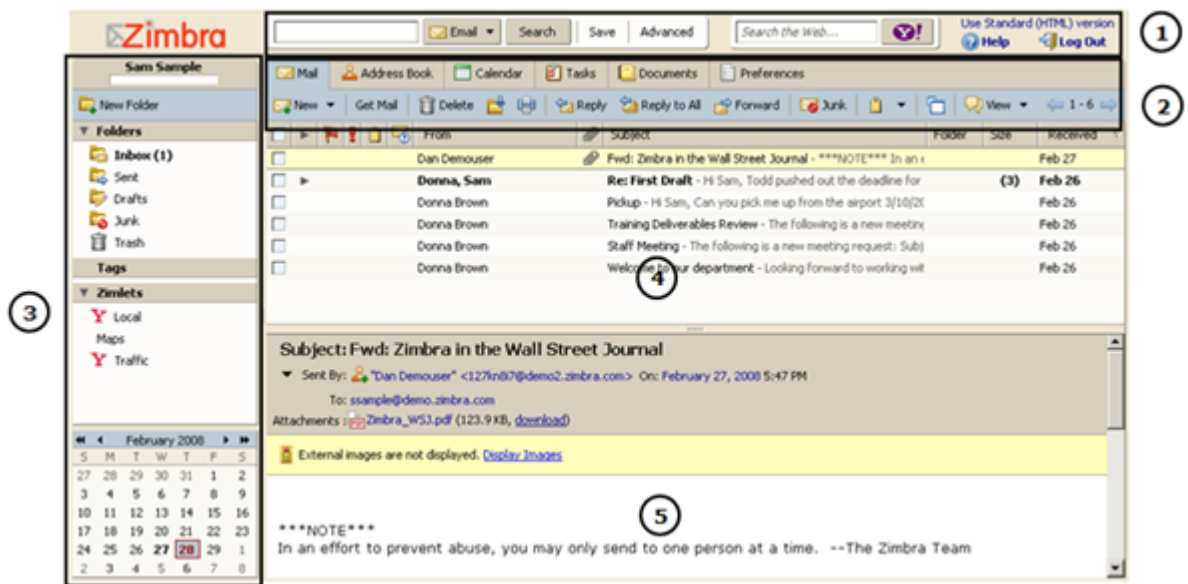

When you log in you see a full screen view similar to the one shown below. The view changes when you use another ZWC application. This view is the Mail view.



Refer to the following table when viewing the ZWC.

Number	Description
1	<p><b>Window Header.</b> Displays the following:</p> <p><b>Search Bar</b> - including the Save and Advanced buttons for ZWC searches</p>



Number	Description
	 <b>Help</b> and  <b>Log Out</b> are displayed on the right
2	<p><b>Toolbar.</b> Displays the following:</p> <p><b>Tools Tabs</b> – click a tab to access the different ZWC tools available for your account. In this example, Email is open.</p> <p><b>Action Buttons</b> – click an action button to perform a task available for the application you are currently using. In this example, the <b>Email</b> action buttons are displayed in the toolbar.</p>
3	<p><b>Overview Pane.</b> Displays the following:</p> <p><b>User Name</b> – the user name under which you logged in</p> <p><b>Quota Display</b> – your mailbox quota</p> <p><b>Folders</b> – including system folders (Inbox, Sent, Draft, Junk, Trash) and folders you created</p> <p><b>Searches</b> – search queries that you created and saved for future use</p> <p><b>Tags</b> – any tags you have created. Click on a tag to quickly see all messages that are tagged with that tag.</p> <p><b>Zimlet</b> – links that may have been created to integrate with third-party applications from within your mailbox. Depending on your configuration, you may not have access to Zimlets from the Overview Pane.</p> <p><b>Mini-Calendar</b> – optional. You can disable the mini-calendar using the <b>Preferences &gt; Calendar</b> tab.</p>
4	<p><b>Content Pane.</b> The content of this area changes depending on what application is in use. In the Inbox view, it displays all messages or conversations in your Inbox.</p>



Number	Description
5	<p><b>Reading Pane.</b> Email messages are displayed in the Reading Pane. In the email message shown here, you can see:</p> <p><b>Contact Zimlet:</b> Click a name in any email message to quickly add the name as a contact in an address book.</p> <p><b>Meeting Zimlet:</b> Click a meeting or appointment in any email message to quickly add the meeting to your calendar.</p>

## User Interface Features and Shortcuts

The Zimbra Web Client interface includes many convenient features.

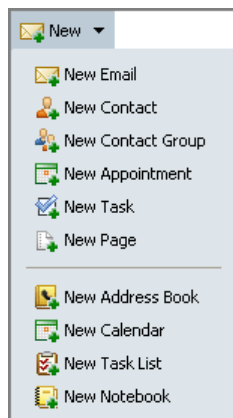

**Down-arrow menus.** Some buttons have a small down-arrow icon next to them.

- Click on the button to perform one action (such as open a new compose window).
- Click on the down-arrow icon to display a drop-down menu of additional choices, as shown here.

**Drag and drop.** Click on and drag messages, conversations, tasks, etc. between folders.

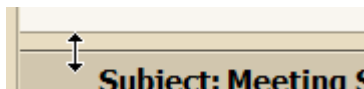

**Movable sash.** For split-pane windows such as the Conversation view, you can use the sash to increase or decrease the relative sizes of the upper and lower panes. Click and drag on the bar separating the panes.

**Clickable items.** Zimbra follows standard browser conventions by changing the mouse cursor to a hand when it passes over an active link.



**Tool-tips.** Passing your mouse cursor over items, such as command buttons, conversations, or email addresses in message headers, displays a small text box of descriptive information about the item.

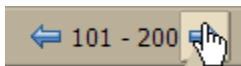

**Paging.** Use the left and right arrows in list windows to page back and forth if the list is too long to fit into a single window. Note that the paging buttons may behave differently on different screens. The numbers represent the sequence of items on that page. Use the Tool-tips display to identify what the paging will do on your current screen.

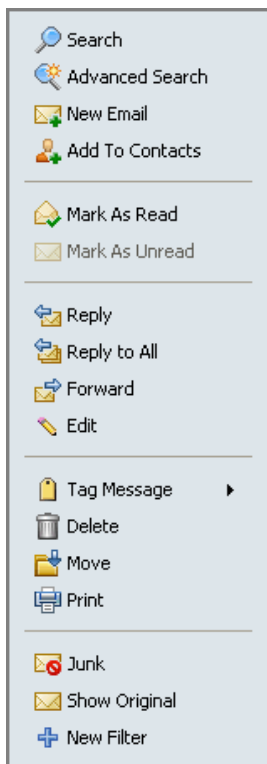

**Right-click menus.** Right-click on items (such as folders, conversations, messages, or items in email headers) to display a menu of functions that you can perform on that item. This is an example of the right-click menu on a user name in the Inbox From column.

The menu choices displayed depend on the type of item. Right clicking on the following displays right-click menus:

- **Conversations.** You can mark conversations as read or unread, apply tags to conversations, delete conversations, or move conversations between folders.
- **Messages.** You can reply to or forward messages, mark as read or unread, apply tags to a message, delete a message, move it to another folder, print, show original header information, and create a new filter.
- **Names in message headers.** You can perform searches on the name, begin composing a new Email message addressed to that person, or add the person to your personal Contacts list. If the name is an existing contact, you can edit the contact entry.

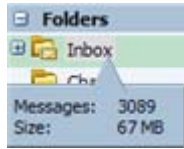

**Folder Information.** If you hover the cursor over a folder, the number messages in the folder and the size of the folder are displayed.

### Applying an Action to Multiple Selections

When you view a folder by clicking on the folder name in the Overview pane, the contents of the folder display with one item selected (highlighted). You can select one or more items to perform actions as follows:

- **Click** to select one item at a time. Click on another item to de-select the previous one.
- **Double-click** to open an item.
- **Right-click** an item to display a menu of actions that can be applied to this item. You can also right-click after selecting multiple items, to apply the same action to all of them at once.
- **Control-click** selects multiple items. Can also be used to de-select the current item, leaving nothing selected.
- **Shift-click** selects multiple items in sequence. Click on one item and then Shift-click another item further down the list. All items between the two selected items are highlighted.

You can select multiple items, and with one right-click, choose to **Mark as Unread**, **Tag**, **Delete**, or **Move all selected items**.

## Zimbra Assistant

Zimbra Assistant is an advanced user feature that provides a quick way to interact with the ZWC using the keyboard to do the following tasks:

- Create new appointments
- Go to a specific date in your calendar
- Create new contacts
- Send a new Email message without changing the application you are currently using

You can open Zimbra Assistant from any ZWC view except the Preferences tab.



The keyboard shortcut to open Zimbra Assistant is ` (back quote) or shift~ (tilde)  The tilde key can be found below the Escape (Esc) key.



Shift ~ (tilde) does not work when using Safari or Firefox from a Mac OS X. The back quote (`) does work.

### To use Zimbra Assistant:

1. Use a shortcut key (either the back quote or shift tilde) from within the ZWC to open the Zimbra Assistant dialog.

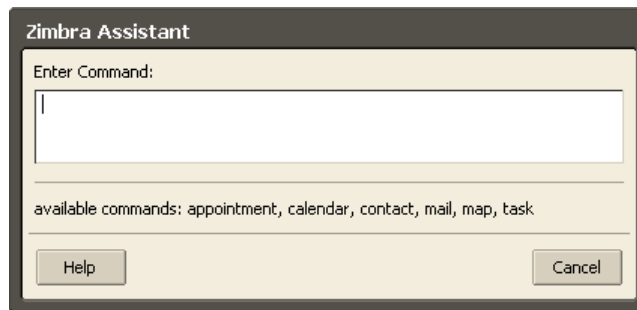

2. Click **Help** for detailed help on Zimbra Assistant.
3. Enter one of the following commands into the dialog:
  - o To create an appointment, type **appointment**. You can then enter a subject in quotes, the time, a date and day of week, and any notes for the appointment. Click **OK**.  
**Note:** If you want more advanced appointment features, click **More details** to go to the Calendar Appointment page.
  - o To go to a specific date in your calendar, type **calendar** and the date, or the day of the week. Click **OK**.  
**Note:** After the date you can enter the Calendar view you prefer: day, work week, week, or month. The Calendar opens in that view.





- 
- To create a new contact, type **contact** and enter the contact information. Click **OK**.

**Note:** If you want to open the Contacts detail form, click **More Details**. Use this form to specify which address book you want to add the contact name to.

- To send an email without opening a compose window, type **mail**. Enter the subject in quotes; type **to:name@address**; and then type the body of the message. Click **OK**.

## ZWC Keyboard Shortcut Keys

Shortcut keys can be used to navigate in the Zimbra Web Client (ZWC) and you can create your own shortcut key combinations. Use the **Preferences > Shortcuts** tab to see the list of shortcut keys and to create your own shortcut keys. The four **Shortcuts** tabs display the following:

- **Shortcut List** includes a list of shortcuts for all applications.
- **Email Folder Shortcuts** lets you create and assign shortcuts to access email folders.
- **Saved Search Shortcuts** lets you create and assign shortcuts to your saved searches.
- **Tag Shortcuts** lets you create and assign shortcuts to tags that you have created.



## 2 Receiving and Managing Email

This chapter explains how to...

- Customize your email page
- Navigate the email views
- Receive and read email messages
- Organize email messages

### Customizing Your Initial Email Page

By default, your mailbox opens with the Inbox view. In this view, all messages in your Inbox are displayed in the Content pane. You can change the initial view to be any of the folders, searches, or tags in the Overview pane. Change your initial view using the **Preferences > Mail** tab.

To display only specific messages when you open your mailbox, use the **Default Mail Search** field on the **Preferences > Mail** tab.

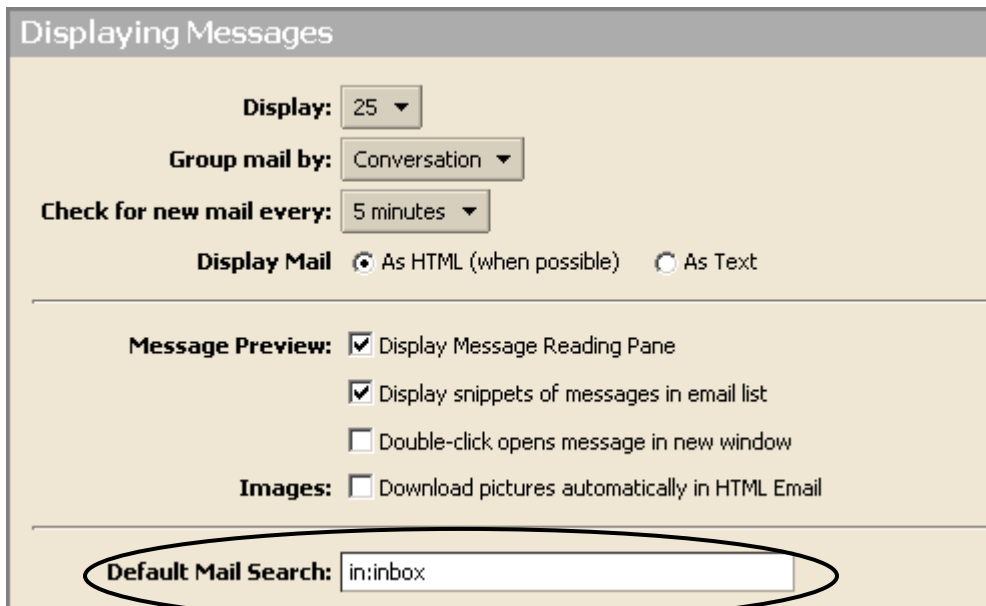

**Displaying Messages**

**Display:** 25 ▾

**Group mail by:** Conversation ▾

**Check for new mail every:** 5 minutes ▾

**Display Mail**  As HTML (when possible)  As Text

---

**Message Preview:**  Display Message Reading Pane  
 Display snippets of messages in email list  
 Double-click opens message in new window

**Images:**  Download pictures automatically in HTML Email

---

**Default Mail Search:** in:inbox



Here are some examples of how you can display only specific messages when you open your mailbox:

- To display only unread messages, type **is:unread** in the default mail **Search** field.
- To display messages that are tagged with specific tags, type **tag:<tagname>** in the default mail **Search** field. For example, to display only messages marked with the **ToDo** tag, type **tag:ToDo**. Tags are covered in Chapter 4.
- To display messages that you sent to a specific folder via an email filter, type **in:<foldername>** in the **Default Mail Search** field. For example, to display messages in the **Work** folder, type **in:work**. Filters are covered in Chapter 5.



Use quotes if the folder or tag is more than one word. For example **in:"Unread Email."**

## Email Views

If you receive a few email messages a day, you probably can quickly view the content of your mailbox to find the message you are looking for, but if you receive dozens of email messages a day, you may want to group them to more quickly find what you are looking for.

Your ZWC mailbox offers two options for viewing the messages in your mailbox.

**Message view.** Messages can be displayed in the Inbox by date. This is the traditional message view, where messages received today display the hour received, messages received in previous days show the date received.

<input type="checkbox"/>				From	Subject	Folder	Size	Received
<input type="checkbox"/>				Zimbra Team	Read Me First! Important Demo Account Information - Welcome to Zimbra C	Inbox	1 KB	Feb 08
<input type="checkbox"/>				Sam Sample	Re: Flight Plan - Hi Dan, I'll be arriving on UA 852 or ACA 4196 in the mornin	Inbox	4 KB	12/28/2007

**Conversation view.** The Conversation view displays your messages grouped by subject, as shown below. Because all messages in a conversation have the same subject, the subject displays only once in the conversation view pane. All messages related to the conversation are displayed, even if they are stored in different folders.



<input type="checkbox"/>					From		Subject	Folder	Size	Received
<input type="checkbox"/>					Yahoo ... Kevin		RE: Yahoo! Network Division All Hands - 2/19 & 2/21 - MAR		(3)	Feb 11
<input type="checkbox"/>					Jeremy Johnstone		Re: Cascade setup docs? - Nevermind. Found a more up to		(2)	Feb 09
<input type="checkbox"/>					<b>Sean, articles</b>		<b>Re: Reviewed articles - I will copy edit these three articl</b>		<b>(2)</b>	<b>9/5/2007</b>
<input type="checkbox"/>					<b>articles</b>		<b>I will copy edit these three articles and then a personal</b>		<b>2 KB</b>	<b>9/5/2007</b>
<input type="checkbox"/>					Sean Gallagher		I've reviewed the following articles and they're techn persone		2 KB	8/30/2007

## Parts of the Content Page View

Each message, in message or conversation view, has a separate line that displays the following columns of information.

<input type="checkbox"/>					From		Subject	Folder	Size	Received
--------------------------	--	--	--	--	------	--	---------	--------	------	----------

- **Check box.** Use the checkbox to select one or more messages to perform the same action on, such as delete, move, mark as read. Check the box in the header will automatically check all the messages on the page.
- **Conversation indicator.** Is this email part of a conversation? If is displayed, the message is part of a conversation.
- **Flag indicator.** Did you flag this message to indicate an action-needed item or to otherwise distinguish the message or conversation from a larger number of other items of lesser importance?
- **Priority indicator.** Did the sender mark this message as high priority?
- **Tags.** Did the message get marked by a Tag you defined?
- **Status.** Open or closed envelopes indicate whether a message has been read. Bold text also indicates that a message has not been read.
- **From.** Name or email address of the sender.
- **Attachment indicator.** A paper clip indicates that a message has an attachment.
- **Subject.** Brief description of the email message. If Snippets is enabled in your account, the first line of an email message is displayed.
- **Folder.** Shows the name of the folder where the message is located. For conversations, no folder name is displayed because messages can span multiple folders. When you open the conversation, this column displays where the message is located.



- **Size.** Size of the message or number of messages in the conversation.
- **Received.** Date or time the message was received.

## How Do Conversations Work?

The Conversation view displays your messages grouped by subject, as shown below. Because all messages in a conversation have the same subject, the subject displays only once in the conversation view pane. All messages related to the conversation are displayed, even if they are stored in different folders.

The number of messages in the conversation is displayed in parentheses in the Size column (after the subject). Each conversation consists of the original message and all replies. Conversations containing unread messages are shown in **bold**.

<input type="checkbox"/>		From	Subject	Folder	Size	Received
<input type="checkbox"/>	▼	<b>Donna, Sam</b>	<b>Re: First Draft - Hi Sam, Todd pushed out the deadline for</b>		<b>(3)</b>	<b>Feb 26</b>
<input type="checkbox"/>	✉	Donna Brown	Hi Sam, Todd pushed out the deadline for the	Inbox	2 KB	Feb 26
<input type="checkbox"/>	✉	Sam Sample	Donna, I plan to review the first draft that afternoon	Sent	868 B	Feb 26
<input type="checkbox"/>	✉	Donna Brown	Hi Sam, My first draft of the training materials will be	Inbox	1 KB	Feb 26

## Messages in a Conversation

You can read messages grouped together in context and ordered by date, including replies and forwarded messages. Messages grouped in a conversation have the same subject.

For example, the following subject lines would be considered part of the same conversation.

*Who's in charge of the project?*

***Re:** Who's in charge of the project?*

***Fwd:** Who's in charge of the project?*

If you change the subject to **who's in charge of the project? - ask Mike**, the message would not be included in this conversation.

Conversations do not continue indefinitely. If the last message in the conversation is 30 days old or older, messages sent with the same subject begin a new conversation.

## Conversations Can Span Folders

If a conversation includes three email messages, one of those messages could be in your **Inbox**, your reply (which is also part of the conversation) will most likely be in your **Sent** folder, and another message could be in a custom folder.

If you search for email messages and one message is found that matches your search, but that message is in a conversation with several other messages that do not match your search, the entire conversation and all messages within it are listed under the search results. When you open the conversation, only messages that match your search criteria are highlighted.

The same conversation may appear to exist in more than one folder. This can happen if the email messages are in different folders, either because you moved them there, or you applied a filtering rule that put them there when they were received.

Because a conversation is a group of related messages, if you move a conversation from one folder to another, all messages within that conversation are also moved to that folder. Sent messages, however, are not automatically moved. They remain in your Sent folder.

## Reading Email

To read an email message:

- Using Message view.
  - If you have the Reading pane on, click on a message to display its contents in the Reading pane.
  - If you do not have the Reading pane on, double-click on a message to display it in a separate window.
- **Using Conversation view.** Click the arrow in the conversation row containing the message.



The Content pane changes to show the individual messages in the conversation. The **Subject** column shows the first line of the message body.

- If you have the Reading pane on, click the line that contains the message you want to read. The message body appears in the Reading pane.



- If you do not have the Reading pane on, double-click the line that contains the message you want to read. The message body will fill the Content pane.

## The Reading Pane

The Reading pane is the area below the messages in your Inbox.

If you have the Reading pane on, when you click on an email message, the message displays in a pane below the message header information, and the message is marked as read. To adjust the size of the Reading pane, click and drag the divider bar up or down.

By default, viewing messages in the Reading pane is on.

To turn the Reading pane off:

- For this session only—Click the arrow next to **View** on the toolbar, and select **Reading Pane**.

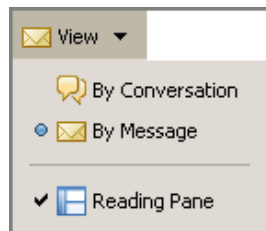

- For the default view—Use the **Preferences > Mail** tab. Uncheck Display Message Reading Pane.

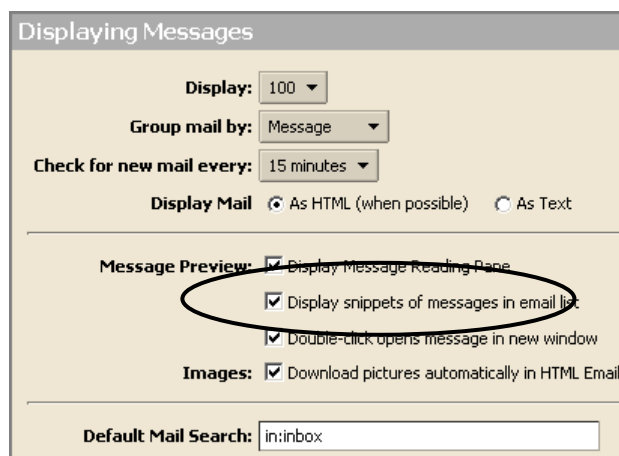





If you have the **Conversations** view feature, the default view is conversation.

To change views:

- For this session only - Click the arrow next to **View** on the toolbar, and select the view you want. The Reading pane option toggles the Reading pane on and off.
- For the default view – Use the **Preferences > Mail** tab.

## Displaying HTML in Email Messages

You can view email messages in two formats:

- **Plain text.** Plain text messages are messages that contain no HTML formatting code. Messages sent in plain text can always be read by other email clients. You can view messages in plain-text mode even if it contains HTML. The HTML tags are displayed in the body of the message in the plain text view.
- **HTML.** HTML messages can have text formatting, numbering, bullets, colored background, and links which can make messages easier to read. Some email clients may not accept messages formatted in HTML.

To always view your email messages in HTML:

1. Use the Preferences > Mail tab.
2. Check Display Mail As HTML (when possible).

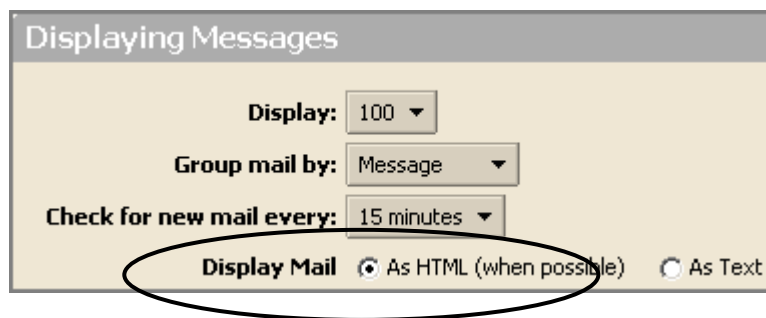

Messages will now be displayed in formatted layout, if they were sent in HTML.



## Parts of an Email message

An email message is shown below.

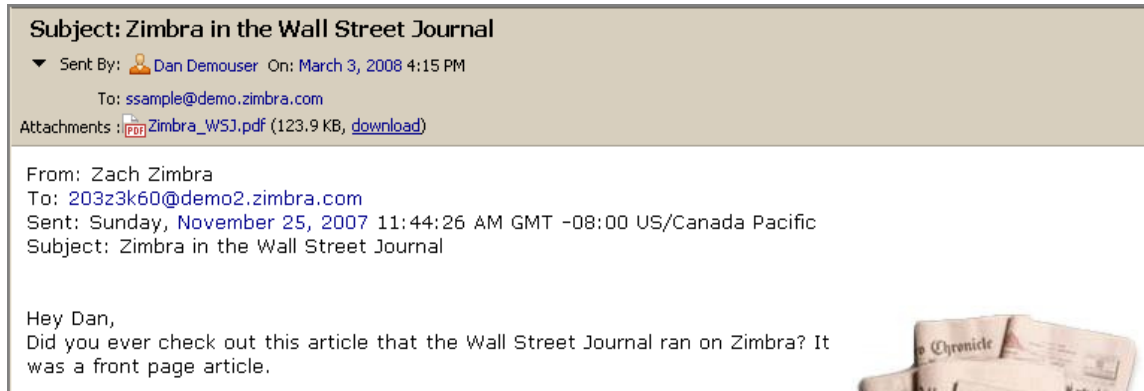

A ZWC email message has two main sections:

1. **Header.** The message header contains information concerning the sender and recipients, including the following information:
  - **Subject.** Description of the topic of the message. A subject line could be something like **2007 company mission statement** or, if your spam filtering application is too lenient, **Lose weight fast!!! Ask me how.**
  - **Sent By.** Sender's name and/or email address. This is the email address that becomes the recipient if you click  **Reply**. If the sender has specified a Reply-to address, your reply will be sent to that address instead.
  - **On.** Date and time the message was received.
  - **To.** Name and/or email address of the email recipient (where the message was actually sent).
  - **Attachments.** Any files that were included in the email message.

**Body.** The body of a message contains the content of the email. The message body also may include signatures or automatically generated text that is inserted by the sender's email system.

## Viewing an Attachment

Email messages can include attached files, such as the following:

- Word processing documents
- Spreadsheets
- Text files
- .zip files
- Images (.bmp, .jpg, etc.)
- Executable applications
- Any other type of computer file that resides on the sender's computer network

Messages containing an attachment have an  icon displayed next to the subject.

Some types of files, such as JPEG images or text files, can be opened on almost any computer system. Others, such as Microsoft Word documents, must be opened using the same application that created them.

To view an attachment, click on either the name of the attachment or the **download** link.

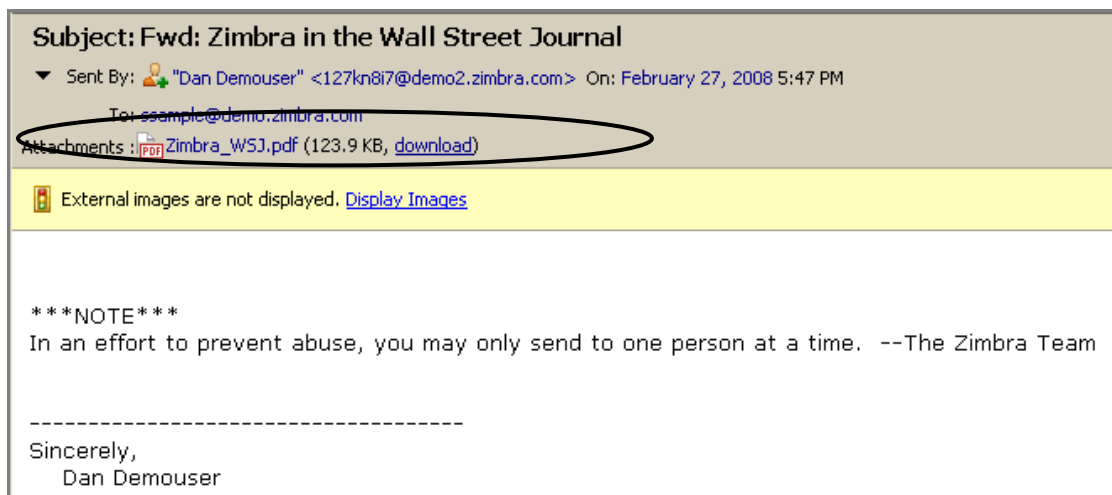

- Click the name of the attachment to open the attachment (if you have the correct application available).
- Click the **view as html** link (if it is displayed) to open the attachment even if the application is not installed on your network. This feature is set by your administrator.
- Click the **download** link to open a dialog prompting you to open or save the file.

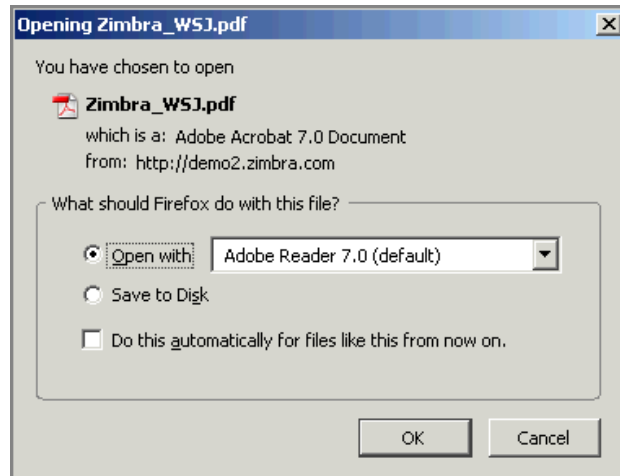

If you choose **Save to Disk**, a browse dialog appears showing your file system. Choose a location and save the file. You can then open the file outside of your email client.

## Marking an Email as Unread

The Zimbra Web Client (ZWC) marks messages that you open as read. Conversations containing unread messages are shown in bold.

To change a message's status back from read to unread:

- Right-click the message.
- Choose .

You can also mark a conversation as unread.

- Marking a conversation as unread marks all messages within that conversation as unread.
- Marking a single message as unread marks the conversation that contains the message as unread.



To change a message or conversation status back to read, do either of the following:

- Open the message or conversation.
- Right-click the message, and choose 



## Virus Safety

Computer viruses can spread through email attachments. It is standard practice for Email administrators to implement virus filtering for incoming Email as well as virus scanning for personal computers. However, there is always a chance that a virus could get through.

Many email viruses are activated when a file attachment containing the virus is opened or viewed. Many of these viruses have been known to spread themselves using entries in users' address books. Therefore, use care when opening file attachments, even from senders who you know.

## Printing an Email Message

To print an email message:

1. Click on the message you want to print.
2. Click  in the toolbar. A standard print dialog appears.
3. Choose a printer.
4. Click . The message is sent to the selected printer.



Do not use the browser's **File > Print** feature. The page will not be well-formatted, and your message may be difficult to read.

To print a conversation (all messages):

1. Right-click the conversation to be printed, and select **Print**. You must be in Conversation view.

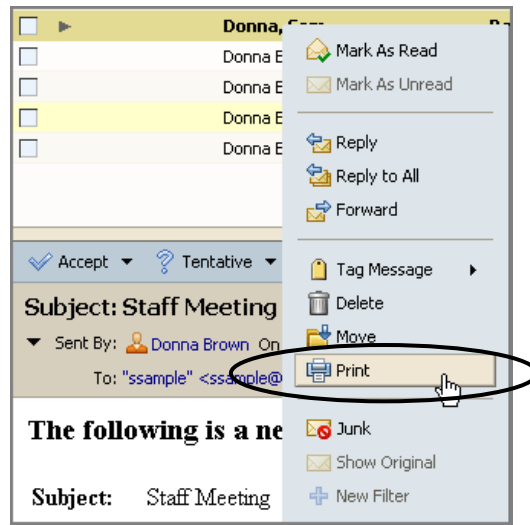

Two windows appear:

- One window, as shown below, shows all the messages in the conversation in a single scrolling window, and the total number of messages to be printed is displayed at the top.

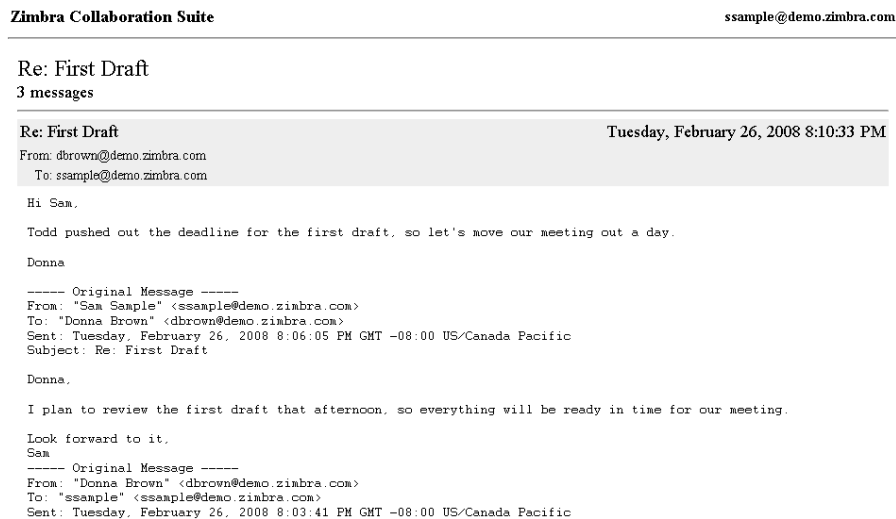

- A standard print dialog. In the print dialog:
  8. Choose a printer.
  9. Click **OK**. The message is sent to the selected printer.
  10. Close the window.

## Organizing Email Messages Using Folders

ZWC provides the following methods for organize email messages. You can use these along with the Search feature to quickly locate and retrieve messages.

- **Folders.** You can create folders to organize your messages, and you can move email between folders. Use of folders is covered in this chapter.
- **Filters.** In the **Preferences > Mail Filters** tab, you can create rules for classifying inbound email according to items in the subject line, sender, recipient, or other characteristics. Filters are covered in Chapter 5.
- **Tags.** You can use tags as labels on email messages and then use the Search feature to show all email with a certain tag. Tags are covered in Chapter 4.

## Mail System Folders Overview

The mail system folders are **Inbox**, **Sent**, **Drafts**, **Junk**, and **Trash**. You cannot move, rename, or delete these folders. System folders are always displayed at the top of your folder list, followed by any folders you create.

Refer to the following table for more information on the ZWC mail system folders.

Folder Name	Description
Inbox	New email arrives in the <b>Inbox</b> . Your Inbox is displayed by default after you log in.
Sent	A copy of each message you send is saved in the <b>Sent</b> folder.
Drafts	Messages you have composed but have not sent can be saved in the <b>Drafts</b> folder. Messages are automatically saved to the <b>Drafts</b> folder as you compose. If you navigate away from an unsent message, you will be asked if you want to save the message as a draft.



Folder Name	Description
Junk	<p>Most filtering of unsolicited automated email (also known as spam or junk mail) is handled by a spam filter before those email messages reach your <b>Inbox</b>. Email that might possibly be junk mail, but isn't certain to be junk, may be placed in your <b>Junk</b> folder.</p> <p>You can review these messages and either move them or delete them. If you don't delete them, they will be purged after a period of time, as specified by your administrator.</p>
Trash	<p>Deleted items are placed in the <b>Trash</b> folder and remain there until you manually empty the trash or until the folder is purged automatically. Email is purged from this folder after a specified period of time, as specified by your administrator.</p>



If your email account was migrated from another email system, such as Microsoft® Outlook®, you may see extra folders that represent folders from the previous email system.

## Sharing Your Mail Folders

You can share any of your mail folders, including the Inbox folder and sub-folders. You can share with internal users who can be given complete manager access to the folder or only the ability to view the folder.

When internal users share a mail folder, a copy of the shared folder is put in the Grantee's Folder list on the Overview pane. When the folder is selected, the content displays in the Content pane. You do not need to log on to the Grantor's mailbox.

### Scenarios for sharing a mail folder

- Your sales department wants one central mailbox for all email messages requesting information about your product, and everyone in sales should be able to view email messages immediately when they come in. You can give everyone in the department permission to view the mail folder and they can copy the messages to



their mailbox, or you can give them permission to manage the mail folder and they can reply on behalf of this address.

- A manager is often out of the office and does not have time to respond to her email messages. When the manager delegates access to her Inbox mail folder, her assistant (grantee) can manage the content of her mail, respond to messages on her behalf, create folders to organize message in that mail folder, and delete messages.
- Instead of sending email messages to dozens of addresses every time you have an announcement, you can identify one of your folders as a public folder that contains the email announcements. You can create shared access to only specific email addresses and set a password that must be entered to view the content, or you can make it a public URL for anyone who has the URL can view the content.

To learn how to share your mail folders, see Chapter 15, Sharing Your Account Items.

## Moving Email Messages

You can transfer email messages or entire conversations from one folder to another using one of two methods:

- Drag and drop the item to the desired folder in the left-hand Overview pane.



- Select the item(s), right-click, and select . The Move Message dialog appears.

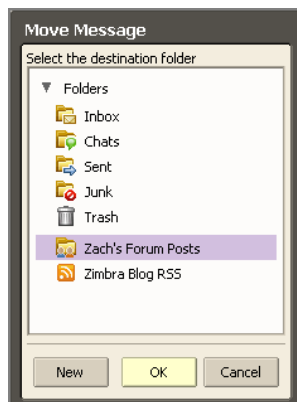

- Select a destination folder, and click **OK**.

If you are moving a few messages within a conversation, the conversation appears in both places. The Conversation Detail View window shows the new location of the message that was moved.

## Sorting Messages in the Content Pane

Any pane containing email messages, such as your Inbox, can be sorted by the **From**, **Subject**, and **Received** columns. Sortable columns are highlighted as you pass your mouse cursor over them.

To sort by a particular column, click the column title. The column shows an arrow indicating whether the sort is in ascending order (up arrow) or descending order (down arrow).

You can only sort by one column at a time.

## Deleting a Message: The Trash Folder

When you delete a message, it is moved to the Trash folder.

To recover a deleted message:

- Drag and drop the message from the Trash folder into another folder.

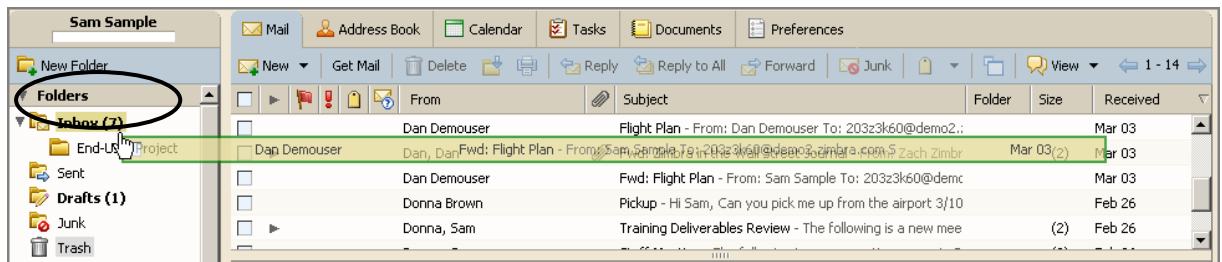

In the example above, the message from Dan Demouser is being dragged from the Trash folder into the Inbox folder (highlighted in Folder pane).

## Purging an Email Message from the Trash Folder

You can purge messages in Trash, which means the messages are permanently deleted and cannot be recovered.

To purge or delete messages from Trash:

- Right-click on the **Trash** folder and select **Empty Trash**. All messages are permanently deleted.

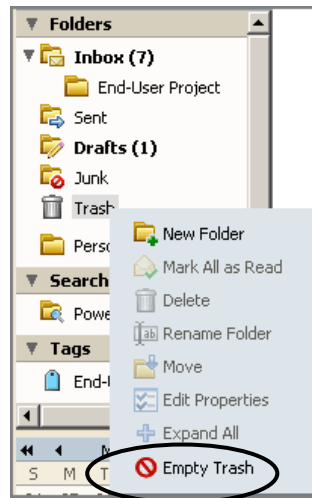

## Automatic Purge

Your administrator sets the policies for your site regarding how long messages remain in your folders before automatic purge occurs.

## Managing Junk Email & Spam: The Junk Folder

Most filtering of unsolicited automated email (also known as **spam** or **junk mail**) is handled by a spam filter before those email messages reach your Inbox.

Email that might possibly be junk mail, but is not certain to be junk, is placed in your **Junk** folder. You can review these messages and either move them out of the Junk folder or delete them. If you don't move or delete the messages, they are purged after a number of days as specified by your administrator.

## Spam

If you find that you are receiving a large number of unwanted email messages, often referred to as spam, contact your administrator. Reporting email as spam helps your email administrator to fine-tune any spam filtering that may be in use at your site.

## Marking an Email as Junk

### To mark an email as junk:

1. Select the message in your Inbox.
2. Click  on the toolbar.



The email is moved to your Junk folder.

Sometimes messages may be put in the Junk folder that are not really junk mail. Drag those messages to another folder.

**To empty the Junk folder:**

1. Right-clicking the Junk folder and select **Empty Junk**.

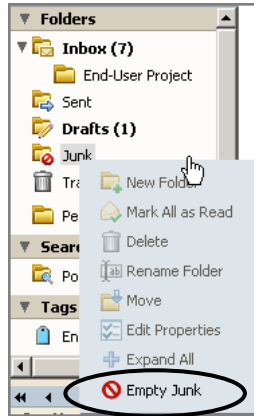

The contents of the Junk folder are automatically purged after an administration-configured number of days. Contact your administrator to find out how often your messages are purged.

## 3 Composing and Sending Email

---

This chapter explains how to...



- Compose a new email message
- Add attachments to messages
- Reply to email messages
- Forward email messages
- Configure optional email features
- Set up email signatures
- Set a forwarding address

### Composing a New Email Message

The ZWC uses standard email functionality with several enhancements. Using the ZWC, you can take advantage of the following features:

- Use automatic address completion to complete addresses for you (from your Address Book contacts) as you type into the **To**, **Cc**, and **Bcc** fields.
- Attach one of the many file types supported by the ZWC.
- Create custom signatures for use in your email messages.

**To compose a new email message, either:**

- Click  on the toolbar.
- Right-click on a sender (in the **From** column) in the Inbox, and select .

A blank compose page opens.

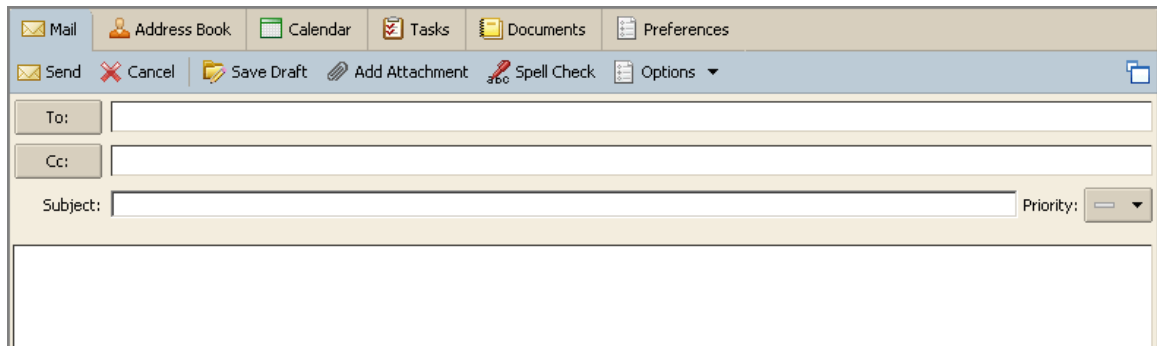

Depending on your email preferences, the blank compose page opens in the Zimbra content pane (as shown above) or opens as a separate compose window.

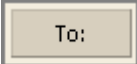

To complete the email:

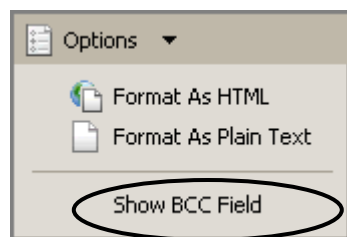
1. Enter the email address of the person or persons to whom you are sending the message in the **To** and **Cc** fields. Either type the address into the field, or click  to search through your contacts or the global address list.
2. Add **Bcc** addresses (if necessary) by clicking **Options > Show BCC Field** on the compose toolbar.

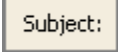



3. Enter the subject of the email in the  field.
4. Type the body of the email in the text area below the formatting icons.

From the compose toolbar:

5. Click  to check the spelling in the message.
6. Click  to add an attachment.
7. Click  to send the email.



8. Click  to save the message as a draft (to send later). The message is saved in the Drafts folder.
  - To retrieve a draft, open the Drafts folder and click on the message. You can compose and send the completed message as normal. When sent, the message is removed from the Drafts folder.
9. Click  to select a signature you have defined for use in this message.
  - Creating signatures is covered in the Optional Email Features section.



If you have more than one email identity (also known as a persona) configured, a **From** drop-down list will be displayed. Choose the identity to use for this message from the **From** drop-down list. More information on email identities and personas is provided in Chapter 6, Customizing Your Email Features.



If you supply a first and last name that is not in the form of a valid Internet address (name@domain.com), a confirmation dialog appears advising you that the address does not appear to be valid. You can choose to send the email anyway, even though it may not be deliverable.

## Cc and Bcc Addresses

The abbreviations **Cc** and **Bcc** stand for Carbon Copy and Blind Carbon Copy, respectively.

- **Cc.** Lets you send a copy of a message to someone who's interested but is not the primary recipient. All Cc'ed recipients see the entire list of addressees when they read the message.
- **Bcc.** Lets you send a copy of an email message to someone without their address appearing in the copies of the message sent to other recipients.

You can send a message without any addresses in the **To** field, as long as there is at least one address in either the **Cc** or **Bcc** fields.

## Using HTML Editor

You can compose your messages using HTML as the rich-text editor. Messages created using HTML can have text formatting, numbering, bullets, colored background, tables, and links which can make messages easier to read.

To quickly change the format for this message only:

- Click **Options > Format As HTML** to format your message with different font styles, tables, color, etc.
- Click **Options > Format As Plain Text** to produce text with no style or formatting.

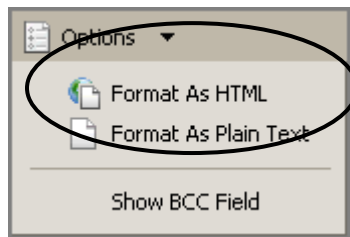

You can set the HTML editor as your default editor and set the default font settings (including style, size and color) using the **Composing Messages** area of the **Preferences > Composing** tab.



Some email clients may not accept messages formatted in HTML.



## Using Spell Check

To check the spelling of your message:

1. Click  on the toolbar. Words in the email message that are unknown to the spell checker are highlighted.

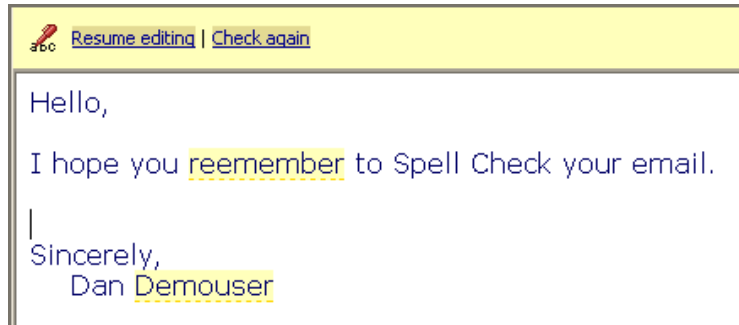

2. Right-click on a highlighted word. A drop-down menu displays suggested corrections.

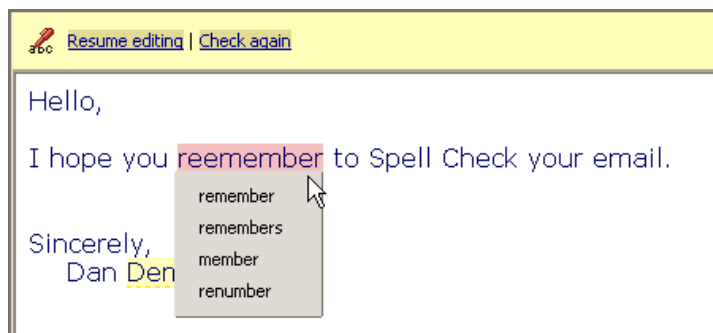

3. Select the correct word. The word is highlighted in another color.

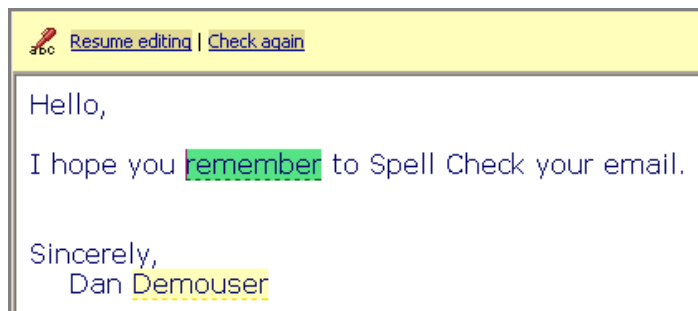

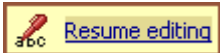

4. Click  at the top of the body to accept your changes and close the spell checker.



Before you close the spell checker you can change a corrected word back to the original spelling. Click on the highlighted word and select the initial spelling from the top of the pop-up.

## Adding an Attachment

Email messages can include attachments. You can attach documents, spreadsheets, pictures, slide shows, and other types of files.

To attach a file to a message:

1. Compose the email message.
2. Click . The **Attach File(s)** dialog appears.

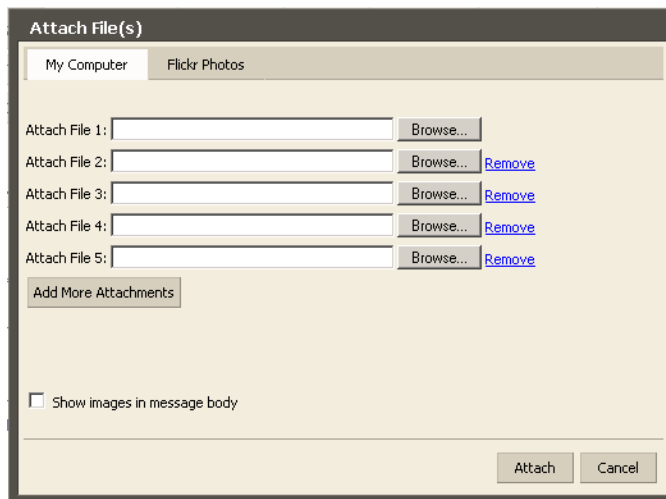

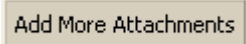
3. Click  to locate the file.
4. Select the file and click **Open**. The file name appears in the **Attach File 1** field.
5. Click  to attach another file.

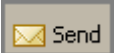

6. Repeat steps 3 and 4 for each attachment.
7. Click . The compose window appears with the attachment(s) in the header.
8. Click  to send the message and the attachment(s).



Recipients of your email message must have the appropriate software to open and read the file. For files created in commonly used packages such as Microsoft Office, other users on a typical desktop system will be able to open them. Common file formats, such as text files, HTML files, and images such as GIF or JPEG files, can be opened in a variety of programs.

## Attachment File Types Supported

You can attach any file on your file system that you can find using .

You can open any file attachment directly from the ZWC, provided that you have the right application and the extension is not blocked by your administrator. For example, to open a document created using Microsoft Word, you must have Microsoft Word on your computer.

On most computers, the file type is indicated by the extension, which is usually a period followed by a three-letter code. Examples could include files such as **expenses.xls** or **New-Items.doc**. If the file type is one that is supported by the installed software on your computer, you can typically double-click the file and your computer will automatically launch the right application for reading that file.

Many types of files can be opened directly from your browser using various plug-ins. Usually, if you click a file link on a page, your browser automatically detects whether or not you have the right plug-in and prompts you to download it. Note that your system administration policies may not permit end users to download and install any sort of software.

On Windows computers, the computer assumes that the file type in the filename matches the actual format. Even if the file is correctly formatted internally, if it does not have the right file type extension in the filename, your computer may not be able to recognize it and open the right application.

An increasing number of computer viruses have been designed to spread via file attachments. Therefore, in some environments, system administrators have opted to block incoming email containing certain types of attachments, most notably files with the extension .EXE or .ZIP as



part of their filename. If you send an email message to someone whose email system has been configured to block certain types of attachments, you may not receive any notification if the email was blocked.

For your reference, here are some widely used file extensions:

<b>File Extension</b>	<b>Description</b>
.txt	Indicates a text file, which is a file containing only text information.  Text files can be opened and read using a wide variety of text editors, including Notepad, WordPad, Word, command-line editors, browsers, and even spreadsheet programs.
.htm	Indicates an HTML file, a special type of text file that is usually opened using a Web browser.
.zip	Indicates a file that has been compressed using ZIP compression.  You will need WinZip or another compression program that can read and expand the ZIP file.
.exe	Indicates an executable or program file.  Double-clicking or opening such a file usually launches the application.
.doc	Indicates a Microsoft Word document file, which can be opened with Microsoft Word or OpenOffice.
.jpg	Indicates a graphical image in the JPEG format.  You can open JPEGs in a browser or by using one of a variety of graphics programs such as Paint or Adobe Photoshop.
.gif	Indicates a graphical image in the GIF format.  You can open GIFs in a browser or with a graphics program.



.mpg	Indicates a movie clip or animation in the MPEG format.  MPEGs are often playable with a browser plug-in or a player such as Windows Media Player.
.wmv	Indicates a movie clip in the WMV format, which is a Windows-only format.
.pdf	Indicates a document in PDF format.  You can typically open it from within your browser using an Adobe plug-in.

## Automatic Address Completion

The autocomplete feature suggests names as you type into the **To**, **Cc**, and **Bcc** fields in a new message. A list of possible addresses from your contacts list that *start* with the text you typed is displayed.

As you continue to type into the **To** field, the list of matching addresses becomes smaller as fewer matches are available. The list disappears if there are no matches.

The autocomplete feature matches the text you type against the following:

- First name
- Last name
- Email address

For example, you want to send an email message to David Brinks, whose email address is dbrinks@acme.com. When you type **D** into the **To** field, a list appears showing all possible matches, with the matching portions highlighted. In this case, it might display:

- Dale Edwards <ded@acme.com>
- David Brinks <dbrinks@acme.com>
- Erica Dodd <erica878@xyz.com>

As you type more characters into the **To** field, the list of matches grows smaller. To continue the previous example, when you type **Da** into the **To** field, the list would display:



- Dale Edwards <ded@acme.com>
- David Brinks <dbrinks@acme.com>

## Using Autocomplete

When your text matches one or more of your contacts, the matches are displayed in a list below the field you are currently editing. By default, the first match will be highlighted.

Several keys you can type trigger special behavior. The mouse may also be used to select a match.

- The comma, semicolon, Return/Enter, and Tab keys all trigger completion. The text you have typed will be replaced by the currently selected match.
- ESC hides the list.
- The up and down arrow keys change the selection in the list. Moving the mouse cursor over the list also changes the selection.
- Clicking the mouse on a match selects it for completion.

To use a single key to quickly enter an address:

9. Type a few characters that will cause a certain contact to be the first match. For example, type **s** to cause <Sam Sample> to be the first match.

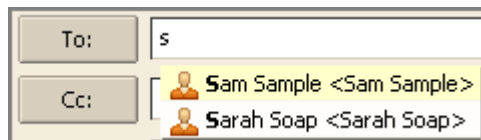

10. Press a quick key. For example, press Enter or the semicolon. The address appears.

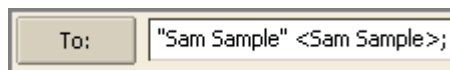

## Saving Your Work

The Zimbra Web Client is a graphical user interface (GUI) that includes windows, buttons, and text entry fields.

With a GUI that uses Internet browser technology to display and operate the user features, it is not always possible for the application to detect when you have done something that you might want to save.

Within the ZWC, the following rules apply:

- If you are in the middle of composing an email message, and you click another portion of the Zimbra screen, you are prompted to save your work. You can subsequently find the message in your **Drafts** folder.
- Emails you are composing are periodically saved to your **Drafts** folder by default. Your administrator sets the frequency of the auto-saves.

## Saving Messages You Send: The Sent Folder

By default, a copy of every email you send is saved in the **Sent** folder. You can delete email from the **Sent** folder at any time.

To change the default to not save a copy of messages you send:

1. Select the Preferences > Composing tab.

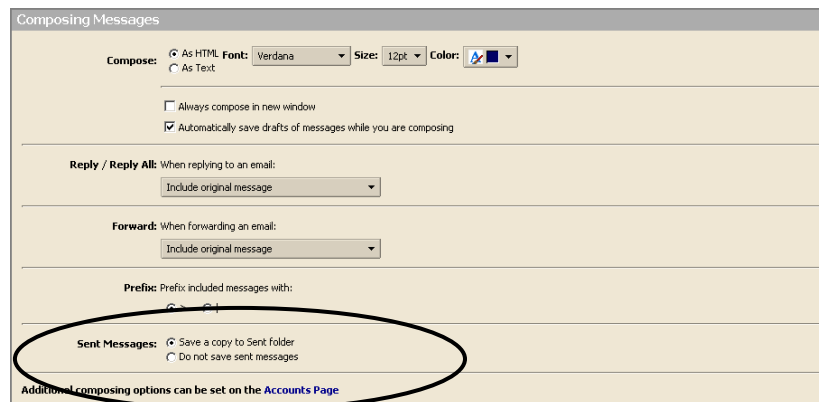



Select **Do not save sent messages** in the Sent Messages area.

2. Click .

## Replying to an Email Message

You can reply to the sender of a message or you can reply to the sender and all recipients of the message.

-  Click this button in the toolbar to open a new email compose window with the **To** field populated with the name of the person who sent you the original message.
-  Click this button in the toolbar to open a new email compose window with the **To**, **Cc**, and **Bcc** fields populated with the names of all recipients of the original message. Use this option if you want everyone who received the original message to receive your response.

Both options include the body of the original message in the reply. However, attachments from the original message are not included in the reply.

Depending on how you set your user preferences, the text from previous messages may have a character showing the number of previous exchanges that have occurred since this text was written.

For example if the reply is part of an ongoing conversation, and you have the option **Include original message with this prefix** set to use the > character, the text from each part of the exchange is shown with angle brackets:

> Previous message

>> Message before previous message

>>> And so forth





If the message is in a conversation, changing the **Subject** line will cause your reply to appear in a new conversation.



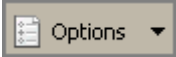
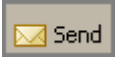

### To reply to a message:

1. Select the email you want to reply to.
2. Click  or  in the control bar. A new compose window is displayed with the address(es) in the header and the original message in the body.
3. Type your reply.
4. Click  on the toolbar if you want to change how the original message is included in the reply. The options include:
  - Don't Include Original Message
  - Include Original As Attachment
  - Include Original
  - Include Original With Prefix
  - Include Last Message Only
  - Your default option is marked but you can change it for this email only.
5. Click .



If you add your signature automatically to your messages, your signature is automatically placed in the message according to the preference you enabled: either at the end of all messages in the compose window or at the end of the message you compose, above the quoted text.



## Forwarding an Email Message

You can **Forward** an email message to someone else. Forwarding a message includes all file attachments, whereas **Reply** preserves the body text but does not include the attachments.

### To forward a message:

1. Select the email you want to forward.



2. Click  on the toolbar. A compose window opens. The text of the forwarded message appears in the body unless you have chosen to forward messages as attachments using the **Preferences > Mail** tab.
3. Enter addressees in the **To**, **Cc**, or **Bcc** fields.
4. Add a few lines of new text at the top of the message to let the recipient know why you decided to forward the message.
5. Click .

## Optional Email Features

There are several optional email features available when using the ZWC. For example, you can:

- Create an email signature
- Forward your Zimbra email to another email address
- Customize your initial email page

### Email Signatures

An email signature is closing text included at the end of an email. A signature can include your name and any additional text or graphics allowed by your email account. Contact your system administrator if you have questions about what is allowed by your email account.

For example, a signature could read:

**John Smith**  
Vice President of Engineering  
Widgets Division  
Acme Corporation, Inc.  
303-555-1212 x111  
john.smith@example.com

If you create multiple email identities (also known as personas), you can create different signatures and assign them to specific addresses. More information on email identities and personas is provided in the Managing Email chapter.

### To create a signature:

1. Use the Preferences > Signatures tab.
2. Type an identifiable name in the **Signature Name** field. You can create multiple signatures, so using an identifiable name here is important.



3. Type the signature text exactly as you want it to appear in the text box.
4. Specify where you want your signature displayed in the **Using Signatures** section.
  - o Select **Above included messages** to add your signature at the end of the your composed, replied to, or forwarded text.
  - o Select **Below included messages** to add your signature at the end of the message.
5. Click Add Signature.

### To apply this signature as the default signature for your account name:

1. Use the Preferences > Accounts tab.

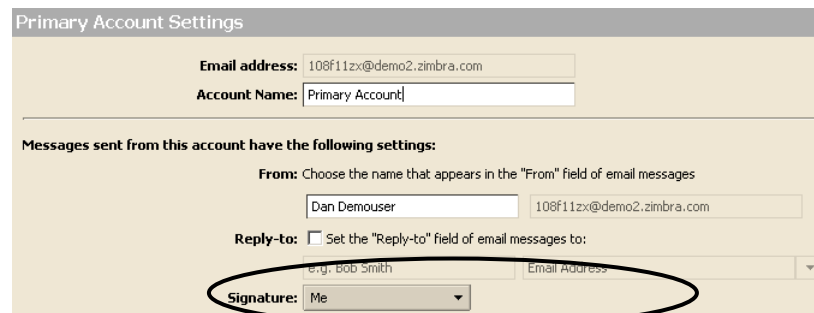

2. Select the signature name from the **Signature** drop down menu at the bottom of the screen.



## Undeliverable Email

Sometimes a message bounces, meaning it cannot be delivered for a reason such as:

- Recipient is not a valid or existing email address. Verify that you have the correct email address.
- Recipient's email system rejects the email for one reason or another.
- Recipient's mailbox is full.

If a message is rejected, you will receive an undeliverable mail message that includes:

- At least part of the contents of your original message
- Some system-generated error messages that provide more information as to why the email has bounced.

Try to correct the problem and re-send the email.

If the email bounces due to a bad email address, but you are certain that the address is valid:

- Contact the recipients using other means.
- Have the recipients resolve the issue with their system administrators.

Contact your administrator if:

- Every email message you try to send is rejected.
- Email bounces with **user unknown** or **bad address** messages for addresses that you used from your corporate address list.
- You start receiving bounce messages for email you did not send.

## Setting a Forwarding Address

You can identify an email address to forward your messages to and choose to retain the message in your mailbox or automatically delete the message when forwarded.

### To forward your email:

1. Use the **Preferences > Mail** tab. Scroll down to the **Receiving Messages** section.



Receiving Messages

**When a message arrives:** Forward a copy to:

Don't keep a local copy of messages

Send a notification message to:

Send auto-reply message:

**Messages from me:** When I receive a message originally sent by me

Place in Inbox  Place in Inbox if I'm in To: or Cc:  Ignore message

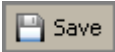
2. Type a complete forwarding address in the **When a message arrives: Forward a copy to** field.
3. If you want to automatically delete the email from your account, enable **Don't keep a local copy of messages**.
4. Click .





## 4 Using Tags and Folders to Organize Your Mailbox

This chapter explains how to...

- Create and use tags
- Flag email messages
- Use folders
- Create custom folders

### Working with Tags

Tags are your personal classification system for email messages, contacts, tasks, and appointments. Using tags is an aid for finding items. For example, you might have one tag for *Immediate Turnaround* and another for *Medium Priority*.

Some of the advantages of tags include:

- You can sort email using tags.
- You can search for a tag and all messages with that tag will be displayed, no matter what folder they are in.
- You can create as many tags as you want.
- You can apply multiple tags to the same email message and contacts.

### Creating Tags

You can create a **New Tag** using any of the following:

1. Right-click **Tags** in the Overview pane, and select **New Tag**.

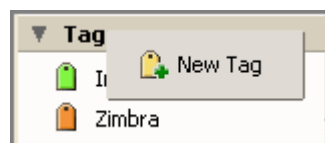

2. Select a message, click  in the toolbar, and select **New Tag**.

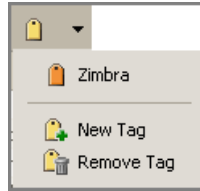

3. Right-click an item in a list view, choose **Tag Message**, and select **New Tag**.

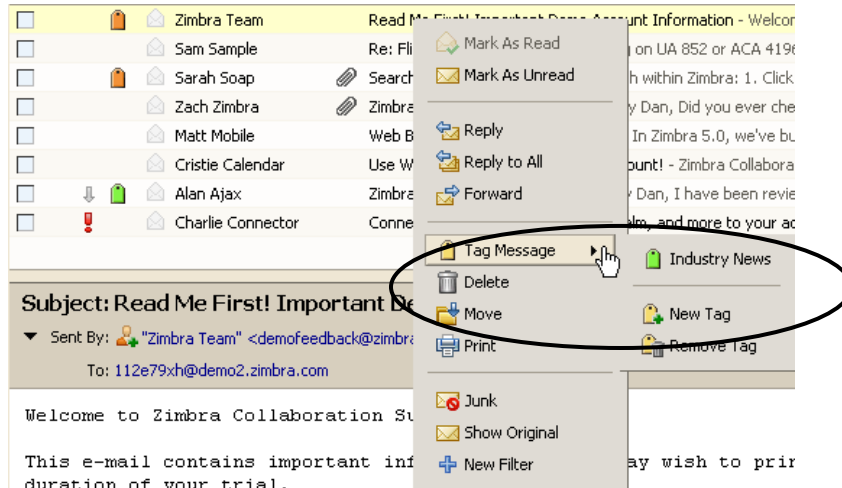

4. Right-click on **Tags** or a tag in the Overview pane and choose **New Tag**.

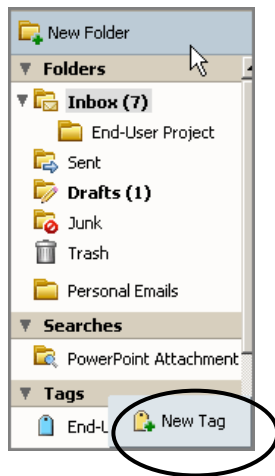

**To create a new tag using any of the previously mentioned methods:**

1. Select **New Tag**. The Create New Tag dialog is displayed.



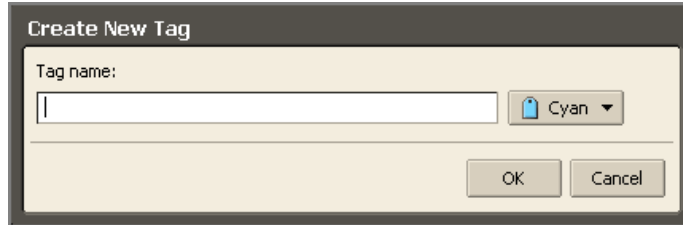

2. Type a name for the tag in the **Tag name** field, and choose a tag color from the drop-down menu.

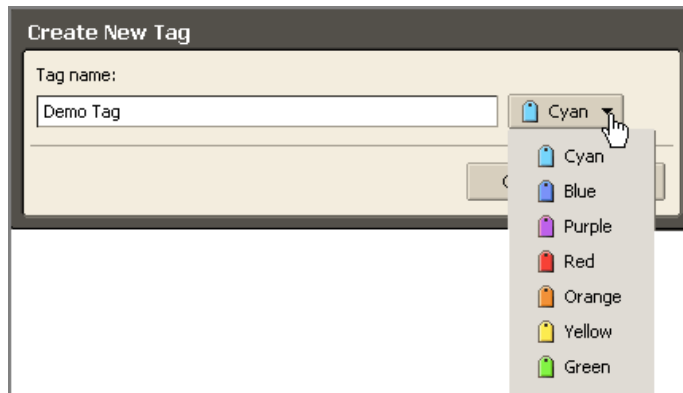

3. Click .

Tag names can have any character except the following

- : (colon)
- / (forward slash)
- " (double quotes)

The new tag is listed under **Tags** in the Overview pane and can be applied to any email messages or contacts.



You can assign multiple tags to a message. If a message has multiple tags, they are layered and multi-colored.

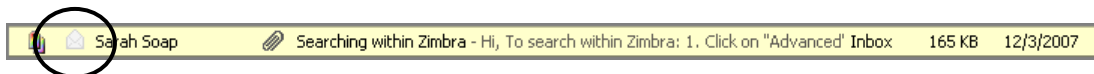

## Assigning a Tag to Messages and Other Items

Tagging is similar to flagging, except that you can create and apply multiple tags to a single item to classify it under several categories simultaneously. After you create a tag, you can apply it to conversations, messages, or contacts.

### To tag an item using drag and drop:

Drag and drop the tag from the left-hand Overview pane onto the item on the Content pane.

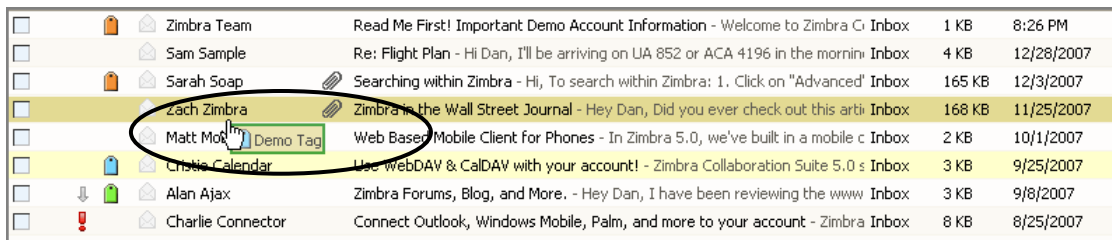

### To apply a tag to an item using menus:

1. Right-click the item from the Content pane.
2. Choose Tag Message (or Tag Conversation, Tag Contact, etc.).

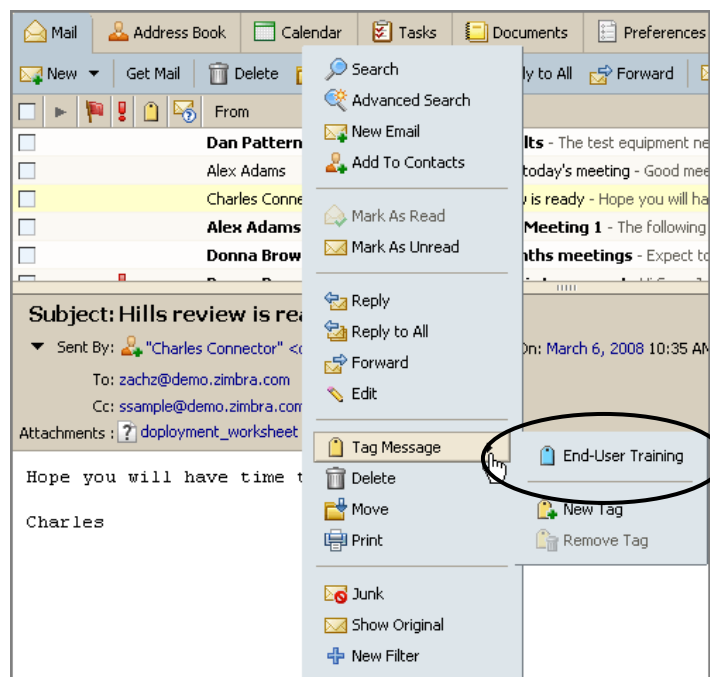



- Choose the tag name from the list that appears. Only tags not already applied to the selected item are listed.

### To remove a tag from an item:

- Right-click the item from the list and choose **Remove Tag**.

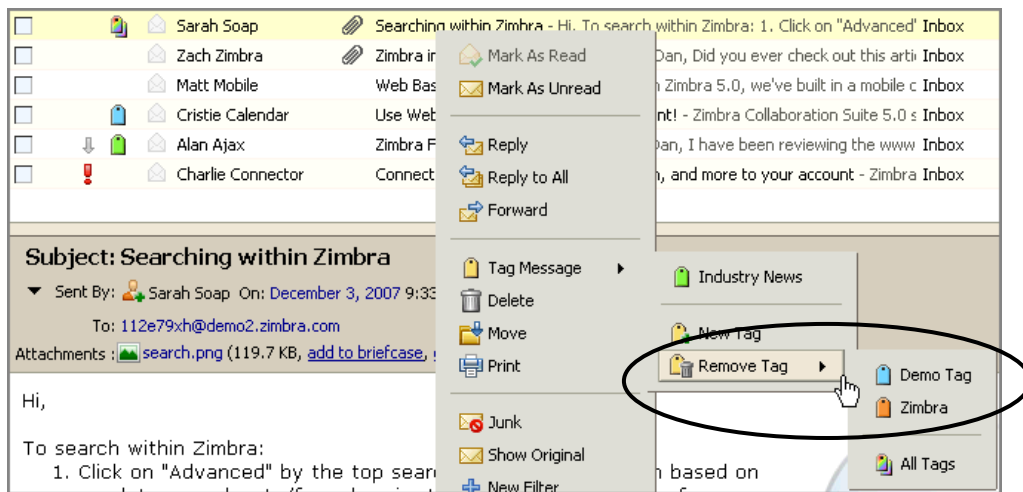

- Select the tag you want to remove, or choose **All Tags** to remove all tags at once.

### To apply/remove a tag to multiple items at once:

- Select all the items to be tagged using **Control-Click** or **Shift-Click**.
- Right-click over any one of the selected items, and choose an existing tag, **New Tag**, or **Remove Tag**.

To find tagged messages quickly:

- Click a tag in the Overview pane.



All messages with the selected tag are displayed in the Overview pane. In the example below, all messages with the **Demo** tag are displayed.

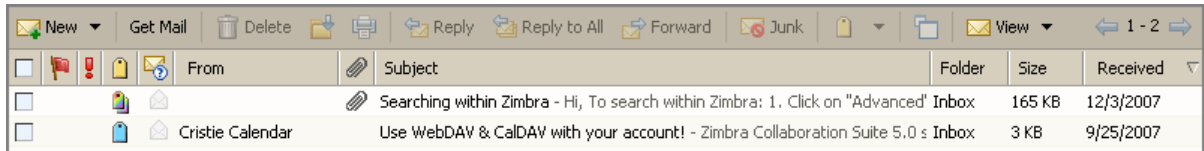

To search for tags, type one of the following into the **Search** field:

- **tag: <"tag name">**. Displays all tags with this name.



- **tag: "color"**. Displays all tags with this color.



## Deleting a Tag

To delete a tag:

3. Right-click the tag name on the Overview pane.
4. Click **Delete**.

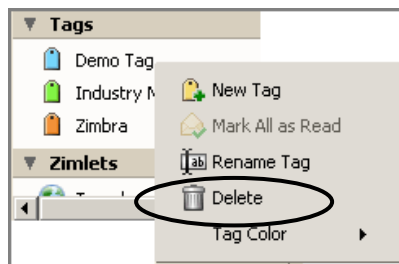

Deleting a tag removes the tag from any item that had that tag. The items themselves are not deleted.

## Flagging an Email Message

The flag icon in the message list is a yes/no indicator that denotes whether the email message has been flagged. This can be used to indicate an action-needed item or to distinguish the message or conversation from other items of lesser importance.

### To turn the flag on:

1. Place your cursor over the flag column for the message or conversation. The flag icon appears in a shadowed form.

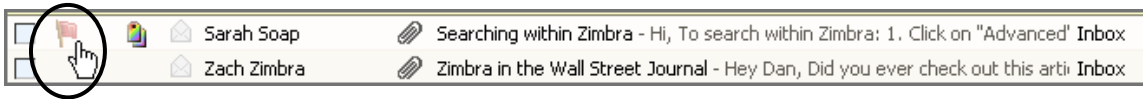

2. Click once directly over the flag icon. The flag icon appears in its active form.

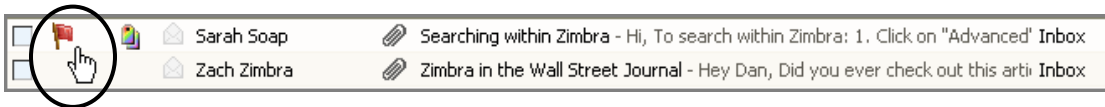

### To turn the flag off:

- Click on an active flag.

## Using Folders: General Techniques

There are two types of folders in the ZWC:

- **System folders.** System folders cannot be moved, renamed, or deleted. Examples include the Inbox, Sent, and Trash folders.
- **User-defined folders.** You can create folders to organize your email. Folders you create are displayed in the Folders list in the Overview pane. Top level folder names must be unique. The name cannot be the same as any other top-level folder in your email, calendar, or address book folders.

## Creating a Custom Folder

You can create custom folders. Custom folders can be created inside other folders, including system folders.

You cannot create two folders with the same name within the same parent folder. For example, you cannot have two folders named **Shopping** inside your Inbox folder, but you could have one folder named **Shopping** inside your Inbox folder, and another one with the same name inside the Sent folder.

### To create a new folder, either:

1. Click  at the top of the Overview pane, or

Right-click in the Overview pane in the folders list, and select **New Folder**.

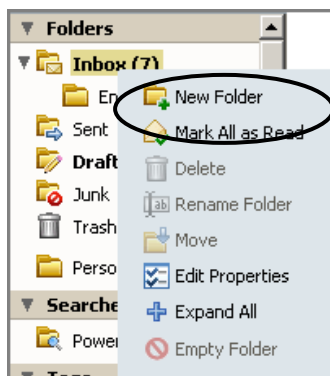

A **Create New Folder** dialog appears.

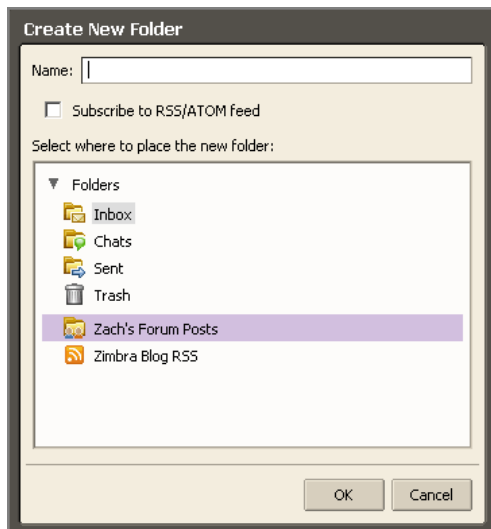



2. Type the folder name into the **Name** field.  
Select where to place the new folder. Either:
  - Click **Folders** to have the new folder displayed at the top of the list.
  - Click an existing folder to place your new folder within that folder.
3. Click .

## Renaming a Folder

To rename a user-defined folder:

1. Right-click on the folder, and choose **Rename Folder**.

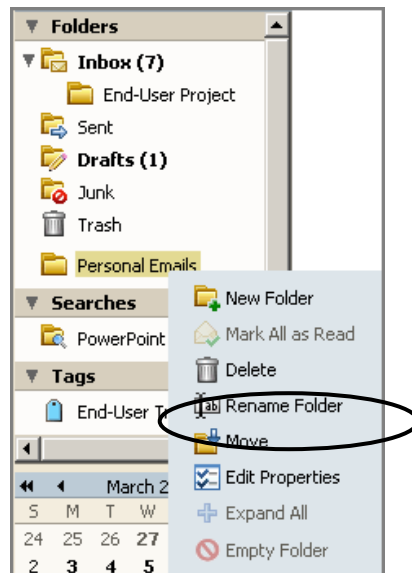

A **Rename Folder** dialog appears.

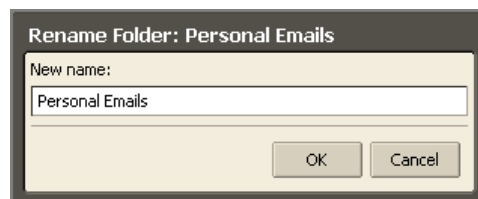

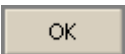
2. Type the new name for the folder into the **New name** field.
3. Click .



Folder names can have any character except:

- : (colon)
- / (forward slash)
- " (double quotes)

## Deleting a Folder

To delete a user-defined folder, either:

1. Drag the folder to the Trash.

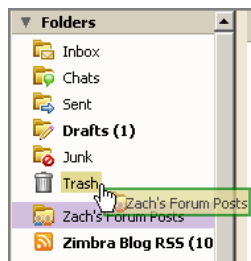

In this example, the **Zach's Forum Posts** folder is being dragged to the Trash.

2. Right-click the folder, and choose **Delete**.

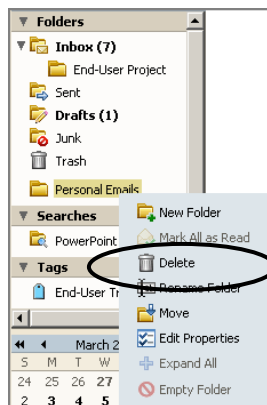

When you delete a folder, its contents are moved to the Trash. You can recover contents from the Trash by dragging and dropping them to another folder.

If you want to save some of the messages in a folder before you delete the folder, move the messages to another folder.





The Trash folder is purged on a regular basis, which is set by your administrator, so items in the Trash do not stay there forever.





## 5 Create Filters to Automate Email Handling

---

This chapter explains how to...

- Create filters
- Understand the conditions and actions of a filter
- Use wildcards when creating filters

Email filtering allows you to define rules to manage incoming email. Filtering applies a set of rules to incoming email and then executes a specified action. You can filter your incoming email messages to:

- Sort them into folders
- Automatically tag them
- Forward them
- Discard them

For example, you could create rules as follows:

- All email from your supervisor goes into your **Management Directives** folder.
- All email from the **corporate-events** mailing list is tagged with the **Events** tag.
- All email from a specific address goes into the Trash folder.

### Filter Conditions & Actions

Each filter rule consists of one or more conditions and one or more actions.

#### Conditions

For example, if your supervisor sends you emails from more than one address, such as jane.smith@company.com or jane-smith23@yahoo.com, you could create one filter called **Supervisor** which has two conditions, one for each email address.



Conditions include:

- Specific addresses in the **From, To, Cc** addresses in the email header
- Email messages that are under or over a specific size. Size can be specified as B, KB, or MB
- Date is before or after a specified date
- The presence or absence of file attachments
- Specify that addresses that are or are not in your Address Book.
- Words or character strings in the subject or body of the email message

All the conditions allow you to specify **not** as a negative condition. For example, you can specify email that does not contain a particular word.

You can combine conditions to search for email with more complex characteristics.

## Actions

Each filter rule can specify one or more actions. Actions include:

- Leave the message in the Inbox (no action)
- Move the message to another specified folder
- Tag the message
- Mark the message as read or as flagged
- Discard the message. This action drops the email message silently, which means that the message does not reach your mailbox. It is not the same as the Delete action on your menu. Deleting an item moves it to the Trash folder.
- Forward the message to a specified email address



Check **Do not process additional filters** to prevent the application of any other filter rules to email messages that match this current rule. If it is not checked, subsequent filter rules are evaluated for the email message even if the current filter is a match. You probably don't want to have the same message match more than one filter rule and undergo multiple, perhaps contradictory actions.



## Using Any and All

Conditions within a filter rule can be grouped using **Any** or **All**. The use of these terms is similar to **And** versus **Or** type searches, with **Any** being **Or** and **All** being **And**.

- **Any**. A message that meets any one of the conditions is considered a match.
- **All**. Every condition specified in that filter rule must match in order for that message to match the filter.



## When Filters are Used

All filters currently defined are listed on the **Preferences > Mail Filter** tab. The **Active** check box allows you to turn filters on or off without having to delete the filter rules.

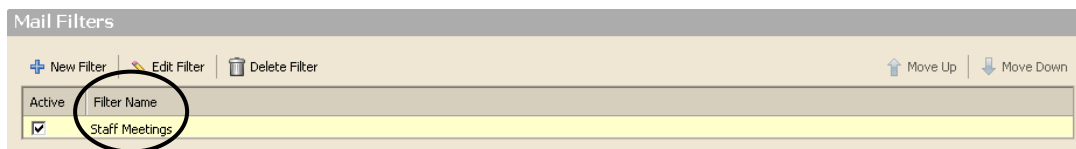
Each incoming message is tested against your active filter rules when it is delivered, and the filter actions are applied to matching messages at that time.



## Filter Order

Filters are applied in the order they are listed on the **Mail Filters** tab. You can change that order at any time using  and .

The conditions are used to test each email message. If the message meets the conditions collectively (using the **Any** or **All** designation as specified in the filter rule), it is a match. The order of the conditions within each filter is not important.

If the message matches the conditions, all actions associated with that filter rule are applied, in the order in which they appear in the filter.

## Creating a Filter

You can create a filter in two ways:

- Using the Preferences > Mail Filters tab
- Using a message in the Inbox

## Creating a Filter from the Mail Filters Tab

To create a new filter using the **Preferences > Mail Filters** tab:

1. Select the **Preferences > Mail Filters** tab.

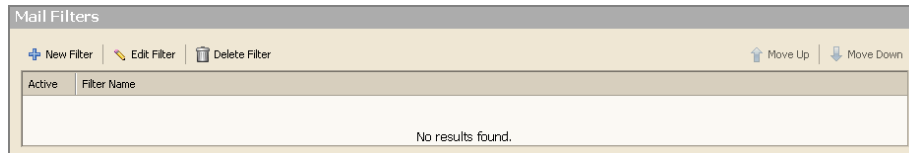

2. Click . The **Add Filter** dialog displays.

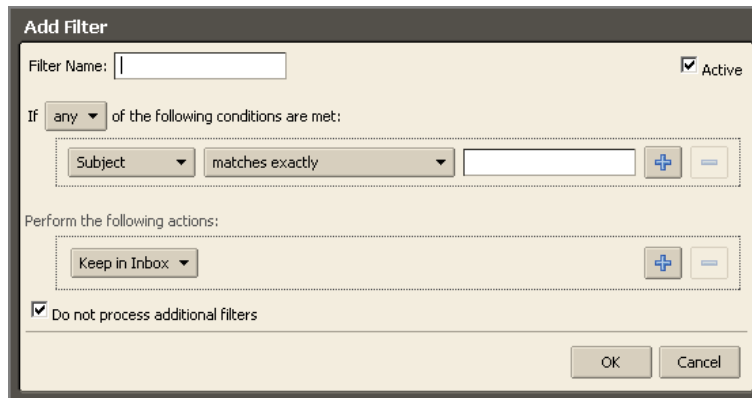

3. Type the name for the rule into the **Filter Name** field.
4. In the **If the following conditions are met** area, choose a grouping preference.



- **Any** means that if any of the conditions in the filter are met, apply the action.
- **All** means that all of the conditions in the filter must be met to apply the filter action.

Steps 5-11 can be repeated to set up multiple conditions and actions within a single filter:

5. Select from the first drop-down list which part of the email to filter. For example, choose an email field, a portion of an email message, or an email address.

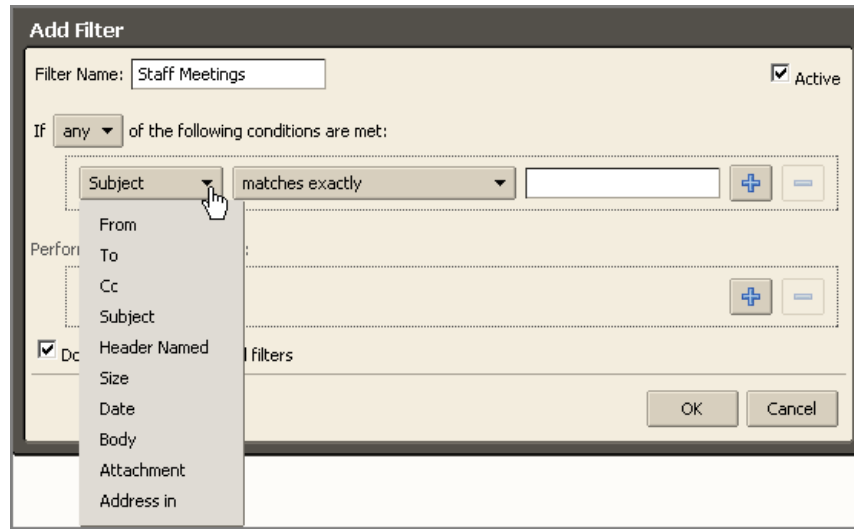

In the above example, **Subject** is selected. Therefore, the Subject of all incoming emails will be filtered.

6. Choose a comparison method. The options shown depend on your choice in the previous step.

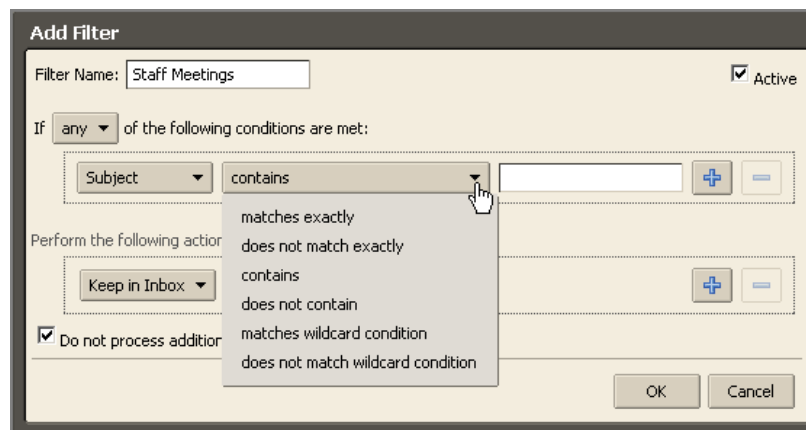

In the above example, **contains** is selected. Therefore, the filter will look for Subjects that contain certain text.

7. Enter a word or phrase to compare against in the text field. For example, enter **Staff Meeting** to filter all messages containing **Staff Meeting** in the Subject.
8. Click  to add more conditions, if needed. You can continue to add more conditions or proceed to add one or more actions.

9. Choose an action from the drop-down list in the **Perform the following actions** area.

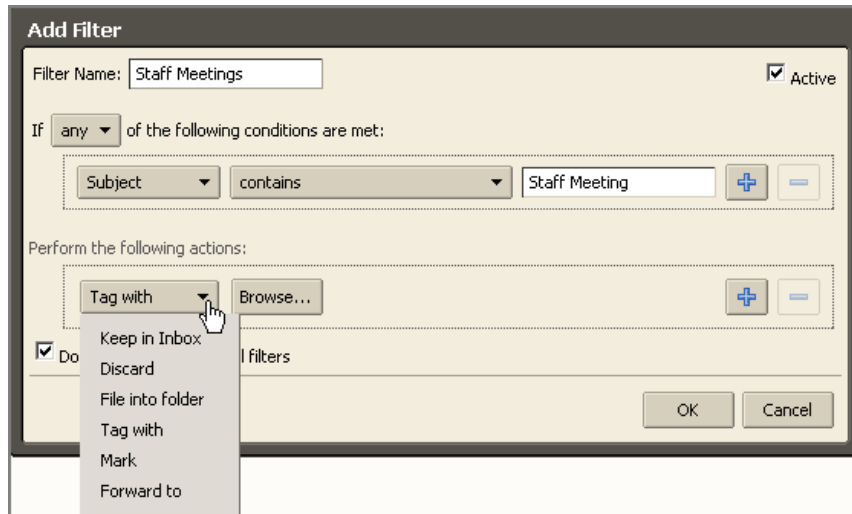

In the above example, **Tag with** is selected. Therefore, the filter will tag email messages with a Subject containing **Staff Meeting**.

10. Specify a folder or tag name, if necessary. What you specify depends on the action you chose in the previous step.

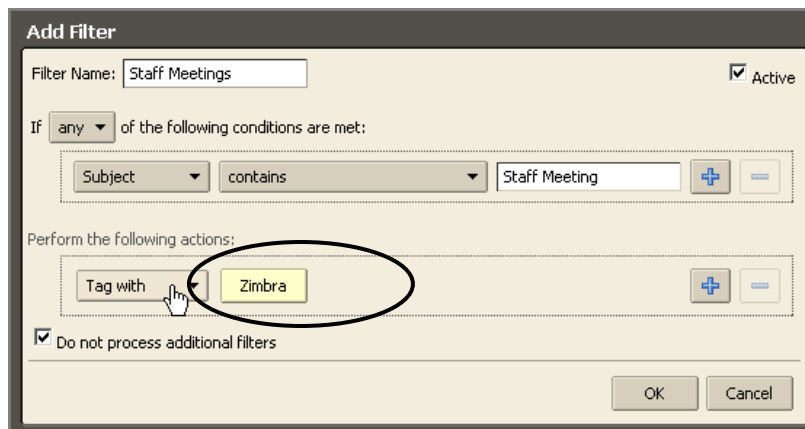

In the above example, the **Zimbra** tag is selected. Therefore, all incoming email messages that have a Subject containing **Staff Meeting** will be tagged with the Zimbra tag.

11. Check  **Active** (upper right corner of Add Filter box) to turn on the filter rule.
12. Click  to add more actions or click  to finish.





The filter will be applied automatically to all new incoming email messages as they arrive.

## Creating a Filter from an Email Message

To create a new filter from an email message:

13. Right-click on the message and choose **New Filter**.

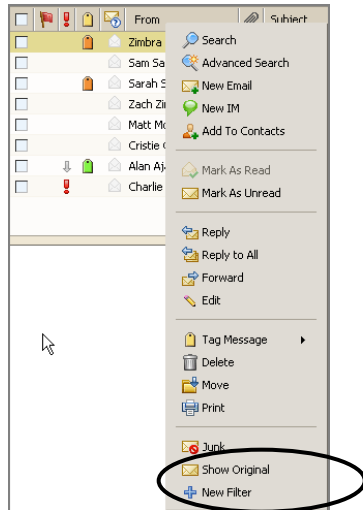

14. The **Edit Filter** dialog displays with **From**, **To**, and **Subject** set with this information from the email message.

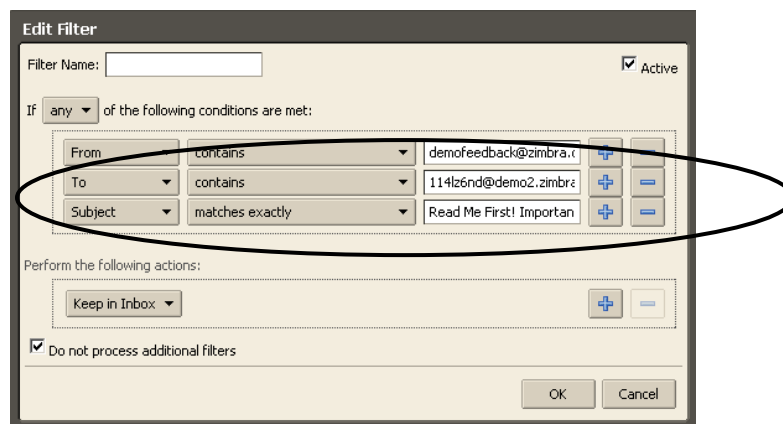

15. If the filter conditions are correct, enter a name in the **Filter Name** field and click

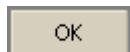

You can change the conditions and actions as necessary using the drop down menus in the Edit Filter dialog.

## Editing a Filter

To edit a filter:

1. Select the **Preferences > Mail Filters** tab.

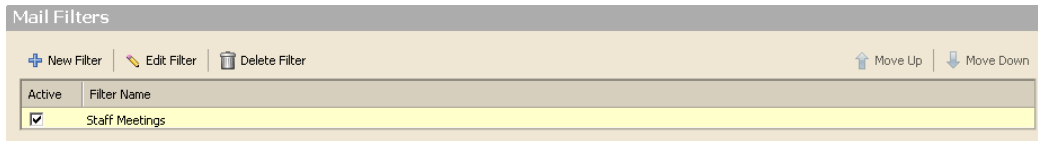

2. Click . The **Edit Filter** dialog displays.

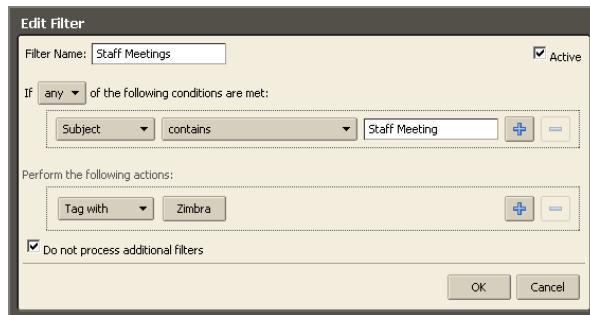

3. Use the drop-down menus and fields to edit the filter as necessary.
4. Click .

## Filter Conditions and Actions Supported

This section describes the conditions and actions supported by ZWC filters. Filter rules are not case-sensitive, so the rules ignore capitalization.

### Conditions

Comparison fields include those in the following table.

Comparison Field	Description
From	Use this to specify a <b>From</b> name in an email message.
To	Same as From, but looks for specified names in the <b>To</b> header.
CC	Same as From, but looks in the <b>Cc</b> header.



Comparison Field	Description
Subject	Looks in the message's <b>Subject</b> header.
Header Named	<p>When this option is selected, an additional text input field appears before the comparison operator (the <b>contains</b> portion). This option allows you to specify any email header. You can specify the standard fields of <b>To</b> or <b>From</b> and Date, Reply-To, or other custom fields that may be included in the message header.</p> <p>You could use this option to filter out email messages that have malformed headers, meaning they do not contain certain information that is normally considered standard for an email message. Sometimes spam, which is automatically generated, omits information such as the <b>Sender</b> or <b>Reply-To</b> fields. Use the second text field (the field immediately to the right of the comparison operator) to specify the header to test for.</p>
Size	Use this to select email messages that are larger or smaller than a specified size, including any file attachments. You can use this to discard email messages that are too large.
Date	Use this option to specify email messages sent before or after a specified date.
Body	The options for <b>Body</b> are Contains and Does not contain. This allows you to specify matching words in the body of the email. You cannot filter for words in file attachments.
Attachments	You can filter for email messages with or without attachments.
Address In	Tests for an address in your contacts and allows you to specify an address.



Comparison operators include those in the following table.

Comparison Operator	Description
Matches exactly/does not match exactly	Specifies an exact match.  For example, specifying Subject matches exactly Banana would only match Banana and not Bananas or A truck full of banana leaves.
Contains/does not contain	Specifies that the subject line must contain the specified substring.  For example, specifying Subject contains Banana would match I'm going bananas.
Matches wildcard condition/does not match wildcard condition	Specifies that the subject must match the specified string, which includes wildcards.  For example, specifying <b>bana*</b> would match <b>banana</b> and <b>banana tree</b> but not <b>free bananas</b> .  The wildcard * is a character used in the email filter comparison field to represent one or more characters in the filter.
Exists/does not exist	Matches if the specified field is present in the message. Used with the <b>Header Named</b> and <b>Attachment</b> fields.
Under/not under, over/not over	Used for comparison against the <b>Size</b> field.
Before/not before, after/not after	Used for comparison against the <b>Date</b> field.
In/not in	Used to test for presence of an address in your contacts.



## Actions

Available actions include those in the following table.

Action	Description
Keep in Inbox	Saves email to Inbox. If none of the filter rules match an email message, this action takes place by default.
File into Folder	Moves the email to a specified folder.
Discard	Deletes the email message without delivering it. The message is not in any of your folders, not even Trash.
Forward To	Forwards email to the address you specify.
Stop Evaluation	This action prevents subsequent filter rules from being applied to any message that matches the current one.
Mark	Select as <b>Read</b> or as <b>Flagged</b> .
Tag with	You can tag matching messages with a selected tag.



## Multiple Actions

A filter rule can specify multiple actions. The combinations of actions are interpreted as described in the following table.

Multiple Action	Description
Discard	If combined with other actions, discard is ignored and the other actions take place.
Stop Evaluation	Actions specified after this one are ignored.
File into folder	Multiple <b>file into</b> actions results in multiple copies of the message being stored in different folders. If a specified folder does not exist, the message is saved to the Inbox.
Tag/Mark	These actions apply to the message returned from the nearest preceding action. In the case of multiple <b>file into</b> actions, this could result in some copies of the message stored without a tag, and others stored with a tag.
Keep in Inbox	Multiple <b>keep</b> actions can be specified, but only one copy of the message is saved to the Inbox.

## Filter Wildcards

Wildcards can be used in comparisons that use the **Matches pattern** comparison operator. The two wildcard characters are \* and ?

### Asterisk (\*)

The asterisk is a placeholder for zero or more characters of any type.

Example	Match
Subject-line search string: <b>banana*float</b>	Subject lines such as bananafloat, bananas, banana-leaf casserole float but not super-banana-float



Subject-line search string: <b>w*bandanna</b>	Subject lines such as white bandanna or whose bandanna but not whose bandanna is this?
--	--

## Question Mark (?)

The question mark is a placeholder for exactly one character.

Example	Match
Subject-line search string: <b>banana?boat</b>	Subject lines such as bananasboat, banana-boat, banana!boat, or banana boat

## Escape Character is Slash: \

There may be times that you want to specify an exact match on a string that contains characters that normally are considered wildcards.

For example, you might want to specify a match on a subject line where the main heading is surrounded on both sides by three asterisks, such as:

- **\*\*\*MORE MONEY!!!\*\*\***
- **\*\*\*FREE GIFT\*\*\***

To specify a wildcard as itself rather than a substitution for other characters, use the backslash \ immediately before the character. For example the comparison string `\*\*\*\*\*` specifies a subject with three asterisks before and after any string in the middle (including spaces).

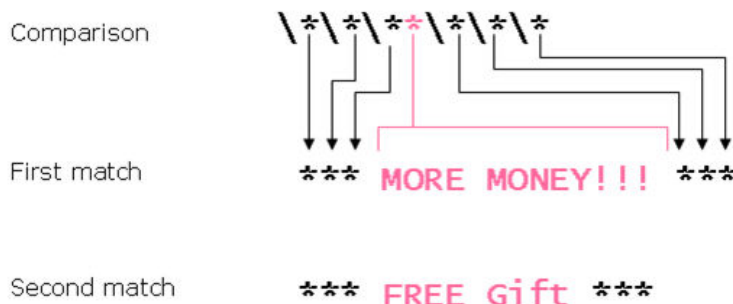





## 6 Customizing Your Email Features

---

This chapter explains how to...

- Set up new mail notification
- Create away messages
- Manage your account identities
- Change your default time zone

The ZWC offers several email features that you may choose to use when managing your mailbox. The advance email features include:

- **New Email Notifications.** Send email to another email message to notify you when you receive email in your Zimbra mailbox.
- **Away Messages.** Send out-of-office auto-reply messages when you are away.
- **Personas/Other Email Identities.** Create separate email identities, also called personas, to manage different types of email. For example, you can create a business persona for your business email and a personal persona for your personal email.
- **External Accounts.** Configure your Zimbra mailbox to check email at other, external email addresses.
- **RSS Feeds.** Create a folder to receive RSS (Really Simple Syndication) feeds directly into your Zimbra mailbox.
- **Mailbox Quotas.** Manage the size of your Zimbra mailbox, so you do not exceed your quota.

### Setting a New Email Notification

You can configure your email options to notify you at another email address when you receive email to your Zimbra mailbox. This feature may be useful if you do not receive a lot of email

to your Zimbra account, but when you do receive email, it's important enough to require a timely response.

**To set notification:**

1. Select the **Preferences > Mail** tab, and scroll to the **Receiving Messages** area.

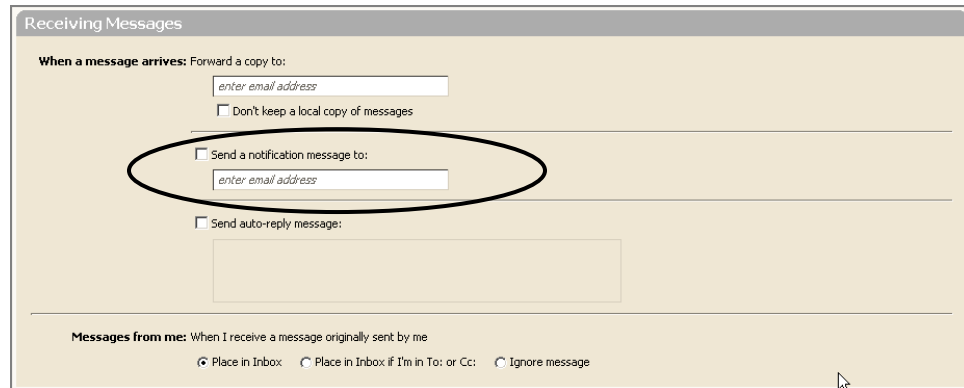

Check **Send a notification message to**.

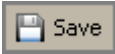
2. Enter the email address.
3. Click .

## Creating an Away Message

This feature is also known as an out-of-office auto-reply message.

- You can set an away message that automatically replies to people who send you messages when you are out of the office for an extended period of time.
- The auto-reply message is sent to each recipient only once, regardless of how many messages that person sends you during the designated vacation period.

**To set an away message:**

1. Select the **Preferences > Mail** tab, and scroll to the **Receiving Messages** area.

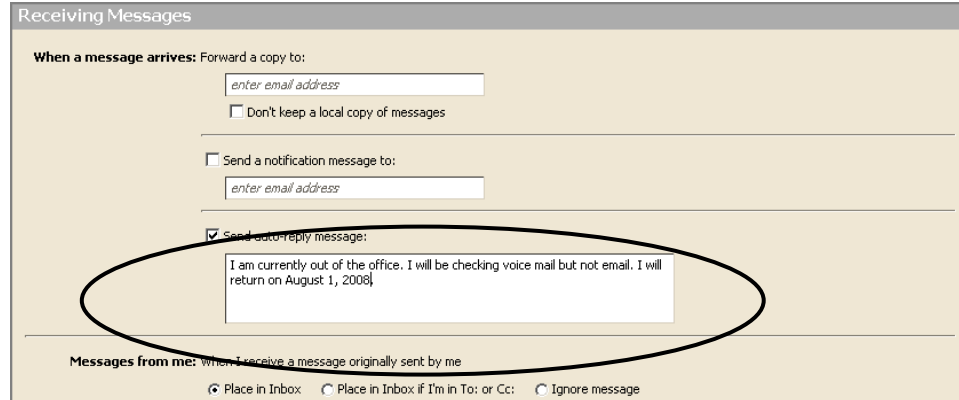

Receiving Messages

When a message arrives: Forward a copy to:

Don't keep a local copy of messages

Send a notification message to:

Send auto-reply message:

I am currently out of the office. I will be checking voice mail but not email. I will return on August 1, 2008.

Messages from me: when I receive a message originally sent by me

Place in Inbox  Place in Inbox if I'm in To: or Cc:  Ignore message

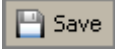
2. Check Send auto-reply message.
3. Enter the message to be sent in the text box, such as the message shown above.
4. Click  .



Remember to turn off the away message when you return. To turn off the away message, uncheck **Send auto-reply message**. The away message is disabled immediately.

## Managing Your Account Identities

There are two different aspects to account identities in ZWC:

- **Account identities.** These are also known as personas, within your Zimbra account
- **External accounts.** These are other email accounts you may have besides your Zimbra account

When you send new email or reply to or forward an email message, one identity is always associated with the email. This is the default identity or persona created as your account name and is used unless you set up different identities.

Creating different account identities, called personas, allows you to use multiple email addresses from your mailbox. You might want to do this to manage different roles in your job and personal life from this single email account.

You can also add external account addresses to your Zimbra account to retrieve email from your other POP accounts. You can configure the external account settings so that when you reply to those messages, a specific address is shown in the **From** field.

If you have set up more than one persona or added external accounts, when you open a new compose window, your identities are listed in the **Account** field in the header.

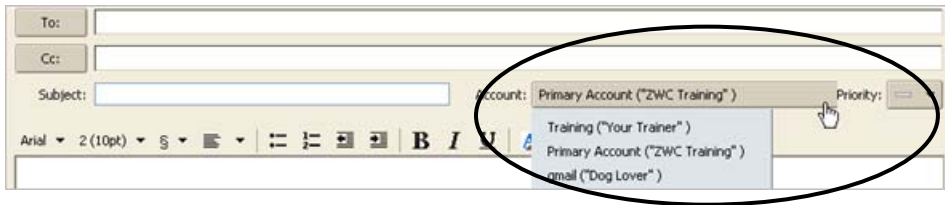



## Creating a Persona

Creating different personas allows you to use multiple email addresses from your mailbox. For example, you could use your default persona for your business email correspondence and you can create a new persona for your personal email correspondence.

### To create a persona:

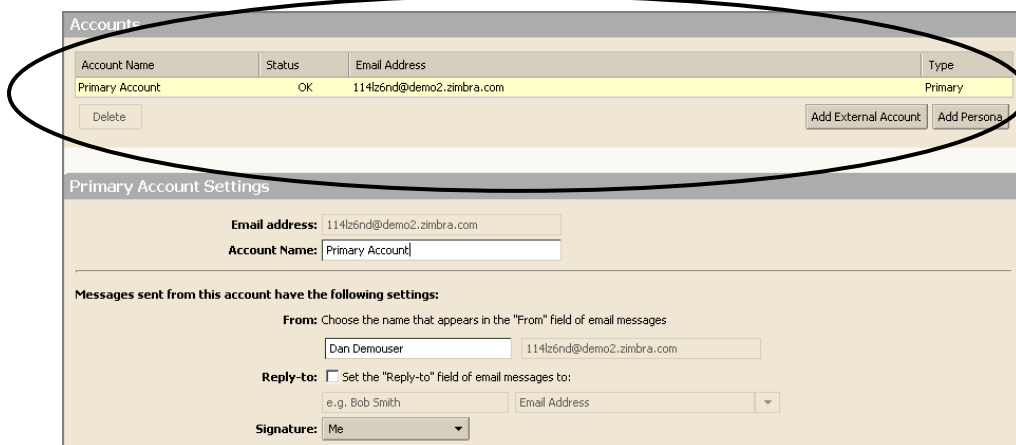
1. Select the **Preferences > Accounts** tab. Your default account information is shown at the top of the tab.



2. Click . A new account name appears, and the **Persona Settings** area appears.

Account Name	Status	Email Address	Type
Primary Account	OK	11568ou4@demo2.zimbra.com	Primary
New Persona 1	OK	11568ou4@demo2.zimbra.com	Persona

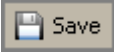
- Complete the fields in the **Persona Settings** area, as shown on the next page.
- Click  on the toolbar to save your new persona.

Complete the fields in the **Persona Settings** area, as shown in this example where a **Training Persona** is created to manage all emails related to training.

**Persona Settings**

Use personas to quickly change many settings when sending email messages. For example, if you sometimes send email in a particular role at work, create a persona for that role.

**Persona Name:**

---

**Messages sent from this account have the following settings:**

**From:** Choose the name that appears in the "From" field of email messages

**Reply-to:**  Set the "Reply-to" field of email messages to:

**Signature:**

---

**Use this persona:**  When replying or forwarding messages sent to:

Enter email addresses separated by commas or semi-colons

Replying to or forwarding messages in folder(s):



Enter folder names separated by commas or semi-colons

- Enter a name for this persona in the **Persona Name** field. This is the name used to identify the persona in the **From** list when you are composing an email. It does not appear in the email message.
- Specify the **From** information for this persona:
  - Type the name that should appear in the **From** field of your outgoing email messages. This is the friendly name that is shown before your email address.
  - Select the email address from which to send messages into the second field. If this field is not editable, you do not have additional external accounts identified.
- To direct replies to emails from this persona to a name and address different from that which you configured in **From**.
  - Check **Set the "Reply-to"** field of email messages to.



- Enter the name and address that should receive replies for this identity. For example, replies to training messages should be sent to **Team Training** at **training@yahoo.com**.
8. Select a signature for this persona using the **Signature** drop-down menu.
    - If you have not created the signature, you can come back and edit this persona later.
    - If you do not want the signature to be applied automatically, select **Do Not Attach Signature** from the menu.
  9. To automatically use this persona when replying to messages sent to a specific email address, or when forwarding messages from that address:
    - Check **When replying or forwarding messages sent to**.
    - Type the email address(es) in the field. If you are entering more than one email address, separate addresses with either a comma or a semi-colon.
  10. To automatically use this persona when replying to messages in a specific folder, or when forwarding messages from this folder:
    - Check **Replying to or forwarding messages in folder(s)**.
    - Click the folder icon to select one or more folders from the list of existing folders or to create a new folder.
    - If you are selecting more than one folder, separate the folder names with either a comma or a semi-colon.

To create a signature for use with this persona, use the **Preferences > Signature** tab. Refer to **Email Signatures** in Chapter 3 for instructions on creating email signatures.

## Retrieving Email from an External Account

Using ZWC, you can link your external email accounts to your Zimbra mailbox. Then, you can retrieve email from your external account(s) in your ZWC, instead of logging into each external account separately.

When you set up your external account on ZWC, you can:

- Specify where the messages will be saved



- Create a persona to be used when you reply to or forward a message received from that external account

## Information You Need



When you set up your external account you need to know the following details. You may need to contact your email provider for this information.

- **Account type.** This is the type of email you service provider uses: POP or IMAP.
- **User name on the account.** This is the user name associated with this email account. Sometimes your user name is the part of your email address before the @ and other times it is your full email address.
- **Email server.** This is the server name for your external account.
- **Advanced settings.** Your provider should let you know if they do not use a standard IMAP (143) or POP (110) port. Enable **Use an encrypted connection (SSL) when accessing this server** when you need to connect securely to the external server. The port numbers will change.

## Receiving Messages from Your External Account

When you retrieve your external email messages, the messages and attachments are saved to the folder you specify when you configure your account information.

Messages from your external account(s) are not automatically received in your Zimbra Web Client account. To check for email from your external account(s):

- If you configured the **Inbox** to be the folder to save the external account's messages, click  on the toolbar. Your Inbox folder is updated with all new messages including messages from your external accounts.
- If you configured another folder for your external accounts, select that folder and click the  button on the toolbar. Messages are delivered to your folder.
- If you configured another folder for your external accounts, right-click the folder. The menu has a **Get External Mail** option. Select this option to receive messages.

## Adding an External Account

To add an external account to your ZWC account:

1. Select the **Preferences > Accounts** tab. Your default account and persona information is shown at the top of the tab. In this example, a persona has already been created.



Account Name	Status	Email Address	Type
Primary Account	OK	11568ou4@demo2.zimbra.com	Primary
Training Persona	OK	11568ou4@demo2.zimbra.com	Persona

2. Click . A new external account name is added to your accounts, and the **External Accounts Settings** area appears.

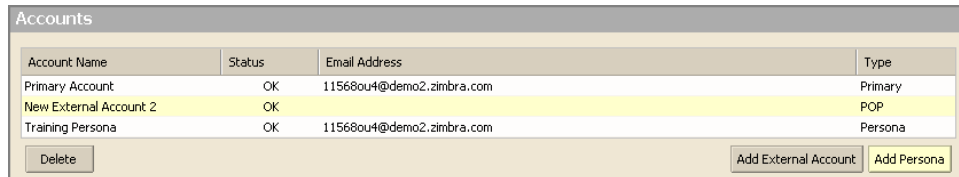

Account Name	Status	Email Address	Type
Primary Account	OK	11568ou4@demo2.zimbra.com	Primary
New External Account 2	OK		POP
Training Persona	OK	11568ou4@demo2.zimbra.com	Persona

3. Complete the fields in the **External Accounts Settings** area, as shown on the next page.
4. Click  on the toolbar to save the external account settings.

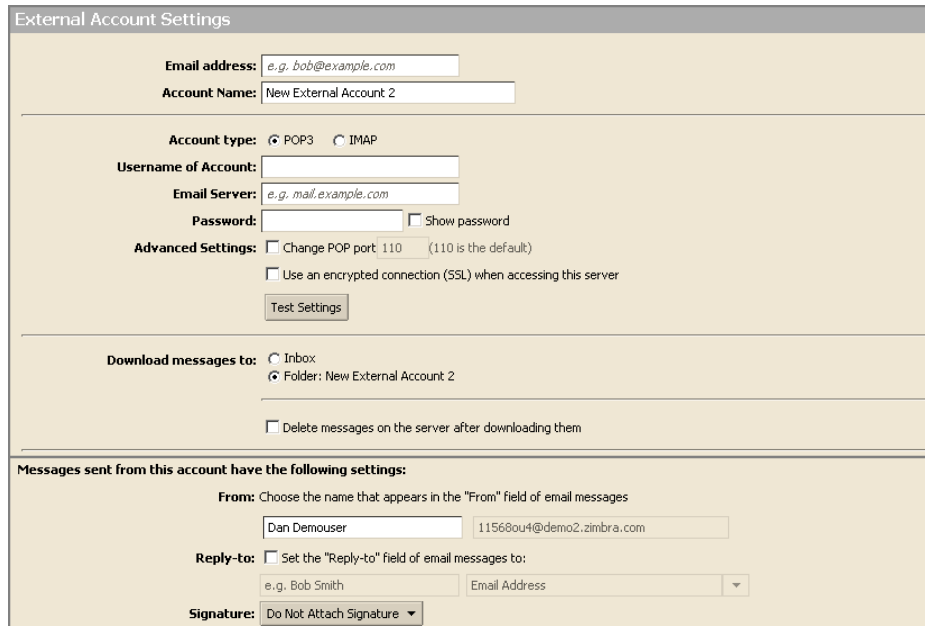

**External Account Settings**

Email address:

Account Name:

Account type:  POP3  IMAP

Username of Account:

Email Server:

Password:   Show password

Advanced Settings:  Change POP port: 110 (110 is the default)

Use an encrypted connection (SSL) when accessing this server

Download messages to:  Inbox

Folder: New External Account 2

Delete messages on the server after downloading them

Messages sent from this account have the following settings:

From: Choose the name that appears in the "From" field of email messages

Reply-to:  Set the "Reply-to" field of email messages to:

Signature:



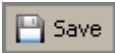

5. Enter the exact email address of the external account in the **Email Address** field.
6. Enter a name to identify this account into **Account Name** field in the **External Account Settings** section. You can select this account name from the From address list when you compose new email messages.
7. Check the **Account type**: POP or IMAP.
8. Enter the name of this email account into the **Username of Account** field.
9. Enter the email server host name into the **Email server** field.
10. Enter the password you use to log on to this external account in the **Password** field. To see that the password you typed is correct, check **Show password**.
11. If your service provider uses a different port than the default, change it in the **Advanced Settings** area. If you use a secure connection, enable **Use an encrypted connection (SSL) when accessing this server**.
12. Select where the messages should be saved using the **Download messages to** section. The default is to create a new folder and enable it to receive the messages. But if you want the messages in your Inbox, select Inbox.
13. Enable **Delete messages on the server after downloading them** if you want the message deleted from your external account when it is sent to your ZWC account.
14. Type the name that should appear in the **From** field of your outgoing email messages (for example, John). This is the friendly name that is shown before your email address.
15. Check **Reply-to** if replies should be sent to a name and address different from that which you configured in **From**. Enter the name and address that should receive replies for this identity. For example, replies to training messages sent by John should be sent to **Team Training** at **training@example.com**.
16. Select a signature for this external account using the **Signature** drop-down menu.
  - If you have not created the signature, you can come back and edit this external account later.
  - If you do not want the signature to be applied automatically, select **Do Not Attach Signature** from the menu.
17. Click  on the toolbar to save your new external account settings.

To create a signature for use with this external account, use the **Preferences > Signature** tab. Refer to **Email Signatures** in Chapter 3 for instructions on creating email signatures.

## Subscribe to an RSS

You can subscribe to Web sites that provide your favorite RSS (Really Simple Syndication) and podcast feeds to send updated information directly to your mailbox.

You need to know the URL for the RSS before proceeding.

To subscribe to an RSS feed:

1. Click  above the **Folders** heading in the Overview pane. You must create a separate folder for each RSS feed.

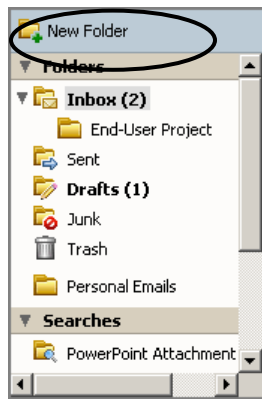

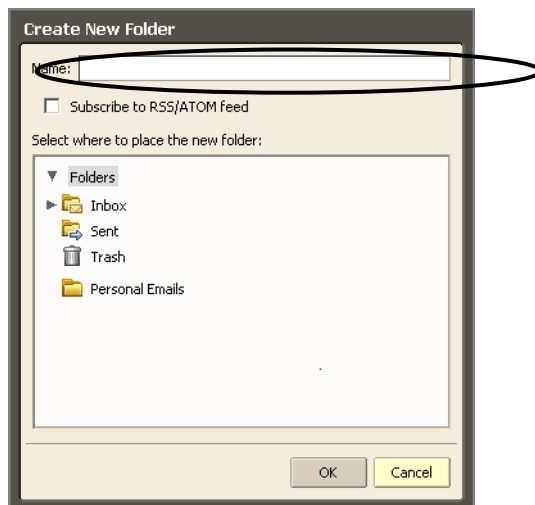

The **Create New Folder** dialog appears.

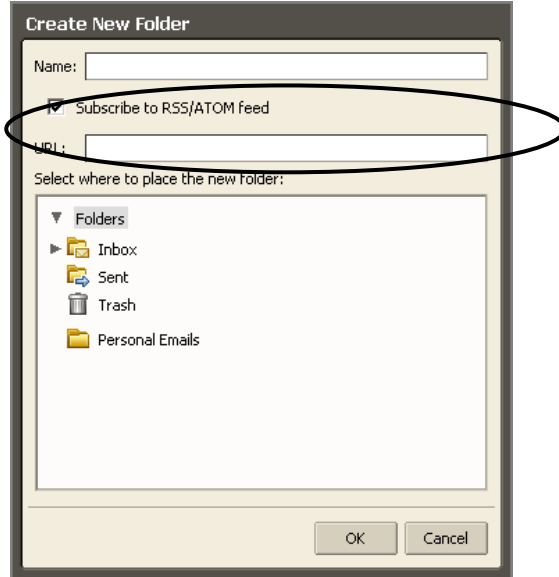

2. Type the name of the RSS feed folder in the **Name** field.
3. Check **Subscribe to RSS/ATOM feed**. The URL field is displayed in the dialog.

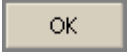

4. Enter the URL for the feed in the **URL** field.
5. Select where to add the RSS feed folder in the folder menu. If you choose the root folder, the new folder is displayed at the highest level in your folder view, which is the same level as your Inbox folder.
6. Click . The new folder, with the RSS feed icon , displays as the folder in your Overview pane. The feed is automatically sent to the folder in your Zimbra mailbox.

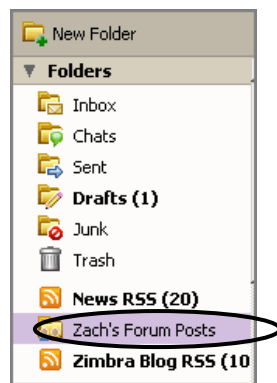

7. Open the RSS folder. The content is displayed in the Content pane.

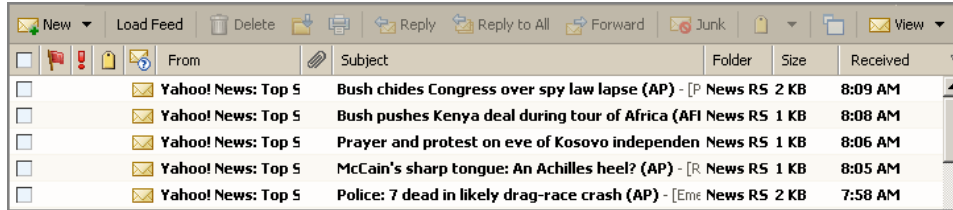

8. Click  in the toolbar to update the content.

## Mailbox Quotas

To keep disk and resource usage to a manageable level, your administrator may enforce quotas to limit the amount of disk space your mailbox can consume.

The display banner under your name in the shows a bar showing how much of your quota you have used.

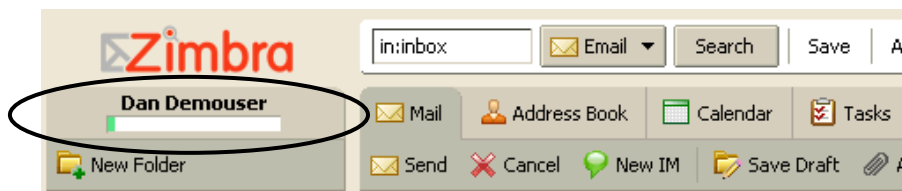

If you are over quota, the following things may happen:

- You receive an email notification.
- Your email interface displays a notification when you log in.
- Email sent to you may be returned (bounced), along with a notification that your mailbox is full.

To reduce the size of your mailbox:

- Delete old messages that are no longer needed.
- Look for and delete messages with large file attachments. Save the file attachments locally if you want to preserve them.
- Delete Documents notebooks, pages, images and attachments that are no longer needed.
- Empty the Trash and/or Sent folders.

Zimbra also supports automatic purging of messages that are over a certain number of days old. Your administrator sets the policy for when messages are purged, how old they have to be, and which folders are purged.

## Changing Your Default Time Zone

Change the default time zone for your mailbox using the **Login Options** area of the **Preferences > General** tab.

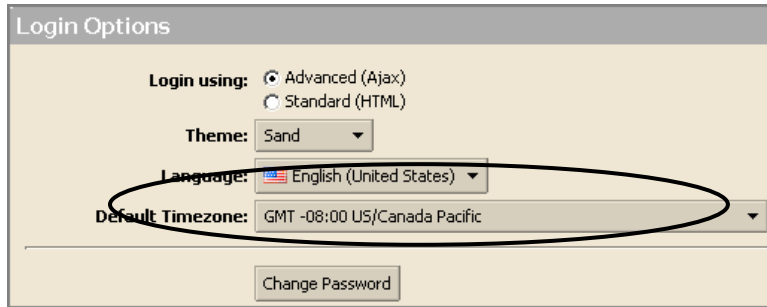

The default time zone setting that is displayed in this tab is used to localize the time for received messages and calendar activities in the standard web client. The advanced web client uses the the timze zone setting on the computer as the time stamp for received messages and calendar activities, not the time zone setting in the General tab.



## 7 Managing Your Address Books

---

### This chapter explains how to...

- View your address books
- Add new contacts to specific address books
- Add names to email from your address books
- Add contacts automatically to your address books
- Create group contact lists
- Import or export your address book

Your email administrator can set a maximum limit for the number of entries you can have in all of your address books. When you reach this maximum, you cannot add any more contacts. However, you can delete unused contacts to free up space.

When you compose an email, the auto-complete feature displays a list of names from your address books that match the text you are typing.



The **Emailed Contacts** address book is populated automatically when you send an email to a new address that is not in one of your other address books. You can disable this feature by removing the check from **Enable auto adding of contacts** on the **Preferences > Address Book** tab.

### Viewing Your Contact Information

You can view the contact names in a list or as detailed cards.

- The **Contact List** view is a vertical list of all of your contacts.

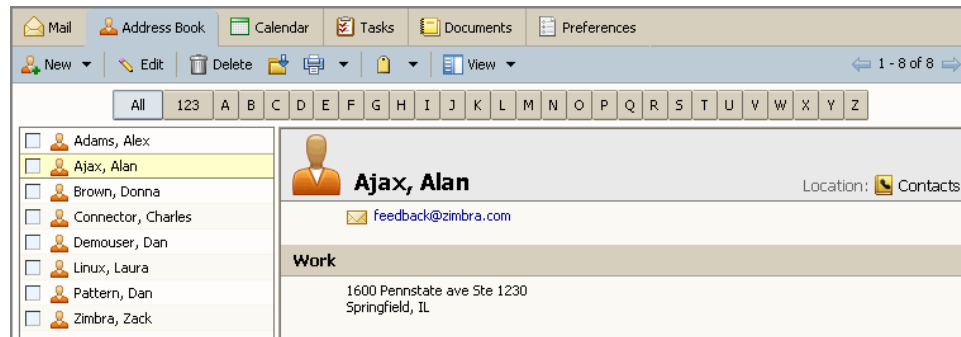

- The **Detailed Cards** view shows all the information you entered on the contact form.

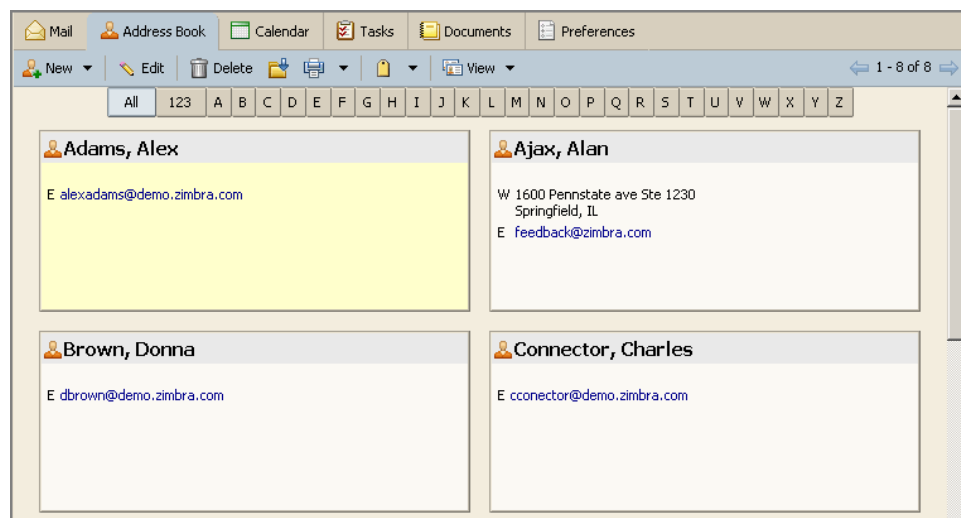

To change the view for one session, use the **View** drop-down menu on the toolbar.

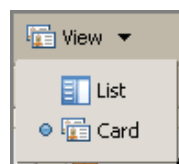

**To change the default view for Address Books:**

1. Select the **Preferences > Address Book** tab.
2. Select an option from the **Default View** drop-down menu in the **Options** area.



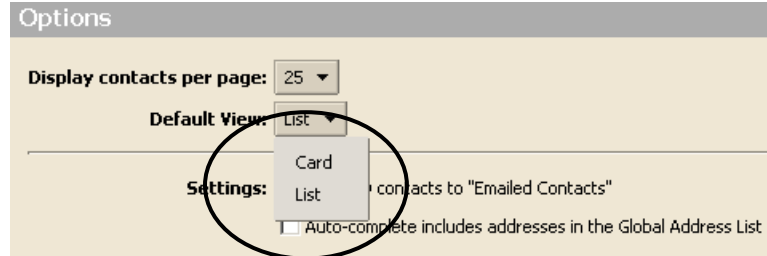

When you pass your mouse cursor over an address, a tool tip displays the full email address associated with that name. If the name is already in an address book, both contact information is displayed. If the name is not in one of your address books, only the email address is displayed.

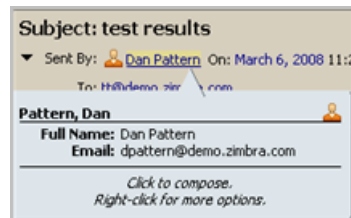

## Adding a New Contact

You can add a new contact in two ways:

- Using  on the toolbar.
- Right-clicking a name in a message header and choosing **Contacts**.

When you add a new contact, you:

- Enter the name, phone, and company information
- Select how you want to file the contact in your list
- Enter up to three email addresses and three mailing addresses

### Adding a new contact from the toolbar

1. Click the arrow next to  on the toolbar, and select **New Contact**.

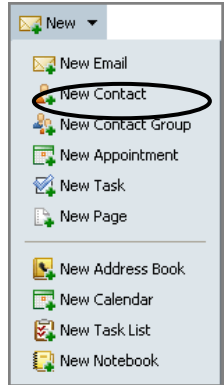

The **New Contact** form opens.

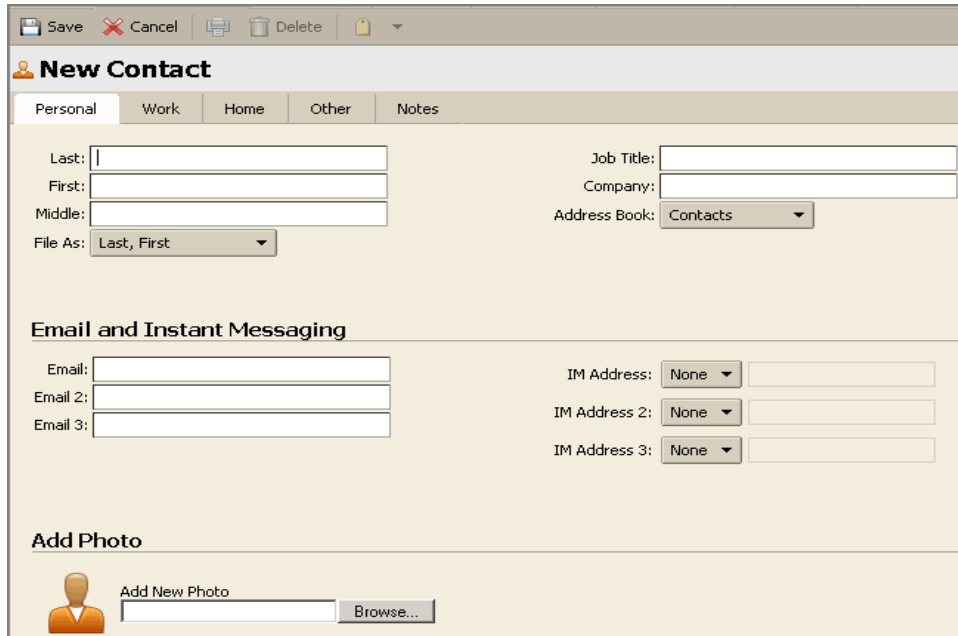

2. Enter the contact information, and upload a photo of this contact, if desired.
3. Click  on the toolbar.

### Adding a new contact from an existing email message:

1. Open the email message, the header is displayed in gray at the top of Message the Detail pane. You can add email addresses from the **Sent By**, **To**, **Cc**, and **Bcc** fields.

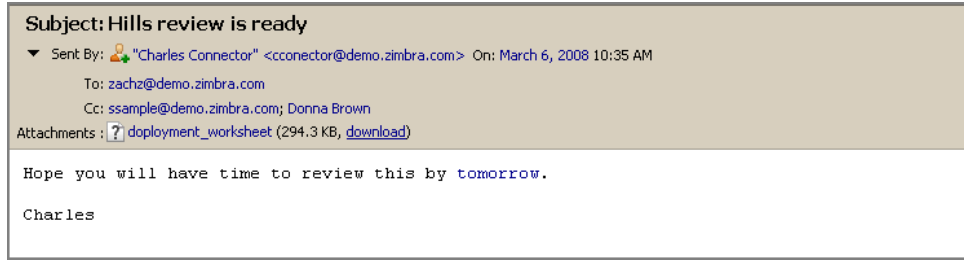

- Right-click the name to add to your contact list and choose **Add to Contacts**.

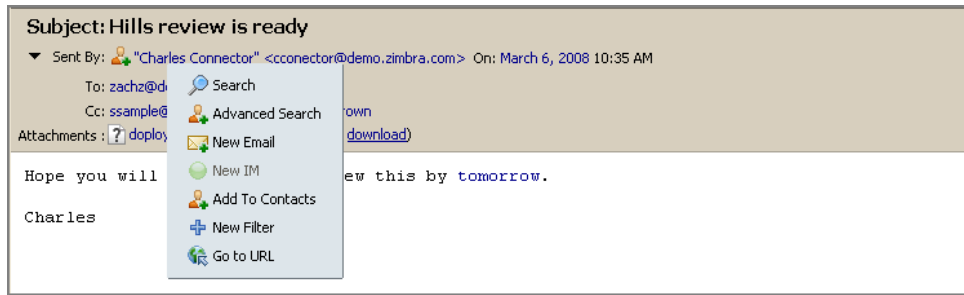

- The **New Contact** form opens pre-populated with whatever information was available from the email header. Add additional information and check the pre-populated fields for accuracy.



4. Select the following:
  - With **File As**, select how you want to file the name. The default is to file the contact by last name, first name.
  - With **Address Book** select the address book to which you want to save the name.
5. Click  on the toolbar.

## Adding Names to Email from an Address Book

When composing an email, you can select email addresses from your address books.

### Company Address Book

Within your organization, you may not always know the correct email address to use. For example Joe Smith at Acme could variously be **joe@acme.com**, **jsmith@acme.com**, or **js123@sales.acme.com**.

A company address book (also known as a Global Address List), is usually available to everyone in the company to help identify email addresses.

### To add names from an address book to a new email message:

1. Click  on the toolbar to open a new message.
2. Click **To**. An address selection dialog appears. Complete the remaining steps as described on the next page.

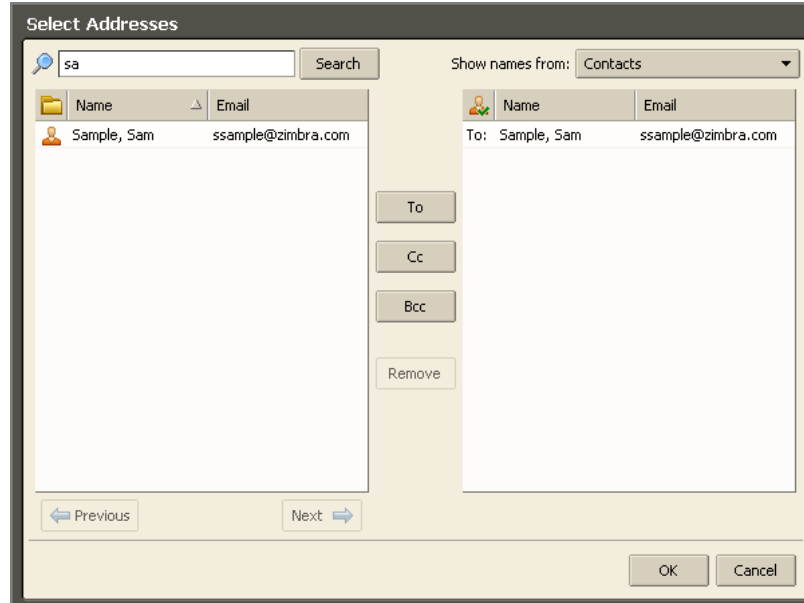

3. Select an address book from the **Show names from** list. In the example above, **Contacts** is selected. The graphic below shows some options in this menu.

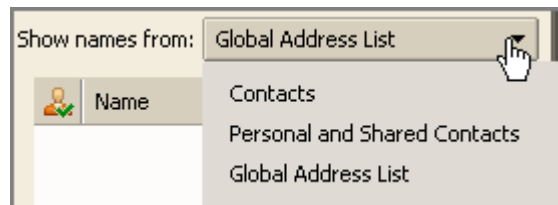

4. Enter a name or portion of a name in the **Search** field on the left.
5. Click **Search**. A list of names and email addresses appears on the left. In this example, Sam Sample is displayed because it matches the **sa** entered into the **Search** field.
6. Select a name to add it to the recipients list on the right.
7. Click the **To**, **Cc**, and **Bcc** buttons to determine where the name will appear when the message is addressed. Click the desired button before moving the name across. Use the **Remove** button to remove a name from the recipients list on the right.
8. Repeat the search as needed until all names have been added.
9. Click .

## Adding Contacts Automatically

Using the **Preferences > Address Book** tab, you can select the **Add new contacts to “Emailed Contacts”** option to automatically add email addresses from your email messages to your Emailed Contacts list. With this feature enabled, any time you respond to a message that includes an email not in your address books, the address is automatically added to your Emailed Contacts address book.

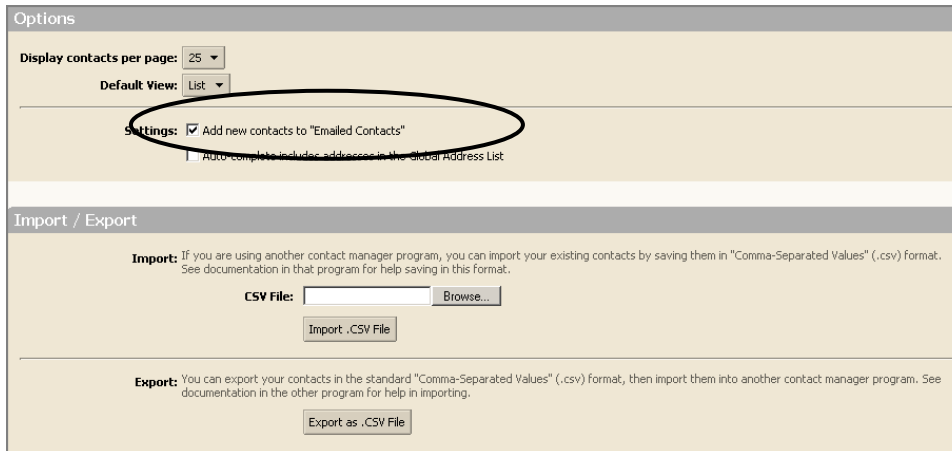

The Email Contact address book lets you keep a separate miscellaneous address book from other address books with random addresses.

## Creating a Group Contact List

The Group Contacts feature allows you to create contact lists, also known as email aliases, that contain multiple mailing addresses. When you select a group contact name, everyone whose address is included in the group list is automatically added to the address field of the message.



The icon  indicates that a contact name is a group contact.

**To create a group contact list:**

1. Right-click  on the toolbar and select **New Contact Group**.

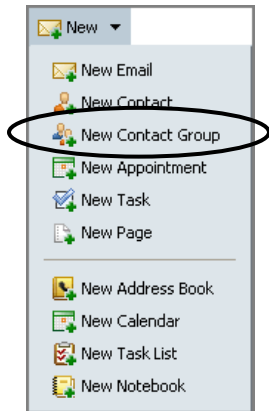

The **New Contact Group** form is displayed.

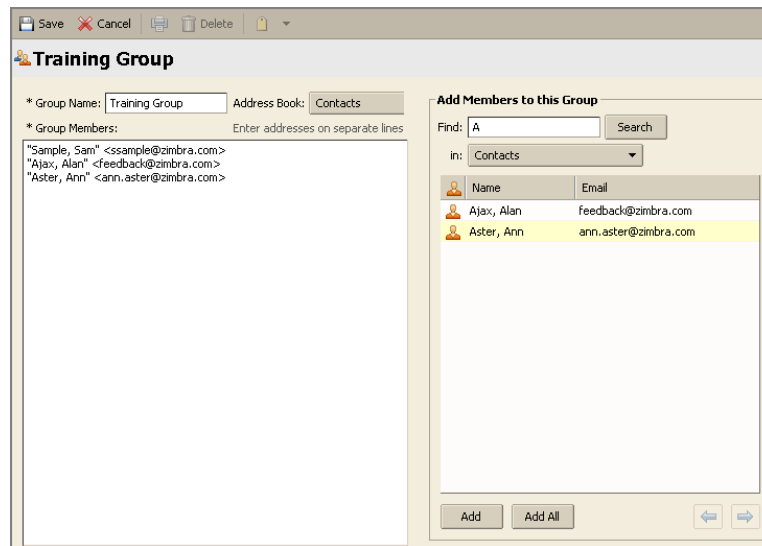

A screenshot of the 'Training Group' form. The form has a title bar with 'Save', 'Cancel', 'Delete', and a lock icon. The main content area is divided into two sections. The left section is titled '\* Group Name:' and contains a text field with 'Training Group' and an 'Address Book:' dropdown menu with 'Contacts' selected. Below this is a '\* Group Members:' section with a text area containing three entries: '"Sample, Sam" <ssample@zimbra.com>', '"Ajax, Alan" <feedback@zimbra.com>', and '"Aster, Ann" <ann.aster@zimbra.com>'. The right section is titled 'Add Members to this Group' and contains a 'Find:' text field with 'A', a 'Search' button, and an 'In:' dropdown menu with 'Contacts' selected. Below this is a table with two columns: 'Name' and 'Email'. The table contains two rows: 'Ajax, Alan' with email 'feedback@zimbra.com' and 'Aster, Ann' with email 'ann.aster@zimbra.com'. The second row is highlighted in yellow. At the bottom of the right section are 'Add' and 'Add All' buttons, and navigation arrows.

2. Type the name for this Contact Group into the **Group Name** field.
3. Select the address book to which you want to add this Contact Group from the **Address Book** drop-down menu.
4. To add members to this group:
  - o Type a name into the **Find** field.
  - o Select the address book you want to search using the **in** drop-down list.

Names that match your entry are listed in the box below the **Find** field.

5. Select the names to enter and click **Add** or **Add All**. The names are added to the **Group Members** list.
6. You can also type email addresses directly in the **Group Members** list box. Separate addresses with either a comma (,) or a semicolon (;), or using Return.
7. Click  on the toolbar. The new group contact is added to your address book.

## Importing an Address Book

You can import contact lists and address books that are saved in a comma-separated (.csv) text file format.

### To import an address book:

1. Select the **Preferences > Address Book** tab.

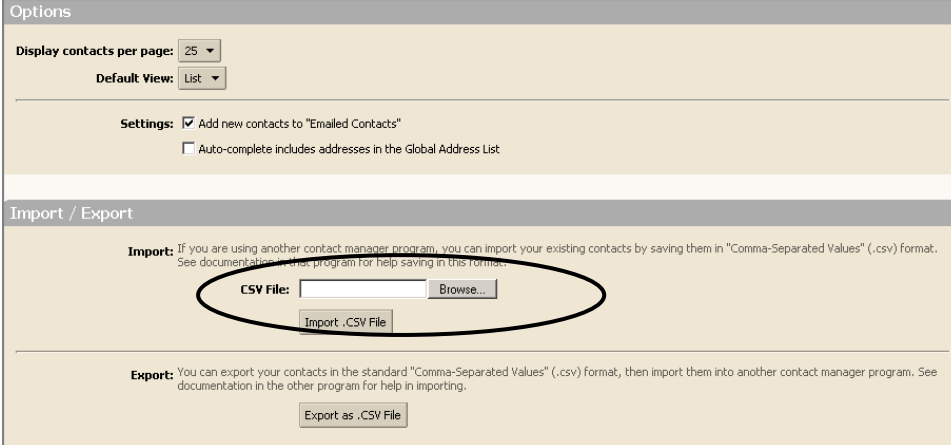

The screenshot shows the 'Options' dialog box with the 'Import / Export' section selected. The 'Import' section is circled in black. It contains the following text: 'Import: If you are using another contact manager program, you can import your existing contacts by saving them in "Comma-Separated Values" (.csv) format. See documentation in that program for help saving in this format.' Below this text is a 'CSV File:' text input field, a 'Browse...' button, and an 'Import .CSV File' button. The 'Export' section below it contains the text: 'Export: You can export your contacts in the standard "Comma-Separated Values" (.csv) format, then import them into another contact manager program. See documentation in the other program for help in importing.' and an 'Export as .CSV File' button.

2. Click **Browse** in the **Import / Export** area to locate the .csv file to import.
3. Browse to the .csv file you want to import.
4. Double-click the .csv file in the **File Upload** dialog.
5. Click **Import .CSV File**. The Choose Address Book dialog appears with a list of your address books.
6. Select the address book to import into or create a new address book.
7. Click **OK**.



Depending on the size of the .csv file, import may take a few minutes. When the import is complete, the **Status Box** shows the number of contacts successfully imported. Contacts are alphabetized by last name.

## Exporting an Address Book

Your address books are exported and saved in a comma-separated (.csv) text file format.

### To export an address book:

1. Select the **Preferences > Address Book** tab.

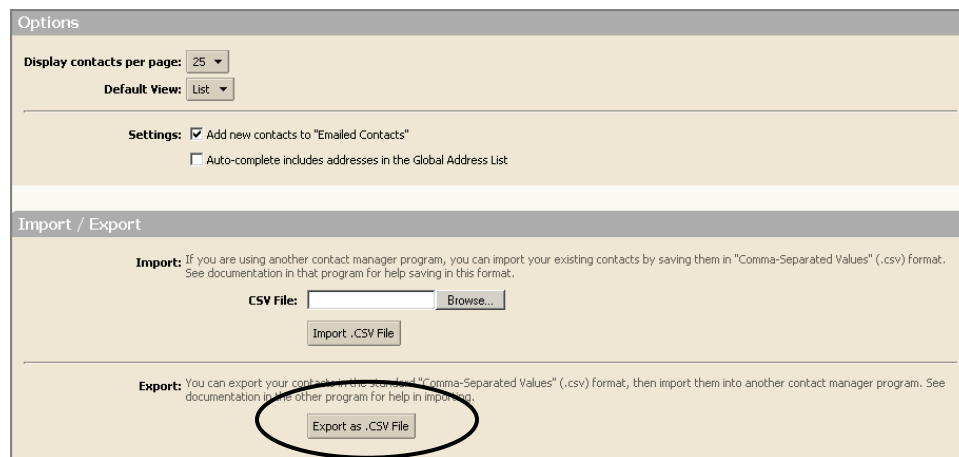

2. Click **Export as .CSV File**. The Choose Address Book dialog appears with a list of your address books.

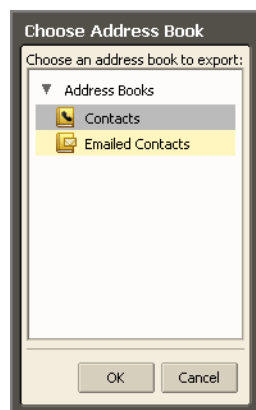

3. Select the address book to export.
4. Click **OK**. An **Opening Contacts.csv** dialog appears.

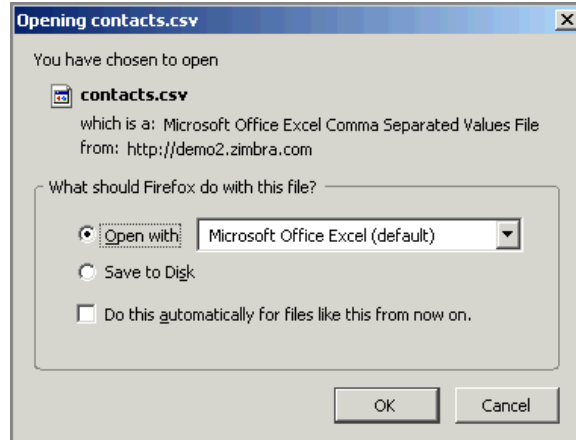

5. Check **Save to disk** and click **OK**.
6. Select where to save the file and enter a file name. The default name is **Contacts.csv**.
7. Click **Save**.

## Printing a Contact Name or Address Book

You can print a complete address book or just print the information for one contact.

### To print from address books:

1. Select an Address Book a
2. To print, either:
  - Select a specific contact name and click the Print icon .
  - Click the arrow next to the print icon and select Print Address Book.

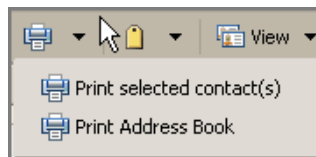

For Group Contact lists, if the list is long, only the first few names on the list are printed and **More...** displays, to let you know that there are additional names that were not printed.

## Editing Contact Information

To open a contact for editing:

1. From the **Contacts** area, right-click the contact to be modified and choose **Edit Contact**.

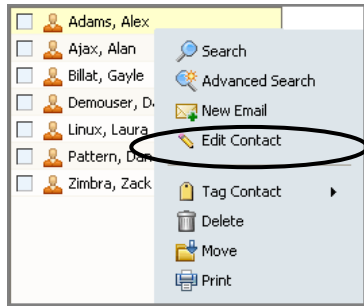

The **Edit Contact** form appears.

The 'Edit Contact' form for 'Ajax, Alan'. The form has a title bar with 'Save', 'Close', 'Print', 'Delete', and 'Lock' icons. Below the title bar are tabs for 'Personal', 'Work', 'Home', 'Other', and 'Notes'. The 'Personal' tab is active. Fields include: Last: Ajax, First: Alan, Middle: (empty), File As: Last, First (dropdown), Job Title: (empty), Company: (empty), Address Book: Contacts (dropdown). The 'Email and Instant Messaging' section has: Email: feedback@zimbra.com, Email 2: (empty), Email 3: (empty), IM Address: None (dropdown), IM Address 2: None (dropdown), IM Address 3: None (dropdown). The 'Add Photo' section has a photo placeholder and an 'Add New Photo' button.

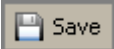
2. In the **Edit Contact** form, make any changes.
3. Click  to commit your changes.

### To move a contact to another address book:

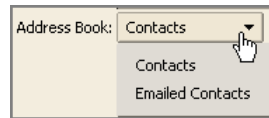

1. From the **Contacts** area, right-click the contact to be modified and choose **Edit Contact**.
2. Select the address book where you want to move the contact using the **Address Book** drop-down menu.



3. Click  **Save**.

## Deleting Contacts

Any contact lists you create can be deleted. Contacts can be deleted in one of three ways:

- From an address book, select the contact to be removed, and click  on the toolbar.
- Drag the contact name to the **Trash** folder.
- Right-click on the contact and select .

When contact names are deleted, they no longer appear in your address book and information is not available from the name tool tips for the address auto-completion or from the address search dialog in the email compose window.



If you delete a contact that was automatically added to your address book, the contact is moved to the Trash folder. You cannot add the name back to your address books until you delete the contact from the Trash folder.

## Sharing Your Address Books

You can share any of your address books. This is useful if your address books are for specific categories of contacts and what other users to have access to the names. Depending on the role you assign to the grantee, the shared contacts list can be view-only or can have full access privileges to edit, add, and delete names.

To learn more about how to share your address books, see Chapter 15, *Sharing Your Account Items*.



## 8 Managing Your Calendar

---

**This chapter explains how to...**

- Choose a calendar view
- Create calendars
- View multiple calendars
- Import and export your iCal calendars
- Print a calendar
- Delete a calendar

The Zimbra Calendar lets you track and schedule your appointments, meetings, and events.

### Displaying the Calendar View

To open the Calendar view, select the **Calendar** tab in ZWC. The Work Week view is the default and is displayed when Calendar is opened the first time.

You can change which view is displayed when Calendar is opened from the **Preferences > Calendar** tab.

You can change your view from the **Calendar** toolbar, to see activities for a day, work week, full week, or month. Changing the Calendar view from the toolbar only changes the view for that session.

### Creating a Calendar

One calendar is created for you, and you can create additional calendars to keep track of different type of functions. For example, you can create one calendar for work, one for personal appointments, and one for company activities. Use the Schedule view the see calendars side-by-side.

**To create a calendar:**

1. Select the **Calendar** tab in the ZWC.
2. Either:
  - o Right-click **Calendars** in the Overview pane and select **New Calendar**.

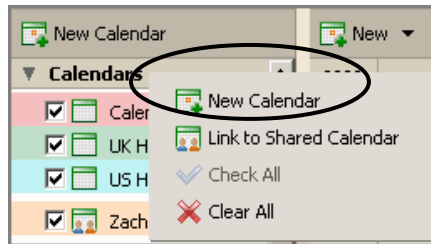

- o Right-click  on the toolbar and select **New Calendar**.

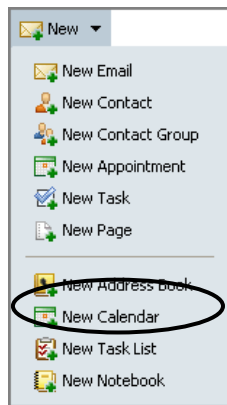

The **Create New Calendar** dialog appears.

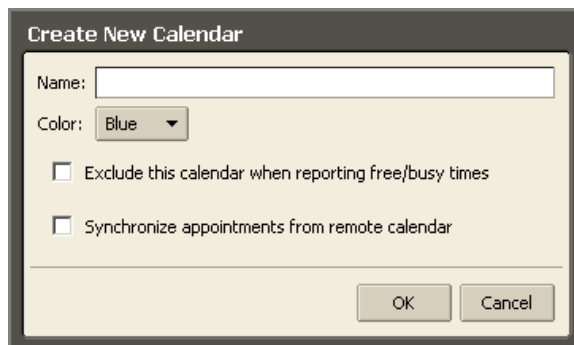

3. Type the name of the calendar into the **Name** field.
4. Select a color for displaying the Calendar's activities using the **Color** menu.



5. Select the other options if necessary:
  - **Exclude this calendar when reporting free/busy times.** The appointments on this calendar will not be displayed when you view free/busy times.
  - **Synchronize appointments from remote calendar.** When you select this option, a **URL** field appears. Enter a valid iCal file URL for the remote calendar.

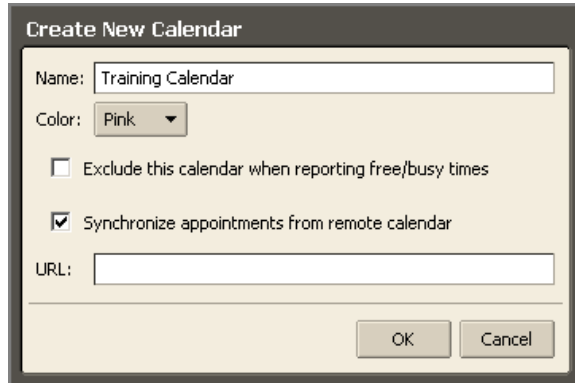

6. Click **OK**. The new calendar displays in the Calendar list.

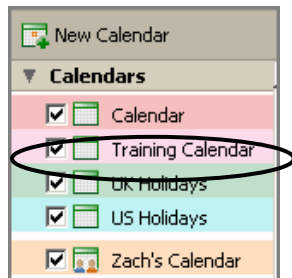

## Adding Color to a Calendar

You can color-code calendars in your mailbox so that activities for that calendar always display in the selected color. When you are looking at activities from all calendars in one view, the color signifies activities on different calendars. There are eight colors available, and you can use a color more than once.

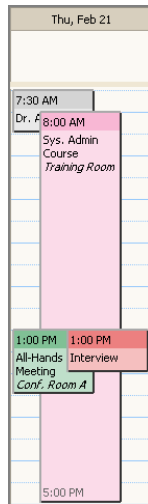

The above shows that gray, green, pink, and red calendars have activities on February 21, and the pink calendar has an all-day event.

### To select a color for a calendar:

- Select a color when you create a calendar.
- Select a color when you accept a calendar to share.
- Edit the calendar's properties to change the color.

## Viewing Multiple Calendars



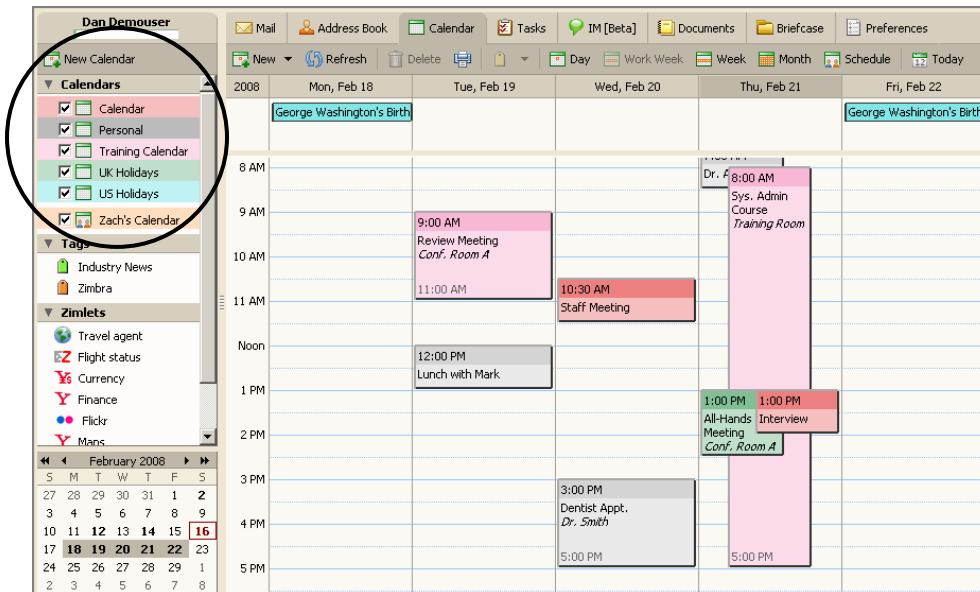

All of your calendars, including shared calendars, are visible in your Calendar list. Each calendar has a check box to the left of its name. Check the boxes for the calendars you want to view.

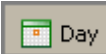

The Work Week view is displayed by default, as shown above. You can change your view:

- For this session only by clicking options on the Calendar toolbar.
- For the default view using the **Preferences > Calendar** tab.

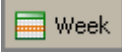
The views are as follows:

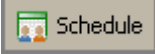
-  **Day** is one day's activities.
-  **Work Week** displays Monday through Friday activities.
-  **Week** displays seven days of activities.
- Select which day is the first day of the week view using the **Preferences > Calendar** tab.
-  **Month** displays a month's activities.
-  **Schedule** displays each calendar in a separate column.

- The **All** column is a color-coded free/busy indicator for the viewed calendars. White indicates no activity. The deeper the red in this column, the more overlapping appointments.
- Move the mouse over the **All** column for tool tips that show which calendars have activity scheduled within a time period.

## Importing Your iCal Calendar

You can import iCalendars (iCal) calendars that are saved in the .ics format. iCalendars are the standard for calendar data exchange over the Internet, and .ics is the standard format for iCalendar information.

### To import an iCal calendar:

1. Select the **Preferences > Calendar** tab.
2. Scroll down to the **Import / Export** area.

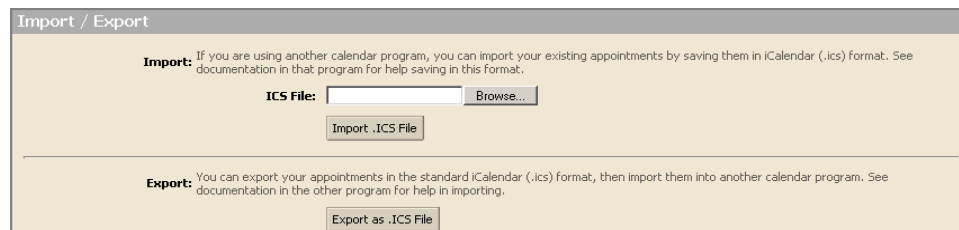

3. Click **Browse** to locate the .ics file to import.
4. Click **Import**.
  - If you want to add this calendar to an existing calendar, select the calendar to import into.
  - You can also create a new calendar.
5. Click **OK**.

Depending on the size of the .ics file, the import may take a few minutes.

## Exporting Your iCal Calendar

You can export calendars in the .ics format.

**To export an iCal calendar.**

1. Select the Preferences > Calendar tab.
2. Scroll down to the **Import / Export** area.

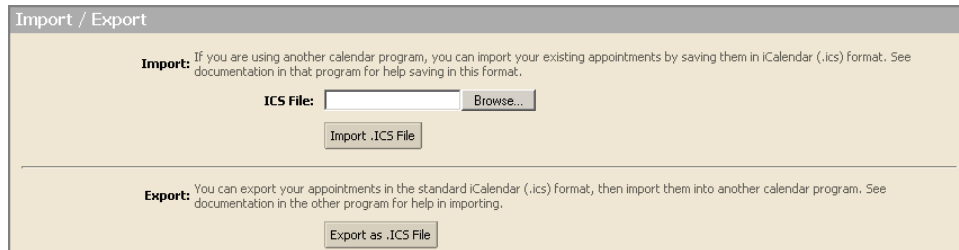

3. Click Export as .iCS File. The Choose Folder dialog appears.

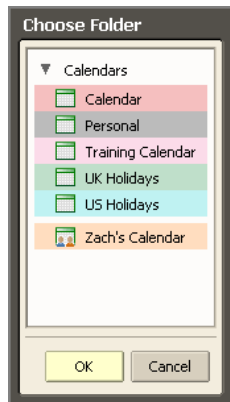

4. Select the calendar to export.
5. Click **OK**. The Opening training calendar.ics dialog appears.

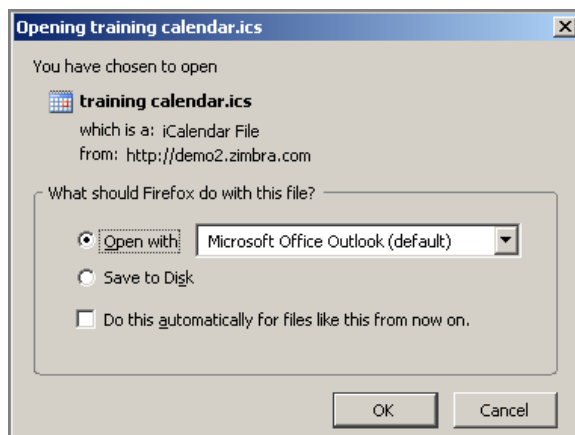

6. Click **Save to Disk** and click **OK**.



7. Select where to save the file and enter a file name.
8. Click **Save**.

## Sharing Your Calendars

You can share your calendars with other people in your office, with external guests, and with the public. This can be useful if you maintain different calendars and want others to know your schedule. When you share your calendars with internal users, you can select the type of access the internal users can have, either manager which gives full access to view and modify the calendar, or viewer, which gives read-only access. External guests and the public have read-only access.

To learn more about how to share your calendars, see Chapter 15, *Sharing Your Account Items*.

## Printing a Calendar

You can print individual calendars in any of the views. The printed schedule includes present and previous month calendar and meetings displayed per day.

If you view more than one calendar and then print that view:

- All schedules are combined on one calendar.
- The printed calendar does not specify the calendar's name.

### To print a calendar:

1. Display any calendar view.
2. Click  on the toolbar. Your printer dialog appears, and the Calendar view to be printed displays. The example below is a Day view.

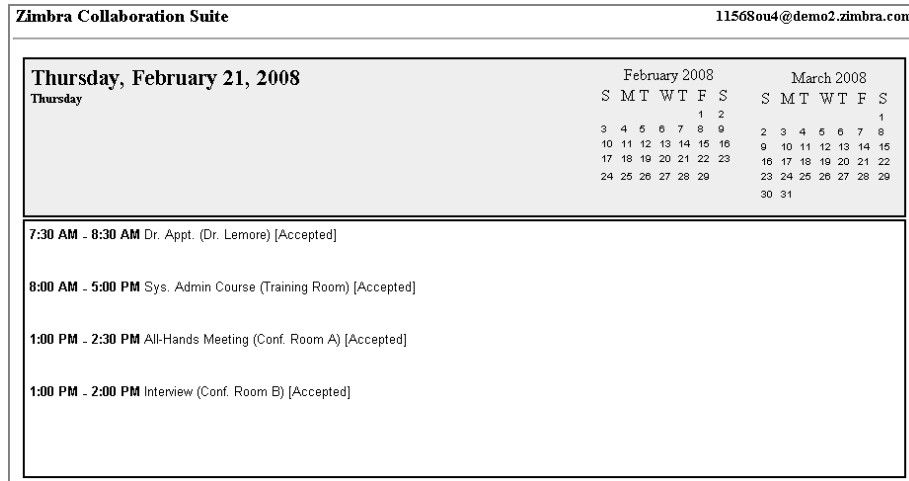

3. Click **OK** on your printer dialog. Close the Calendar Print view.

## Deleting a Calendar

You can delete any calendar in your Calendars list, except your default calendar.

### To delete a calendar:

1. Right-click on the calendar to be deleted.
2. Click **Delete**. The **Confirmation** dialog appears.

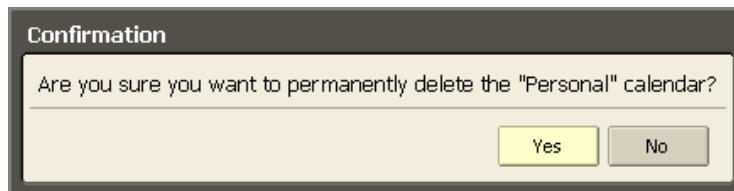

3. Click **Yes**.

The calendar is immediately deleted. There is no undo. However, the meetings that were created from this calendar are not automatically deleted from invited attendee's calendars







## 9 Scheduling Appointments, Meetings, and Events

---

### This chapter explains how to...

- Create an appointment, meeting or event
- Use QuickAdd to quickly create an appointment
- Create recurring appointments or meetings
- Change an appointment or meeting
- Turn a message or a contact into a meeting request
- Respond to an invitation

Activities you schedule on a calendar are either appointments, meetings, or events.

- **Appointments.** An appointment is an activity without other people. When you schedule an appointment, no email is sent to confirm the appointment. You can set recurring appointments. **QuickAdd** can be used to quickly create an appointment.
- **Meetings.** Meetings are appointments that include other people. When you create a meeting, you select attendees and send an email invitation to them. You can reschedule meetings and set up recurring meetings.
- **Events.** An event is an activity that lasts all day. Events do not display as time on the calendar—they appear as banner at the top of the calendar schedule.

All three types of activities can be entered in several ways. You can schedule an appointment from any calendar view.

### Creating an Appointment or Meeting

There are several ways to create an appointment in the ZWC:

- Using the QuickAdd Appointment dialog.
- Using the Appointment Details tab.
- Dragging and dropping a message from the Inbox to the mini-calendar.



A meeting includes other attendees. An appointment is scheduled for yourself only. The steps to create appointments and meetings are the same with the exception of scheduling attendees—this step is not performed for appointments. Therefore, follow the steps in this Participant Guide for both creating appointments and creating meetings.

## Opening the Appointment Details Tab

To use the **Appointment Details** tab to create an appointment:

- On the toolbar, click the arrow on  and select **New Appointment**. This option is available from the **New** menu in any view, except the Preferences view.

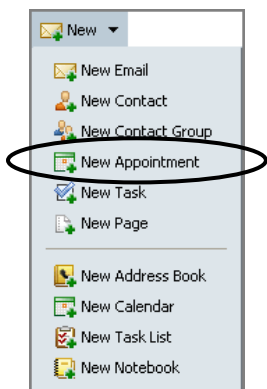

This action opens the **Appointment Details** tab.

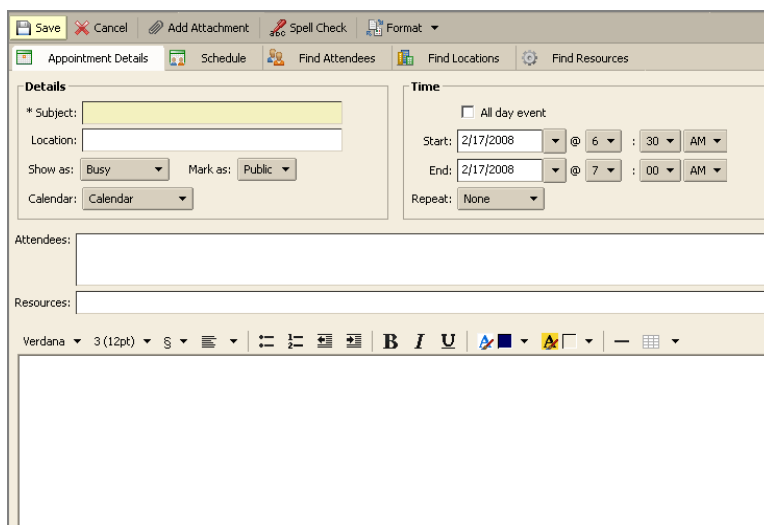

## Opening the QuickAdd Appointment Dialog

The following three methods open the **QuickAdd Appointment** dialog.

- Right-click on either the mini-calendar or the start time in one of the calendar views. You can select to create a **New Appointment** or a **New All Day Appointment**.

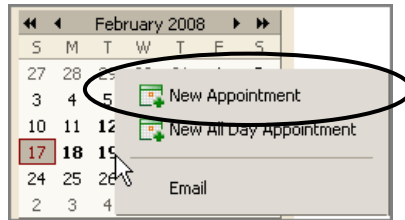

- Within an email message, certain text is interpreted as a date and triggers the ability to right-click to create an appointment. Text such as today, tomorrow, a day of the week, or an exact date are highlighted in messages.
  - Hover the mouse over this type of text to see if you have an appointment scheduled.
  - Click on the highlighted text to open your calendar.

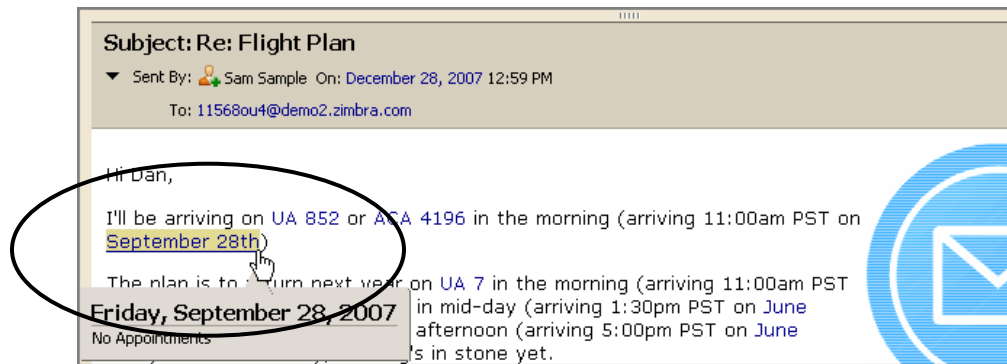

- Enter appointments directly on the calendar. In any calendar view, except Month, either:



- Click on the start time and drag through the end time.

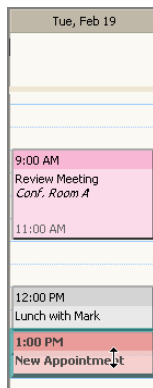

- Double-click the start time.

The QuickAdd Appointment dialog opens.

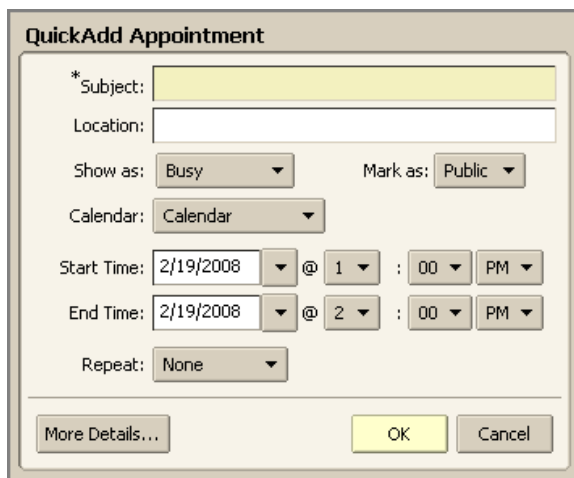

## Creating a QuickAdd Appointment

All of the options previously described open the **QuickAdd Appointment** dialog.



### To create an appointment using the QuickAdd Appointment dialog:

1. Specify the following information:
  - **Subject.** Brief description of the meeting. The text added here becomes the description in the calendar.
  - **Location.** Where is the meeting? If the location is in the company directory, when you start to type, locations that match are listed. You can also go to the **Find Locations** tab to search.
  - **Show As.** Determine your Free/Busy options for this appointment. This information displays on the Schedule Attendees page.

- **Calendar.** Show all calendars in your Calendar List. The first calendar displayed is your original Calendar.

- **Mark as.** Mark an appointment as private or public. Details about events that are marked private do not display in a grantee's shared calendar. Only the start and end time, duration, reoccurrence information, and the organizer's identity are shown in the shared calendar.



- **Start Time and End Time.** Define the start and end day and time.
- **Repeat.** Define how often this appointment occurs.

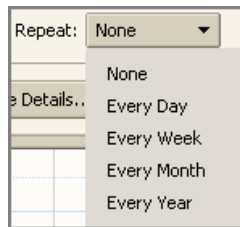

- **More Details.** Opens the **Appointment Details** tab if you want to specify additional appointment information, such as Attendees and Resources. This is optional. Use of the **Appointment Details** tab is described next.

2. Click .

## Creating a Meeting Using the Appointment Details Tab

This section describes how to schedule a meeting using the **Appointment Details** tab, including using the following:

- **Details** area
- **Time** area
- **Find Attendees** tab
- **Schedule** tab
- **Find Locations** tab
- **Find Resources** tab

**To schedule a meeting from the Appointment Details tab:**

1. Click the arrow on  in the toolbar and select **New Appointment**. This option is available from the **New** menu in any view, except the Preferences view.

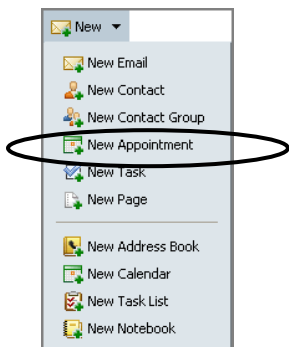

The Appointment Details tab appears.

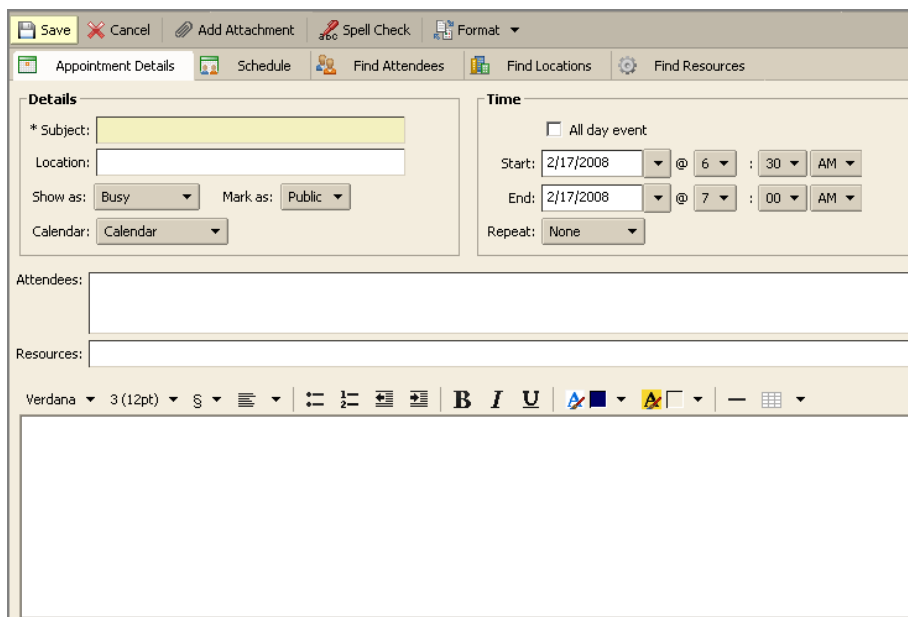

2. Specify the following information in the **Details** area:

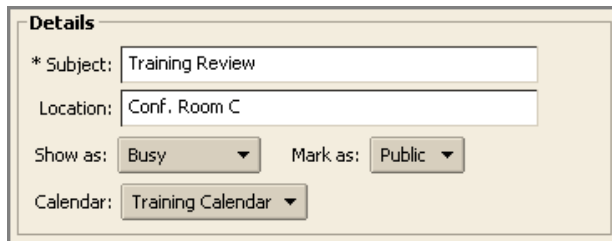

- **Subject.** Brief description of the meeting. The text added here becomes the description in the calendar.
- **Location.** Where is the meeting? Either:
  - Type the location. If the location is in the company directory, when you start to type, locations that match are listed.
  - Go to the **Find Locations** tab. Use of the **Find Locations** tab is described later in this chapter.
- **Show As.** Determine your Free/Busy options for this appointment. This information displays on the Schedule Attendees page.

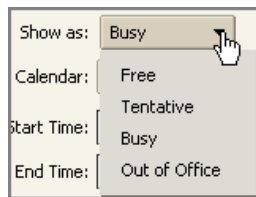

- **Mark as.** Mark an appointment as private or public. Details about events that are marked private do not display in a grantee's shared calendar. Only the start and end time, duration, reoccurrence information, and the organizer's identity are shown in the shared calendar.



- **Calendar.** Show all calendars in your Calendar List. The first calendar displayed is your original Calendar.

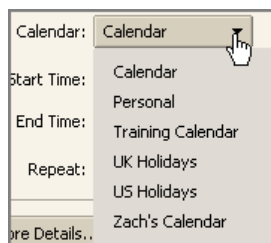

3. Specify the following information in the **Time** area:







The screenshot shows a dialog box titled "Time". At the top, there is a checkbox labeled "All day event". Below this, there are two rows for "Start" and "End". Each row consists of a date field (both set to "2/19/2008"), an "@" symbol, a time field (set to "1" for start and "2" for end), a colon, a minutes field (set to "30" for start and "00" for end), and a PM/AM field (both set to "PM"). At the bottom, there is a "Repeat:" dropdown menu currently set to "None".

- All day event. Select this option to make this appointment an all day event. Events do not display as time on the calendar, they appear as banner at the top of the calendar schedule
- **Start Time** and **End Time**. Define the start and end day and time.
- **Repeat**. Define how often this appointment occurs.

The screenshot shows the "Repeat:" dropdown menu expanded. The options listed are: "None", "Every Day", "Every Week", "Every Month", and "Every Year".

4. Specify the following remaining information:

- **Attendees**. Either:
  - Type the email addresses of your attendees, separating addresses with a semicolon (;). Names in your Contact list matching what you type auto-display as you type.
  - Go to the **Find Attendees** tab. Use of the **Find Attendees** tab is described later in this chapter.
- **Resources**. Either:
  - Type the email addresses of your resources, separating addresses with a semicolon (;). Resource names in your Contact list matching what you type auto-display as you type.
  - Go to the **Find Resources** tab. Use of the **Find Resources** tab is described later in this chapter.

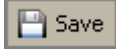
- **Body.** Type an email message that will be included in the appointment invitation email
  - **Options.** Either:
    - Click  in the toolbar to include an attachment in the appointment invitation email.
    - Click  in the toolbar to spell check the appointment invitation email.
5. Click  .

## Scheduling Attendees: The Find Attendees Tab

When creating an appointment from the **Appointment Details** tab, you can use the **Find Attendees** tab to search for attendees using your address books and your company GAL.

**To use the Find Attendees tab:**

1. Click  in the Calendar view. The **Find Attendees** tab appears.

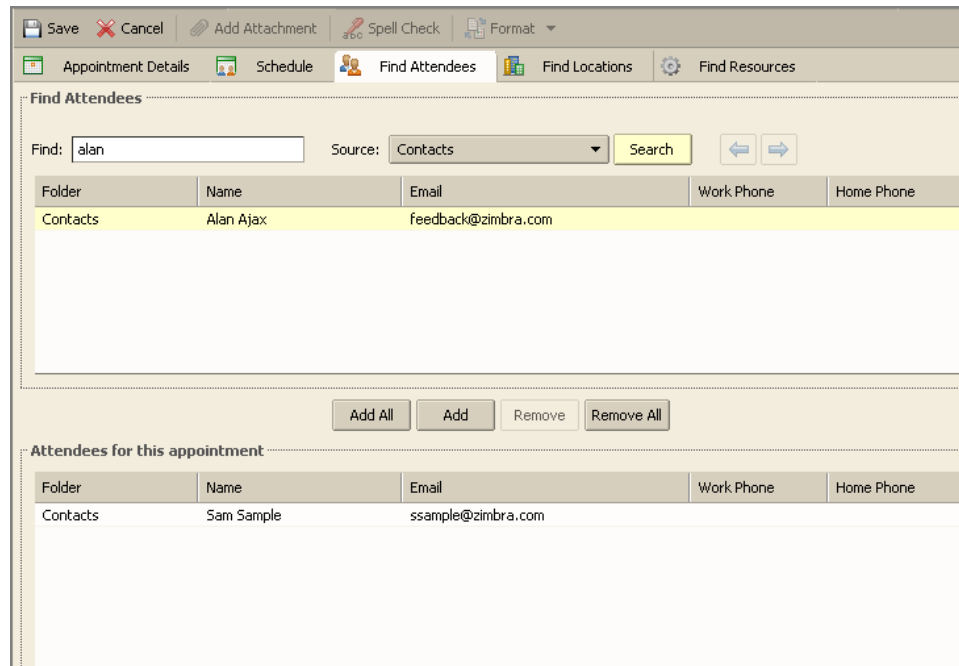

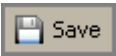

2. Type a name into the **Find** field.
3. Select which list to use from the **Source** drop-down menu. The options will include your address books and the GAL (if your account is linked to a GAL).
4. Click **Search**.
5. Select the name(s) displayed.
6. Click either **Add All** or **Add**. Names are displayed in the **Attendees for this Appointment** area.
7. When complete, click .



## Viewing Free/Busy Times: The Schedule Tab

After selecting your appointment attendees, you can use the **Schedule** tab to see the free/busy schedules for attendees.

### To use the Schedule tab:

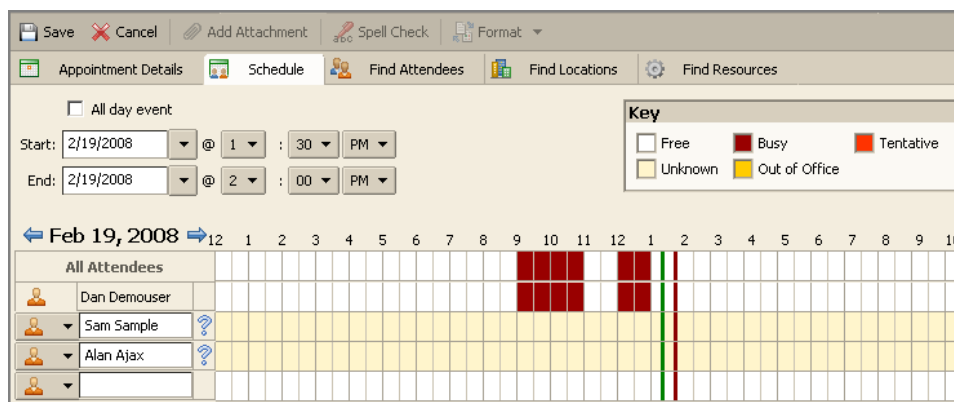
1. Click  in the Calendar view. The **Schedule** tab appears.



2. Use the **Key** area to determine the free/busy time for each attendee.
3. This column identifies the following:
  -  Indicates that an attendee has not accepted the invitation yet.
  -  Indicates a location.

-  Indicates a resource.

## Scheduling a Location: The Find Locations Tab

When creating an appointment from the **Appointment Details** tab, you can use the **Find Locations** tab to search for locations using your address books and the GAL (if the GAL is linked to your Zimbra account).

**To use the Find Locations tab:**

1. Click  in the Calendar view. The **Find Locations** tab appears.

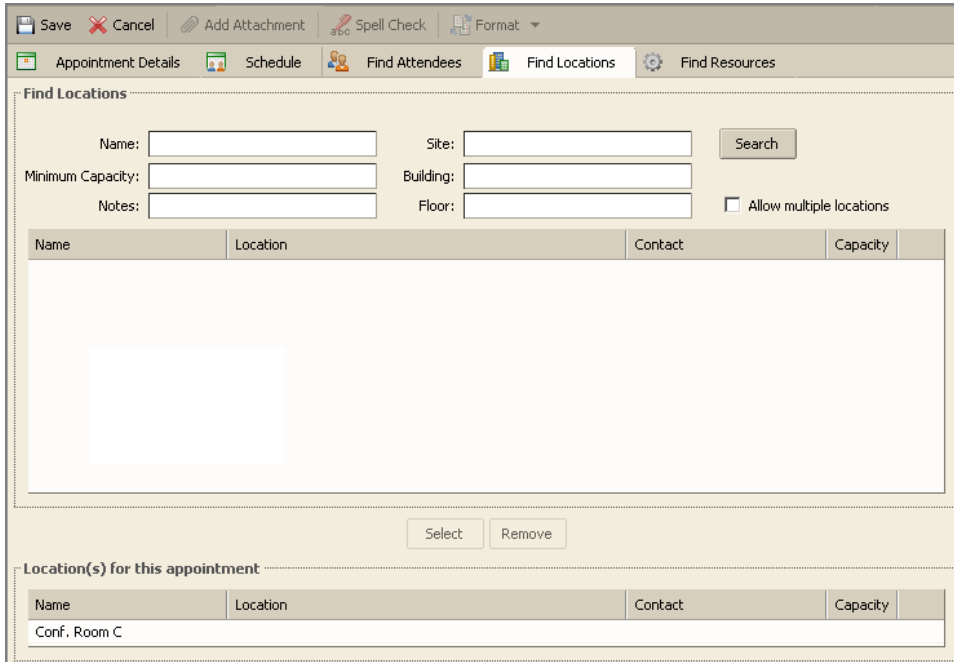

The screenshot shows the 'Find Locations' tab in the Zimbra web client. The interface includes a search form with the following fields: Name, Site, Minimum Capacity, Building, Notes, and Floor. A 'Search' button is located to the right of the Name and Site fields. Below the search form is a table with the following columns: Name, Location, Contact, and Capacity. The table is currently empty. At the bottom of the tab, there are 'Select' and 'Remove' buttons. Below these buttons is a section titled 'Location(s) for this appointment' with a table containing one entry: 'Conf. Room C'.

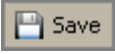
2. Type a search value into one of the fields. For example, type a location name into the **Name** field or type a site name into the **Site** field.
3. Click **Search**. Locations matching your search are displayed.
4. Select a location displayed.
5. Click **Select**. The location appears in the **Location(s) for this appointment** area.
6. When complete, click .



## Scheduling Resources: The Find Resources Tab

When creating an appointment from the **Appointment Details** tab, you can use the **Find Resources** tab to search for resources using your address books and your company GAL. Examples of resources include projectors and other electronic equipment.

### To use the Find Resources tab:

1. Click  in the Calendar view. The **Find Resources** tab appears.

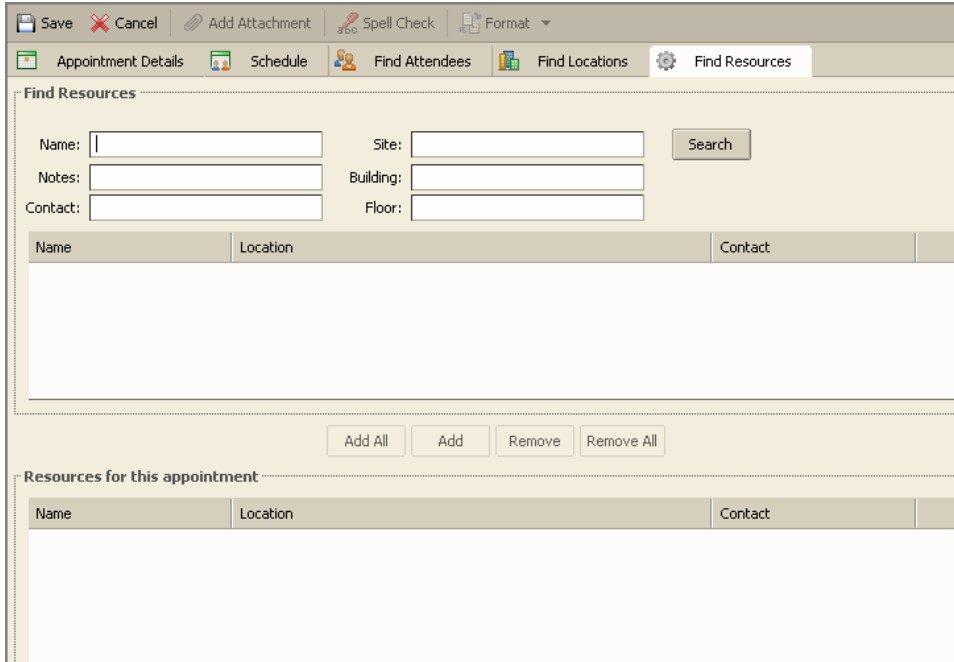

Name	Location	Contact
------	----------	---------

Add All Add Remove Remove All

Name	Location	Contact
------	----------	---------

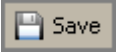
2. Type a search value into one of the fields. For example, type a resource name into the **Name** field or type a site name into the **Site** field.
3. Click **Search**. Resources matching your search are displayed.
4. Select the resource(s) displayed.
5. Click either **Add All** or **Add**. Names are displayed in the **Resources for this Appointment** area.
6. When complete, click .



If you are adding an appointment to a shared calendar, you may need to refresh the screen to see the appointment.

## Scheduling an All Day Event

To schedule an all day appointment, which is called an event in the ZWC, use the **Appointment Details** tab.

**To schedule an all day appointment:**

1. Select the All day event option on the Appointment Details tab.

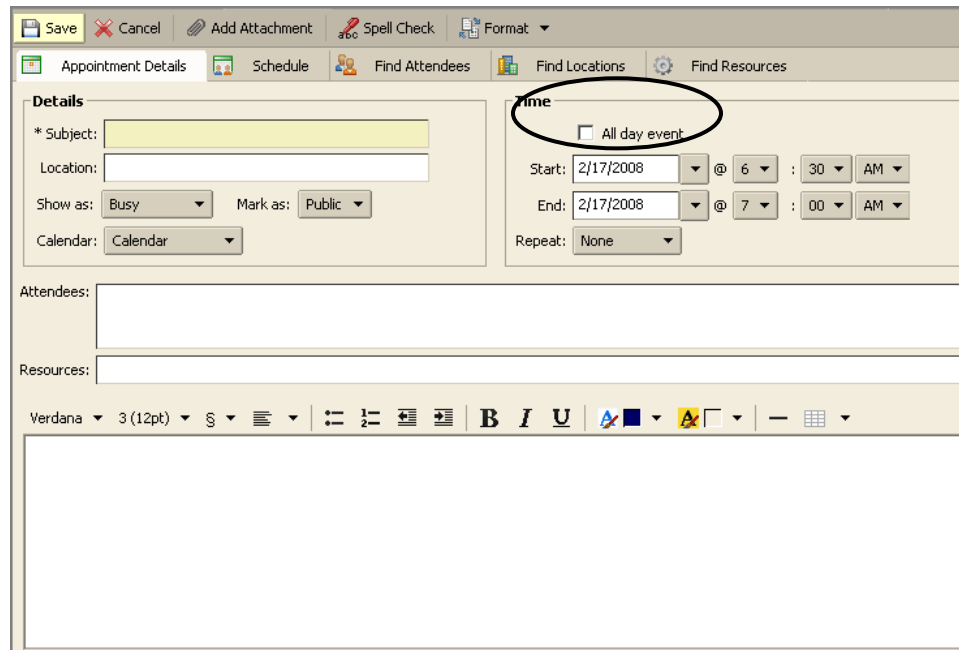

The screenshot shows the 'Appointment Details' dialog box. At the top, there are tabs for 'Appointment Details', 'Schedule', 'Find Attendees', 'Find Locations', and 'Find Resources'. The 'Appointment Details' tab is active. On the right side, under the 'Time' section, the checkbox for 'All day event' is circled. Below it, the start date is '2/17/2008' at '6:30 AM' and the end date is '2/17/2008' at '7:00 AM'. The 'Repeat' dropdown is set to 'None'. On the left side, there are fields for 'Subject', 'Location', 'Show as' (set to 'Busy'), 'Mark as' (set to 'Public'), and 'Calendar' (set to 'Calendar'). There are also empty fields for 'Attendees' and 'Resources'. At the bottom, there is a rich text editor toolbar with options for font face (Verdana), size (12pt), bold, italic, underline, and other formatting options.

If you are using the **QuickAdd Appointment** dialog, click the **More Details** button. This will open the **Appointment Details** tab from which you can select the **All day event** option.



## Creating a Recurring Appointment

Recurring appointments are appointments that repeat on some sort of schedule. You can schedule recurring meetings to repeat daily, weekly, monthly, or yearly. In addition, you can customize recurring appointment schedules.

### To create a recurring appointment:

1. Select an option from the **Repeat** drop-down menu on either the **QuickAdd Appointment** dialog or the **Appointment Details** tab.

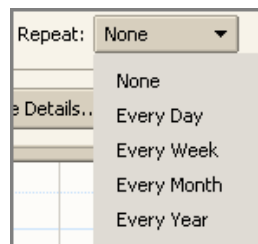

The [Customize](#) link appears.

2. Click [Customize](#) to display the **Custom Repeat** dialog.

**Custom Repeat**

**Repeat**

Weekly ▾

Every Sunday ▾ .

Every 2 weeks on

Sun  Mon  Tue  Wed  Thu  Fri  Sat .

**End**

No end date.

End after 1 occurrence(s).

End by 2/12/2008 ▾ .

OK Cancel

3. Select options from the **Custom Repeat** dialog as necessary.

- **Repeat.** Use this drop-down to specify the frequency of the meeting: daily, weekly, monthly, or yearly. The remaining fields in this dialog change based on the repeat frequency selected.
- **Daily.** Customize daily repeats.

**Repeat**

Daily ▾

Every day.

Every weekday.

Every 2 days.

- **Weekly.** Customize weekly repeats.

**Repeat**

Weekly ▾

Every Sunday ▾ .

Every 2 weeks on

Sun  Mon  Tue  Wed  Thu  Fri  Sat .

- **Monthly.** Customize monthly repeats.

**Repeat**

Monthly ▾

Day 12 of every 1 month(s).

The first ▾ Tuesday ▾ of every 1 month(s).





- o **Yearly.** Customize yearly repeats.

- o **End.** Specify the end date and other information.

4. Click .

## Changing an Appointment or Meeting

You can change any meeting or appointment, including the date, time, attendees, frequency (if repeating), at any time. If you created a recurring meeting, you can change one occurrence or the series of meetings. An email is sent to attendees to update the meeting details.

There are two ways to change an appointment:

1. Double-click on the meeting you want to change.
2. Right-click the meeting you want to change and select **Open**.

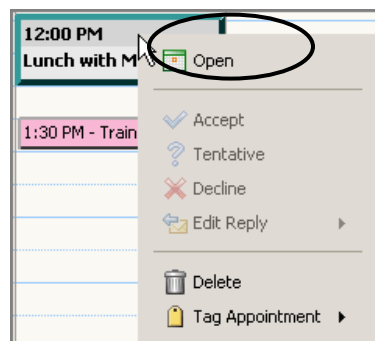

If you are opening a recurring meeting, the **Open Recurring Item** dialog opens.

Use this dialog to either change this single instance of a recurring meeting or to change the entire series.

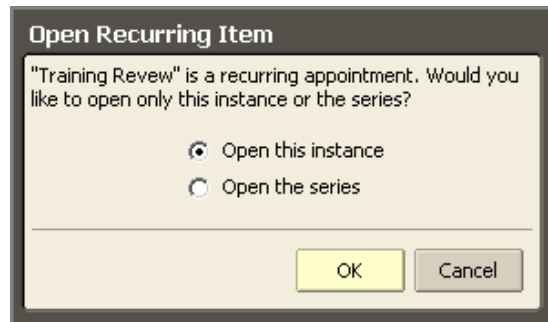

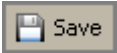
3. The **Appointment Detail** tab appears. Change any information necessary and click .
4. Select whether to open only the selected date or to open the series. The **Appointment** page opens.
5. Make your changes. You can change the schedule, the attendees, add an explanation in the **Text** field and add an attachment.
6. Click **OK**. An email is sent to the attendees.

## Deleting an Appointment or Meeting

If you created a meeting, you can cancel or delete it. If you created a recurring meeting, you can delete one occurrence or the entire series of meetings. An email is sent to attendees to inform them of the cancelled meeting.





Only the originator of an appointment can cancel the appointment. Attendees can cancel the appointment on their own calendars, but attendees cannot cancel the entire appointment.

### Deleting a Meeting

You can delete a meeting in two ways:

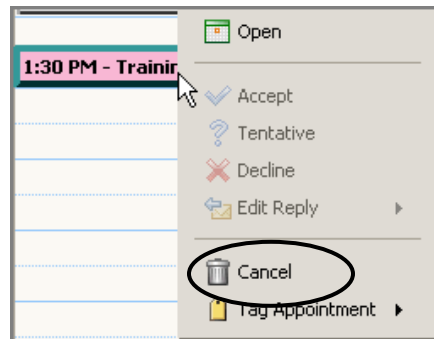
1. Right-click on the meeting in any calendar view and select **Cancel**.



2. Click a meeting in a calendar and click  in the toolbar.

If you are canceling an appointment, a confirmation dialog appears.

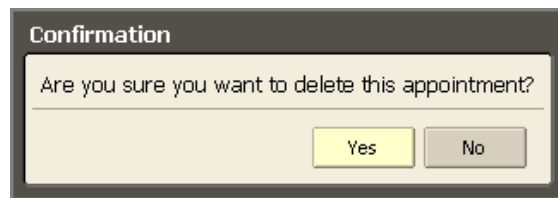

3. Click **Yes** to cancel or delete the appointment. The appointment is immediately removed from your calendar. You cannot undo the delete.

If you are canceling a meeting, a different confirmation dialog appears.

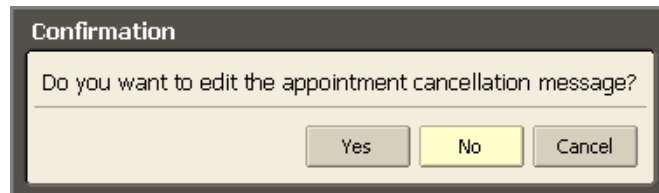

4. Click **Yes** to edit the email sent to attendees. Edit the email as necessary, and click **Send** to send the cancellation message.

The appointment is immediately removed from your calendar. An email is sent to the attendees, and the appointment is deleted from their calendars. You cannot undo a delete.

## Deleting a Recurring Meeting

There are two ways to delete a recurring meeting:

1. Right-click on the meeting in any calendar view, select **Instance** or **Series**, and select **Delete**.

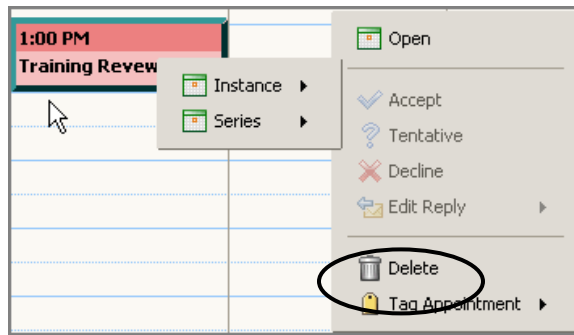

2. Click a meeting in a calendar and click  in the toolbar. A dialog appears where you can specify the instance or the series.



3. Select whether to delete the instance or to delete the series, and click . A confirmation dialog appears.
4. Click **Yes** to delete the meeting instance or series. The appointment is immediately removed from your calendar. An email is sent to the attendees, and the appointment is deleted from their calendars. You cannot undo a delete.

## Printing an Appointment or Meeting

To print appointment and/or meeting information, refer to **Printing a Calendar** in Chapter 8.



## Creating a Meeting Using Drag and Drop: Turning a Message or Contact into a Meeting Request

You can quickly create a meeting request by simply dragging and dropping a message, conversation, or contact to a date on the mini-calendar. When you drag and drop a message or conversation, the information in the message is used to populate many of the fields on the Appointment page.

- The Subject of the appointment is the subject of the message.
- The attendees are the email addresses in the **To** and **Cc** fields of the message or for conversations, the most recent message in a conversation. When you drag a contact from your Contacts list to the mini-calendar, the contact's first email address is added to the attendee field.
- The text of a message or the text of all messages in a conversation thread becomes the text of the invitation. Message attachments are not attached to the appointment request.

### Turning a Message or Conversation into a Meeting Request

**To turn a message or conversation into a meeting request:**

1. Click on a message or conversation and drag it to a date on the mini-calendar.

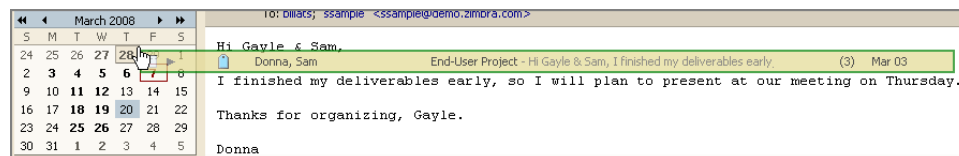

The Appointment Details tab appears.

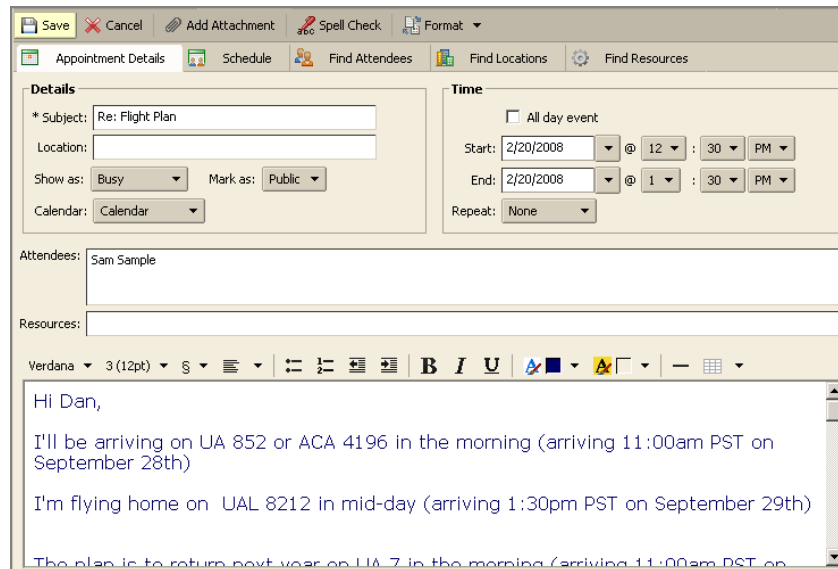

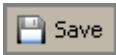
2. Review the meeting request details and make any necessary changes.
3. Click . A meeting invitation is sent to all attendees.

## Turning a Contact into a Meeting Request

**To turn a contact into a meeting request:**

1. Click on a name from your Address Book list and drag the name to a date on the mini-calendar.

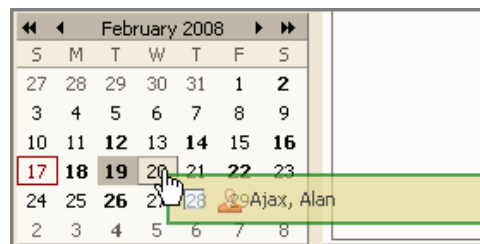

The appointment page opens with the contact name in the Attendees field.

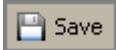

2. Finish the meeting request details: add a subject, select a time, add more attendees, etc.
3. Click . A meeting invitation is sent to the contacts.

## Responding to a Meeting Invitation



When you receive an email notification for a meeting, the meeting is added to your calendar and marked **New**. You can quickly respond to the invitation either from the email **Inbox** or from the **Calendar List** pane.

### To respond to a meeting invitation:

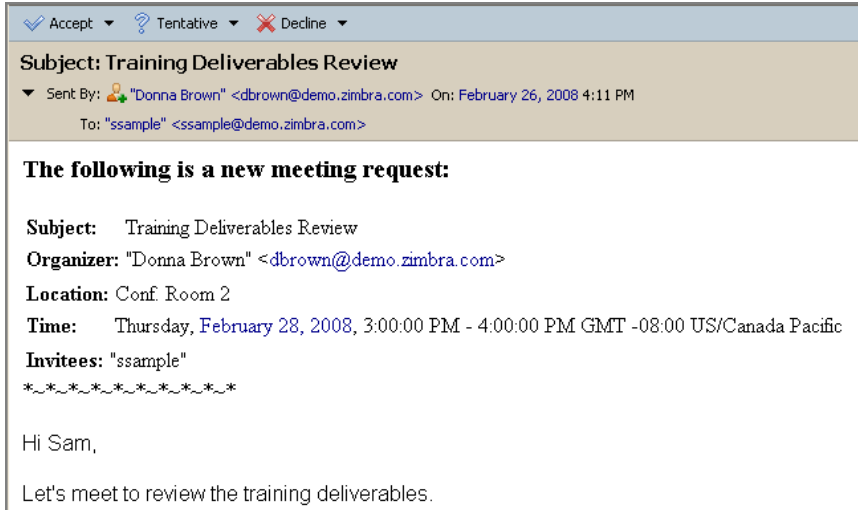
1. Open the message that contains the meeting request by either:
2. Clicking on the invitation email in the **Inbox**.
3. Right-clicking the appointment in the **Calendar List** pane and select **New**. The meeting invitation appears.



4. Select an action. There are three actions:

-  Accept Accepts the meeting.
-  Tentative Shows the meeting in orange in your calendar.
-  Decline Removes the meeting from your calendar.

5. Click any of these actions to automatically send a reply to the meeting organizer indicating your response, either I will attend; I might attend, or No, I won't attend.

6. Click the arrow on the action and select **Edit Reply** to add comments to the reply email. This is optional.

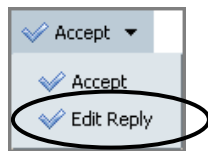

If the meeting is a recurring meeting, you have the option to reply for an **Instance** or the **Series**.

To add comments when responding to a meeting invitation in Calendar List pane, right-click the appointment and select **Edit Reply**.



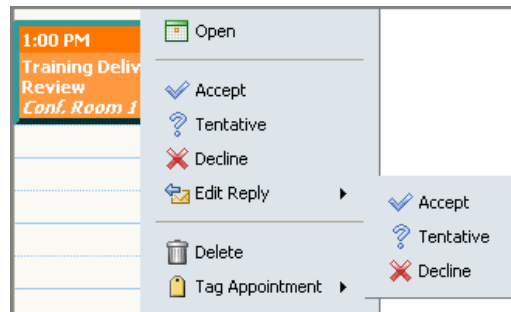

After you make your choice, the invitation is moved to the Trash, and **New** is removed from the calendar notice. Declined appointments display on your calendar in a faded view, as a reminder of the meeting you declined. You can delete declined message any time.



If you would prefer to have the invitation email remain in your Inbox, change this preference on the **Preference > Calendar** tab.

To read the message or to see any attachments that may have been sent, click the meeting notice.

## Changing Your Response to a Meeting Invitation

If you decide to change your response to a meeting invitation, for example, if you want to accept a previously declined meeting:

1. Right-click the meeting in your calendar.
2. Select **Accept** from the menu.

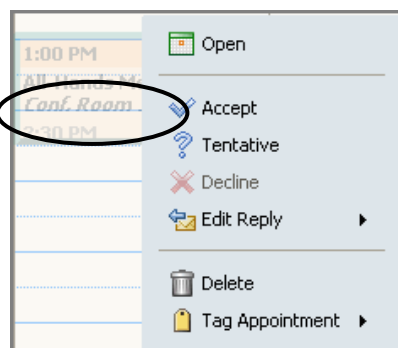

An automatic response is sent to the meeting organizer to indicate that you have accepted the meeting.



## 10 Using the Preferences Tabs

---

This chapter provides a high-level overview of the features of each tab. You can do such things as:

- Create away messages using the Mail tab
- Create email signatures using the Signatures tab
- Create additional email personas and link to external email accounts using the Accounts tab



The key functionality for each of these tabs is covered in detail in other chapters of this user guide. This chapter provides a high-level overview of the features of each tab.

Your default user preferences are configured when your account is created. These options define how your mailbox, address books, and calendar work. You can also set up your personal email identities and POP accounts and select a theme for your mailbox.

You can change the default settings using the **Preferences** tabs. If an option described here is not visible in your view, it is not available for your account.

### Saving, Canceling, and Reverting Changes to Preferences

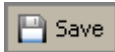
There are three things you can do on each **Preferences** tab:

- Click  in the toolbar to save any changes you made on the tab. This saves your changes and returns you to your ZWC view.
- Click  in the toolbar to cancel any changes you made on the tab. This cancels your changes and returns you to your ZWC view.
- Click  in the top right corner of any Preferences tab to reset any changes for that page to your last saved settings.

This revert feature does not affect changes to passwords.

You can navigate to different **Preferences** tabs, making changes on multiple tabs, before you

click  or  .

## General Tab

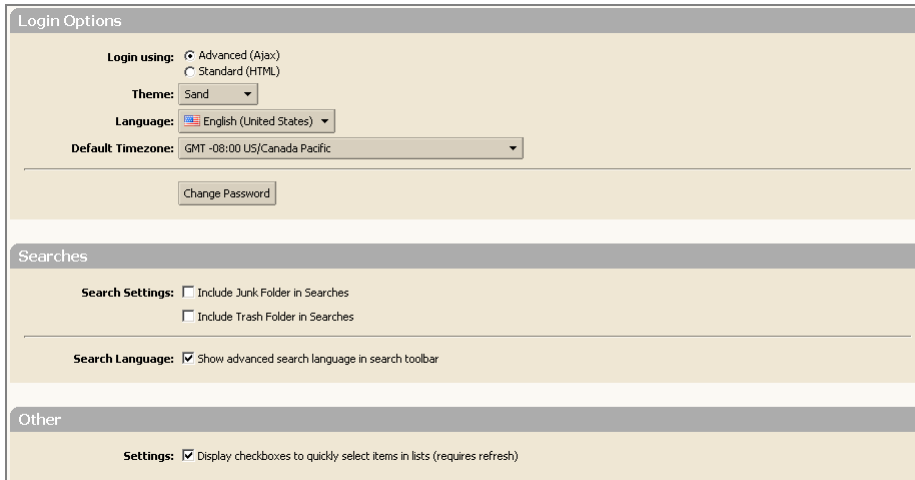

The screenshot shows the 'General' tab of the Zimbra Web Client Preferences. It is divided into three sections: 'Login Options', 'Searches', and 'Other'. In the 'Login Options' section, 'Login using' has radio buttons for 'Advanced (Ajax)' (selected) and 'Standard (HTML)'. 'Theme' is a dropdown menu set to 'Sand'. 'Language' is a dropdown menu set to 'English (United States)'. 'Default Timezone' is a dropdown menu set to 'GMT-08:00 US/Canada Pacific'. A 'Change Password' button is located below these options. The 'Searches' section contains two checkboxes: 'Include Junk Folder in Searches' (unchecked) and 'Include Trash Folder in Searches' (unchecked). The 'Search Language' checkbox is checked, with the text 'Show advanced search language in search toolbar'. The 'Other' section contains one checkbox: 'Settings: Display checkboxes to quickly select items in lists (requires refresh)' (checked).

Use the options on the **Preferences > General** tab as follows:

- **Login using.** Defines your default **Client Type** at log in.
- **Advanced.** Offers the full set of Web collaboration features. This Web Client works best with newer browsers and faster Internet connections.
- **Standard.** Recommended when Internet connections are slow, when using older browsers, or for easier accessibility.
- **Theme.** The background color for your mailbox interface.
- **Language.** The language used to display the text in the ZWC.
- **Default Time zone.** The default time zone for your account. This determines the date and time for messages that you send or receive and the time to display for Calendar appointments. This can be different from your computer time zone configuration.
- **Change password.** Used to change your password. If you have trouble changing your password, or if this button is not displayed, contact your administrator for password help.

- **Search Settings.** Check **Include Junk Folder in Searches** and/or **Include Trash Folder in Searches** to include these folders in any search you perform. By default these folders are not searched.
- **Search Language.** Check **Show advanced search language in search toolbar** to show search string details in the search text box at the top of the ZWC window.
- **Settings.** Check **Display checkboxes to quickly select items in lists (requires refresh)** to display a checkbox for each item in the Content pane. When this is enabled, use the checkbox to select one or more items to perform the same action on, such as delete, move, or mark as read/unread.

## Mail Tab

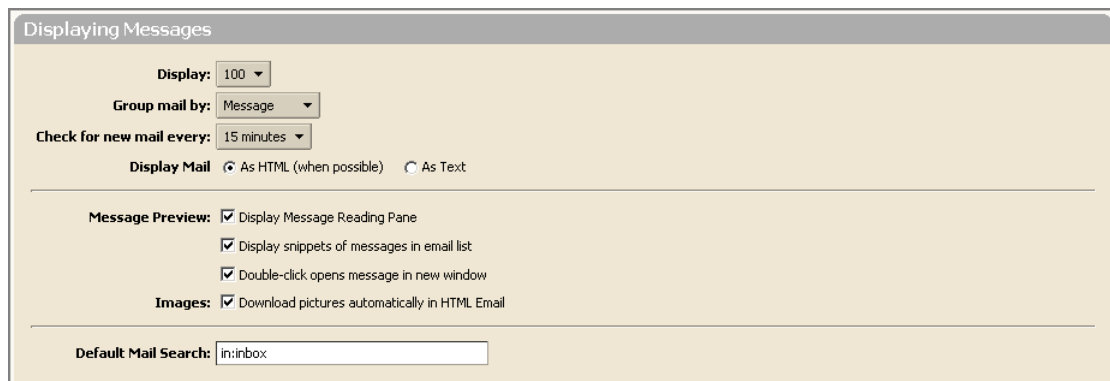

**Displaying Messages**

Display: 100

Group mail by: Message

Check for new mail every: 15 minutes

Display Mail  As HTML (when possible)  As Text

---

**Message Preview:**  Display Message Reading Pane  
 Display snippets of messages in email list  
 Double-click opens message in new window

**Images:**  Download pictures automatically in HTML Email

---

Default Mail Search:

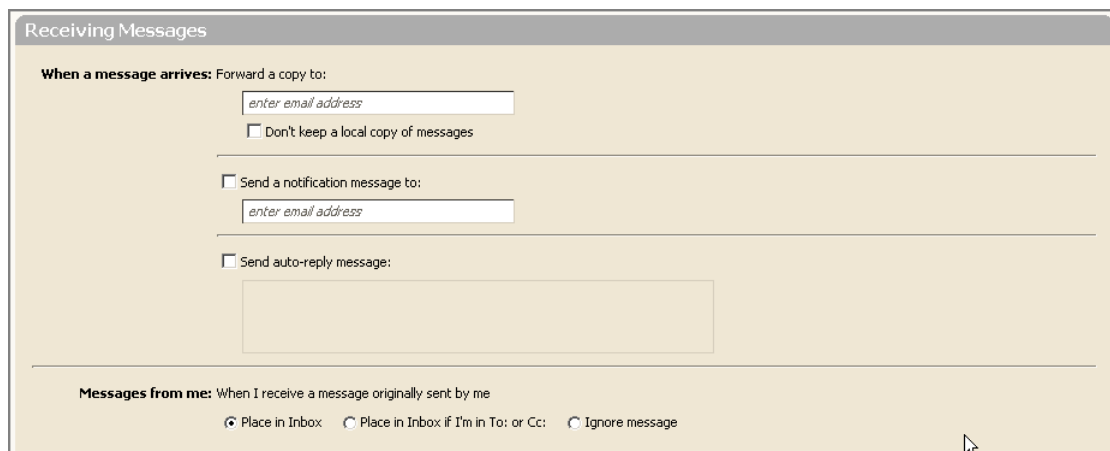

**Receiving Messages**

**When a message arrives:** Forward a copy to:  
  
 Don't keep a local copy of messages

---

Send a notification message to:

---

Send auto-reply message:

---

**Messages from me:** When I receive a message originally sent by me  
 Place in Inbox  Place in Inbox if I'm in To: or Cc:  Ignore message



Setting an auto-reply message, also known as an away message, is a common task performed by Zimbra end-users. This task is performed using the **Mail** tab. For steps on creating an auto-reply message, refer to Chapter 6.

Use the options on the **Preferences > Mail** tab as follows:

- **Display.** Select how many items (messages or conversations) to display per page. The default is to display 25 items per page, but you can select 10, 50, or 100 items per page.
- **Group mail by.** Select how you want to group your email, by conversation or message. If you have the Conversation feature, Conversations is the default.
- **Check for new mail every.** Select the polling interval, which is how often your computer checks for new email. The default is every 5 minutes. The minimum length of time is defined by your administrator.
- **Display Mail.** Select **As HTML (when possible)** to display messages with HTML formatting, for example, with bold, colored, or otherwise styled text. Select **As Text** to display messages in plain text format. In plain text format, HTML tags are displayed, not applied as markup.
- Message Preview options:
  - Select whether to show the Reading pane when viewing messages. The default is to always show the Reading pane.
  - Select whether to display snippets of messages in email list. When on, the first line in the email is displayed when the cursor is over the subject of a message. When off, only the first few words of the message are displayed.
  - Select whether a double-click will open messages in a new window.
- **Images.** Select whether to download pictures automatically to your HTML email message.
- **Default Mail Search.** Defines the search to execute when you log in. The results of this search are displayed in the Content pane when you log into your mailbox. The default search is your Inbox. Therefore, when you log in, the results of your Inbox display. You can change this field to have another folder, tag, or a saved search displayed when you first open the Zimbra Web Client.



- **When a message arrives: Forward a copy to.** Specify an address to which you want to forward your email. Select the checkbox if you do not want to keep a copy of the forwarded message in your mailbox.
  - **Send a notification message to.** Specify an address where you want to be notified of new email in your ZWC mailbox.
  - **Send auto-reply message.** Use this to send an away message saying that you are out of the office. Specify the text for the message using the field provided. Set the Start and Stop dates for which this auto-reply message should be used.
- **Messages from me.** Use this section to handle messages you send that include your address as one of the recipients of the message or that are included in an address, such as a mailing list, that includes you.

## Composing Messages Tab

Composing Messages

**Compose:**  As HTML  As Text  
Font: Verdana Size: 12pt Color: [Color Picker]

Always compose in new window  
 Automatically save drafts of messages while you are composing

**Reply / Reply All:** When replying to an email:  
Include original message

**Forward:** When forwarding an email:  
Include original message

**Prefix:** Prefix included messages with:  
 >  |

**Sent Messages:**  Save a copy to Sent folder  
 Do not save sent messages

Additional composing options can be set on the [Accounts Page](#)

Use the options on the **Preferences > Composing** tab as follows:

- **Compose.** Select your default text editor, either HTML or plain text.

Set the default font settings to be used when using HTML to compose in Email, Documents, and Calendar. You can define the font style, size, and color to use as your default style. Verdana, 12 point black is the default.



- **Always compose in new window.** When selected, a new compose window opens, separate from your mailbox, when you compose a message. You can view and navigate your mailbox while the compose window is open.
- **Automatically save drafts of messages while you are composing.** When selected, drafts of messages are saved every few minutes. If you prefer not to have messages automatically saved, disable the feature.
- **Reply / Reply All.** Select whether to include the original text in the body of your reply message. You can choose:
  - Include original message
  - Don't include original message
  - Include original message with the prefix below (either > or | )
  - Include original message as an attachment
  - Include last message only. Includes only what was written by the person who sent the last message, and not previous text
- **Forward.** Select whether to include the original text in the body of a forwarded message. You can choose:
  - Include original message
  - Include original message with the prefix below (either > or | )
  - Include original message as an attachment
- **Prefix.** Specify whether to prefix each line with > or | for email messages that are forwarded or replied to, if you chose to include the original message text.
- **Sent Messages.** Specify whether or not to save a copy of sent messages in the Sent folder. By default, the **Save copies of messages to sent folder** is enabled.



## Signatures Tab

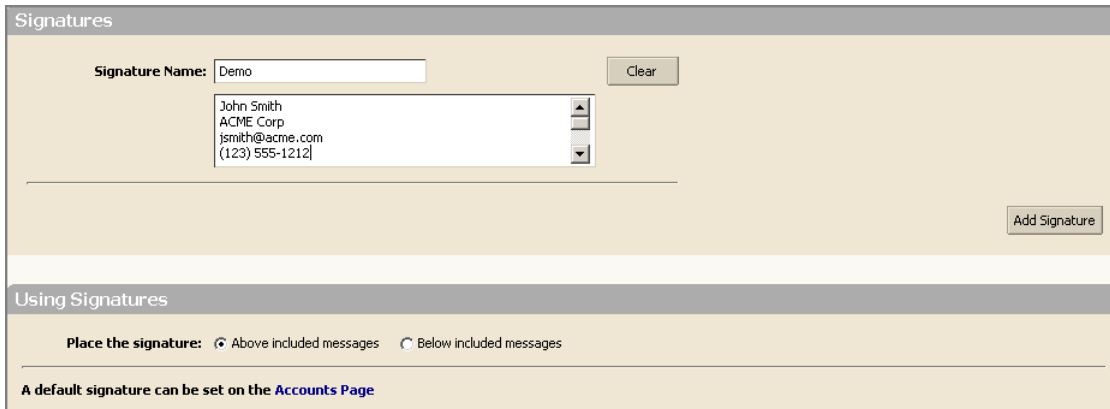

Signatures

Signature Name: Demo

John Smith  
ACME Corp  
jsmith@acme.com  
(123) 555-1212

Using Signatures

Place the signature:  Above included messages  Below included messages

A default signature can be set on the [Accounts Page](#)

You can create signatures for your email messages. This is a task commonly performed by end-users. For detailed steps on creating an email signature, refer to Chapter 3.

Your signature can include your name and additional closing text to the maximum number of characters that your account allows. If you create multiple identities, you can create different signatures and assign them to specific addresses.

Type a name that identifies the signature into the **Signature Name** field. You can create multiple signatures, so using an identifiable name here is important.

1. Type the signature text into the text box exactly as you want it to appear.
2. Specify in the **Using Signatures** section where you want your signature displayed.
3. Select **Above included messages** to add your signature at the end of the your composed, replied to, or forwarded text.
4. Select **Below included** messages to add the signature at the end of the message.
5. Click **Add Signature**.



## Address Book Tab

The screenshot shows the 'Options' and 'Import / Export' sections of the Zimbra Address Book interface. The 'Options' section includes a dropdown for 'Display contacts per page' set to 25, a dropdown for 'Default View' set to List, and two checkboxes under 'Settings': 'Add new contacts to "Emailed Contacts"' (checked) and 'Auto-complete includes addresses in the Global Address List' (unchecked). The 'Import / Export' section contains instructions for importing contacts from a CSV file, with a text input for the 'CSV File', a 'Browse...' button, and an 'Import .CSV File' button. Below this, it provides instructions for exporting contacts to a CSV file, with an 'Export as .CSV File' button.

Use the options on the **Preferences > Address Book** tab as follows:

- **Display contacts per page.** Select how many contacts to display per page. The default is to display 25 contacts per page, but you can select 10, 50, or 100 items per page.
- **Default View.** Choose to display contacts either in a list view or in business card view.
- **Settings.** Select **Add new contacts to "Emailed Contacts"** to automatically add addresses to your address book when you send email. If this is enabled, addresses are saved to your Email Contacts folder.
- **Import / Export.** Import contacts to and export contacts from your ZWC Contacts list. The file to import must be in a comma-delimited format.

## Accounts Tab

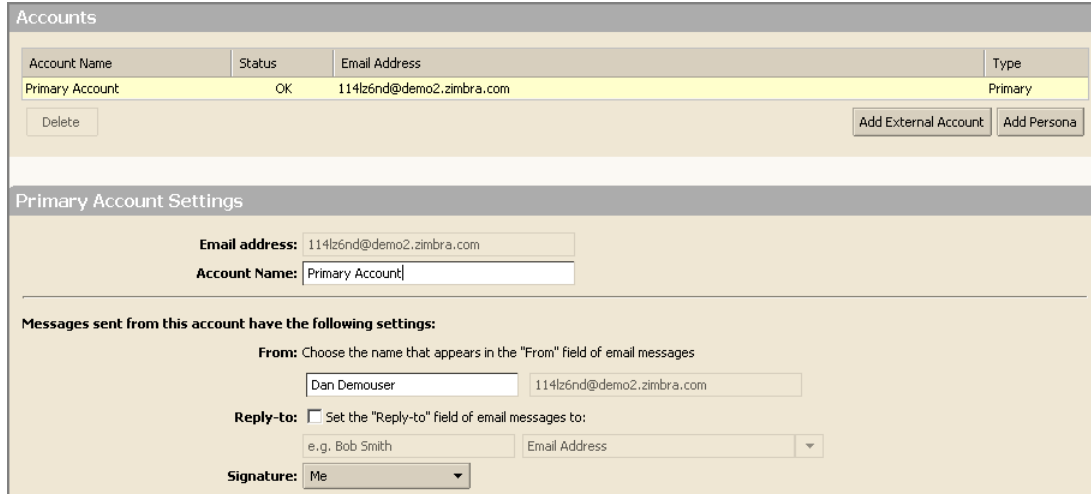

Account Name	Status	Email Address	Type
Primary Account	OK	114lz6nd@demo2.zimbra.com	Primary

Primary Account Settings

Email address: 114lz6nd@demo2.zimbra.com  
Account Name: Primary Account

Messages sent from this account have the following settings:

From: Choose the name that appears in the "From" field of email messages  
Dan Demouser 114lz6nd@demo2.zimbra.com

Reply-to:  Set the "Reply-to" field of email messages to:  
e.g. Bob Smith Email Address

Signature: Me

The **Accounts** tab is used to create and manage your personas and external email accounts. Persona is the email identity used in the **From** field of email messages you send.

Adding external accounts and personas are tasks commonly performed by Zimbra end-users. For detailed steps on these tasks, refer to Chapter 6.

## Mail Filters Tab

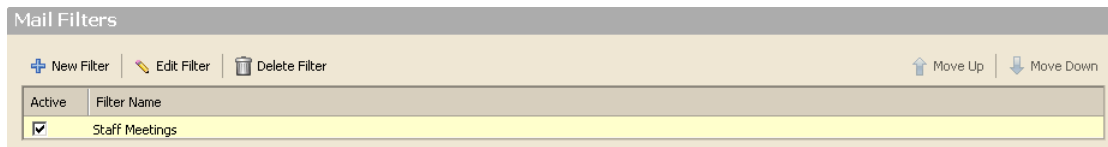

Mail Filters

New Filter Edit Filter Delete Filter Move Up Move Down

Active	Filter Name
<input checked="" type="checkbox"/>	Staff Meetings

Use the **Mail Filters** tab to define email filtering rules.

Refer to Chapter 5 for further information on creating and using filters.

## Calendar Tab

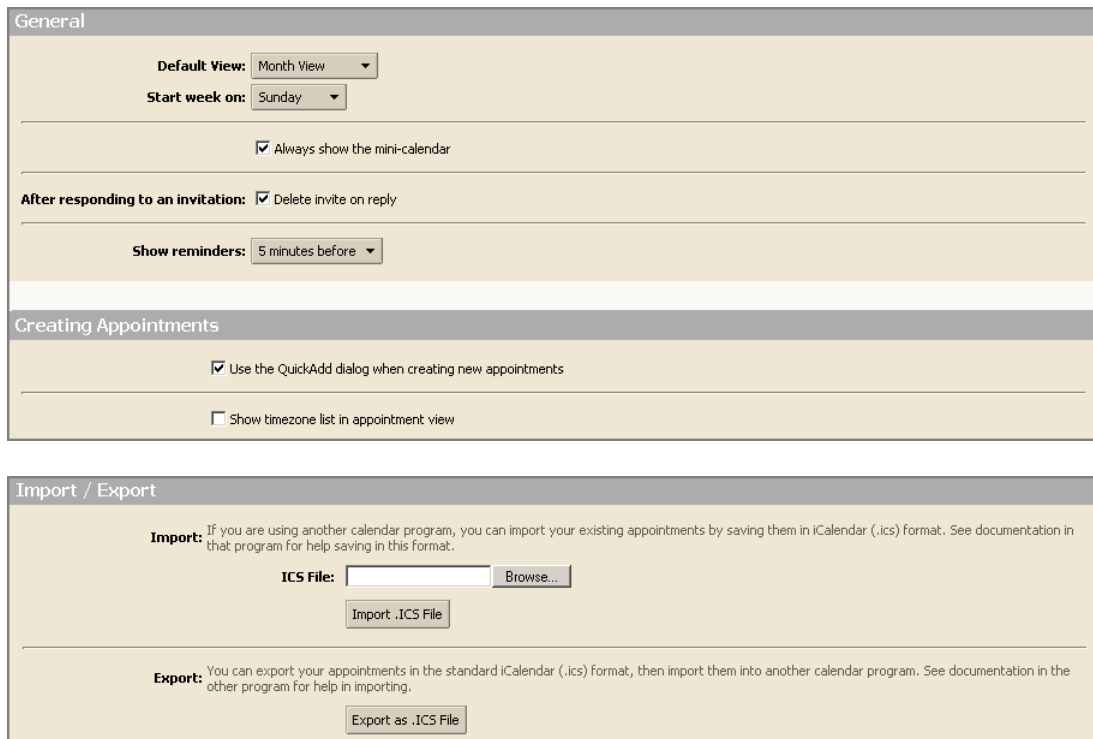

The screenshot displays the Zimbra Calendar preferences interface, organized into three main sections:

- General:** Contains settings for the default view (Month View), start week on (Sunday), a checkbox for "Always show the mini-calendar", a checkbox for "Delete invite on reply" under "After responding to an invitation", and a dropdown for "Show reminders" (5 minutes before).
- Creating Appointments:** Contains a checkbox for "Use the QuickAdd dialog when creating new appointments" and a checkbox for "Show timezone list in appointment view".
- Import / Export:** Contains instructions for importing and exporting appointments in iCalendar (.ics) format. It includes a text input for "ICS File" with a "Browse..." button, an "Import .ICS File" button, and an "Export as .ICS File" button.

Use the options on the **Preferences > Calendar** tab as follows:

- **Default View.** Select how you would like to view your Zimbra calendar. The default is by work week. The view options include: Day, Work Week, 7 Day Week, Month, and Schedule.
- **Start Week On.** Specify which day of the week should be the first day of the week in your calendar.
- **Always show the mini-calendar.** Specify whether the mini-calendar is displayed at the bottom of the Overview pane.
- **After responding to an invitation.** Specify whether to automatically delete invitations from your Inbox after you respond to them.
- **Show reminders.** Set the number of minutes before an appointment to be reminded. The default is five minutes.

- **Use the QuickAdd dialog when creating new appointments.** Specify whether to create new appointments using the **QuickAdd** dialog. This is often helpful if you create many appointments without attendees.
- **Show time zone list in appointment view.** Select if you often schedule meetings with other in different time zones.
- **Import/Export.** Import and export iCalendars.

## Shortcuts Tab

Keyboard Shortcuts			
Shortcut List	Mail Folder Shortcuts	Saved Search Shortcuts	Tag Shortcuts
<b>Shortcuts for All Applications</b>			
	<b>g</b> <b>m</b>		Switch ("go") to Mail
	<b>g</b> <b>a</b>		Switch to Contacts ("address book")
	<b>g</b> <b>c</b>		Switch to Calendar
	<b>g</b> <b>t</b>		Switch to Tasks
	<b>g</b> <b>i</b>		Switch to Chat ("instant messaging")
	<b>g</b> <b>o</b>		Switch to Options
	<b>g</b> <b>d</b>		Switch to Documents ("notebook")
	<b>n</b>		Create a new item (within the current application)
	<b>n</b> <b>m</b> or <b>c</b>		New message ("compose")
	<b>C</b>		New message in a new window

Keyboard shortcuts let you use the application without going to the mouse. A large number of shortcuts are available. You can also create custom shortcuts by assigning numeric aliases to folders, tags, and saved searches.

- **Shortcut List.** Shows all the existing keyboard shortcuts.
- **Mail Folder Shortcuts.** Used to create a shortcut to quickly go to your email folders and to move a message to that folder. You select the folder and assign a number to it. For example, if you assign 3 to the Inbox folder: From anywhere in your mailbox, typing **v3** will move you to the Inbox. Selecting an item and typing **.3**, will move the item to the Inbox.



- **Saved Search Shortcuts.** Used to create shortcuts to quickly access Saved Searches. Select a saved search and assign a number to it. For example, if you assign 3 to your favorite search, then from anywhere in your mailbox, you can type **s3** to run that search.
- The **Tag Shortcuts** tab is used to create shortcuts to quickly access all items with a specific tag or apply a tag to a message or contact. You select a tag and assign a number to it. For example, a tag called **Follow up** is assigned 3. From anywhere in your mailbox, you can type **y3** to see all items marked with **Follow up**. Select an item and type **t3** to tag that item with **Follow up**.

You can assign any number, but it cannot be repeated within a **Shortcut** tab.

## 11 Using Task Lists

---

This chapter explains how to...



- Create a new task list
- Manage your tasks and task lists

You can use your task lists to create and track the progress of a task. In addition, you can write notes within your task and attach files for easy access from within the task. Having all the relevant information with your task is useful when you share your task list with others.

For simple task all you may need to do is create a task from the Content pane. If a task needs to be managed, you can add more details, define a start and due date, set the priority to the

### Creating a New Task List

There are two ways to create a new task list:

1. Click the arrow on  in the toolbar and select **New Task List**. This option is available from the **New** menu in any view, except the Preferences view.
2. Click on  above the Task List display.



Using either method, the **Create New Task List** dialog appears.

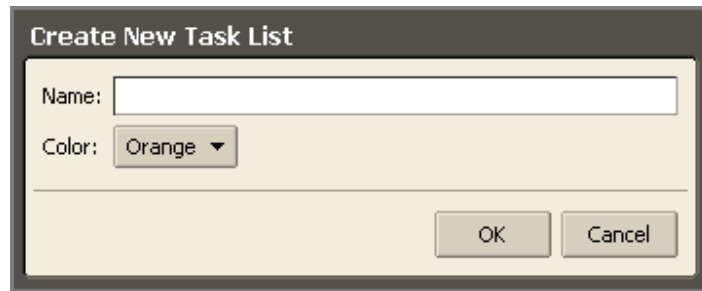

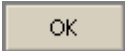

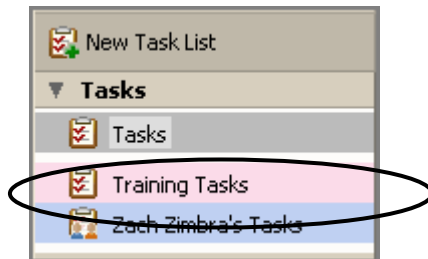
3. Enter a name for the task list in the **Name** field.
4. Select a color for the tasks on this task list.
5. Click . The task list is displayed in the task list display. In the example below, the new task list is **Training Tasks**, which is pink.

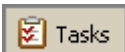

## Creating a New Task

There are two ways to create a task:

1. Click  on the toolbar and click .
2. Click the arrow on  in the toolbar and select **New Task**. This option is available from the **New** menu in any view, except the Preferences view.



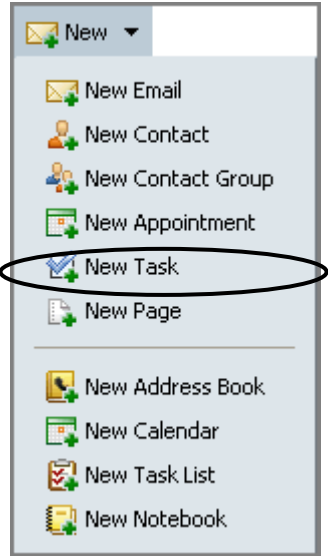

The **Tasks Details** tab appears.

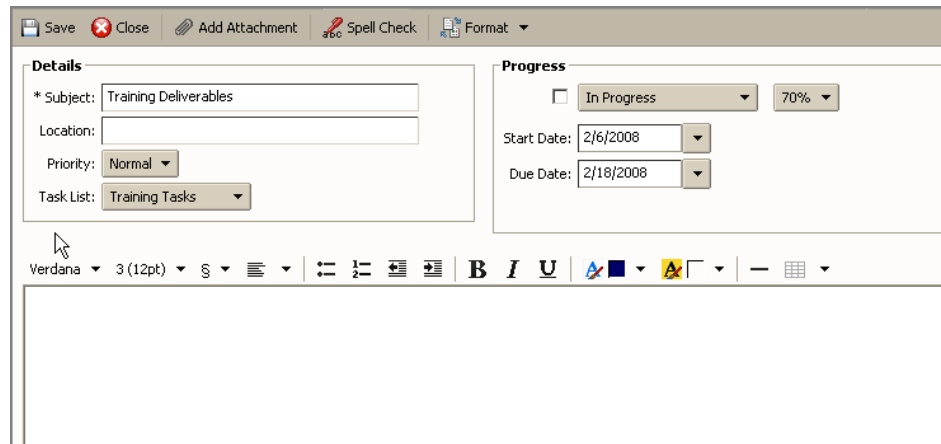

3. Specify the following information in the **Details** area:

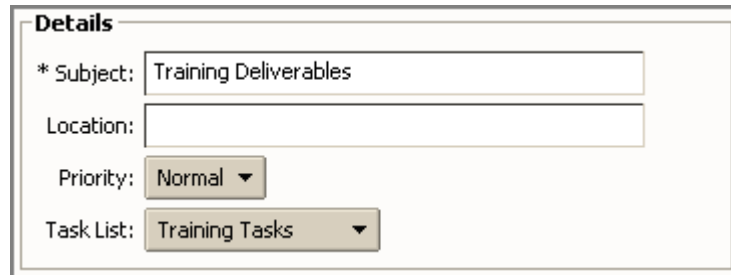

- **Subject.** Brief description of the task. The text added here becomes the description in the task list.

- **Location.** Where does the task occur, if applicable?
- **Priority.** Select the priority for this task.

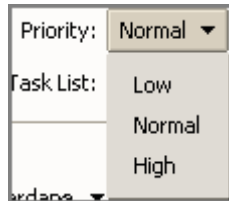

A screenshot of two dropdown menus. The top one is labeled 'Priority:' and has 'Normal' selected. The bottom one is labeled 'Task List:' and has 'Normal' selected. A third dropdown menu is partially visible below it with 'Normal' selected.

- **Task List.** Select the task list where you want this task displayed.

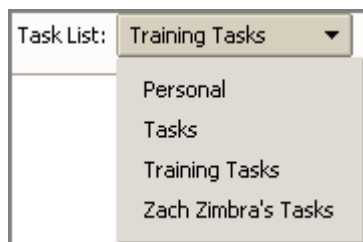

A screenshot of a 'Task List:' dropdown menu. The menu is open, showing options: 'Training Tasks' (selected), 'Personal Tasks', 'Training Tasks', and 'Zach Zimbra's Tasks'.

Specify the following information in the **Progress** area:

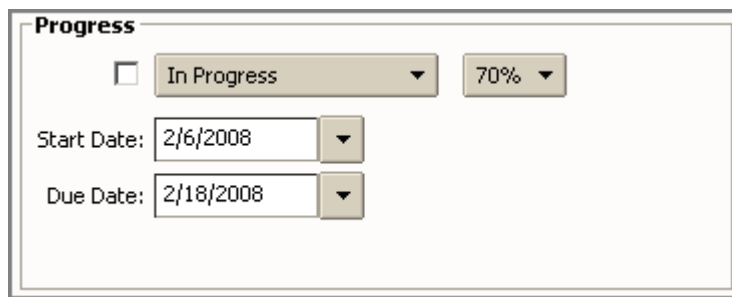

A screenshot of a 'Progress' section. It contains a checkbox labeled 'In Progress' which is checked, followed by a dropdown menu showing '70%'. Below this are two date fields: 'Start Date:' with '2/6/2008' and 'Due Date:' with '2/18/2008', each with a dropdown arrow.

- **Status.** Select the status for this task. You can reopen this task and change this status at any time.

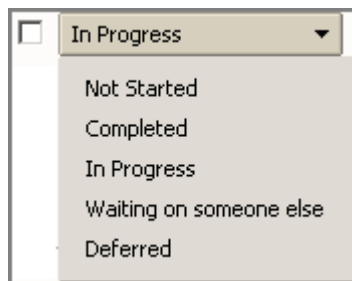



A screenshot of a status dropdown menu. The menu is open, showing options: 'In Progress' (selected), 'Not Started', 'Completed', 'In Progress', 'Waiting on someone else', and 'Deferred'.

- **Percentage.** Select a percentage to go with the status of the task. You can reopen this task and change this percentage at any time.

4. Define the start and end day and time for the task.
5. Specify the following remaining information:
  - o **Body.** Type any notes to be included in the task list.

Options:

- Click  in the toolbar to include an attachment for the task.
- Click  in the toolbar to spell check the task body.
- Click .

## Adding a Task Quickly

**To quickly add a new task to a task list:**

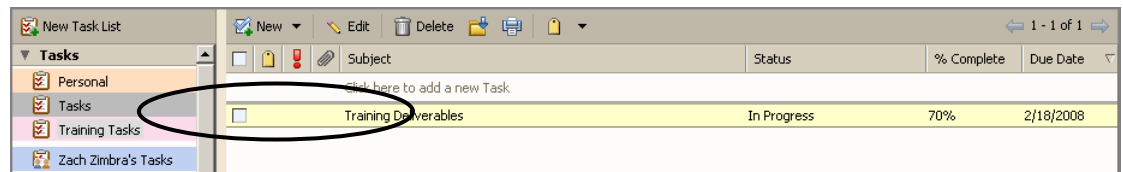

1. Open the task list to which you want to add a task. Double-click on the task list in the **Tasks** area of the Overview pane to open a task list.



2. Click [Click here to add a new task.](#)
3. Type a name for the new task and press **Enter**.

This adds the task subject to your task list, but it does not give any details. To add details, edit the task.

There are two ways to edit the task information:

- Double-click the task.
- Click the task and click  in the toolbar. The **Task Details** tab appears. Edit the information displayed and click .

If you add or create a task in the wrong task list, either:



- Open the task, and select the correct task list from the **Task Lists** drop-down.
- Drag and drop the task on the Content pane to the correct task list in the Overview pane.



You can use Zimbra Assistant to quickly add a task while working within an email message, a meeting within calendar, or viewing a contact. When the task is created, any of the information that was available is added to the Task text area. For more information on Zimbra Assistant, refer to Chapter 1.

## Changing or Updating a Task

As you progress on a task, you may want to change its status and % complete information.

### To update a task:

1. Open the task list you want to update. Double-click on the task list in the **Tasks** area of the Overview pane to open a task list.

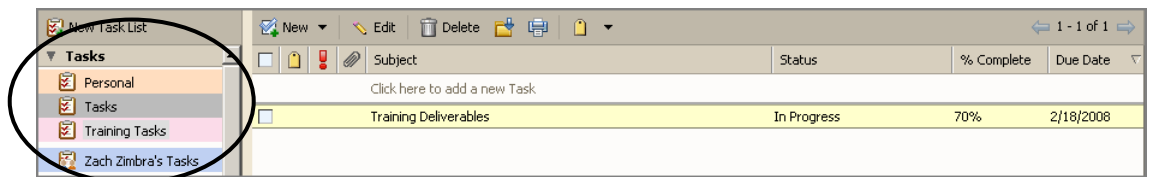

2. Edit the task information using one of these two methods:
3. Double-click the task.
4. Click the task and click  in the toolbar.

The Task Details tab appears.

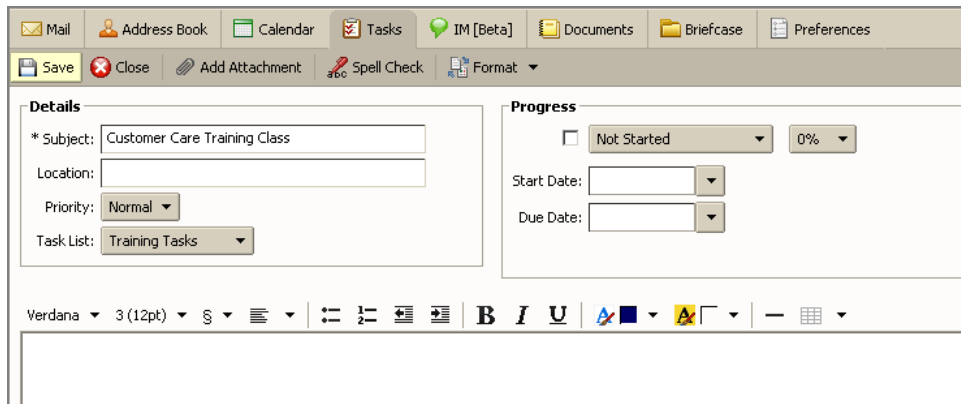

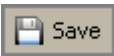
5. Edit the information displayed and click .

## Moving a Task

You can move a task to another list in one of the following ways:

- Using the **Move** option from the right-click menu
- Using drag-and-drop
- Editing the task details

**To move the task using the Move option:**

1. Right-click the task and select **Move**.

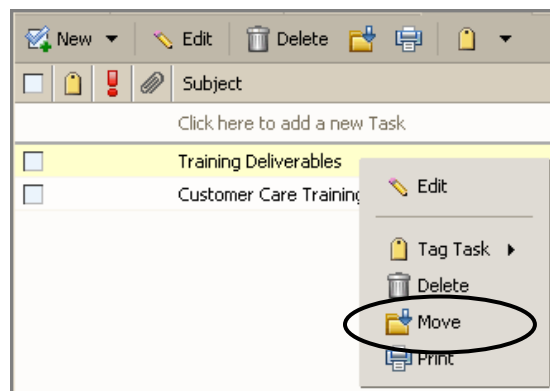

The **Move Task** dialog appears.

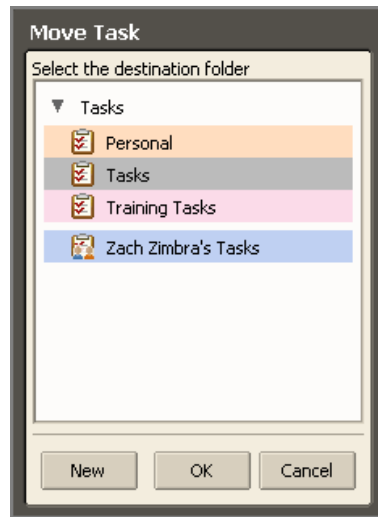

2. Select the task list to which you want to move the task and click **OK**.

**To move the task with drag-and-drop:**

Select the task to move, hold down the left mouse button and drag the task to the lists in the Overview pane.

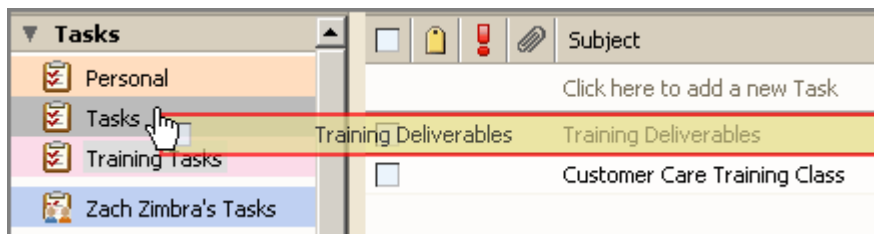

**To move a task by editing the task:**

Open the task page and in the **Task Lists** field, select the task list.

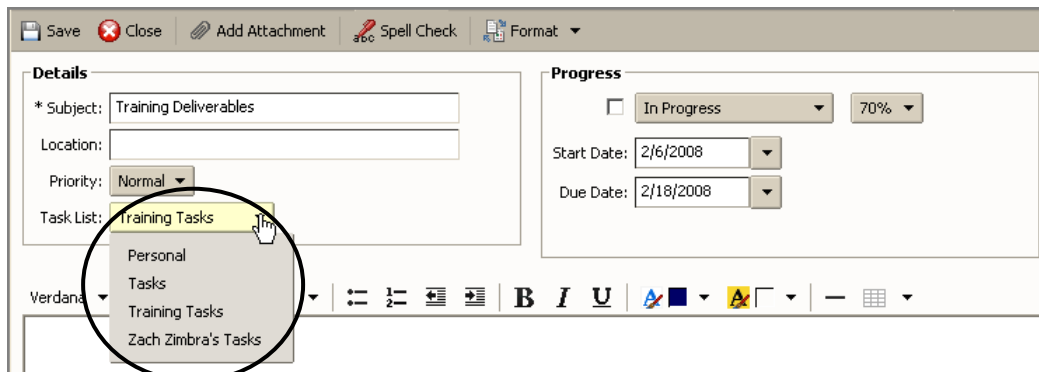

## Deleting a Task

**To delete a task from a task list:**

1. Open the task list containing the task you want to delete. Double-click on the task list in the **Tasks** area of the Overview pane to open a task list.

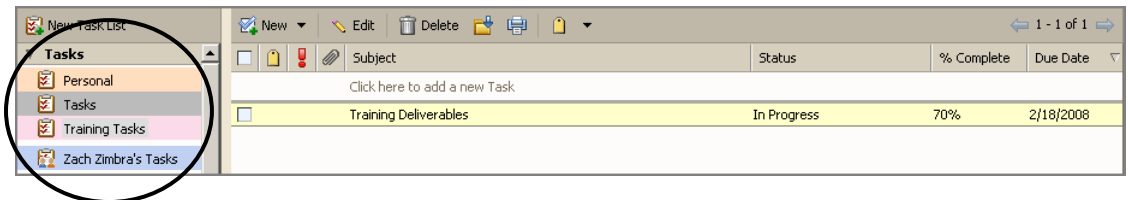

Delete the task using one of the following methods:

2. Select the task to delete and click  **Delete** on the toolbar.
3. Right-click on the task and select **Delete**. Click **Yes** in the Confirmation dialog.

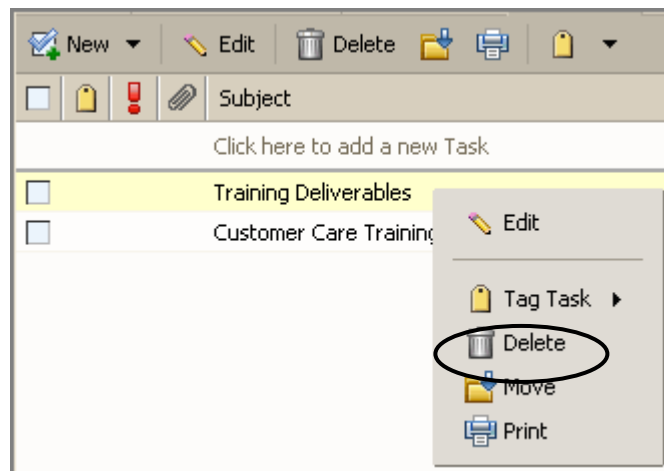

## Sorting Tasks

You can sort tasks in a task list by subject, status, percentage complete, and due date.

**To sort tasks:**

1. Open the task list containing the tasks you want to sort. Double-click on the task list in the **Tasks** area of the Overview pane to open a task list.

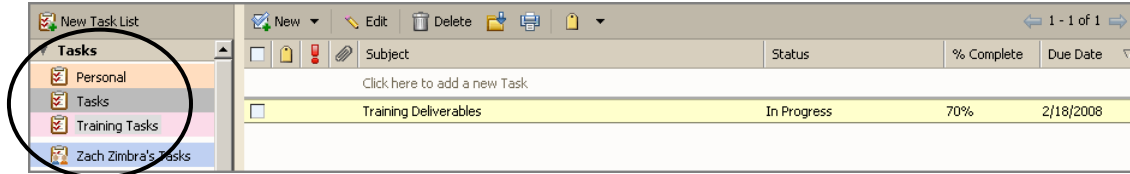

2. Click on any of the following column headers to sort the tasks by that column:
  - o Subject
  - o Status
  - o Percentage Complete
  - o Due Date

## Sharing Task Lists

You can share your task lists with other people in your office, with external guests, and with the public. When you share your task lists with internal users, you can select the type of access the internal users can have, either manager which gives full access to view and modify a task, or viewer, which gives read-only access. External guests and the public have read-only access.



## 12 Working in Documents

---

### This chapter explains how to...

- Create notebooks
- Create and design pages using a rich text editor or using HTML
- Upload and link files and images to different pages
- Search through all notebooks, pages, and attachments

The Zimbra Documents application is a document sharing and collaboration application that gives you a central place on the ZWC to develop and organize information. Images, spreadsheets, and other rich Web content objects can be embedded into Document pages. External documents can also be uploaded. The pages display in your browser.

Zimbra Documents is made up of notebooks with individual pages that are organized in a table of contents.

### Creating a New Notebook

By default, every ZWC account includes one notebook. You can create as many additional notebooks as you need.

#### To create a new notebook:

1. Click the arrow on  in the toolbar and select **New Notebook**. This option is available from the **New** menu in any view, except the Preferences view.

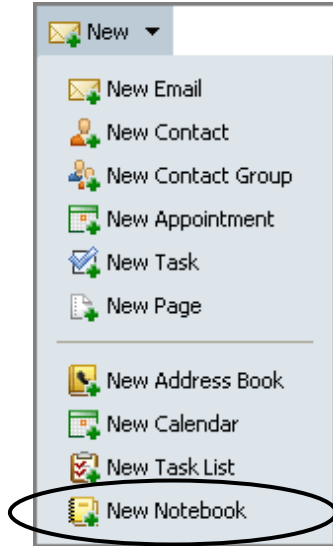

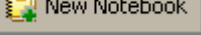
2. Click on  above **Notebooks** in the Overview pane.

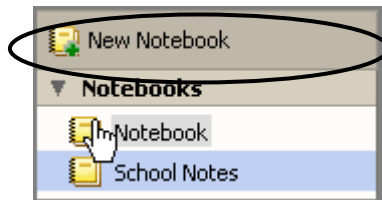

Using either method, the **Create New Notebook** dialog appears.

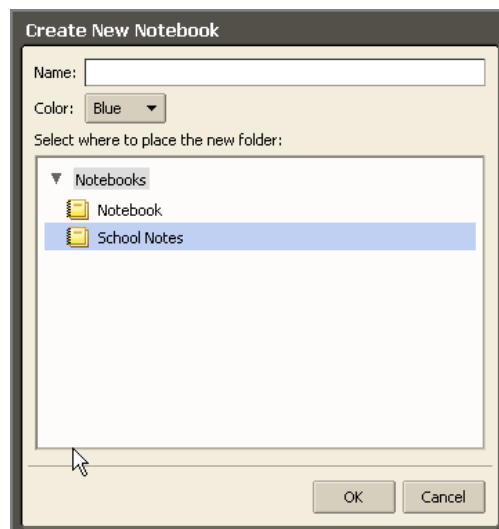

- o Enter a name for the notebook in the **Name** field.

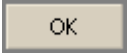
- Select a color for the notebook.
  - Select the location for the notebook.
3. Click . The notebook is displayed in the notebook area of the Overview pane. In the example below, the new notebook is **Training Notebook**, which is pink.

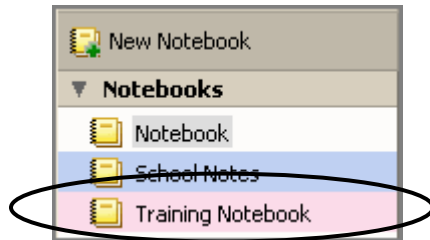

All notebook names must be unique within the hierarchy of your mailbox folders. Notebooks cannot have the same name as any top-level folder in your Zimbra email, calendar, or address book.

## Creating a New Page

You can create a page in a notebook. On any page, you can:

- Design the content layout using either rich-text format tools or HTML tags
- Check the spelling on the page
- Use keywords to easily create links to other pages

### To create a new page in a notebook:

1. Open the notebook to which you want to add a page. Double-click on the notebook in the **Notebooks** area of the Overview pane to open a notebook.

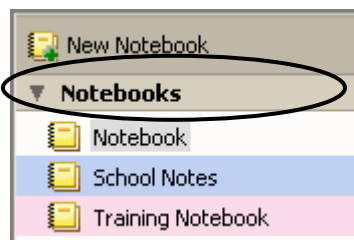

The table of contents page displays in the Content pane.

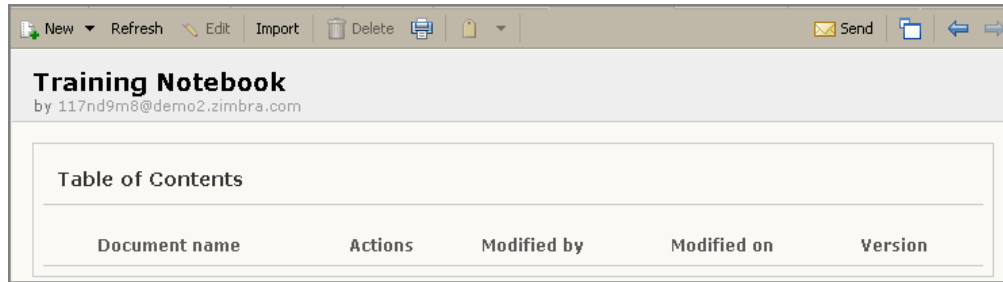

2. Click  on the toolbar. A blank page appears.

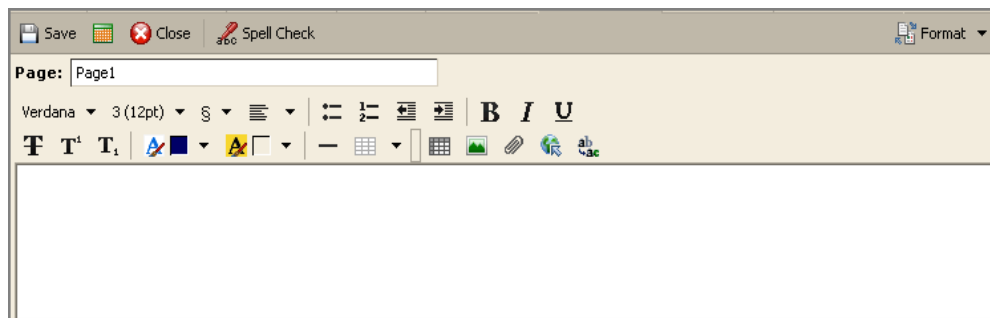

3. Enter the name for the new page in the **Page** field in the header. This name displays in the table of contents.
4. Compose the content of the page. Later you can use either of the following to format this page (instructions for both methods are described later in this chapter)
  - o Default rich text editor to add styles, color, tables, and spreadsheets to your page
  - o HTML tags

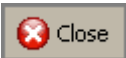
5. Click  to save the page. You can now proceed to format the page, or click  to return to the table of contents page.

## Formatting a Notebook Page: Overview

You can compose your pages using either the rich-text editor to format the content on the page or HTML source to format your page using HTML tags. You can switch between the two formats to take advantage of the rich-text editor features and to insert tables and spreadsheets.

## Formatting a Page Using the Rich-Text Editor

When you edit using the rich-text editor, the two-row toolbar lets you easily format your page layout. Select, change, or add the following:

- Font sizes, faces, and colors
- Text styles
- Background colors
- Tables
- Spreadsheets
- Attachments
- Images

These formatting tools work the same as many word processing tools.

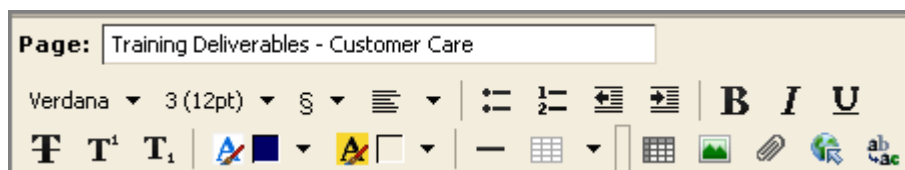

### Adding a Paragraph Style

Use the  icon on the toolbar to view the available paragraph styles. The styles include:

- **Normal** for most paragraphs
- **Headings** (six levels) to identify section titles
- **Address** to make text italic
- **Preformatted** to use when you want to display text in Courier font

These styles cannot be modified, but you can use the editing options to format a style differently. For example, you can change the font, size, color, etc.

### Adding a Table to Your Page

Adding tables to your page is a three-part process: add a table, configure the table properties, and then add content to the table.

**To add a table to a page:**

1. Click  on the toolbar. The table menu is displayed.

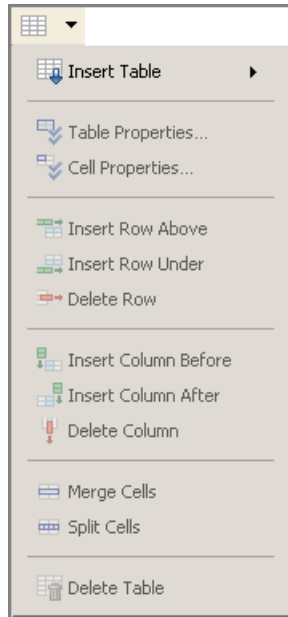

2. Select **Insert Table**, and select how many rows and columns should be in the table.

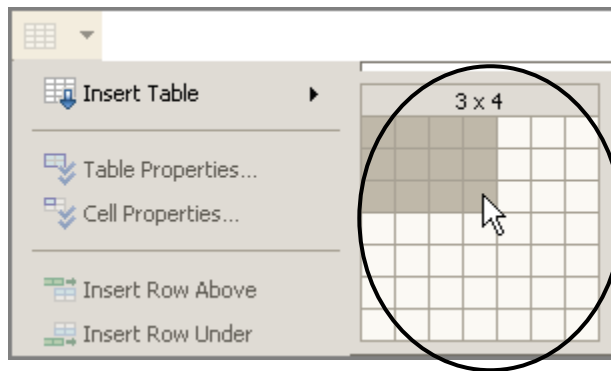

The table is added to the page.

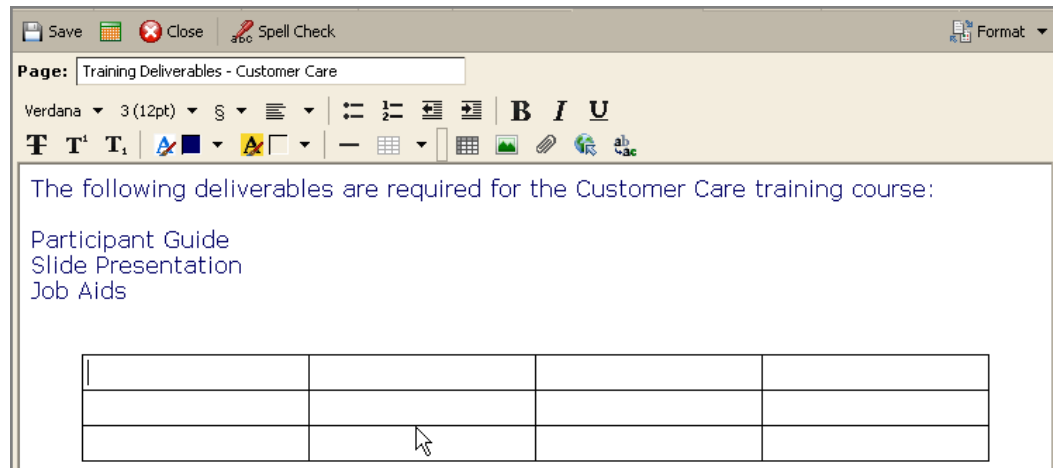

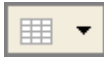
- o To set the table properties, click  on the toolbar and select **Table Properties**. The **Table Properties** dialog appears.

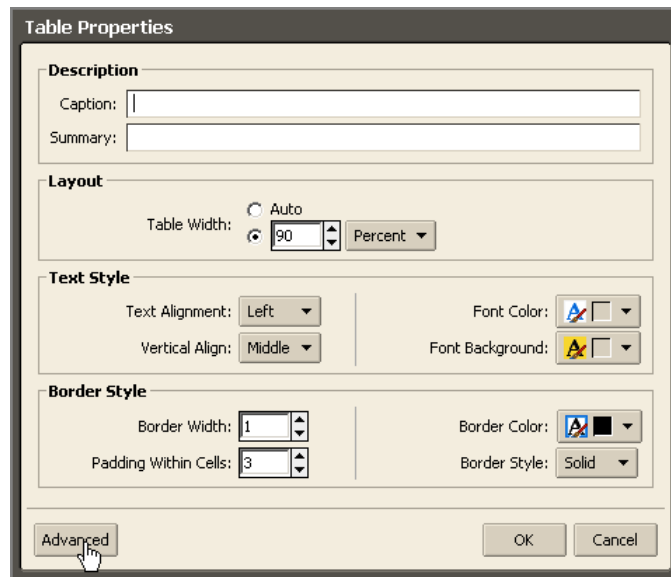

You can define table alignment and width; text style, including font color and table background; and border style, including cell padding.

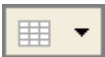
- o To set the cell properties, click  on the toolbar and select **Cell Properties**. The **Cell Properties** dialog appears.

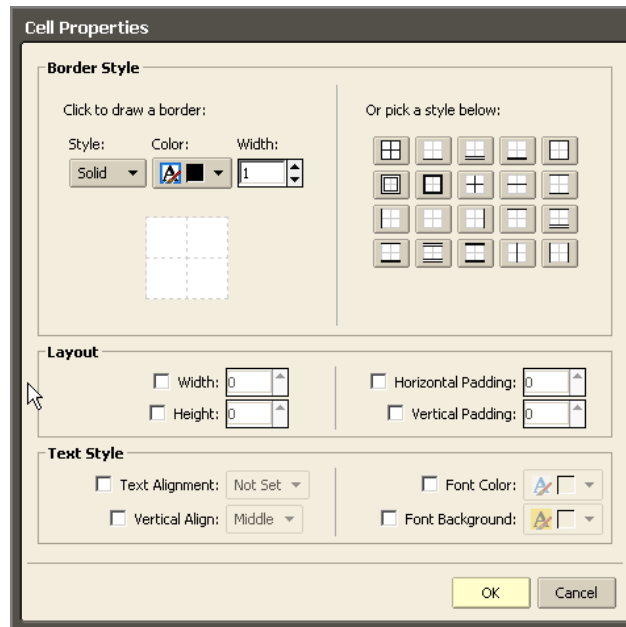

You can define border style for the cell and layout and text styles, including font and background color for a cell.

You can also click  on the toolbar to insert more rows and columns and merge or split cells after you created the table.

After the table properties are set, click on a cell to begin to type text.

## Adding a Spreadsheet to Your Page

To add a spreadsheet, click the spreadsheet icon  on the toolbar. A six-column spreadsheet is added to the page.

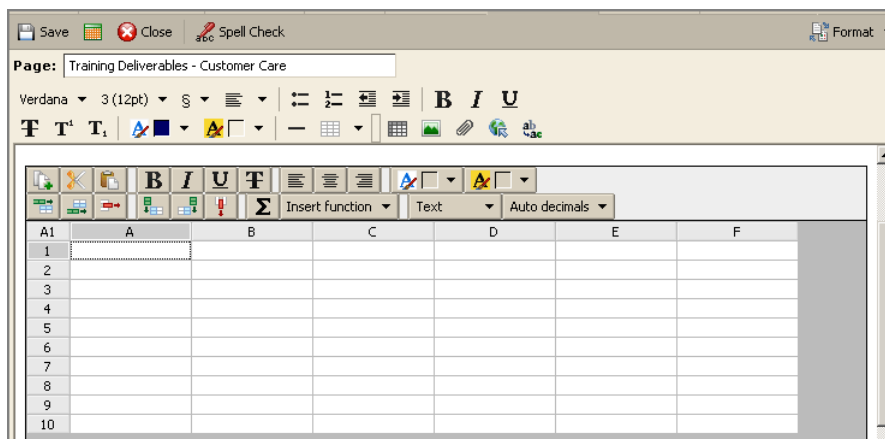





Spreadsheets can be used to create databases to keep track of lists of activities, schedules, tasks to do, etc. The spreadsheet includes basic spreadsheet functionality and a set of predefined functions.

## Adding Attachments, Images, and Links to Your Page

You can upload files and images that link to the notebook page.

- Click  to add a file.
- Click  to add an image.
- Click  to add a link. You can link to other notebook pages or to an external Web URL. Give the link a descriptive title so the URL address does not display.

Browse to find the file or image to be uploaded, or enter a descriptive title for a link (this will be displayed instead of the URL). You are notified if you upload a file that already exists in your Documents.

## Formatting Using HTML Source

If you know HTML, you can use HTML tags to create your content. All basic HTML elements can be used.

### To create pages in HTML:

1. Click **Format** on the toolbar and select **HTML Source**.

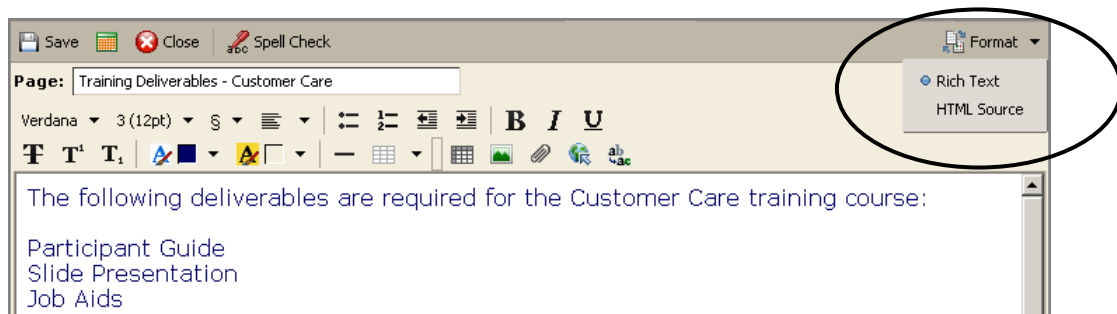

## Sharing Your Documents Notebooks

You can share your notebooks with other people in your organization, with external guests, and with the public. When you share your notebooks with internal users, you can select the



type of access the internal users can have, either manager which gives full access to view, create and edit the notebook's content, or viewer, which gives read-only access. External guests and the public have read-only access.

To learn more about how to share your notebooks, see Chapter 15, *Sharing Your Account Items*.

## 13 Briefcase

---

**This chapter explains how to...**

- Create Briefcase folders
- Upload any type of file to your Briefcase
- Save attachments sent in email messages to your Briefcase
- Work in files in Briefcase

The Briefcase application lets you copy files from your computer to your ZCS account. You can access these files whenever you log in to your ZWC account from any computer and you can share these files with other.

Note: Files in your Briefcase can also be accessed from a WebDAV Client.

### Creating Briefcase Folders

1. Click the Briefcase tab.
2. Click **New Briefcase** on the toolbar.



The **Create New Briefcase** dialog displays.

3. Type a name for the new briefcase folder.



The briefcase folder name must be unique within the hierarchy of your all of mailbox folders. This name cannot match any top-level folder in your mailbox, calendar, or address book. For example, if you have a calendar named Holidays, you cannot name a top-level briefcase Holidays. Holidays could be a name of a briefcase within another briefcase.

4. Select the folder hierarchy, either under Folders or under another briefcase folder. You can create a new top-level briefcase, or you can place it under an existing briefcase.
5. Click **OK**. The new briefcase displays in the Overview pane.

## Adding Files to Your Briefcase Folders

Uploading a file transfers a file from your personal computer to your ZWC account. This makes the file available any time you log into your account. You can upload files in the following ways:

- Clicking attachments you receive with your email messages
- Using the file upload tool when working in Briefcase
- Using WebDav Client tools

### To upload files from Briefcase

1. Open Briefcase, select the Briefcase to save the file and then click Upload file on the toolbar.



2. In the Upload dialog click **Browse** to find the file to upload.

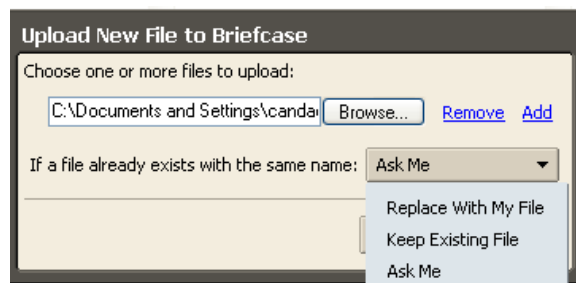

3. To add another file, click **Add**.

You cannot upload a file with the same name to the same briefcase. You can specify on the Upload dialog how to files with the same name should be treated when you attempt to upload the file. When you change this option, the change is saved in the dialog.

- If you want to be notified that you are uploading a file with the same name, select **Ask Me**. If a file has the same name as an existing upload, the **Upload Conflict** dialog displays. You can either keep your existing file or replace it with the uploaded file. You can also view the new file. This the default.
- If you always want the file you upload to replace the existing file with the same name, select **Replace With My File**. The new file is uploaded and replaces the existing file. You are not notified of this.
- If you do not want the files in your Briefcase to be replaced, select **Keep Existing File**. The file is not uploaded and you are not notified.

4. When all files are uploaded, click **OK**. The file is displayed in the Briefcase.

Note: If you selected the wrong briefcase, you can use drag and drop to easily move the file to the correct briefcase folder.

Your account may have a maximum size for upload files. If the file is too large, a warning is displayed. Files that you upload impact your account quota.

### To upload email attachments to Briefcase

Email attachments can quickly be added to your briefcase.

1. To add the attachment, click the **add to briefcase** link in the message header next to the Attachments link.



2. In the **Add to Briefcase** dialog, select the destination folder or create a new briefcase folder.
3. Click **OK**.

## Viewing Files in Briefcase

You can select how to view your files in your Briefcase folders. On the Briefcase toolbar select one of these options from the **View** menu.

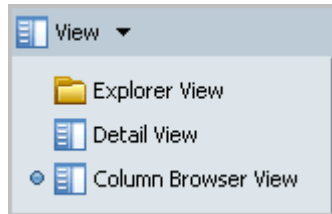

- **Explorer View.** Files are displayed as thumbnails.



- **Detail View.** Files are displayed in a horizontal line with the file size, date uploaded, owner, if a shared file this may not be you, and which folder the file is in.

	Name	Type	Size	Date	Owner	Folder
<input type="checkbox"/>	Sunset.png	PNG Image	4 KB	4/25/2008	charrison	Briefcase
<input type="checkbox"/>	1Intro.fm	Unknown Binary	84 KB	10/26/2007	charrison	Briefcase
<input type="checkbox"/>	Contacting Zimbra Support.pdf	Adobe PDF	102 KB	10/26/2007	charrison	Briefcase
<input type="checkbox"/>	CSStest.css	Text Documents	646 B	10/25/2007	charrison	Briefcase

- **Column Browser View.** Files are displayed vertically. In this view you can click on a file to see information about the file, including size, create date, creator, modified date and modifier.

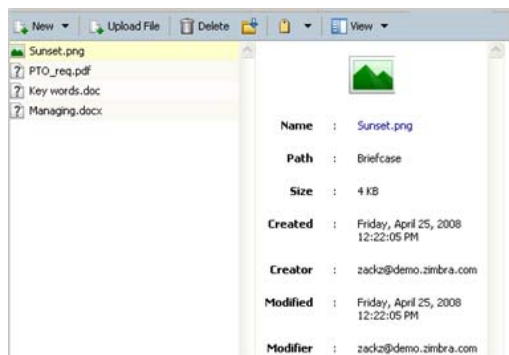

In addition, you can view files using a Web Dev client.

## Working in Briefcase

In Briefcase, you can open files to work in them, move files, tag files and send an email with a link to a file in your Briefcase.



### Opening files in Briefcase

You can open files in your briefcase from any computer. You must have the appropriate software application to open and read or update the file. Common file formats such as text files, HTML files, and images such as .gif or .jpg files can be opened in a variety of programs.

To open a file, right-click on the file and select **Open**.

If the type is unknown, a dialog displays asking what to do with the file, save to disk or open with a specific application.

### Moving files

You can move files from one briefcase to another.

1. On the toolbar, click .
2. Select the destination folder or create a new briefcase folder.
3. Click **OK**.

### Tag files

You can tag files.

1. Click on the file and on the toolbar, click .
2. Select the tag.
3. Click **OK**.

Tags only display in the Detail view.

## Send an email with a link to a file

You can send an email that has a link to a file in briefcase. The recipients must have the appropriate software to open the file and have permission to view the contents.

1. Right-click on the selected file. A confirmation pane opens. Click **Yes** to proceed.

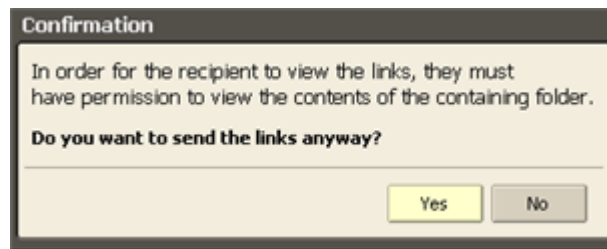

2. A new compose email message opens with the link displayed in the body of the message. Complete the email message and click **Send** to mail the message.

## Sharing Your Briefcase Folders

You can share your Briefcase folders with other people in your office, with external guests, and with the public. When you share your briefcase folders with internal users, you can select the type of access the internal users can have, either manager which gives full access to view, edit, and add files to the shared folder's content, or viewer, which gives read-only access. External guests and the public have read-only access.

To learn more about how to share your Briefcase folders, see Chapter 15, Sharing Your Account Items.



## 14 Searching Your Account

---

### This chapter explains how to...

- Use Quick search
- Use the search syntax to create your own searches
- Use Advanced Search to easily create complicated search queries
- Save your search query

The ZWC lets you search messages, contacts, appointments, notebooks, pages, and files. You can search by:

- Specific words
- Dates and time
- URL
- File size
- Tag
- Whether or not a file has attachments or attachments of a particular file type

There are two mailbox search tools:

**Search.** This is a quick search that executes the search query displayed in the Search text box. The drop-down arrow at the left of the Search box enables you to select the type of item for which to search.

**Advanced.** This search opens a new pane and makes it easier to execute more complex searches. You can save your advanced search queries and re-execute them at a later date.

### Search Syntax

If you are familiar with text-match searches or word-processing features such as the Find/Change in Microsoft Word, note that the content search in the Zimbra Web Client is slightly different from performing a literal string match.



Zimbra search syntax works as follows:

- It is an exact text search. You can search for phrases, but each word within that phrase is matched literally by whole-word only. Spelling variants are not allowed. For example, if you search for **bananas**, messages with **banana** are not a match.
- Search is not case sensitive; **South**, **south**, and **SOUTH** are all the same thing.
- These special characters cannot be used in your search text. ~ ' ! @ # \$ % ^ & \* ( ) \_ - + ? / { } [ ] ; : "
- The asterisk \* as a wildcard after a prefix is supported. For example, if you search for **do\***, it returns items with the word dog, door, etc.

Searching for content will search the body of a message plus any (system-readable) file attachments it may have. A system-readable file attachment is a type of file that can be converted to HTML-viewable text. These attachments include Microsoft Office documents (Word, PowerPoint, or Excel), as well as text files. You cannot search for image and audio files.

## Using Quick-Search

The search feature is a powerful tool. It provides a quick shortcut to searching without keywords. For example, to find all email containing the word **tim** anywhere in the **Subject** line, **To**, **From**, **Cc**, or **Bcc** lines, message body, or file attachment, simply type **tim** into the search box and click **Search**.

You can enter any value, such as a word, first name, last name, phone number, or domain name. To search for contacts in your address books, the search field must contain a whole word or number string. For example, to search contacts by phone number, you have to enter the full phone number as it appears in the contact entry; you cannot search by the area code alone.







### To perform a quick search:

1. Enter the search query into the Search field.

The screenshot shows a search bar with a text input field on the left. To its right is a dropdown menu with a yellow envelope icon and the text 'Email' and a downward arrow. Further right are three buttons: 'Search', 'Save', and 'Advanced'.

2. Select one of the following options from the search type drop-down menu:

-  to search all items in your mailbox

-  Email to search email messages
  -  Contacts to search contacts in your personal address book
  -  Appointments to search appointments
  -  Tasks to search your tasks
  -  Pages and Files to search notebook pages and files
3. Click .

## Advanced Search Criteria

The Advanced search features opens separate mini-panes to perform different types of searches. You can open multiple instances of each mini-pane. You might want to do this if you are doing AND type searches.

Refer to the table below for advanced search criteria.

Criteria	Description
Basic	Search header information such as From, To, and Subject. Search the content of messages and attachments for a specific word or phrase.
Attachment	Search for No Attachment, Any Attachment, or Specific Attachment. If you select specific attachment, a list of attachment types is displayed.
Date	Search for messages received after, on, or before a selected date. Open two Date panes to search between dates.
Domain	Search for messages where the address headers (From/To/Cc) contain addresses from certain domains. The domains that you can search for are pre-defined with check boxes.



Criteria	Description
Folder	Limit search to selected folders only.
Saved Search	Open a search query you previously saved.
Size	Search for messages that are larger or smaller than a specified size (bytes, KB, or MB).
Zimlets	Search for messages or contacts containing URLs, phone numbers, or other objects as defined by your administrator.
Status	Search for messages or contacts that are flagged or unflagged. Search for messages that are read, unread, forwarded, or replied to.
Tag	Search for messages or contacts that have a specific tag or a specified set of tags.
Time	Search for messages that arrived within a time-frame, such as the last hour, this week, last month, etc.

## Searching for Messages with Quick Search

To search for messages using Quick Search:



1. Enter search criteria in the **Search** box. For example, enter a sender's name.
2. Select an option from the Search drop-down menu. Email is the default.

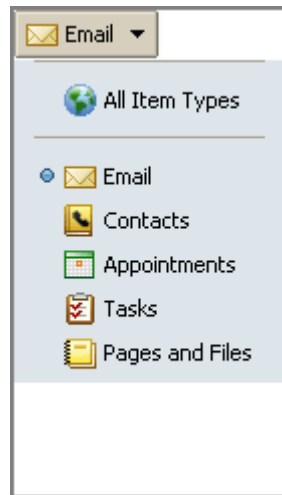

3. Click . Search results are displayed in the Content pane.
4. Click any tab on the menu to exit the search.

## Searching for Messages with Advanced Search

To search for messages using Advanced Search:

1. Click **Advanced** to open the Advanced search area.



The Advanced search panes appear, with the **Basic Search** pane displayed.

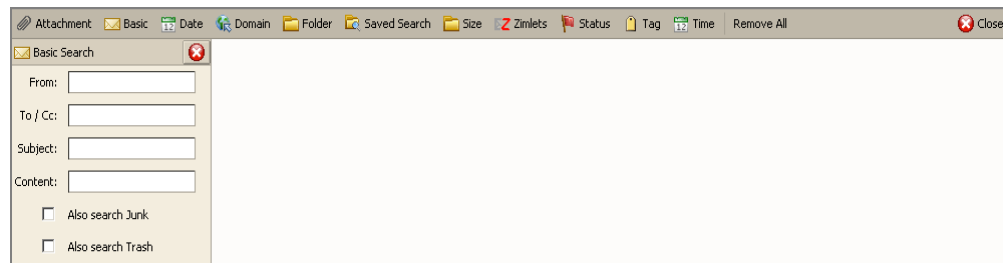



2. Depending on your search requirements, click an icon in the toolbar to open the appropriate pane. Each time you click an icon, another pane is displayed.
3. Enter information in the pane fields.

If you enabled **Always Show Search String** on the **Preferences > General** tab, the search text box updates as you type or make selections.



- **Search Execution.** When you enter a criterion in a search pane, or as soon as you have made any selection change in a search pane, the search executes. Therefore, if you enter text in a field, the search executes. If you select a radio button, the search executes. Etc.
- **Search Results.** Items matching the search criteria are listed in the Content pane. If the Conversation feature is enabled, conversations containing messages that match the search criteria are listed.

4. **Refresh.** Click  to refresh the search results area.
5. Click  to exit the search.

## Advanced Search Example

To search for a specific type of attachment file. A message with a news clip attached. You don't remember who it's from or what date it was sent, but the filename has a .PDF extension.

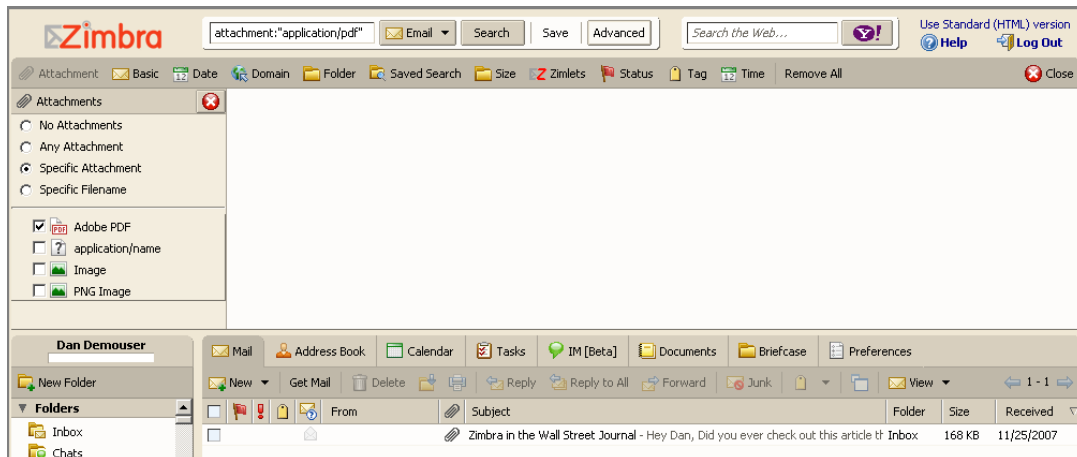

How it was done:

- Select **Email** from the search drop-down menu.
- Click **Attachments** in the Advanced search area to open just the **Attachments** pane.
- Choose **Specific Attachment**. A list of check boxes appears beneath the radio button. Check the box next to **Adobe PDF**.

An email message is displayed in the search results area (the Content pane).

## Using \* as a Wildcard in Search

The asterisk \* can be used as a wildcard in a search to find content with words that have similar spellings.

Use the asterisk \* as a wildcard after a prefix. For example, **do\*** returns items with the word dog, door, etc.

## Saving a Search Query

If you create a search that you think you will want to use again, you can save it.

To save a search:

1. Create the search query, either by entering text in the **Search** bar or by creating a query with **Advanced** search.

2. Click  in the **Search** area to save the search.



The **Save Search** dialog appears.

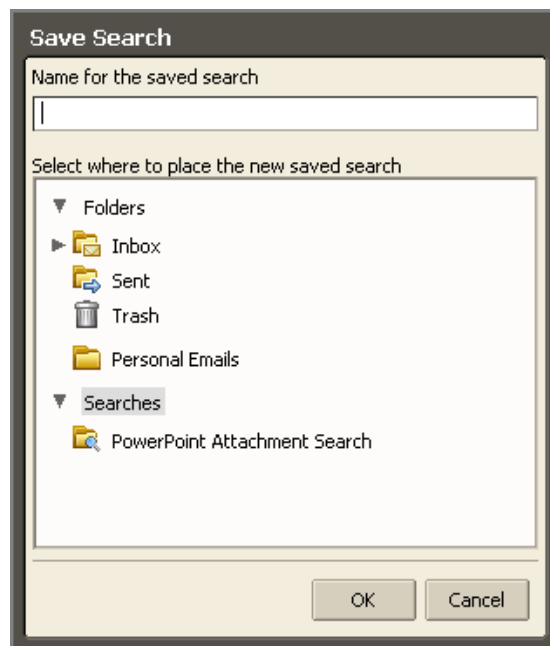

3. Enter a name for the search into the field.



4. Select where to place the saved search. Searches are saved as a Searches folder in the **Searches** section of the Overview pane by default, but you can select another folder.

5. Click .

The saved search is displayed in the Overview pane.

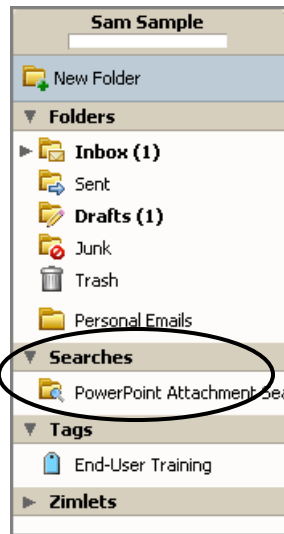

To use a saved search, click the search folder. The search results immediately display in the Content pane.

## Search Examples

The different panes in the Advanced search area can be used to search by different criteria. The following examples include which Advanced search panes you would use.

Here are a few possible search examples:

- **To search for an attachment that may be one type or another.** Messages with either PDF attachments or JPEG attachments.



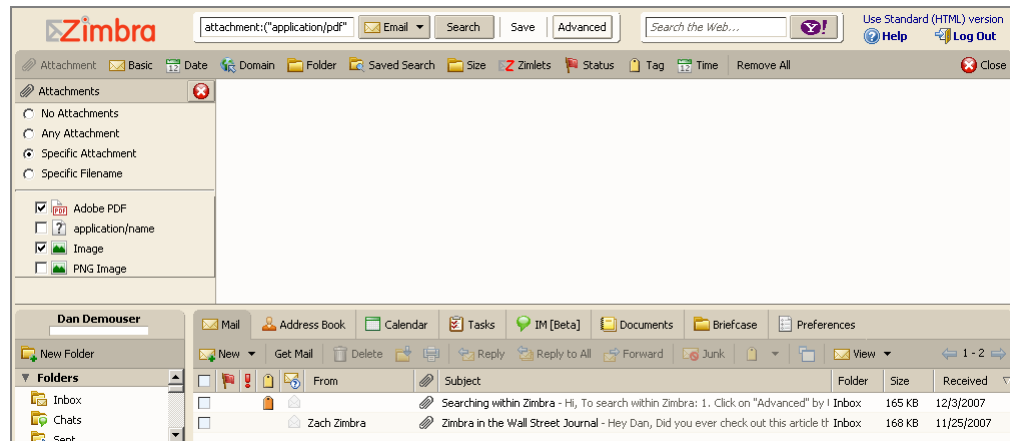

How it was done: Select **Email** from the search drop-down menu. In the Attachments pane, choose **Specific Attachment** and then check both **Adobe PDF** and **JPEG Image**.

- To search for a contact within a specific company. A contact who works at a company called Zimbra.

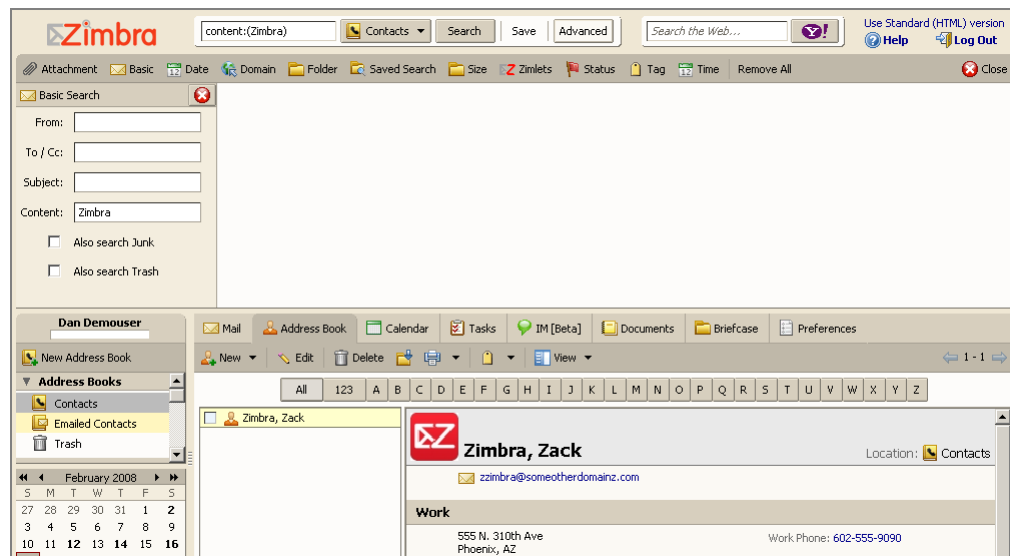

How it was done: Select **Contacts** from the search drop-down menu. In the Advanced search area, open the **Basic Search** pane. Enter **Zimbra** in the **Content** field. (You could also do this search without using Advanced Search.)

- To search for an item that was tagged. Description of the new procedures for your industry, which you had tagged as **Industry News**.

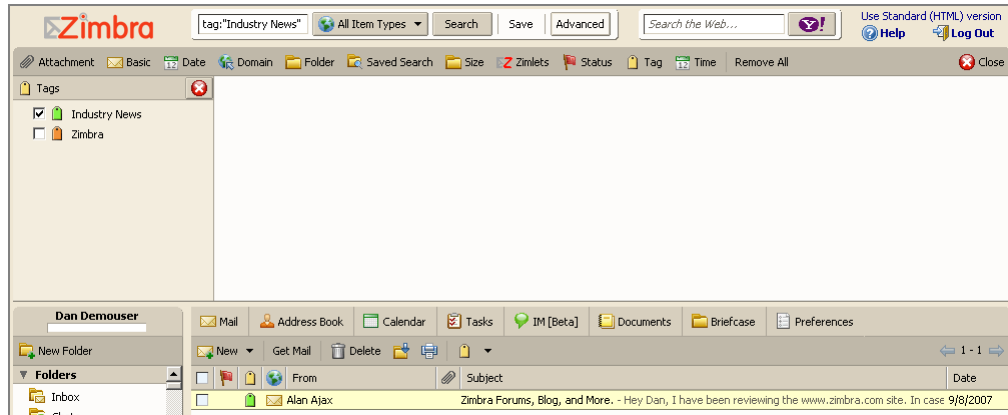

How it was done: Select **All Item Types** from the search drop-down menu. In the Advanced search area, open the **Tags** pane. Select the check box for the **Industry news** tag. Note that tags are user-defined, so this assumes that you have previously 1) created the tag definition, and 2) applied it to objects in your mailbox.

- **To search by a date range.** Search for a message someone claims to have sent you in early December.

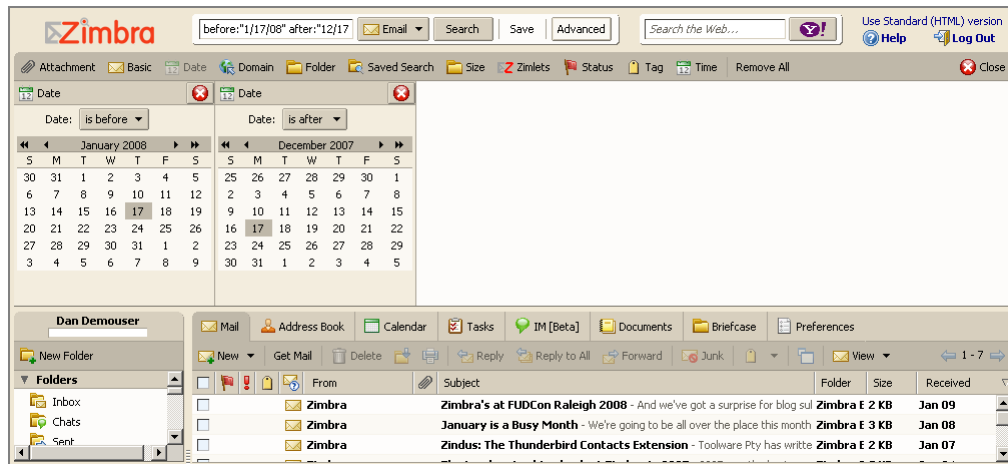

How it was done: Select **Email** from the search drop-down menu. In the Advanced search area, open two instances of the **Date** pane to set the date range. In the first one, set the **Date** drop-down to **is before** and select an end date. Use the other **Date** pane to specify **is after** and a start date. You can also search by sender using a basic search.



## 15 Sharing Your Account Folders

---

### This chapter explains how to...

- Share folders from your Mail, Address Book, Calendar, Tasks, Documents notebooks, and Briefcase folders
- Set up sharing with others
- Cancel a shared folder
- Accept a share invitation
- Work in shared folder
- Link to a shared folder

You can share your mail folders, address books, calendars, task lists, Documents notebooks, and Briefcase folders. Sharing your ZWC items lets you collaborate with others, letting them make changes to or just view the folder details. The process to share an folder is as follows:

- The grantor selects the folder to share: email folder, address book, calendar, notebook, task list, or Briefcase folder.
- The grantor decides with whom to share and the access privileges, manager or view-only, the grantee can have, and then sends them an invitation.
- The grantee accepts the invitation and gets access to the shared folder.

### Selecting Access Privileges

From within the appropriate application, you select the folder and specify the type of access privileges to give the grantee. You can share with internal users, who can be given complete manager access to the folder or only the ability to view the folder.

You can set permissions per user or group, so everyone does not have to have the same permissions to your shared folder.

You can share with the following:

- **Internal users or groups.** You select the type of privileges (role) to grant to internal users. The user or group must have a valid address in your company's mail server.



- **Viewer.** The grantee can read the contents of the shared folder, but cannot make changes to the content.
- **Manager.** The grantee has full permission to view and edit the content of a shared folder, create new sub folders, edit and delete files in the shared folder.
- **None.** An option to temporarily disable access to a shared folder without revoking the share privileges. The grantee still has the shared folder in his mailbox but cannot view or manage activities on the grantor's folder.

**Note:** You can share your Mail folders only with internal users or groups.

- **External guests.** You create a password for the shared folder that guests must enter to view the content. They cannot make any changes to the information they view.
- **Public.** Anyone that knows the URL to the folder can view the content. They cannot make any changes to the information.

**Share Properties**

Name: Inbox  
Type: Mail Folder

Share with:

- Internal users or groups
- External guests (view only)
- Public (view only, no password required)

Email:

**Role**

- None None
- Viewer** View
- Manager** View, Edit, Add, Remove, Accept, Decline

**Message**

Send standard message

**Note:** The standard message displays your name, the name of the shared item, permissions you have granted to the recipients, and login information, if necessary.

**URL**

To allow others to access this item, direct them to this URL:  
<https://dogfood.zimbra.com/home/charrison/Inbox>

OK Cancel

## How Sharing Works

The access privileges for each application is described in the following sections.



---

## Sharing Your Mail Folders

You can share any of your mail folders, including the Inbox folder and sub-folders, with valid users within your organization. You cannot share your mail folders with external users or with the public. A copy of the shared folder is put in the grantee's Folder list on the Overview pane. When the folder is selected, the content displays in the Content pane. The grantee do not need to log into the grantor's mailbox.

Grantees that has the manager role have full permission to view and edit the contents of the shared mail folder, create new sub-folders, send email on the grantor's behalf, and delete email messages.

### Scenarios for sharing a mail folder

- Your sales department wants one central mailbox for all email messages requesting information about your product, and everyone in sales should be able to view email messages immediately when they come in. You can give everyone in the department permission to view the mail folder and they can copy the messages to their mailbox, or you can give them permission to manage the mail folder and they can reply on behalf of this address.
- A manager is often out of the office and does not have time to respond to her email messages. When the manager delegates access to her Inbox mail folder, her assistant (grantee) can manage the content of her mail, respond to messages on her behalf, create folders to organize message in that mail folder, and delete messages.
- Instead of sending email messages to dozens of addresses every time you have an announcement, you can identify one of your folders as a public folder that contains the email announcements. You can create shared access to only specific email addresses and set a password that must be entered to view the content, or you can make it a public URL for anyone who has the URL can view the content.

## Sharing Address Book Contact Lists

You can share any of your address books with other people in your office, with external guests, and with the public. Depending on the role you assign to the grantee, the shared contacts list can be view-only or manager which has full access privileges to edit, add, and delete contacts in the address book.

Sharing your address book is useful if your address books are for specific categories of contacts and you want other users to have access to the names.

## Sharing Calendars

You can share your calendars with other people in your office, with external guests, and with the public. Depending on the privileges you assign to the grantee, the shared calendar can be view-only or manager which has full access privileges to create meetings, accept or decline invitations, and edit and delete activities on the shared calendar.

## Sharing Task Lists, Documents Notebooks, Briefcase Folders

You can share your task lists, Documents notebooks, and Briefcase folders with other people in your office, with external guests, and with the public. When you share your folders with internal users, you can select the type of access the internal users can have: either manager, which gives full access to view and modify the content of the shared folder; or viewer, which gives read-only access. External guests and the public only can have read-only access.

## Setting Up Shared Folders

When you select the item to share, you can select the top level folder or you can select a specific folder under the folder. If you select to share the top-level folder, all folders within that folder are also shared.

1. Right-click on the folder you want to share.

**Note** When you share your mail folders, you cannot share the Trash or Junk folders.

2. Click **Share Folder**. The **Shared Properties** dialog displays. Select whom to share with; Internal user or groups, External guests, or Public.

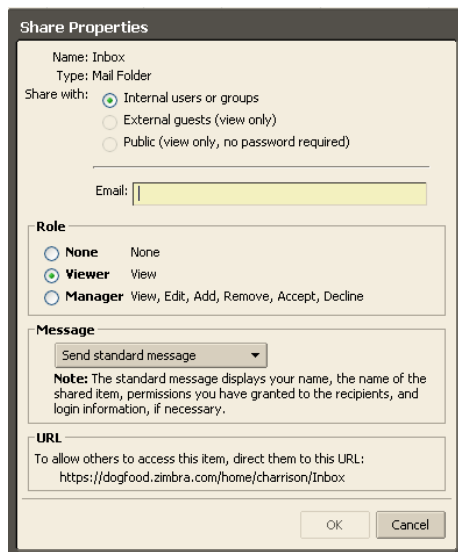

**Share Properties**

Name: Inbox  
Type: Mail Folder

Share with:

- Internal users or groups
- External guests (view only)
- Public (view only, no password required)

Email:

**Role**

- None None
- Viewer** View
- Manager** View, Edit, Add, Remove, Accept, Decline

**Message**

Send standard message

**Note:** The standard message displays your name, the name of the shared item, permissions you have granted to the recipients, and login information, if necessary.

**URL**

To allow others to access this item, direct them to this URL:  
<https://dogfood.zimbra.com/home/charrison/Inbox>

OK Cancel



3. Depending on with whom you share, you do the following:
  - For **Internal users or groups**, enter the email addresses and in the **Role** area select the access privileges.
  - For **External guests**, enter guest's addresses and the password to enter to view your mail folder.
  - For the **Public**, direct the public to the URL that displays in the **URL** area. For example, you could copy and email this URL to those you want to view the page.
4. In the **Message** area select which type of message to send. This message can be sent to internal users and to external guests. The options are as follows:
  - **Do not send mail about this share.** No message is sent.
  - **Send standard message.** The standard share notification message is sent to the email address. This message includes the name of the mail folder that is being shared, your address, the grantee's address and the role assigned, with a list of the allowed actions.
  - **Add a note to standard message.** You can add additional information to the standard message.
  - **Compose email in new window.** Create and send a new email message.
5. Click **OK**.

**Note:** Remember, if you selected **Public**, you will need to notify the public of the URL.

## Changing or Cancelling Access

You can cancel the share privileges and edit the grantee's role from the Share Properties dialog.

## To change access permissions

1. From the appropriate application, right-click on the shared folder to change.

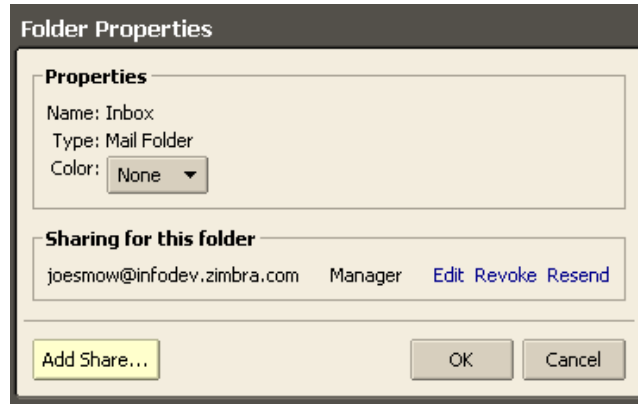

2. Select **Edit Properties**. The **Folder Properties** dialog opens. This dialog displays the names that share the folder.
3. In the **Sharing for this folder** section, click **Edit** by the name to change. The **Share Properties** dialog opens. You can change the privileges.
  - **Viewer**. The grantee can read the contents of the folder, but cannot change it.
  - **Manager**. The grantee has full permission to view, edit the contents of a folder, add new pages and remove pages.
  - **None**. This is an option to temporarily disable access to a grantor's shared folder without revoking the share privileges. The grantee still has the folder in their list, but cannot view or manage activities in the folder.
4. An email message will be sent to notify the user, or you can select to either not send an email message or to send a standard or composed message.
5. Click **OK**.

## To cancel access

1. From the appropriate application, right-click on the shared folder.
2. Select **Edit Properties**. The Folder Properties dialog opens. This dialog displays the names that share the folder.
3. Click **Revoke**. A Revoke Share dialog opens. An email message will be sent to notify the user, or you can select to either not send an email message or to send a customized message.





4. Click **OK**. The user can no longer access your folder. The user can delete the folder from their Overview pane list.

## Accepting an Invitation to Share Items

If you receive an email notice that you have been granted access to share another person's mail folder, you can accept or decline the share.

When you accept the share, the shared folder displays in the specified application's list in the Overview pane.

### To accept

1. Click **Accept Share** in the email. The Accept Share dialog opens and describes the role granted to you.

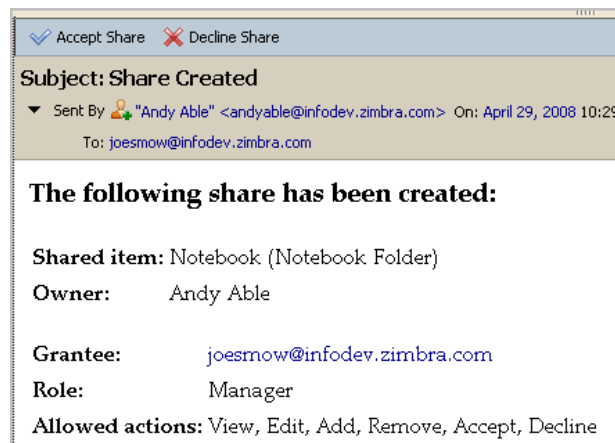

2. Before you accept, you can change the folder name and select a color to high-light the folder.

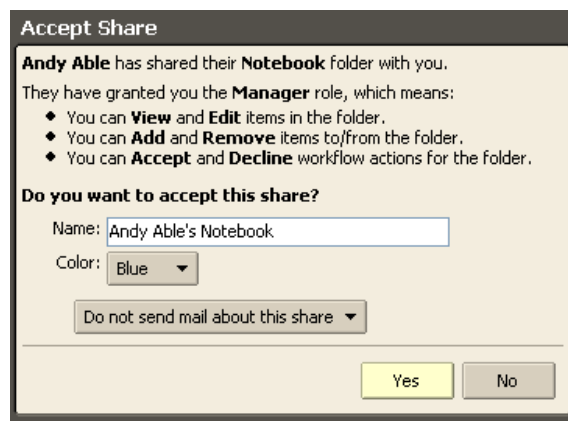

3. (Optional) Select to send a confirmation back to the Grantor.



4. Click **Yes**. The folder is added to the grantee's Overview pane. The message is moved to your Trash folder.

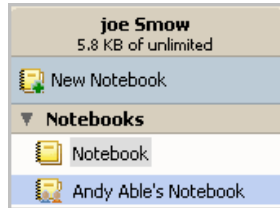

## Working within a Shared Folder

When you accept to share a grantor's folder, the folder is displayed in your Overview pane.

When you open the folder, you see the content of the folder. This information is not actually saved in your mailbox.

- When sharing a **Mail folder**, the grantees can open the email and if they were granted permissions of Manager, they can reply to, forward, or delete the message. Copies of the messages the grantee sends are saved in the grantor's mailbox, and if the grantee delete something from the grantor's mailbox or marks it as spam, the message is moved to the grantor's Trash folder or Junk folder.

If the grantee has access to more than one of the grantor's folders, the grantee can

- Move the contents from one folder to another folder in the grantor's mailbox.
  - Copy an email message from the grantor's folders to the grantee's mail folders. The grantor's mail folder also retains a copy.
  - Create folders within the shared mail folder and the new folder appears in the grantor's mailbox.
- When sharing an **Address Book folder**, the grantee with manager's permission can add, delete, and edit contacts in the address book.
  - When sharing a **Calendar folder**, the grantee with manager's permission can add, delete, and edit meetings and appointments on the calendar.
  - When sharing a **Task list**, the grantee with manager's permission can add, edit, and delete tasks in the task list.
  - When sharing **Documents notebook**, the grantee with manager's permission can add pages, edit and delete pages in the notebook. The version control lets users know when a page was last updated and who updated it.



- When sharing a **Briefcase folder**, the grantee with manager's permission can add new files to the folder, edit existing files if they have the appropriate software, and delete files. The detailed information shows when a file is modified and who modified it.

## Linking to Shared Items

In addition to accepting email notification that you have been granted access , you can also establish links to shared folders by using the **Link to Shared** dialog. For example, this may be the case when your organization has public notebooks that you want to view but not manage.

**Note:** The access privileges you have are set by the grantor.

1. In the appropriate application, right-click on the application header and select **Link to Shared**. A dialog opens.

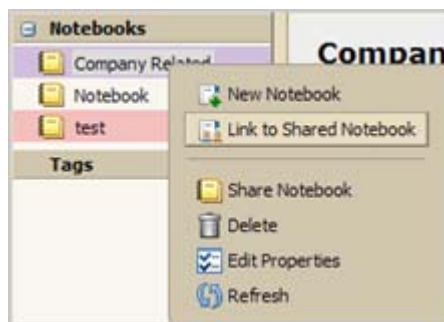

2. To add the shared folder link, you must know the email address of the owner and the name of the shared folder. For example, Jdoe@example.com created a notebook called Projects with second notebook under Projects called Project 1. Jdoe then shares Project 1 with you.

**Link to Shared Notebook**

To link to an item that has been shared with you, enter the owner's email address and the location of the folder in their mailbox (e.g. Work/Projects):

Email:

Path:

Properties of your new link:

Name:

Color: Blue ▾

OK Cancel

In order to access Project 1, enter the information as follows:

- Email. jdoe@example.com



- Path. projects/project1
  - Name. The name auto-completes with the email name and the path. You can change this.
  - Color. Select a color from the list (optional)
3. Click **OK**. The notebook is added to your Notebooks list.



## Appendix A: Standard Zimbra Web Client

---

### Overview

The appendix gives a brief introduction to the standard Zimbra Web Client, including features available and navigation overview. The standard ZWC is a non-Ajax web UI for poorer connections, legacy browsers, or easier accessibility. Features that are available and general navigation around the applications is different.

### Features Available on the Standard ZWC

The table that follows lists the main features of the ZWC and whether the feature is available in the standard ZWC.

Feature	Description	ADV ZWC	STD ZWC
<b>General Web Interface</b>			
AJAX-based end user interface	Rich, interactive, web-based interface for end user functions (access via HTTP or HTTPS)	✓	
Online end user help	Online end user help accessible directly from the end user interface	✓	✓
Themes	Ability to customize the colors and appearance of the web interface	✓	✓
<b>Cross-Application Features</b>			



Feature	Description	ADV ZWC	STD ZWC
Drag/Drop with drag context	Ability to drag/drop items, with dynamic indicators of the number of items being dragged and valid drop zones	✓	
Auto-complete addresses	Addresses auto-complete as they are being typed, including a dynamically updated selection dialog when multiple addresses match	✓	✓
Tags	Ability to quickly categorize messages, contacts, and/or documents by attaching "Tags" with user-defined names and colors *Standard can only tag mail	✓	✓*
HTML formatting	Ability to render and create messages, appointments, and web documents in HTML format	✓	✓
Spell check	Option to check and correct spelling in a mail message, calendar appointment, or web Document *Standard – HTML compose must be checked	✓	✓*
Zimbra Assistant	Mini dialog for quick actions (e.g. send message, create appointment) without changing the underlying application context	✓	
"View as HTML" option for attachments	Option to quickly view attachments in HTML format	✓	
Keyboard Navigation	Keyboard shortcuts are available for Zimbra Web Client	✓	✓



Feature	Description	ADV ZWC	STD ZWC
Custom keyboard navigation shortcuts	Users can create custom shortcut keys for folders, tags, and saved search from their Options page	✓	
<b>Mail</b>			
Conversations	Automatic grouping of messages in a message thread, enabling efficient message organization	✓	✓
Preview pane	Ability to view a highlighted message in a preview pane	✓	
Subscribe to RSS/ATOM feeds	Ability to subscribe to RSS/ATOM feeds	✓	✓
Message print and print preview	Ability to print a message and see a print preview	✓	✓
Message sort	Ability to sort messages based on subject, date, or sender	✓	✓
Flags	Ability to flag/unflag messages/conversations for follow up	✓	✓
Filters	Ability to define filter rules and priorities for incoming messages	✓	✓
Away messages	Ability to enable/disable a custom away message	✓	✓
Signatures	Ability to add a custom signature to a message	✓	



<b>Feature</b>	<b>Description</b>	<b>ADV ZWC</b>	<b>STD ZWC</b>
Compose in window	Option to popup a separate window when composing a message	✓	
Drafts	Ability to save in-progress messages to a Drafts folder	✓	✓
User-controlled forwarding	Ability for a user to set an automatic forwarding address and choose whether to leave a copy in the primary mailbox	✓	✓
Reply with attachments option	Option to Reply or Reply-All while retaining the attachments from the original message	✓	
Right-click message context menu	Right-clicking a message displays a menu of actions to take on that message (e.g. Mark Read, Reply, Delete)	✓	
Right-click email address context menu	Right-clicking an email address displays a menu of actions to take on that address (e.g. view website, add/edit contact, create filter, search for messages)	✓	
Hover over attached image shows preview	Hovering over an image attachment in a message displays a thumbnail preview of the image	✓	
Create calendar appointment from message	Ability to drag a message to a mini-calendar date to create an appointment based on the message	✓	





Feature	Description	ADV ZWC	STD ZWC
Quota indicator	Visual indicator of quota and amount of quota consumed	✓	✓
Export messages as ZIP file	Ability to export a set of messages as a ZIP file	✓	
Reply/Reply-All Toggle	Ability to toggle between Reply and Reply-All while composing a reply	✓	
Persona (Mail Identities)	Ability to create multiple identities in Zimbra Web Client and use different names and mail settings.	✓	
Support for multiple external email accounts	Within ZWC, users can identify other POP email accounts that they have, retrieve email from those accounts and save in specific folders	✓	
Reading Pane view can be set	Users can set their default preference for viewing messages in the reading pane	✓	
User-specified default HTML settings	Users can set the default font family, font size and font color to use when composing email messages and Documents pages	✓	✓
Ability to insert inline images in HTML Editor	Users can insert inline images in email messages and calendar appointments	✓	✓
Different signatures can be defined	Users can define ✓ different email signatures to use	✓	✓



Feature	Description	ADV ZWC	STD ZWC
Checkboxes to select mail	Users can check multiple emails in the list view to mark as read/unread/tag, delete, or to move to a different folder	✓	✓
Message priority can be set	When sending a message, the priority is normal, but it can be set to high or low as well	✓	
Multiple messages can be forwarded	Multiple messages can be selected and forwarded in one email	✓	
Aggregation of mail accounts using IMAP	Users can aggregate multiple external accounts in their Zimbra account using IMAP	✓	
View the number and total size of items in folder	Users can right click on a folder to see the number of messages and the total size of items in folder	✓	
<b>Address Book</b>			
Import/export contacts in CSV format	Ability to import/export Contacts in .csv format	✓	✓
Multiple Address Books per mailbox	Ability to create multiple Address Books in a single mailbox	✓	✓
Move/copy contacts across Address Books	Ability to move/copy contacts from one Address Book to another (based on access privileges)	✓	✓



Feature	Description	ADV ZWC	STD ZWC
Personal Distribution Lists (Group Lists)	Ability to create group contact lists in their user Address Books	✓	✓
<b>Calendar</b>			
Personal scheduling	Ability to schedule personal appointments	✓	✓
Group scheduling	Ability to schedule meetings and view attendees' free/busy information	✓	
Recurrences and recurrence exceptions	Ability to create recurring meetings and exceptions to recurring meetings	✓	✓
Resource scheduling	Ability to book resources (locations, equipment, etc.) for a meeting	✓	
Calendar alerts	Option to enable an alert popup for upcoming appointments	✓	
Time zone adjustment	Appointments/schedules are automatically displayed in the users current time zone	✓	✓
Day, Week, Work Week, Month views	Ability to view calendars in Day, Week, Work Week, or Month views	✓	✓
Customizable first day of week	User setting for the first day of the week; value chosen impacts the Week calendar view	✓	✓



Feature	Description	ADV ZWC	STD ZWC
Create/drag appointment inline in calendar views	Ability to create an appointment and/or drag an appointment's boundaries inline in calendar views	✓	
Quick Accept/Tentative/Decline from calendar views	Ability to quickly mark Accept/Tentative/Decline from calendar views	✓	
Faded display of declined appointments	Declined appointments display faded so that the user remains aware of their occurrence	✓	
Calendar print and print preview	Ability to print calendars in day, week, work week, or month views and see a print preview	✓	
Hover over appointment shows details	Hovering over an appointment in calendar view displays additional appointment details	✓	
Mini-cal	Option to display a miniature calendar at all times	✓	
Hover over date in mini-cal shows schedule	Hovering over a date in the mini-cal displays calendar information for that date	✓	
Multiple calendars per mailbox	Ability for a user to create multiple calendars within a single account	✓	✓
Free/busy inclusion	Ability for a user to designate which calendars will	✓	✓



Feature	Description	ADV ZWC	STD ZWC
by calendar	be included in the user's free/busy calculations		
Subscribe to external calendars	Ability to subscribe to an external calendar in iCalendar (.ics) format	✓	✓
Publish calendar in iCalendar format	Ability to publish/export a calendar in iCalendar (.ics) format	✓	✓
Multi-calendar overlay views	Ability for a user to view multiple calendars overlaid in the same view, which each calendar optionally represented by a different color	✓	✓
Import calendars as ics iCal files	Users can import calendar iCalendars (.ics)	✓	
Mark appointments as private	Appointments can be marked as private or public.	✓	✓
Calendars can be for personal appointments only	Administrators can configure the Calendar feature to be able to create only personal appointments	✓	✓
Search for appointments	Users can search for appointments within their calendars	✓	
HTML Read-Only View for Public Calendars	Public calendars display in HTML read-only format	✓	
<b>Tasks</b>			



Feature	Description	ADV ZWC	STD ZWC
Manage tasks	Add tasks and set the start and due date, set the priority and keep track of the progress and percentage complete	✓	✓
Create task folders	Users can organize task lists into folders	✓	✓
Sort tasks	Users can sort tasks by Status or Due Date	✓	✓
Prioritize tasks	Users can set the priority of tasks to high, normal or low	✓	✓
Tag tasks	Individual tasks can be tagged	✓	✓
Attachments to tasks	Files can be attached to a tasks	✓	✓
<b>Documents</b>			
Create and use Documents feature		✓	
<b>Briefcase</b>			
Create and use Briefcase feature		✓	
<b>Zimlets™</b>			
Use Zimlets		✓	



Feature	Description	ADV ZWC	STD ZWC
<b>Search</b>			
Advanced Search	Advanced interface for building searches	✓	
Cross-context search	Ability to search for a specific item type (Mail, Contacts, Documents, etc.) or across item types	✓	
Wildcard searches	Ability to search using a prefix plus a wildcard	✓	
Continuous search	When using Advanced Search, the search result set updates continuously as search conditions are changed	✓	
Saved Searches	Ability to save searches for subsequent one-click re-execution	✓	
<b>Sharing</b>			
Share with internal users and groups	Ability to share Address Books, Calendars, Task Lists, Document Notebooks, and Briefcase folders with internal users and groups. They can set the permission levels to manage or to view-only.	✓	
Share with External Users	Ability to share Address Books, Calendars, Task Lists, Document Notebooks, and Briefcase folders with external users by assigning a customer password.. Permission level view-only.	✓	
Share with Public	Ability to share Address Books, Calendars, Task Lists, Document Notebooks, and Briefcase folders	✓	



<b>Feature</b>	<b>Description</b>	<b>ADV ZWC</b>	<b>STD ZWC</b>
	with the public. No password is set. Permission level view-only.		
Share Mail Folders	Ability to share Mail Folders with internal users and groups. They can set the permission levels to manage or to view-only	✓	
Link to shared Mail Folders	Users can link to an item that has been shared with them	✓	
Link to shared Address Book	Users can link to an item that has been shared with them	✓	✓
Link to shared Calendar	Users can link to an item that has been shared with them	✓	✓
Link to shared Task List	Users can link to an item that has been shared with them	✓	✓
Link to shared Notebooks	Users can link to an item that has been shared with them	✓	
Link to shared Briefcase Folder	Users can link to an item that has been shared with them	✓	







## Navigating the Standard Zimbra Web Client

When you log into the standard Zimbra Web Client you see a full screen view similar to the one shown below.

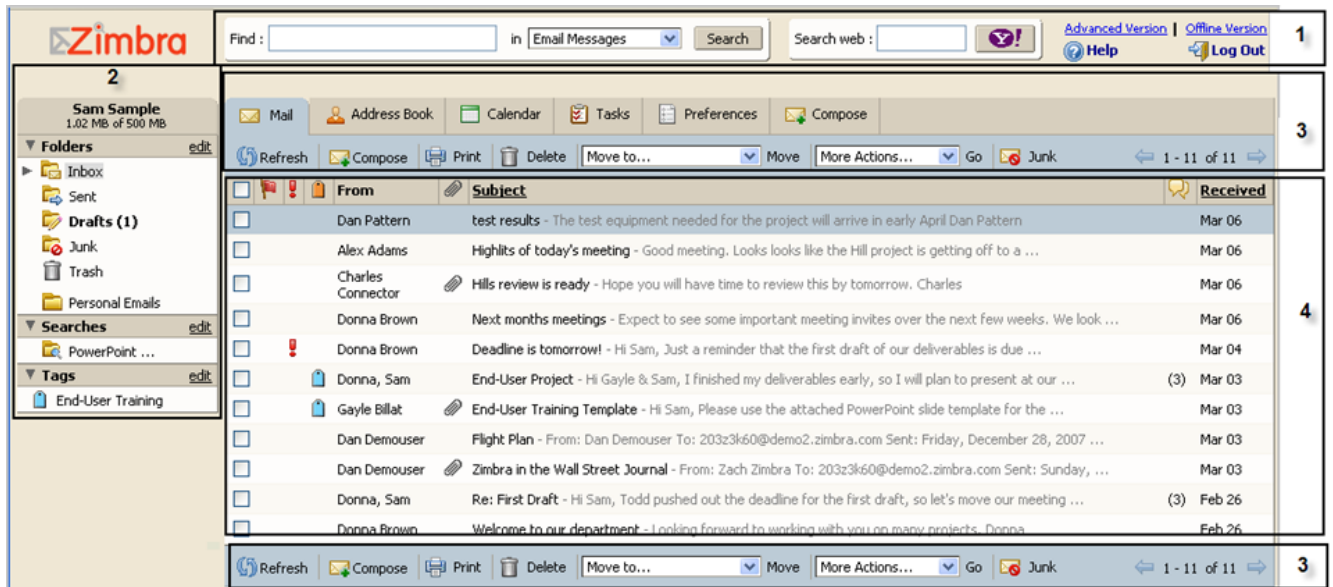
Refer to the following table when viewing the ZWC.



Number	Description
1	<p><b>Window Header.</b> Displays the following:</p> <p>Search Bar</p> <p> <b>Help</b> and  <b>Log Out</b> are displayed on the right</p>
2	<p><b>Overview Pane.</b> Displays the following:</p> <p><b>User Name</b> – the user name under which you logged in</p> <p><b>Quota Display</b> – your mailbox quota</p> <p><b>Folders</b> – including system folders (Inbox, Sent, Draft, Junk, Trash) and folders you created</p>



	<p><b>Searches</b> – search queries that you created and saved for future use while working in the Advance ZWC</p> <p><b>Tags</b> – any tags you have created. Click on a tag to quickly see all messages that are tagged with that tag.</p>
3	<p><b>Toolbar.</b> This bar displays at the top and again under the Content pane and displays the following:</p> <p><b>Tools Tabs</b> – click a tab to access the different ZWC tools available for your account. In this example, Email is open.</p> <p><b>Action Buttons</b> – click an action button to perform a task available for the application you are currently using. The <b>Move to</b> and <b>More Actions</b> fields gives you menu choices available in the application.</p>
4	<p><b>Content Pane.</b> The content of this area changes depending on what application is in use. In the Inbox view, it displays all messages or conversations in your Inbox.</p>

## Move to...

This menu displays the moves that you can make within the application you are in. In this example, In the email application, the message from Dan Pattern is selected and the options for the message are to move to folders in your folder list.

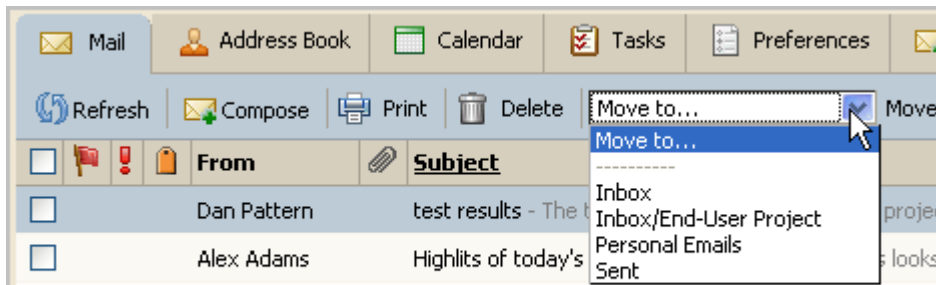

**Move to Options**



## More Action...

This menu displays the different actions that you can make within the application you are in. This example is for when you are in the email application.

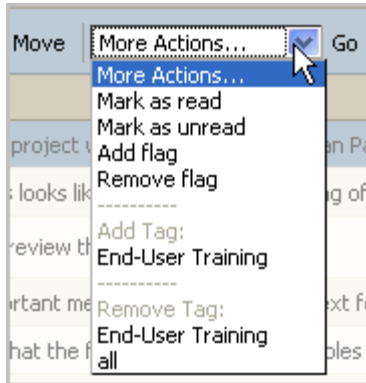

**More Actions**

## Navigation Functions Not Available

The following navigating features are not available with the standard ZWC

Down-arrow menus

Drag and drop

Reading pane

Movable sash

Tool tips

Right-click

Folder information



