

SHURE®

Shure Brothers Incorporated
222 Hartrey Avenue
Evanston IL 60202-3696 U.S.A.

Model PS1A User Guide



The Shure Model PS1A is an ac power supply that provides phantom power for one or two Shure SM81, SM82, SM85, or other condenser microphones. The PS1A can be used with either balanced or unbalanced low-impedance microphone inputs, and is designed to handle both microphone- and line-level signals. It features extremely low noise, hum and RF susceptibility. The PS1A will operate over a wide range of ac voltages, and provides short-circuit-proof operation.

The PS1A contains a power switch, power-on indicator, two each male and female XLR connectors, and an internal voltage selector switch for 240-volt, 50/60 Hz operation. The PS1A is Listed by Underwriters Laboratories, Inc., and is listed by Canadian Standards Association as Certified.

Features

- Phantom powers one or two Shure condenser microphones or similar condenser microphones
- Use with balanced or unbalanced low-impedance microphone inputs
- Low noise, hum and RF susceptibility
- Short-circuit-proof operation
- Operates with both microphone- and line-level signals
- Usable over wide ac voltage ranges
- Three-pin XLR audio connectors
- Lightweight
- Rugged construction
- Listed by Underwriters Laboratories, Inc., and listed by Canadian Standards Association as Certified

SPECIFICATIONS

Type

All-silicon-transistor power supply

Open Circuit Supply Voltage

21.5 ± 1.5 Vdc, regulated (see Figure 1)

Supply Voltage Polarity

Positive (+) on three-socket Microphone connector pins 2 and 3; negative (–) on pin 1 and case

Typical Supply Operating Conditions (each channel)

20 V at 1.5 mA (with Shure SM81 or SM85); 15 V at 8 mA (with Shure SM82)

Power Supply Resistors

1.69 k ± 1% (two per channel; see Figure 1)

Frequency Response

+0/– 0.2 dB, 20-20,000 Hz (with SM81 or SM85 and 1k load)

Maximum Operating Level

Greater than ± 24 dBm

Short Circuit Supply Current

25 mA each channel (pins 2 and 3 to pin 1)

Hum and Noise (20 Hz-20 kHz, unweighted)

Common Mode: –90 dBV maximum
Differential Mode: –115 dBV maximum

Noise

300 Hz-20 kHz, unweighted
Common Mode: 100 dBV maximum
Differential Mode: –115 dBV maximum
A-weighted, measured with true rms voltmeter
Differential Mode: –131 dBV maximum

Crosstalk

–115 dB or less

Phasing

Corresponding pins of all connectors are in phase

Operating Voltage

90-132 Vac, 50/60 Hz or 180-264 Vac, 50/60 Hz (internal switch-selectable); power consumption 3 watts maximum

Temperature Range

Operating: –7° to 57° C (20° to 135° F)
Storage: –29° to 71° C (–20° to 160° F)

Connectors

Professional audio (XLR): male (Output) and female (Microphone)

Dimensions

72 mm H x 156 mm W x 150 mm D (2-27/32 in. x 6-5/32 in. x 5-29/32 in.)

Weight

1.25 kilograms (2 lb 12 oz)

Construction

Aluminum front panel with steel cover; finished in gray enamel

Certifications

Listed by Underwriters Laboratories, Inc.; listed by Canadian Standards Association as Certified

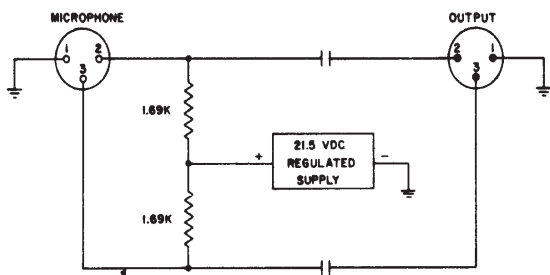

SIMPLIFIED EQUIVALENT CIRCUIT
(ONE CHANNEL)
FIGURE 1

OPERATION

Installation

WARNING

To reduce the risk of fire or electric shock, do not expose this appliance to rain or extreme moisture.

The PS1A can be installed anywhere along the microphone line between the microphone and the mixer, audio console, amplifier or tape recorder, and convenient to an ac power source. Connect one or two SM81, SM82, SM85 or other Shure condenser microphones to the PS1A Microphone connectors. NOTE: When using other manufacturer's condenser microphones with the PS1A, verify that the voltage and resistance requirements are compatible.

Connect a second cable from each PS1A Output connector to a mixer input connector.

The design of the PS1A permits the simultaneous operation of both a microphone-level and a line-level condenser microphone.

The PS1A phantom powering system uses the balanced audio cable pair to carry the supply current to the microphone. The cable shield is used as a ground return. Use only high-quality microphone cables, as intermittent shorts between broken shield wires and the balanced conductors will interrupt the current, causing large noise transients in the system. Avoid ground loops that may occur due to connector shells or the microphone case touching other metal objects. Incorporate generally accepted audio grounding practices. Note that a PS1A can be used with either balanced or unbalanced low-impedance microphone inputs.

Power Connections

Connect the ac power plug to a grounded 90 to 132 Vac, 50/60 Hz power source. Turn on the Power switch. The LED lamp above the power switch will light when power is applied. If the PS1A is to be operated from a 180 to 264 Vac, 50/60 Hz power source, the modification described in the next section must be performed.

SERVICE

WARNING

Voltages in this equipment are hazardous to life. Refer servicing to qualified service personnel.

240V Operation

The PS1A is designed for operation from either a 90 to 132 Vac, 50/60 Hz or a 180 to 264 Vac, 50/60 Hz ac power source. The operating voltage is selected by an internal switch, and the unit is supplied with the switch set for 90 to 132 Vac operation.

For operation from a 180 to 264 Vac, 50/60 Hz power source, follow these steps.

1. Unplug the ac line cord and remove the two self-tapping screws securing the top cover.
2. Remove the top cover.
3. Locate the voltage selector switch and move it to the 240V position.
4. Replace the line cord (if necessary) with one designed for the new ac source. If the PS1A is to be used outside the U.S. and Canada, local regulations may require replacing the line cord with one having wire insulation colors as follows:

| | "Live" or "Hot" | Neutral | Earth or Ground |
|--------------|-----------------|---------|-----------------|
| U.S., Canada | Black | White | Green |
| Europe | Brown | Blue | Green/Yellow |

5. Replace the top cover and mark the rear panel to reflect the new operating voltage.

REPLACEMENT PARTS LIST

| REFERENCE DESIGNATION | DESCRIPTION | SHURE PART OR COMERCIAL ALTERNATE* |
|-------------------------|---|------------------------------------|
| C101-C104 | Capacitor, Electrolytic, 100 μ F, 50V | Sprague 503D107F050PD |
| C105 | Capacitor, Electrolytic, 470 μ F, 50V | Sprague 503D477F050QG |
| C106 | Capacitor, Electrolytic, 220 μ F, 50V | Sprague 503D227F050QE |
| C107 | Capacitor, Electrolytic, 4.7 μ F, 50V | Sprague 475M063AA3D |
| D101-D102, D105-D108 | Diode, Silicon Rectifier, 100V, 1/2A | Shure RKC21;** Motorola 1N4002 |
| D104 | Zener Diode, 22V, 5%, 250 mW | Motorola 1N4115 |
| J101-J102 | Connector, Female XLR, Microphone | Switchcraft D3F |
| J103-J104 | Connector, Male XLR, Output | Switchcraft D3M |
| Q101 | Transistor, Silicon, PNP | Shure 86A353; Motorola MPS-U52 |
| Q102 | Transistor, Silicon, NPN | Shure 86C349; Motorola 2N5088 |
| R101-R104 | Resistor, Metal Film, 1.69 k, 1/2W, 1% | TRW/IRC T0-60 |
| R109 | Resistor, Metal Oxide, 47, 1/2W | RCA 830047 |
| S1 | Switch, Slide, DPDT, Voltage Selector | None |
| S2 | Switch, Slide, DPDT, Power | None |
| T1 | Transformer, Power | None |
| W1 | Line Cord, 3-Conductor, 2.7 m (7 ft) | Shure 95A8015 |

*Parts listed as "None" should be ordered from Shure Brothers Inc. listing product model number, reference designation and part description.

**Supplied in multiples of four only.

PRINTED CIRCUIT BOARDS

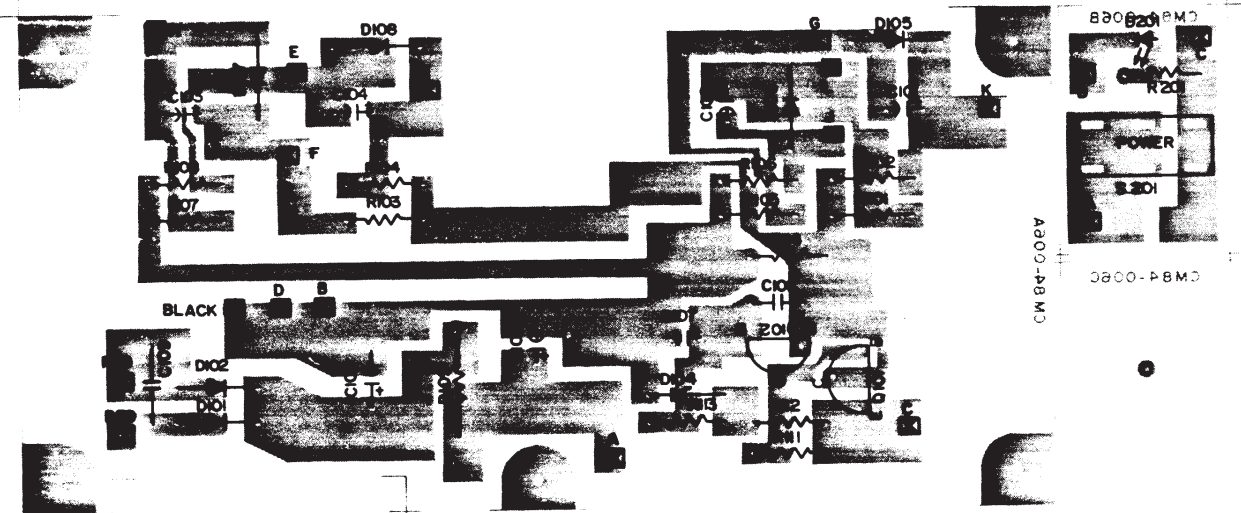

CIRCUIT DIAGRAM

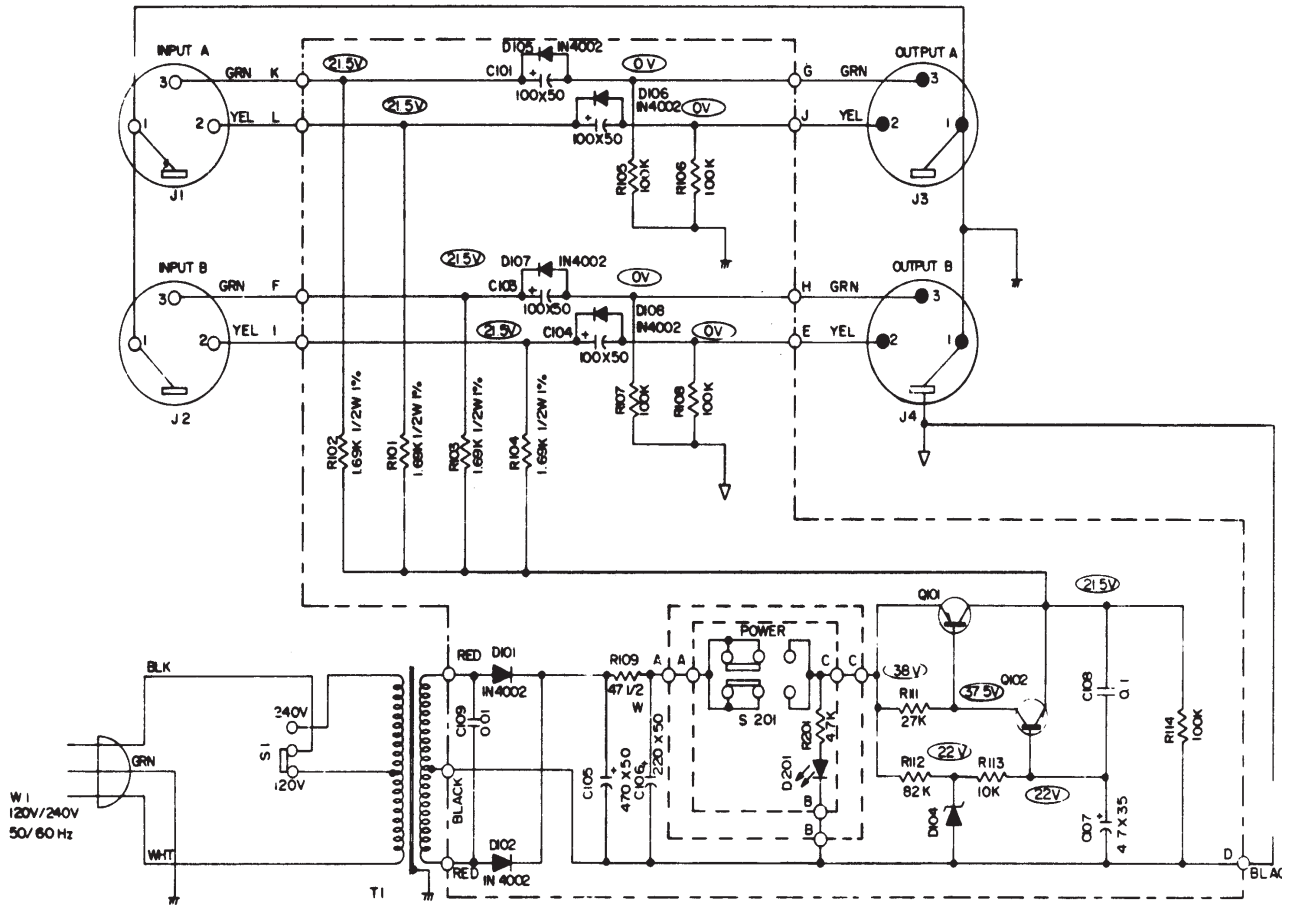

NOTES:

1. ALL CAPACITORS IN MFD AND 50V OR MORE UNLESS OTHERWISE SHOWN.
ALL ELECTROLYTIC CAPACITORS SHOWN IN MFD X VOLTS
2. RESISTORS TO BE $\pm 5\%$ 1/4 WATT UNLESS OTHERWISE SPECIFIED
3. $\text{---}\text{---}\text{---}$ MARKING CHASSIS GROUND ∇ MARKING P.C. BOARD GROUND
4. --- DENOTES D.C. VOLTAGE ALL VOLTAGES MEASURED WITH AC LINE = 120V, 60 Hz D.C. VOLTAGES MEASURED WITH 10 MEGOHM VTVM JACKS J1, J2, J3 AND J4 UNTERMINATED VALUES ARE TYPICAL AND MAY VARY $\pm 15\%$ VALUES MARKED WITH * MAY VARY $\pm 5\%$