



FUTURE

MOBILITY HEALTHCARE INC.

innovative seating and mobility solutions



OWNERS MANUAL

1 CONTACT INFORMATION

FUTURE MOBILITY HEALTHCARE INC. APPRECIATES YOUR FEEDBACK

Supplier: Please give this manual to the user of the wheelchair.

User: Please read this entire manual before using this wheelchair.

Thank you for choosing Future Mobility Healthcare Inc.
If you have any questions please do not hesitate to write or call us
at the address and telephone number below:

Future Mobility Healthcare Inc.

Customer Service Canada
3223 Orlando Dr.

Mississauga ON L4V 1C5

Phone: (888) 737-4011 or (905) 671-1661

Fax: (905) 671-3377

e-mail: customerservice@futuremobility.ca

www.futuremobility.ca

2 TABLE OF CONTENTS

TABLE OF CONTENTS

1	CONTACT INFORMATION	2
2	TABLE OF CONTENTS.....	3
3	PARTS OF THE WHEELCHAIR.....	5
4	NOTICE – READ BEFORE USE	6
	CHOOSE THE CORRECT CHAIR AND OPTIONS	6
	REVIEW THIS MANUAL OFTEN	6
	WARNING.....	6
5	GENERAL WARNINGS.....	7
	USER WEIGHT LIMIT	7
	WEIGHT TRAINING	7
	GETTING TO KNOW YOUR CHAIR.....	7
	TO REDUCE THE RISK	7
	SAFETY CHECKLIST	7
	CHANGES AND ADJUSTMENTS.....	8
	GROUND TERRAIN.....	8
	CENTER OF GRAVITY	8
	WHEELIES.....	8
	ROLLING BACKWARDS.....	8
	REACHING OR LEANING.....	9
	RAMPS AND SLOPES.....	9
	TRANSFERS	9
6	ATTENDANT WARNINGS	11
	TILTING THE WHEELCHAIR.....	11
	DESCENDING A CURB	11
	CLIMBING A CURB.....	11
	DESCENDING STAIRS.....	11
7	COMPONENT WARNINGS.....	13
	ANTI-TIP WHEELS	13

	ARMRESTS	13
	BACK CANES	13
	FASTENERS.....	13
	FOOTRESTS	13
	POSITIONING BELTS	14
	QUICK-RELEASE AXLES.....	14
	REAR WHEEL AXLES	14
	REAR WHEEL LOCKS.....	15
8	WHEELCHAIR SET-UP AND ADJUSTMENTS	16
	HEIGHT ADJ. T-STYLE PIN RELEASE ARM	16
	HEIGHT ADJ. T-STYLE KNOB RELEASE ARM.....	17
	HEIGHT ADJ. FLIP-BACK ARM	18
	CENTER PIVOT SWINGAWAY AND HANGER	19
	PIN STYLE SWINGAWAY AND HANGER	20
	DUAL SWINGAWAY AND HANGER.....	21
	DUAL ELEVATING LEGREST AND HANGER	22
	CASTER AND FORK ASSEMBLY	23
	REAR WHEEL AXLE (QUICK RELEASE)	24
	FRONT SEAT TO FLOOR SET-UP CHART	25
	REAR WHEEL AXLE MOUNT.....	27
	REAR WHEEL BRACKET MOUNT	28
	REAR ANTI-TIPS	29
	BACKREST AND STROLLER HANDLE.....	30
	TILT MECHANISM.....	32
	TRIGGER CABLE ADJUSTMENT	33
	WHEEL LOCKS	34
	CHAIR WIDTH ADJUSTMENT.....	36
	SEAT DEPTH ADJUSTMENT	40
	CUSHION INSTALLATION	40
	TIE-DOWNS.....	41
9	TROUBLE SHOOTING.....	42
10	MAINTENANCE.....	43
	SAFETY INSPECTION CHECKLIST.....	43

GENERAL MAINTENANCE	45
SERVICE AND REPAIR	45
CLEANING YOUR CHAIR.....	45
11 WARRANTY	47
LIFETIME	47
FOR TWO (2) YEARS	47
FOR ONE (1) YEAR	47
FOR (90) DAYS.....	47
LIMITATIONS.....	47
WARRANTY PROCEDURES.....	47

3 PARTS OF THE WHEELCHAIR

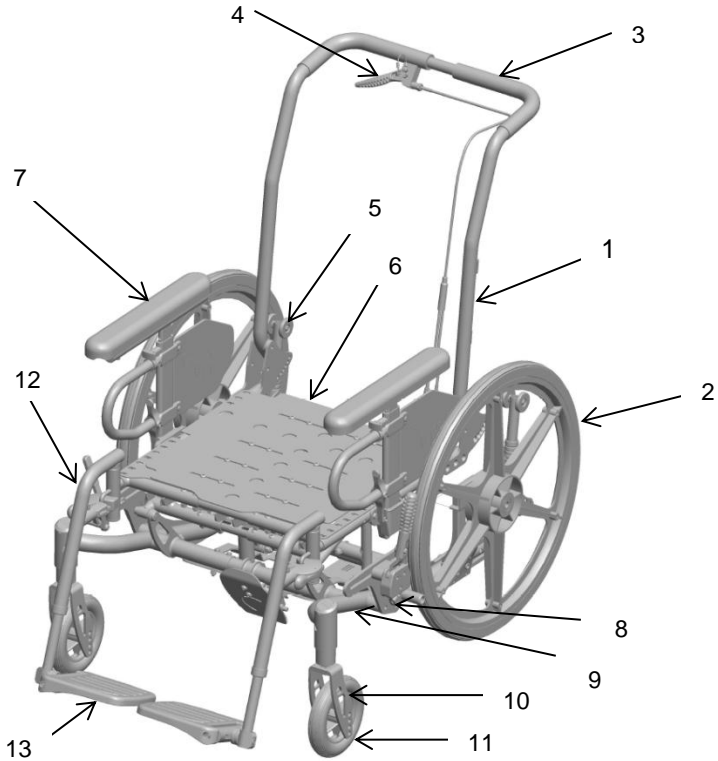

- 1. Back Post
- 2. Rear Wheel
- 3. Stroller Bar
- 4. Trigger Handle and Cable
- 5. Anti-tip
- 6. Seatpan
- 7. T-Style Armrest
- 8. Wheel Lock
- 9. Lower Frame
- 10. Caster Fork
- 11. Caster Wheel
- 12. Swing Away Footrest
- 13. Composite Footplate

4 NOTICE – READ BEFORE USE

CHOOSE THE CORRECT CHAIR AND OPTIONS

Future Mobility Healthcare Inc. provides a choice of many wheelchair styles to meet the requirements of the wheelchair user. However, the final selection of the wheelchair and its options rests solely with you and your health care advisor. Choosing the best chair will depend on such things as:

1. The level of your disability, strength, balance and coordination.
2. The places and terrain that you are likely to use your chair.
3. The need for options for your safety and comfort (such as anti-tip tubes, positioning belts, or special seating systems).

REVIEW THIS MANUAL OFTEN

Before using this chair you, and each person who may assist you, should read this entire manual and make sure to follow all instructions. Review the warnings often.

WARNING

The term “**WARNING**” are hazards or unsafe practices that may cause **severe injury or death** to you or to other persons.

5 GENERAL WARNINGS

USER WEIGHT LIMIT



WARNING

NEVER exceed the weight limit of 300 pounds for a combined weight of rider and items carried. If you do exceed the limit, damage to your chair, tip-over or loss of control may occur and cause severe injury to the rider or others.

WEIGHT TRAINING



WARNING

NEVER use this chair for weight training if total weight (rider plus equipment) exceeds 300 pounds. If you do exceed the limit, damage to your chair, tip-over or loss of control may occur and cause severe injury to the rider or others.

GETTING TO KNOW YOUR CHAIR



WARNING

Every wheelchair is different. Take the time to learn the feel of this chair before you begin riding. Start slowly, with easy, smooth strokes. If you are used to a different chair, you may use too much force and tip over. If you use too much force, damage to your chair, a fall, tip over or loss of control may occur and cause severe injury to the rider or others.

TO REDUCE THE RISK



WARNING

1. BEFORE riding, you should be trained in the safe use of this chair by your health care advisor.
2. Practice bending, reaching and transfers until you know the limit of your ability. Have someone help you until you know what can cause a fall or tip-over and how to avoid doing so.
3. Be aware that you must develop your own methods for safe use best suited to your level of function and ability.
4. NEVER try a new maneuver on your own until you are sure you can do it safely.
5. Get to know the areas where you plan to use your chair. Look for hazards and learn how to avoid them.
6. Use anti-tip tubes unless you are a skilled rider of this chair and are sure you are not at risk to tip over.

SAFETY CHECKLIST



WARNING

Before each use of your chair:

1. Make sure the chair rolls easily and that all parts work smoothly. Check for noise, vibration, or a change in ease of use. (They may indicate low tire pressure, loose fasteners, or damage to your chair).
2. Repair any problem. Your authorized supplier can help you find and correct the problem.
3. Check to see that both quick-release rear axles are locked. When locked, the axle button will “pop out” fully.

CHANGES AND ADJUSTMENTS



WARNING

1. If you modify or adjust this chair, it may increase the risk of a tip-over UNLESS you make other changes as well.
2. **Consult your authorized supplier BEFORE you modify or adjust your chair, or contact Future Mobility Healthcare.**
3. We recommend that you use anti-tip tubes until you adapt to the change, and are sure you are not at risk to tip over.
4. Unauthorized modifications or use of parts not supplied or approved by Future Mobility Healthcare may change the chair structure.
 - A. This will void the warranty and may cause a safety hazard.

GROUND TERRAIN



WARNING

1. Your chair is designed for use on firm, even surfaces such as concrete, asphalt and indoor floors and carpeting.
2. Do not operate your chair in sand, loose soil or over rough terrain. This may damage wheels or axles, or loosen fasteners of your chair.

CENTER OF GRAVITY



WARNING

The point where this chair will tip forward, back, or to the side depends on its center of gravity and stability.

How your chair is set up, the options you select and the changes you make may affect the risk of a fall or tip-over.

1. The Most Important Adjustments Are:
 - a. The position of the rear wheels. The more you move the rear wheels forward, the more likely your chair will tip over backward.
 - b. The position of the carriage.
2. The Center Of Gravity Is Also Affected By:
 - a. A change in the set-up of your chair, including:
 - i. The seat height and seat angle.
 - ii. Backrest angle.
 - b. A change in your body position, posture or weight distribution.
 - c. Riding your chair on a ramp or slope.
 - d. The use of a back pack or other options, and the amount of added weight.

WHEELIES



WARNING

Because of the ability to adjust the center of gravity and changes in center of gravity that will result from operating the tilt in space feature of this chair, as a user, do not perform wheelies in this wheelchair.

Doing a "wheelie" means: balancing on the rear wheels of your chair, while the front casters are in the air. It is dangerous to do a "wheelie" as a fall or tip-over may occur.

ROLLING BACKWARDS



WARNING

Use extra care when you move your chair backward. Your chair is most stable when you propel yourself forward.

You may lose control or tip over if one of the rear wheels hits an object and stops rolling.

1. Propel your chair slowly and smoothly.
2. If your chair has anti-tip tubes, make sure to lock them in place.
3. Stop often and check to be sure your path is clear.

REACHING OR LEANING



WARNING

If you reach or lean it will affect the center of balance of your chair. This may cause you to fall or tip over. When in doubt, ask for help or use a device to extend your reach.

1. NEVER reach or lean if you must shift your weight sideways or rise up off the seat.
2. NEVER reach or lean if you must move forward in your seat to do so. Always keep your buttocks in contact with the backrest.
3. NEVER reach with both hands (you may not be able to catch yourself to prevent a fall if the chair tips).
4. NEVER reach or lean to the rear unless your chair has anti-tip tubes locked in place.
5. DO NOT reach or lean over the top of the seat back. This may damage one or both backrest tubes and cause you to fall.
6. If You Must Reach Or Lean:
 - a. Do not lock the rear wheels. This creates a tip point and makes a fall or tip-over more likely.
 - b. Do not put pressure on the footrests.
 - c. Move your chair as close as you can to the object you wish to reach.

RAMPS AND SLOPES



WARNING

Riding on a slope, which includes a ramp or side hill, will change the center of balance of your chair. Your chair is less stable when it is at an angle. Anti-tip tubes may not prevent a fall or tip-over.

1. Do not use your chair on a slope steeper than 10%.
2. Always go as straight up and as straight down as you can. (Do not “cut the corner” on a slope or ramp.)
3. Do not turn or change direction on a slope.
4. Always stay in the CENTER of the ramp. Make sure ramp is wide enough that you are not at risk that a wheel may fall over the edge.
5. Do not stop on a steep slope. If you stop, you may lose control of your chair.
6. NEVER use rear wheel locks to try to slow or stop your chair. This is likely to cause your chair to veer out of control.
7. Beware Of:
 - a. Wet or slippery surfaces.
 - b. A change in grade on a slope (or a lip, bump or depression).
 - c. A drop-off at the bottom of a slope. A drop-off of as small as 3/4 inch can stop a front caster and cause the chair to tip forward.

TRANSFERS



WARNING

It is dangerous to transfer on your own. It requires good balance and agility. Be aware that there is a point during every transfer when the wheelchair seat is not below you. To Avoid A Fall:

1. Work with your health care advisor to learn safe methods.
 - a. Learn how to position your body and how to support yourself during a transfer.
 - b. Have someone help you until you know how to do a safe transfer on your own.
2. Lock the rear wheels before you transfer. This keeps the rear wheels from rolling.
3. Make sure to keep pneumatic tires properly inflated. Low tire pressure may allow the rear wheel locks to slip.
4. Move your chair as close as you can to the seat you are transferring to. If possible, use a transfer board.
5. Rotate the front casters until they are as far forward as possible.
6. If you can, remove or swing footrests out of the way.
 - a. Make sure your feet do not catch in the space between the footrests.
 - b. Avoid putting weight on the footrests as this may cause the chair to tip.

6 ATTENDANT WARNINGS

TILTING THE WHEELCHAIR



WARNING

In preparation to operate the tilt:

1. Always verify that the arms of the rider are stable on the armrests or within the armrests.
2. Always verify that the legs of the rider are stable on the footrest/ legrest.
3. Never place hands, feet or foreign objects into the tilt mechanism.
4. Never push or propel the chair with the seat tilted in a forward position.
5. Never add chair accessories that are not specifically designed for the wheelchair.
6. Never exceed a tilted position that aligns the backrest parallel to the ground.

DESCENDING A CURB



WARNING

Follow these steps to help a rider descend a curb or single step going BACKWARD:

1. Stay at the rear of the chair.
2. Several feet before you reach the edge of the curb or step, turn the chair around and pull it backward.
3. While looking over your shoulder, carefully step back until you are off the curb or stair and standing on the lower level.

4. Pull the chair toward you until the rear wheels reach the edge of the curb or step. Then allow the rear wheels to slowly roll down onto the lower level.
5. When the rear wheels are safely on the lower level, tilt the chair back to its balance point. This will lift the front casters off the curb or step.
6. Keep the chair in balance and take small steps backward.
7. Turn the chair around and gently lower front casters to the ground

CLIMBING A CURB



WARNING

Follow these steps to help the rider climb a curb or single step going FORWARD:

1. Stay behind the chair.
2. Face the curb and tilt the chair up on the rear wheels so that the front casters clear the curb or step.
3. Move forward, placing the front casters on the upper level as soon as you are sure they are past the edge.
4. Continue forward until the rear wheels contact the face of the curb or step. Lift and roll the rear wheels to the upper level.

DESCENDING STAIRS



WARNING

1. Use at least two attendants to move a chair and rider down stairs.
2. Move the chair and rider FORWARD down the stairs.

3. The person at the rear is in control. He or she tilts the chair to the balance point of the rear wheels and rolls it to the edge of the top step.
4. A second attendant stands on the third step from the top and grasps the hanger receiver or frontmost part of the seat rail. He or she lowers the chair one step at a time by letting the rear wheels roll over the stair edge.
5. The attendants move to the next stair down. Repeat for each stair, until you reach the landing.

7 COMPONENT WARNINGS

ANTI-TIP WHEELS



WARNING

Anti-tip wheels can help keep your chair from tipping over backward in most normal conditions.

1. Future Mobility Healthcare Recommends Use Of Anti-Tip Tubes:
 - a. UNLESS you are a skilled rider of this chair and are sure you are not at risk to tip over.
 - b. Each time you modify or adjust your chair. The change may make it easier to tip backward. Use anti-tip tubes until you adapt to the change, and are sure you are not at risk to tip over.
2. When locked in place (in the “down” position) anti-tip tubes should be BETWEEN 1 1/2 and 2 inches off the ground.
 - a. If set too HIGH, they may not prevent a tip-over.
 - b. If set too LOW, they may “hang up” on obstacles you can expect in normal use. If this occurs, you may fall or your chair may tip over.
3. Keep Anti-Tip Tubes Locked In Place UNLESS:
 - a. You have an attendant, or
 - b. You have to climb or descend a curb, or overcome an obstacle, and can safely do so without them. At these times, make sure anti-tip tubes are up, out of the way.

ARMRESTS



WARNING

Armrests will not bear the weight of this chair.

1. NEVER lift this chair by its armrests. They may come loose or break.
2. Lift this chair only by non-detachable parts of the main frame.

BACK CANES



WARNING

Always keep fingers away from the locking mechanism located at the bottom of the back canes when folding the back down or pulling it back up.

FASTENERS



WARNING

Many of the screws, bolts and nuts on this chair are special high-strength fasteners. Use of improper fasteners may cause your chair to fail.

1. ONLY use fasteners provided by an authorized supplier (or ones of the same type and strength, as indicated by the markings on the heads).
2. Over- or under-tightened fasteners may fail or cause damage to chair parts.
3. If bolts or screws become loose, tighten them as soon as you can.

FOOTRESTS



WARNING

Footrests will not bear the weight of this chair

1. At the lowest point, footrests should be AT LEAST 2 INCHES off the ground. If set too LOW, they may “hang up” on obstacles you can expect to find in normal use. This may cause the chair to stop suddenly and tip forward.
2. To Avoid A Trip Or Fall When You Transfer:
 - a. Make sure your feet do not “hang up” or get caught in the space between the footrests.
 - b. Avoid putting weight on the footrests, as the chair may tip forward.
3. NEVER lift this chair by the footrests. Footrests detach and will not bear the weight of this chair. Lift this chair only by non-detachable parts of the main frame.

POSITIONING BELTS



WARNING

Use positioning belts ONLY to help support the rider’s posture. Improper use of these belts may cause severe injury to or death of the rider.

1. Make sure the rider cannot slide down in the wheelchair seat.
2. If this occurs, the rider may suffer chest compression or suffocate due to pressure from the belts.
3. The belts must be snug, but must not be so tight that they interfere with breathing. You should be able to slide your open hand, flat, between the belt and the rider.
4. A pelvic wedge or a similar device can help keep the rider from sliding down in the seat. Consult with the rider’s doctor, nurse or therapist to find out if the rider needs such a device.
5. Use positioning belts only with a rider who can cooperate.

6. Make sure the rider can easily remove the belts in an emergency.
7. NEVER Use Positioning Belts:
 - a. As a patient restraint. A restraint requires a doctor’s order.
 - b. On a rider who is comatose or agitated.
 - c. As a motor vehicle restraint. In an accident or sudden stop the rider may be thrown from the chair. Wheelchair seat belts will not prevent this, and further injury may result from the belts or straps.

QUICK-RELEASE AXLES



WARNING

1. Do not use this chair UNLESS you are sure that both quick-release rear axles are locked. An unlocked axle may come off during use and cause a fall.
2. An axle is not locked until the quick-release button pops out fully. An unlocked axle may come off during use, resulting in a fall, tip-over or loss of control and cause severe injury to the rider or others.

REAR WHEEL AXLES



WARNING

A change in set-up of the rear wheels will affect the center of balance of your chair.

1. The farther you move the rear axles FORWARD, the more likely it is that your chair will tip over backward.

2. Consult your doctor, nurse or therapist to find the best rear axle set-up for your chair. Do not change the set-up UNLESS you are sure you are not at risk to tip over.
3. Adjust the rear wheel locks after you make any change to the rear axles.
 - a. If you fail to do so, the locks may not work.
 - b. Make sure wheel locks are embedded in tires at least 1/8 inch when locked.

REAR WHEEL LOCKS



WARNING

Rear wheel locks are **NOT** designed to slow or stop a moving wheelchair. Use them only to keep the rear wheels from rolling when your chair is at a complete stop.

1. NEVER use rear wheel locks to try to slow or stop your chair when it is moving. Doing so may cause you to veer out of control.
2. To keep the rear wheels from rolling, always set both rear wheel locks when you transfer to or from your chair.
3. Low pressure in a rear tire may cause the wheel lock on that side to slip and may allow the wheel to turn when you do not expect it.
4. Make sure wheel locks are embed in tires at least 1/8 inch when locked. If you fail to do so, the locks may not work.

8 WHEELCHAIR SET-UP AND ADJUSTMENTS

HEIGHT ADJ. T-STYLE PIN RELEASE ARM 1

1. Installation

- a. Slide the main armpost into the receiver mounted to the seat frame tube.
- b. The armrest will automatically lock into place, engaging the release lever.

2. Height Adjustment

- a. Pull the release pin lever to the outward position.
- b. Slide armrest pad up or down to desired height.
- c. Return release pin to the locked position against armpost.
- d. Push arm pad until upper armpost locks firmly into place.

3. Removing Armrest

- a. Press the release lever to disengage and remove the armrest.

4. Frame Adjustment Position

- a. Remove armrest from chair.
- b. Remove the two screws holding the receiver in place.
- c. Move the receiver to the required position.
- d. Replace the two screws holding the receiver.
- e. Re-install the armrest into the receiver.

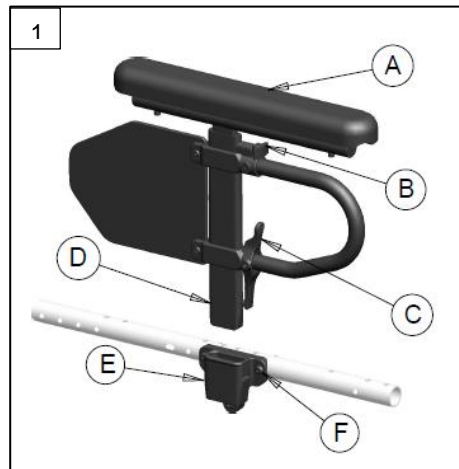

- A. Armtop Pad
- B. Release Pin
- C. Release Lever
- D. Armpost
- E. Receiver
- F. Mounting Screws

HEIGHT ADJ. T-STYLE KNOB RELEASE ARM

2

1. Installation

- Slide the main armpost into the receiver mounted to the seat frame tube.
- The armrest will automatically lock into place, engaging the release lever.

2. Height Adjustment

- Turn the release knob counter-clock wise to disengage the ball pin.
- Slide armrest pad up or down to desired height. Listen for the “clicks” to verify position.
- Turn the release knob clock wise to lock the armpost.
- Push arm pad to check that it is locked firmly into place.

3. Removing Armrest

- Press the release lever to disengage and remove the armrest.

4. Frame Adjustment Position

- Remove armrest from chair.
- Remove the two screws holding the receiver in place.
- Move the receiver to the required position.
- Replace the two screws holding the receiver.
- Re-install the armrest into the receiver.

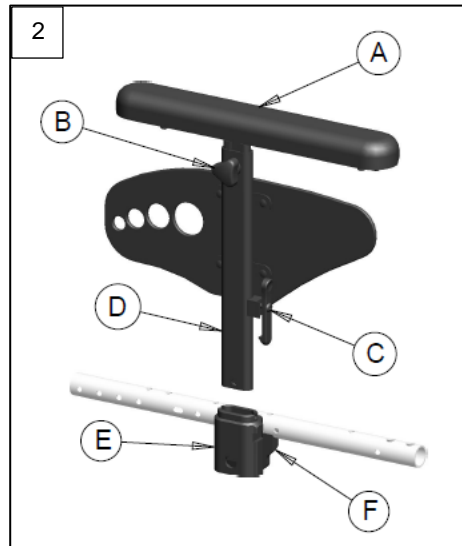

- Armtop Pad
- Release Knob
- Release Lever
- Armpost
- Receiver
- Mounting Screws

HEIGHT ADJ. FLIP-BACK ARM

3

1. Engaging and Disengaging Flip-back Arm

- To disengage, press and hold the release lever (C) while pulling up on the arm body.
- Flip the armrest back; it remains attached to the rear pivot mount.
- To reattach move the armrest down into place.
- Press down until the release lever (C) locks into the receiver (D).

2. Height Adjustment

- Pull the release knob (B) out to disengage the ball pin.
- Slide armrest pad up or down to desired height.
- Release the release knob to lock the armpost.
- Push arm pad to check that it is locked firmly into place.

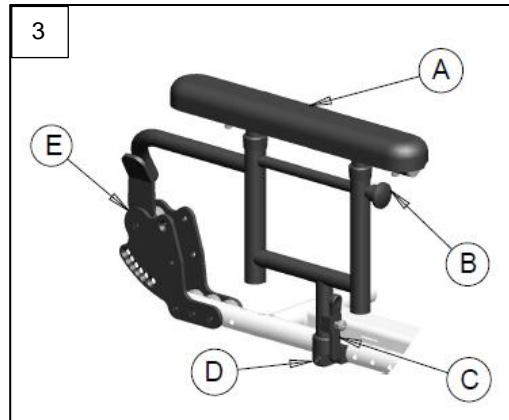

CENTER PIVOT SWINGAWAY AND HANGER

4

1. Installation

- a. Position the center pivot of the swingaway footrest (C) onto the hanger (B) with the swingaway footrest facing out from the wheelchair.
- b. Swing the footrest inwards such that the swingaway latch (A) 'clicks' into place onto the U-bolt.

2. Removal

- a. To remove the footrest, pull outward onto the handle latch (A) releasing the mechanism from the U-bolt and swing the footrest outwards.
- b. Pull up on the footrest to remove from wheelchair.

3. Height Adjustment

- a. Remove bolt (D) which holds the extension tube in place.
- b. Slide the footrest extension tube up or down to the desired height. Note a minimum of 2" should be kept between the footplate (E) and the floor.
- c. Re-install and tighten the bolt (D) in place.

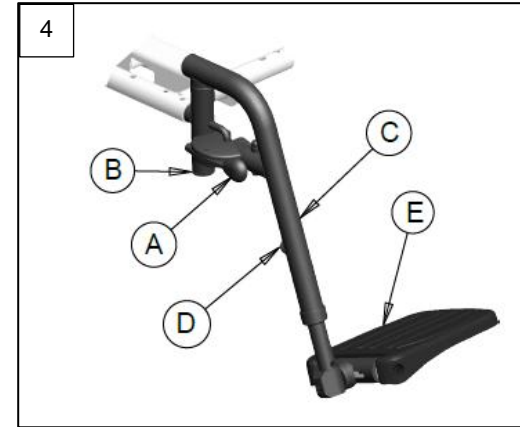

PIN STYLE SWINGAWAY AND HANGER

5

1. Installation

- a. Line up the two pivot holes of the swingaway footrest (C) onto the hanger (B) with the swingaway footrest facing out from the wheelchair.
- b. Swing the footrest inwards such that the swingaway latch (A) 'clicks' into place onto the hanger.

2. Removal

- a. To remove the footrest, push inward onto the handle latch (A) releasing the mechanism from the hanger and swing the footrest outwards.
- b. Pull up on the footrest to remove from wheelchair.

3. Height Adjustment

- a. Remove bolt (D) which holds the extension tube in place.
- b. Slide the footrest extension tube up or down to the desired height. Note a minimum of 2" should be kept between the footplate (E) and the floor.
- c. Re-install and tighten the bolt (D) in place.

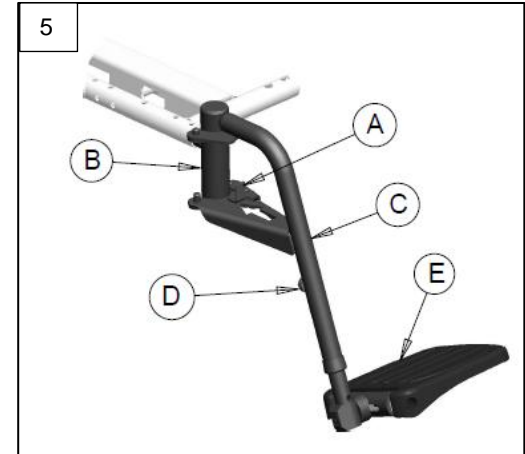

DUAL SWINGAWAY AND HANGER

6

1. Installation

- a. Position the center pivot of the swingaway footrest (C) onto the hanger (B) with the swingaway footrest facing out from the wheelchair.
- b. Swing the footrest inwards such that the swingaway latch (A) 'clicks' into place onto the hanger block.

2. Removal

- a. To remove the footrest, pull up onto the handle latch (A) releasing the mechanism from the hanger and swing the footrest outwards or inwards.
- b. Pull up on the footrest to remove from wheelchair.

3. Height Adjustment

- a. Remove bolt (D) which holds the extension tube in place.
- b. Slide the footrest extension tube up or down to the desired height. Note a minimum of 2" should be kept between the footplate (E) and the floor.
- c. Re-install and tighten the bolt (D) in place.

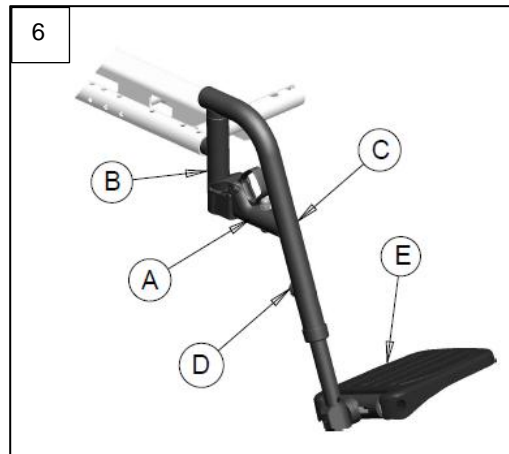

DUAL ELEVATING LEGREST AND HANGER

7

1. Installation

- Position the center pivot of the elevating legrest (C) onto the hanger (B) with the elevating footrest facing out from the wheelchair.
- Swing the elevating legrest inwards such that the swingaway latch (A) 'clicks' into place onto the hanger block.

2. Removal

- To remove the elevating legrest, pull up onto the handle latch (A) releasing the mechanism from the hanger and swing the elevating legrest outwards or inwards.
- Pull up on legrest to remove from wheelchair.

3. Height Adjustment

- Remove bolt (D) which holds the extension tube in place.
- Slide the footrest extension tube up or down to the desired height. Note a minimum of 2" should be kept between the footplate (E) and the floor.
- Re-install and tighten the bolt (D) in place.

4. Elevation Adjustment

- Turn the release knob (F) counter-clock wise to disengage the ball pin.
- Move the legrest up or down to desired height. Listen for the "clicks" to verify position.
- Turn the release knob clock wise to lock the position.

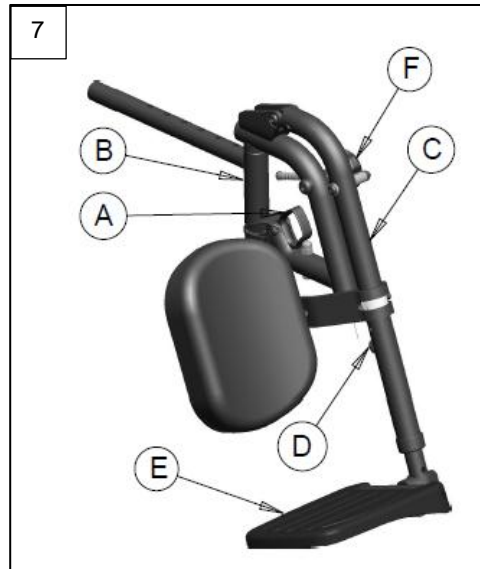

7

CASTER AND FORK ASSEMBLY

8

1. Installation

- Remove dust cover (A) from caster housing. Gently pry off cover using a back and forth motion.
- Remove bolt (D) from the caster housing (C).
- Caster assembly holds one nut (B) and one washer (immediately below the nut). Remove nut and washer.
- Insert caster stem spacer (E) into caster housing (C). Size will depend on required STF (See Chart).
- Insert caster stem and fork (F) (G) into caster spacer (E) and place washer on stem.
- Replace nut (B) on caster stem and tighten until all play is removed; then loosen approximately 1/8 turn, allowing for free rotation.
- Replace dust cover to caster housing.

2. Height Adjustment

- Loosen and remove bolt (H).
- Set axle at desired height using pre-set holes in the fork.
- Replace and tighten bolt.
- Repeat on other side.

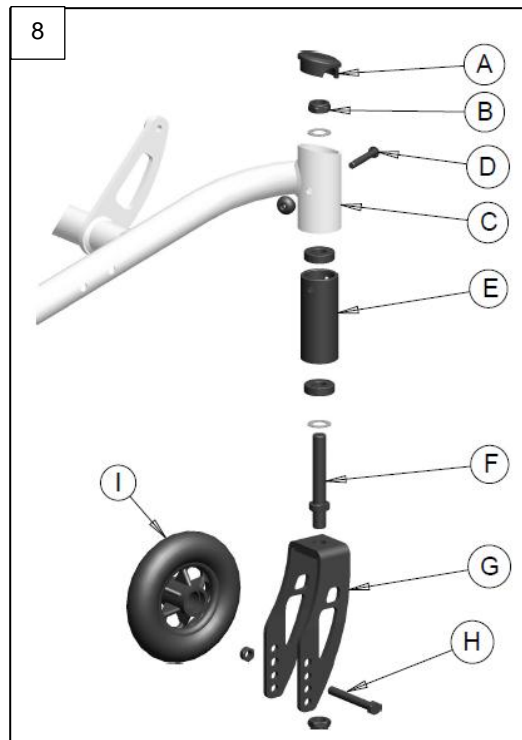

REAR WHEEL AXLE (QUICK RELEASE)

9

1. Quick Release Axle Check

Do not use this chair UNLESS you are sure both quick-release axles are locked. An unlocked axle may come off during use and cause a fall.

Note – Axle is not locked until the quick-release button (A) pops out fully.

2. To Install Wheel

- Depress quick-release button (A) fully. This will release tension on ball bearings at other end.
- Insert axle through hub of rear wheel (B).
- Keep pressure on button (A) as you slide axle (C) into axle sleeve (D).
- Release button to lock axle in sleeve. Adjust axle if it does not lock.
- Repeat steps on other side.

3. To Remove Wheel

- Depress quick-release button (A) fully.
- Remove wheel by sliding axle (C) out of axle sleeve (D).
- Repeat steps on other side.

4. Rear Wheel Axle Adjustment

Proper axle sleeves adjustment should be maintained for optimum performance of the wheelchair.

- To adjust the axle you will need a 5/8" wrench to turn the outside axle nut.
- You will also need a 10mm wrench on the opposite end of the axle, and prevent the axle from turning.
- Turn the outside axle nut clockwise to tighten.
- There should only be zero to ten thousandths of an inch (.010") of play.

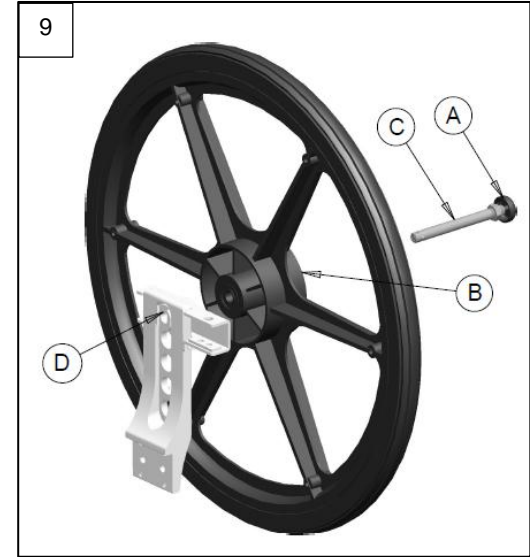

FRONT SEAT TO FLOOR SET-UP CHART

FRONT STF	REAR WHEEL	AXEL POSITION
13.00	12	5
13.00	16	3
13.00	20	1
14.00	16	4
14.00	20	2
14.00	22	1
15.00	16	5
15.00	20	3
15.00	22	2
15.00	24	1
16.00	20	4
16.00	22	3
16.00	24	2
17.00	20	5
17.00	22	4
17.00	24	3
18.00	22	5
18.00	24	4
19.00	24	5
20.00	24	5

1" RISER BLOCK

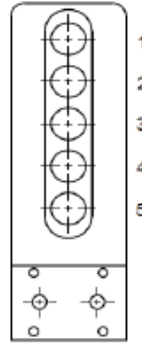

REAR AXEL PLATE

FRONT STF	CASTER	FORK	FORK POSITION	CASTER PLUG
13.00	5	SHORT	S1	SHORT
14.00	4	LONG	L2	SHORT
14.00	5	SHORT	S3	SHORT
14.00	5	LONG	L1	SHORT
14.00	5	SHORT	S1	MED
14.00	6	SHORT	S2	SHORT
15.00	4	LONG	L2	MED
15.00	5	LONG	L3	SHORT
15.00	5	SHORT	S3	MED
15.00	5	LONG	L1	MED
15.00	5	SHORT	S1	LONG
15.00	6	SHORT	S2	MED
15.00	6	LONG	L2	SHORT
16.00	4	LONG	L2	LONG
16.00	5	LONG	L3	MED
16.00	5	SHORT	S3	LONG
16.00	5	LONG	L1	LONG
16.00	6	SHORT	S2	LONG
16.00	6	LONG	L4	SHORT
16.00	6	LONG	L2	MED
16.00	8	LONG	L2	SHORT
17.00	5	LONG	L3	LONG
17.00	6	LONG	L4	MED
17.00	6	LONG	L2	LONG
17.00	8	LONG	L2	MED
18.00	6	LONG	L4	LONG
18.00	8	LONG	L2	LONG
19.00	8	LONG	L4	LONG
20.00	8	LONG	L4	LONG

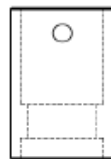
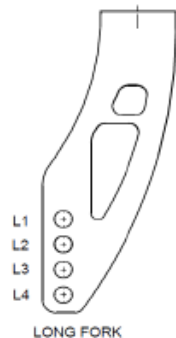
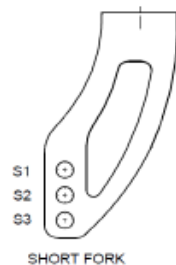

SHORT
PLUG

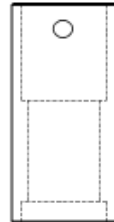

MEDIUM
PLUG

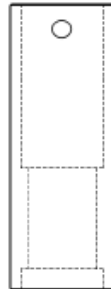

LONG
PLUG

1" RISER BLOCK

REAR WHEEL AXLE MOUNT

10

1. Axle Height Adjustment

- Loosen and remove lock-nut (E) from axle receiver (A).
- Set ant-tip bracket (C) at desired height using pre-set holes in rear axle mounting bracket (B).
- Replace and tighten lock-nut.
- Adjust set screw (D) to remove any play from bracket.

Important Note – The adjustment on each side of the chair should be exactly equal.

Important Note – The adjustment should be done by an authorized dealer only.

Note – Use a torque setting of 120 in-lbs when tightening the lock-nut.

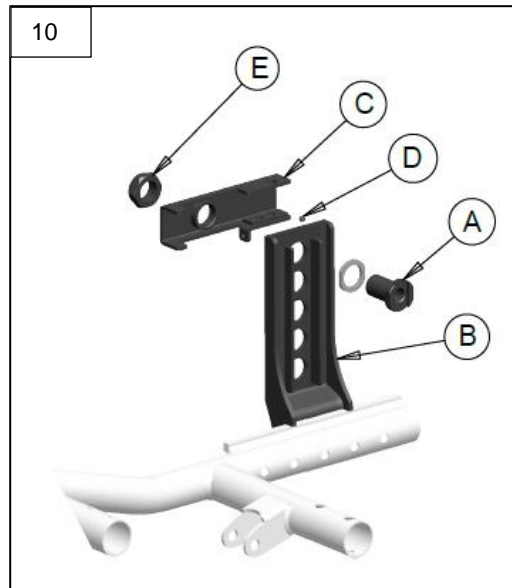

REAR WHEEL BRACKET MOUNT

11

1. Rear Wheel Horizontal Adjustment

- Loosen and remove lock-nuts (C) from bolts (A).
- Set rear wheel mounting bracket (B) at desired position using pre-set holes in lower side frame.
- Replace and tighten lock-nuts.
- Adjust lower set screws to position mounting bracket (B) at 90 degrees to the ground.

Important Note – The adjustment on each side of the chair should be exactly equal.

Important Note – The adjustment should be done by an authorized dealer only.

Note – Use a torque setting of 120 in-lbs when tightening the lock-nuts.

2. Weight Distribution

Weight distribution between the front and rear wheels is primarily adjusted by moving the rear axles forward or rearward on the frame.

Moving the axles REARWARD provides better forward and rearward tipping stability.

Moving the axles FORWARD shifts more of the rider's weight onto the REAR wheels, providing the following benefits: the front end of the wheelchair becomes lighter, thus reducing the turning effort, and with a shorter wheelbase the turning radius is reduced.

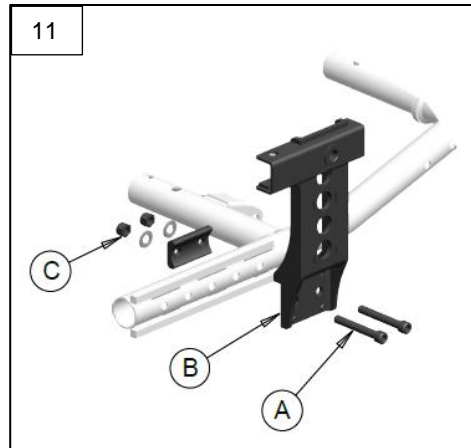

REAR ANTI-TIPS

12

1. Installing Rear Anti-tips onto Frame

- Loosen and remove lock-nut from bolt (B).
- Insert anti-tip mounting tube (C) into mounting bracket (A).
- Replace and tighten lock-nut.

2. Height Adjustment

The anti-tip tube wheels may have to be raised or lowered to achieve proper ground clearance of (1-1/2" to 2").

- Loosen and remove lock-nuts from bolts (D).
- Insert anti-tip onto anti-tip mounting tube (C) in desired location using pre-set holes.
- Replace and tighten lock-nuts.

3. Flipping Up Anti-tip

- Pull the sleeve (E) on the anti-tip out towards the wheel to release the pin engagement
- Rotate the anti-tip up until the pin engages in the upper slot.
- The same procedure is used to flip the anti-tip down.

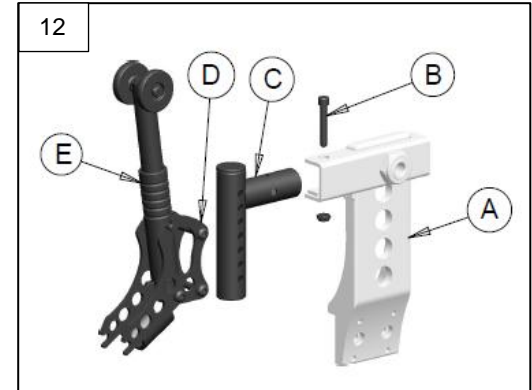

BACKREST AND STROLLER HANDLE

1. Backrest Angle Adjustment 13

- a. Loosen rear bolt (A).
- b. Loosen and remove angle adjustment bolt (B).
- c. Set backrest at desired angle using pre-set holes in plate. Each hole is at 7 degrees with the second from the end as the 90 degrees position.
- d. Replace and tighten the angle adjustment bolt (B).
- e. Tighten rear bolt (A).
- f. Repeat on other side of chair.

Important Note – The adjustment on each side of the chair should be exactly equal.

2. Flip-Down Back Rest Function 14

- a. To fold the back down, pull-up the back release pins (A) and push the backrest forward.
- b. To lock it back in position, push the release pins (A) sideways to allow them to reposition and lift the backrest firmly until it locks in its original position.

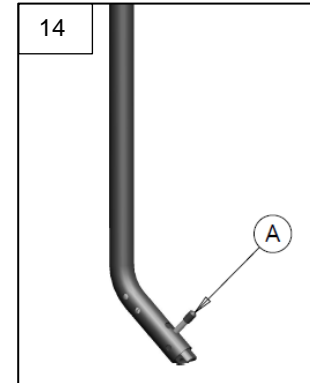
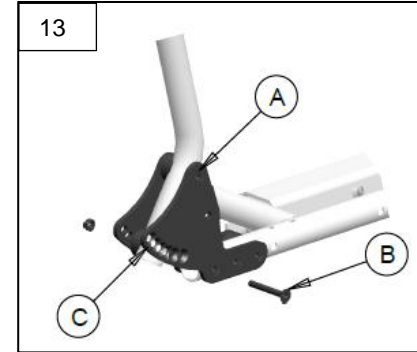

3. Adjustable Angle Stroller Bar

15

Depress both black push buttons (A) at the same time. This disengages the stroller handle and allows it to rotate freely. Releasing the push buttons positively locks the adjustable stroller handle in the desired position.

4. Recline Backrest Adjustment

16

- a. Depress trigger handle (A) which will disengage the recline gas cylinder.
- b. Tilt the backrest (B) to the desired angle and release the trigger handle.

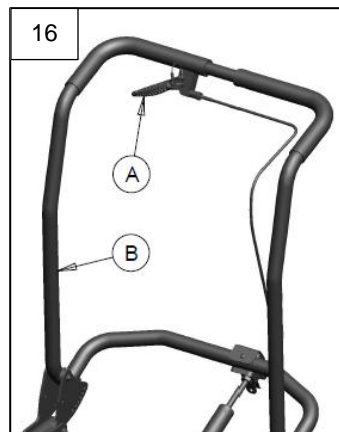
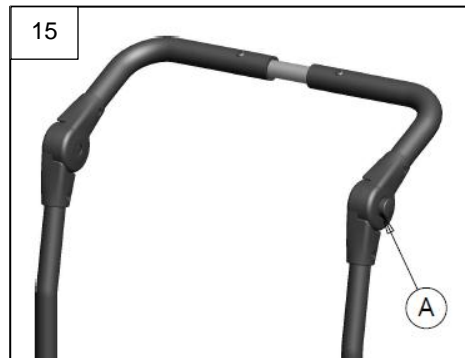

TILT MECHANISM

The tilt mechanism positively locks the chair in place from 0° to 45°.

1. Trigger Handle Tilt Function 17

- a. Depressing the trigger handle (A) will disengage both tilt gas cylinders.
- b. Tilt the chair (B) to the desired angle and release the trigger handle.
- c. A locking collar can be used on the gas cylinder rod to limit the tilt angle if required.

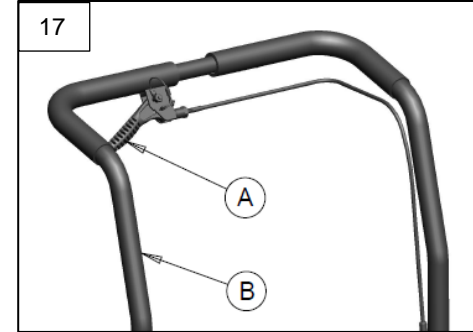

2. Attendant Foot Release Tilt Function 18

- a. Depressing attendant foot pedal (A) will disengage both tilt gas cylinders.
- b. Tilt the chair (B) to the desired angle and release the foot pedal.
- c. A locking collar can be used on the gas cylinder rod to limit the tilt angle if required.

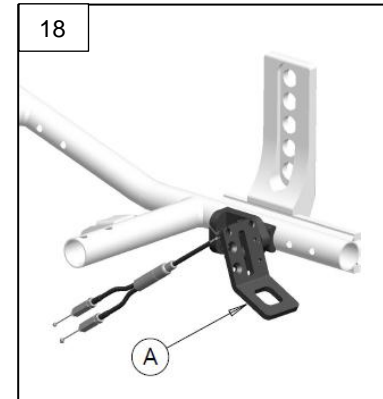

TRIGGER CABLE ADJUSTMENT 18A

- a. Loosen jam nut (B) on end of split cable (A).
- b. Rotate hex barrel spacer (C) to lengthen or shorten cable end ball.
- c. The slack from the cable end should be removed when the tilt release lever (D) is fully out. This will be when the trigger handle is released.
- d. The gas cylinder should be allowed to lock when the rod end pin on the gas cylinder is extended when the handle is released.

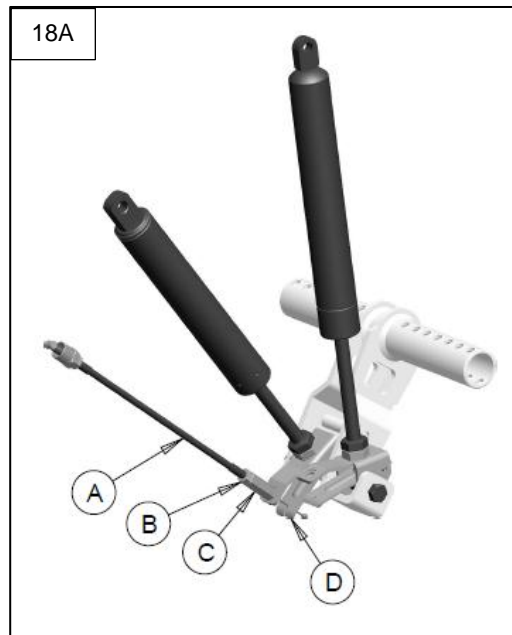

WHEEL LOCKS

1. Manual Wheel Lock Function and Adjustment

19

- a. To adjust, loosen the screws (A) but do not attempt to remove the screws.
- b. Slide the assembly (in the activated position) towards the rear wheel tire until the brake shoe (B) embeds into the tire preventing the wheel from turning.
- c. Tighten screws.
- d. To engage wheel lock, push handle (C) forward for the Push to Lock or pull the handle rearward for the Pull to lock version until the mechanism locks in place.

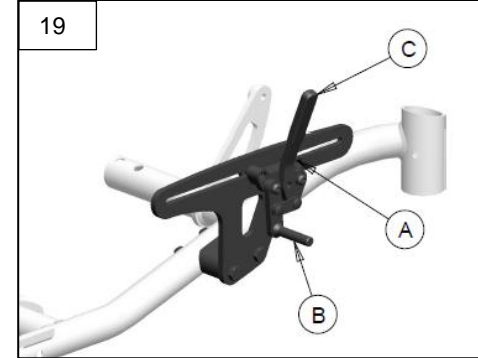

2. Berner Wheel Lock Function and Adjustment

20

- a. To adjust, loosen the screws (A) but do not attempt to remove the screws.
- b. Slide the assembly (in the activated position) towards the rear wheel tire until the brake shoe (B) embeds into the tire preventing the wheel from turning.
- c. Tighten screws.
- d. To engage wheel lock, push handle (C) forward for the Push to Lock or pull the handle rearward for the Pull to lock version until the mechanism locks in place.

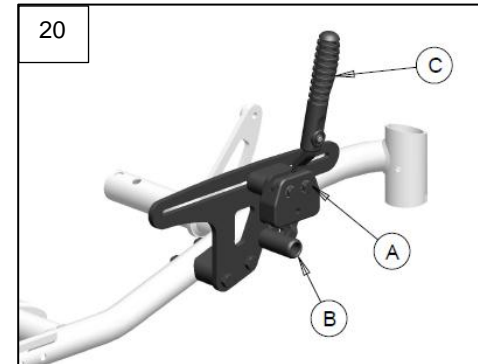

3. Berner Attendant Wheel Lock

21

22

- a. To adjust, loosen the screws (A) but do not attempt to remove the screws.
- b. Slide the assembly (in the activated position) towards the rear wheel tire until the brake shoe (B) embeds into the tire preventing the wheel from turning.
- c. Tighten screws.
- d. To activate wheel locks simultaneously, press down on the foot pedal (C) until the brake shoe engages the tire and locks in place.
- e. To deactivate the wheel locks, place toe of shoe under the foot pedal (C) and pull up until the brake shoe disengages from the tire. When deactivated the foot pedal will be in the up position.
- f. To adjust the cable, turn the adjustment screws (D) as necessary to ensure that the wheel locks can get to their fully extended position when the pedal is engaged. Position of the remote lock assembly may need to be fine tuned to optimize the force needed to engage the pedal, depending on tire type. If excessive force is needed to engage the pedal, cable life may be reduced. Once proper adjustment is attained, lock cable adjustment screw in position by tightening jam nuts against mounting block.

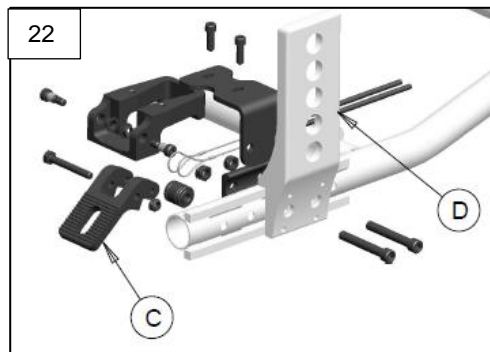
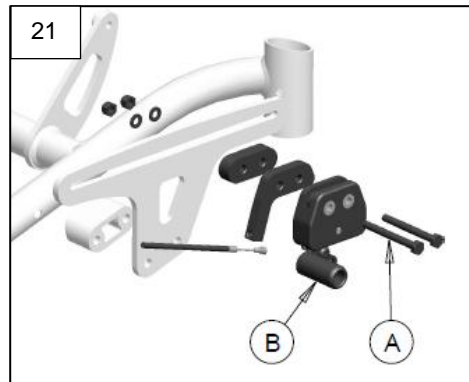

CHAIR WIDTH ADJUSTMENT

Note - For chair width adjustment all components such as the Lower Frame, Seat Frame, Front H-Link and Rear H-Link must be adjusted.

1. Lower Frame Width Adjustment

23

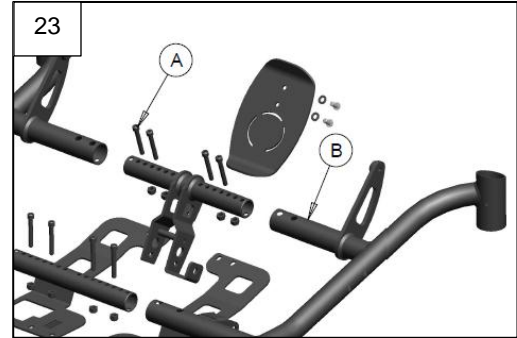

- a. To adjust, loosen and remove all screws (A) on one side of the lower frame (B) cross tubes.
- b. Slide the lower side frame to the desired width using the pre-set holes in both the side frame cross tube and center tube. (See Lower Crossbar Set-Up Chart)
- c. Replace and tighten screws.
- d. Repeat procedure for other side of lower frame. Check overall width to confirm.

2. Seat Frame Width Adjustment

24

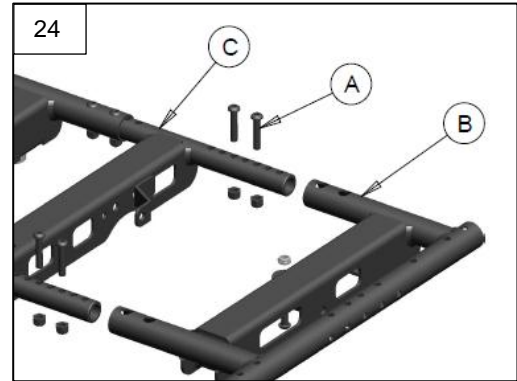

- a. To adjust, loosen and remove all screws (A) on one side of the seat frame (B) cross tubes.
 - a. Slide the seat frame to the desired width using the pre-set holes in both the seat frame cross tube (B) and center tube (C). (See Seat Frame Set-Up Chart)
 - b. Replace and tighten screws.
 - c. Repeat procedure for other side of seat frame. Check overall width to confirm.

3. H-Links Width Adjustment (Both Front and Rear)

25

- a. To adjust, loosen all screws (A) on both sides of the H-Links frame (B) cross tubes.
- b. Slide the H-Link frame to the desired width using the pre-set holes in both the H-Link frame cross tube and center tube (C).
- c. Tighten screws (A).

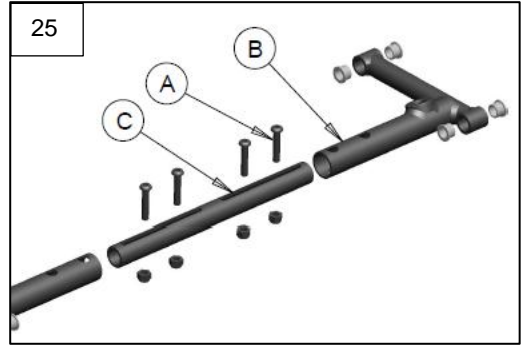

LOWER CROSSBAR SETUP - CHAIR WIDTH FROM 16" TO 20"

CHAIR WIDTH	16"	17"	18"	19"	20"
SETUP HOLE	1	2	3	4	5

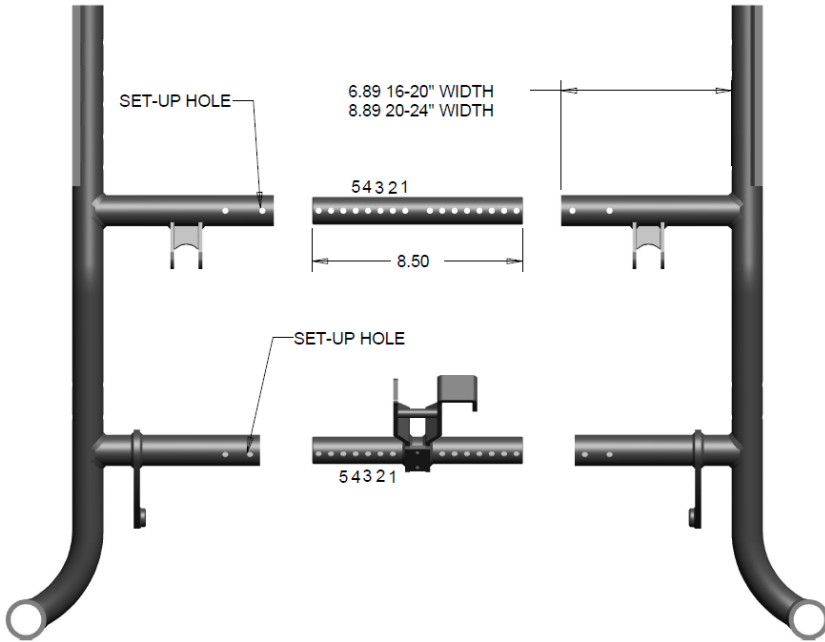

LOWER CROSSBAR SETUP - CHAIR WIDTH FROM 20" TO 24"

CHAIR WIDTH	20"	21"	22"	23"	24"
SETUP HOLE	1	2	3	4	5

SEATFRAME SETUP - CHAIR WIDTH FROM 16" TO 20"

CHAIR WIDTH	16"	17"	18"	19"	20"
SETUP HOLE	1	2	3	4	5

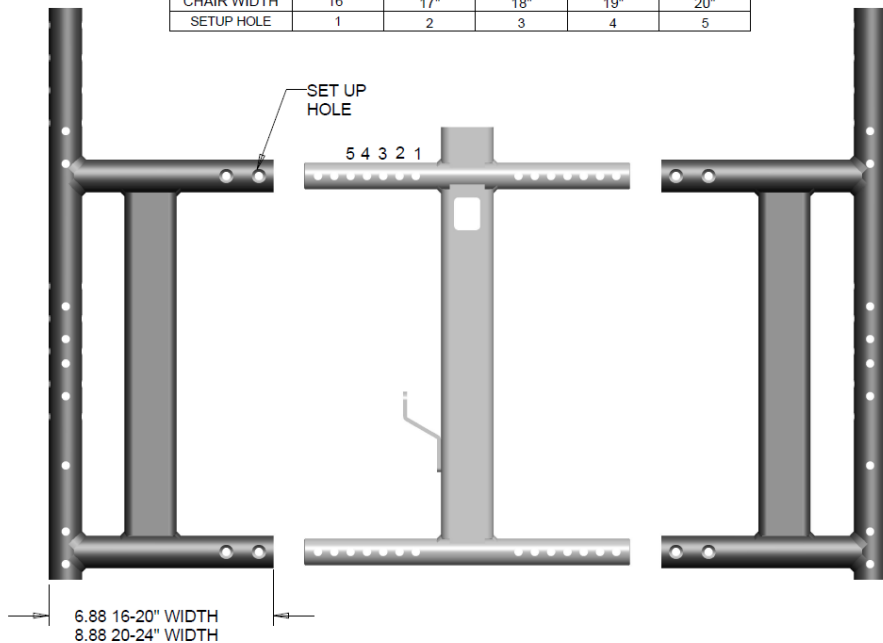

SEATFRAME SETUP - CHAIR WIDTH FROM 20" TO 24"

CHAIR WIDTH	20"	21"	22"	23"	24"
SETUP HOLE	1	2	3	4	5

SEAT DEPTH ADJUSTMENT

Note - The seat depth grows from the front of the chair. The footrest hanger is moved forward to grow the depth as required.

1. Seat Depth Adjustment

- a. To adjust, loosen and remove front screws holding the footrest hanger (B) to the seat frame side tube (A).
- b. Slide the footrest hanger (B) to the desired location using the pre-set holes to achieve the required seat depth.
- c. The hangers used come in two sizes. Short 15"-19" and Long 20"-23".

Important Note – The adjustment on each side of the chair should be exactly equal.

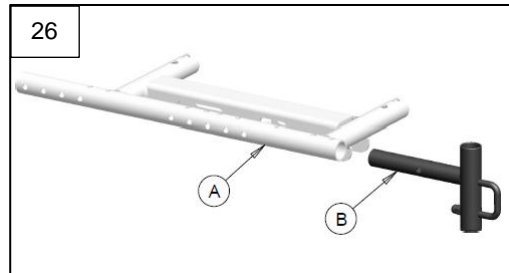

CUSHION INSTALLATION

- a. Place cushion on seat pan with hook material side down. The pommel of the cushion should be in front.
- b. Press cushion into place.

TIE-DOWNS

27

28

1. Front and Rear Tie-Downs

- a. If possible and feasible, the rider should transfer to the Original Equipment Manufacturer vehicle seat and use the vehicle restraint.
- b. If the wheelchair is used for transport, it must be used in a forward-facing seating position.
- c. The rider must not weigh more than 275 lbs.
- d. Front attachment point (A) and rear attachment point (B)

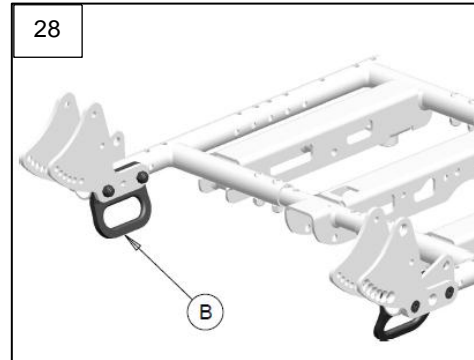
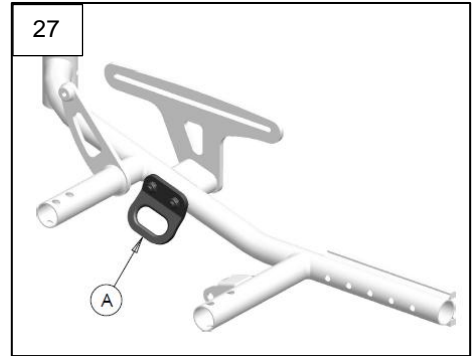

9 TROUBLE SHOOTING

You will need to adjust your chair from time to time in order to achieve the best performance (especially if you alter the original settings). This chart gives you a quick look at what might be causing your problem. You may need to look farther to find the best solution for a specific problem.

NOTE– To keep track of your progress, make only ONE change at a time.

Chair Veers Right/Left	Wheels Drift	Sluggish Turn or Performance	Caster Flutter	Squeaks and Rattles	Looseness in Chair	Solutions
		X	X	X	X	Check for loose nuts and bolts
X	X		X			Check angle adjustable caster assembly
X	X					Check that rear wheels are equally spaced away from seat frame.

10 MAINTENANCE

SAFETY INSPECTION CHECKLIST

Initial adjustments should be made to suit your body structure needs and preference. Please follow these maintenance procedures.

Item	Initially	Weekly	Monthly	Periodically
<u>GENERAL</u>				
Wheelchair rolls straight (no excessive drag or pull to one side)	X		X	
<u>FRAME AND CROSSING TUBES</u>				
Inspect for loose or missing hardware	X			X
Inspect for bent frame or cross-tubes	X			X
<u>WHEEL LOCKS</u>				
Do not interfere with tires when rolling	X		X	
Pivot points free of wear and looseness	X		X	
Wheel locks easy to engage	X			X
Wheel locks prevent chair from moving when engaged	X	X		
<u>SEAT AND BACK</u>				
Inspect for rips or sagging	X			X
Inspect for loose or broken hardware	X		X	
Inspect cane and hand grips for wear/looseness	X		X	
<u>TIRES</u>				
Inspect for flat spots, cracks and wear Caution: as with any vehicle, the wheels and tires should be checked periodically for cracks and wear and should be replaced.	X	X		X

<u>REAR WHEELS</u>				
If equipped, quick-release axles lock properly	X	X		
No excessive side movement or binding when lifted and spun	X			X
Inspect for cracked, bent or broken spokes	X	X		
<u>HANDRIMS</u>				
Inspect for signs of rough edges or peeling	X			X
<u>FRONT CASTERS/FORKS</u>				
Inspect caster fork assembly for proper tension by spinning caster; caster should come to a gradual stop	X	X		
Adjust bearing system if wheel wobbles or binds to a stop. Ensure wheel bearings are clean and free of moisture.	X		X	X
Check stem caster journal and lock nut for tightness	X		X	
Inspect casters for cracks and wear	X			X
Inspect for cracked, bent or broken spokes	X	X		
<u>CLEANING</u>				
Clean upholstery and armrests	X			X

GENERAL MAINTENANCE

1. Maintaining your chair in good working order will keep it functioning properly and help extend the working life of the chair.
2. Clean your chair often.
3. Make sure to replace worn or damaged parts as soon as possible to prevent future injury.
4. It is recommended to have any work done on the chair by an authorized dealer.
5. Follow the safety inspection checklist chart for optimum performance.
6. We recommend that once a year to have a complete inspection, service and safety check of your chair by an authorized dealer.



WARNING

Failing to follow these recommendations could lead to possible injury.

SERVICE AND REPAIR

1. Please contact the dealership or supplier from where the wheelchair was purchased for service and moderate repair.
2. In some circumstances, it may be necessary to return your wheelchair to Future Mobility for repairs.
3. Contact Future Mobility directly by telephone, fax, or e-mail to obtain information regarding repair at Future Mobility facilities.
4. You will be asked by the Customer Service Representative for the serial number that is affixed to the wheelchair.

5. If any of the following conditions are observed, the wheelchair must be serviced at Future Mobility:
 - a. Any part of the frame is cracked or broken
 - b. Any weld is cracked or broken
6. For safe and secure shipping, the wheelchair must be placed in a suitable carton, or fastened to a pallet, to ensure it does not sustain damage during shipping. Contact Future Mobility to receive specific instructions for packaging and shipping your wheelchair. Alternatively, Future Mobility may arrange for pick-up.

CLEANING YOUR CHAIR

1. Cleaning your Seat and Back

- a. Remove the outer and inner cover if required and hand wash with a small amount of detergent.
- b. Hang to dry the covers, do not machine dry or wring out.
- c. Use multipurpose disinfectant to spray seat, scrub with soft brush if needed.
- d. Test an inconspicuous area first for color-fastness.
- e. **DO NOT USE HOT AIR FOR DRYING.**
- f. **DO NOT IMMERSE** the cushion or back foam in water or cleaning solution.
- g. Some color leeching from the cover onto the foam is normal and cannot be washed out.

2. Paint Finish

- a. Clean the painted surfaces with mild soap at least once a month
- b. Protect the paint with a coat of non-abrasive auto wax every three months.

3. Axles and Pivot Joints

- a. Clean around axles and moving parts WEEKLY with a slightly damp (not wet) cloth.
- b. Wipe off or blow away any dust or dirt on axles or moving parts.



WARNING

Do not use abrasive powders or scouring pads on painted surfaces.

Do not ever submerge chair in water.

Do not use cleaning products without consulting the products' instructions and taking appropriate precautions for human exposure to chemicals.

11 WARRANTY

LIFETIME

Wheelchair Frame and Cross- Brace

1. Future Mobility Healthcare Inc. guarantees the frame and cross brace against defects in material and workmanship for life or for as long as the original purchaser owns the chair.
2. This warranty is void if:
 - a. The chair is shown to be abused.
 - b. The chair is not maintained as recommended in the owner's manual.
 - c. The chair is transferred to a different person from the original owner.

FOR TWO (2) YEARS

Wheelchair Back and Cushions (Excluding Upholstery)

1. Future Mobility Healthcare Inc. guarantees the back and cushion to be free of defects in material and workmanship for two years.

FOR ONE (1) YEAR

Wheelchair Components Excluding Limitations

1. Future Mobility Healthcare Inc. guarantees the wheelchair components to be free of defects in material and workmanship for one year.

FOR (90) DAYS

Cushion and Back Upholstery

1. Future Mobility Healthcare Inc. guarantees the wheelchair cushion and back upholstery to be free of defects in material and workmanship for 90 days.

LIMITATIONS

1. We do not warrant:
 - a. Tires, Tubes, Caster Wheels, Push-Handles and Grips.
 - b. Damage from negligence, accident, misuse, or from improper installation or repair.
 - c. Products modified without written consent from FMHI.
 - d. Damage from exceeding the wheelchair weight limit.
2. This warranty is VOID if the original chair serial number label is removed or altered.
3. This warranty is not transferable and only applies to the first consumer purchase of this wheelchair through an authorized Future Mobility Dealer.

WARRANTY PROCEDURES

1. If within this warranty period the product shall be proven to be defective, such product shall be repaired or replaced, at FMHI discretion.

2. FMHI's sole obligation and your exclusive remedy under this warranty shall be limited to the repair and/or replacement of the product or its parts.
3. This warranty does not include any labor or shipping charges incurred in replacement part installation or repair of any product.
4. For warranty service, please contact the dealer from whom you purchased your FMHI product. In the event you do not receive satisfactory warranty service, please write directly to FMHI.
5. DO NOT return products to FMHI without our prior consent. The defective unit or parts must be returned for warranty inspection within thirty (30) days of the return authorization date. (FMHI will issue a return authorization number). Please prepay all shipping charges; C.O.D. shipments will be refused.

The foregoing warranty is exclusive and in lieu of all other expressed warranties. It shall not extend beyond the duration of the expressed warranty provided herein and the remedy for violations of any implied warranty shall be limited to repair or replacement of the defective product pursuant to the terms contained herein. FMHI shall not be liable for any consequential or incidental damages whatsoever.

Cut below this line

Warranty Registration Form

To validate your Future Mobility HealthCare warranty, please complete the below form and return it the address at the end of this form. Visit online at www.futuremobility.ca for more Future Mobility Products.

Name: _____
Street Address: _____
City/Country/Postal Code: _____
Telephone: _____
Purchased Date: _____
Purchased From (Dealer Name and Address): _____
Product Purchased: _____
Serial Number: _____

Print and Mail it to:
Future Mobility Healthcare Products
3223 Orlando Drive
Mississauga, Ontario, L4V 1C5
Fax: 905-671-3377

CANADA

Future Mobility Healthcare Inc.

3223 Orlando Drive

Mississauga, ON, L4V 1C5

Ph: 905-671-1661 - 1 888 737 - 4011

Fax: 905-671-3377

e-mail: customerservice@futuremobility.ca

www.futuremobility.ca

USA

Future Mobility Products US LLC

1 Buffalo River Place

Buffalo, NY, 14210

Ph: 716-783-9130 - 1 855-938-8873

Fax: 716-783-9236

e-mail: customerservice@futuremobility.com

www.futuremobility.com

