



# 485HE

## High Efficiency Water Softener

Owners Manual



Proud member of Canadian Institute of Plumbing & Heating.



Proud member of Canadian Water Quality Association.

1. Read all instructions carefully before operation.
2. Avoid pinched o-rings during installation by applying (provided with install kit) NSF certified lubricant to all seals.
3. This system is not intended for treating water that is microbiologically unsafe or of unknown quality without adequate disinfection before or after the system.

**Canadian Head Office**  
655 Park St.  
Regina, SK S4N 5N1

**Eastern Sales & Distribution**  
20 Steckle Place, Unit 21  
Kitchener ON N2E 2C3

## Table of Contents

	<b>PAGE</b>
<b>Unpacking / Inspection</b>	<b>2</b>
<b>Safety Guide</b>	<b>2</b>
<b>Proper Installation</b>	<b>3</b>
<b>Specification</b>	<b>4</b>
<b>Before Starting Installation</b>	<b>4</b>
<b>Installation Instructions</b>	<b>6</b>
<b>System Start Up</b>	<b>8</b>
<b>Programming Instructions</b>	<b>9</b>
<b>About The System</b>	<b>10</b>
<b>Maintenance</b>	<b>12</b>
<b>Sanitizing Procedure</b>	<b>15</b>
<b>Main Repair Parts</b>	<b>16</b>
<b>Trouble Shooting</b>	<b>23</b>
<b>Warranty</b>	<b>24</b>

## Unpacking / Inspection

Be sure to check the entire softener for any shipping damage or parts loss. Also note damage to the shipping cartons. Contact the transportation company for all damage and loss claims. The manufacturer is not responsible for damages in transit.

Small parts, needed to install the softener, are in a parts bag. To avoid loss of the small parts, keep them in the parts bag until you are ready to use them.

## Safety Guide

*For your safety, the information in this manual must be followed to minimize the risk of electric shock, property damage or personal injury.*

- Check and comply with your provincial / state and local codes. You must follow these guidelines.
- Use care when handling the water softening system. Do not turn upside down, drop, drag or set on sharp protrusions.
- The water softening system works on 12 volt-60 Hz electrical power only. Be sure to use only the included transformer.
- Transformer must be plugged into an indoor 120 volt, grounded outlet only.
- Use clean water softening salts only, at least 99.5% pure. NUGGET, PELLET or coarse SOLAR salts are recommended. Do not use rock, block, granulated or ice cream making salts. They contain dirt and sediments, or mush and cake, and will create maintenance problems.
- Keep the salt lid in place on the softener unless servicing the unit or refilling with salt.
- **WARNING:** This system is not intended for treating water that is microbiologically unsafe or of unknown quality without adequate disinfection before or after the system.

## Proper Installation

*This water softening system must be properly installed and located in accordance with the Installation Instructions before it is used.*

- **Do not** install or store where it will not be exposed to temperatures below freezing or exposed to any type of weather. Water freezing in the system will break it. Do not attempt to treat water over 100°F.
- **Do not** install in direct sunlight. Excessive sun or heat may cause distortion or other damage to non-metallic parts.
- Properly ground to conform with all governing codes and ordinances.
- Use only *lead-free solder and flux* for all sweat-solder connections, as required by state and federal codes.
- Maximum allowable inlet water pressure is 125 psi. If daytime pressure is over 80 psi, night time pressure may exceed the maximum. Use a pressure reducing valve to reduce the flow if necessary.
- Softener resins may degrade in the presence of chlorine above 2 ppm. If you have chlorine in excess of this amount, you may experience reduced life of the resin. In these conditions, you may wish to consider purchasing a whole house carbon filter softener system with a chlorine reducing media.
- **WARNING:** Discard all unused parts and packaging material after installation. Small parts remaining after the installation could be a choke hazard.

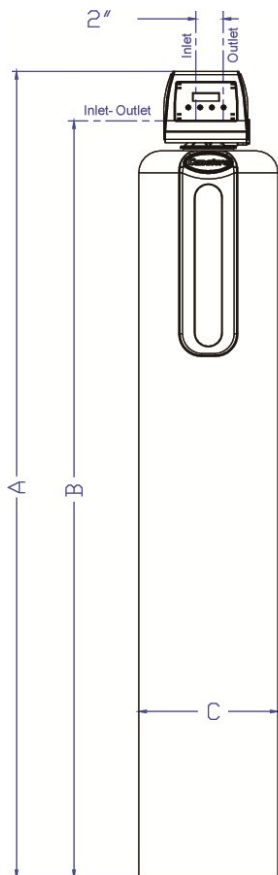

	A	B	C
0844	49.98"	46.54"	8"
0948	53.98"	50.54"	9"
1054	59.98"	56.54"	10"
1252	57.98"	54.54"	12"
1354	59.98"	56.54"	13"
1465	70.98"	67.54"	14"

	CS5 H 1017	CS5 H 1035
A	25.20"	43.31"
B	16.54"	16.54"

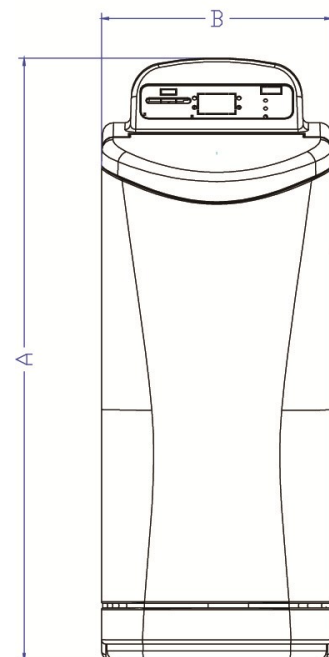
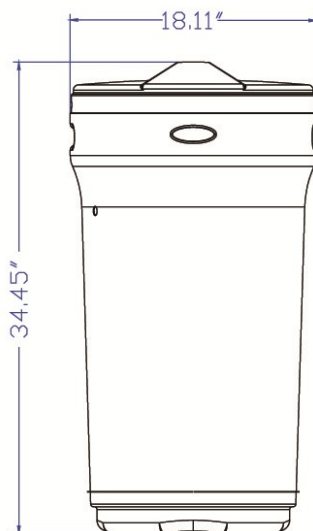

## Specifications

Specifications	485HE-75C	485HE-100C	485HE-75	485HE-100	485HE-150	485HE-200	485HE-300
	15010450	15010451	15010452	15010453	15010454	15010455	15010456
Optional Settings - High Efficiency							
Salt Used - Per Regeneration	2.3 lbs	3.0 lbs	2.3 lbs	3.0 lbs	4.5 lbs	6.0 lbs	9.0 lbs
Water Used - Regeneration	22.7 gal	28.3 gal	22.6 gal	31.6 gal	44.3 gal	60.9 gal	102.2 gal
Hardness Removal - Grains	11,250	15,000	11,250	15,000	22,500	30,000	45,000
<b>Factory Settings - Standard Capacity</b>							
Salt Used - Per Regeneration	4.5 lbs	6.0 lbs	4.5 lbs	6.0 lbs	9.0 lbs	12.0 lbs	18.0 lbs
Water Used - Regeneration	40.5 gal	48.6 gal	34.0 gal	43.4 gal	62.7 gal	87.1 gal	139.2 gal
Hardness Removal - Grains	18,750	25,000	18,750	25,000	37,500	50,000	75,000
Optional - High Capacity							
Salt Used - Per Regeneration	7.5 lbs	10.0 lbs	7.5 lbs	10.0 lbs	15.0 lbs	20.0 lbs	30.0 lbs
Water Used - Regeneration	56.1 gal	69.5 gal	49.6 gal	64.3 gal	90.3 gal	124.6 gal	196.2 gal
Hardness Removal - Grains	22,500	30,000	22,500	30,000	45,000	60,000	90,000
Resin Quantity - Cubic Feet	0.75 ft <sup>3</sup>	1.0 ft <sup>3</sup>	0.75 ft <sup>3</sup>	1.0 ft <sup>3</sup>	1.5 ft <sup>3</sup>	2.0 ft <sup>3</sup>	3.0 ft <sup>3</sup>
Tank Size	9x35	10x35	8x44	9x48	10x54	12x52	14x65
Tank Jacket / Media Loaded	Yes	Yes	Yes	Yes	Yes	No	No
Brine Tank / Cabinet Size (Inches)	16.5 x 19.3 x 14.3	16.5 x 19.3 x 14.3	18.1 x 34.5	18.1 x 34.5	18.1 x 34.5	20.3 x 37.4	23.0 x 40.5
Salt Storage Capacity	175 lbs	175 lbs	240 lbs	240 lbs	240 lbs	350 lbs	420 lbs
Flow Rate @ 15 psi Pressure Drop	11.6 gpm	12.0 gpm	10.4 gpm	11.0 gpm	11.2 gpm	12.2 gpm	12.6 gpm
Flow Rate @ 25 psi Pressure Drop	15.6 gpm	16.0 gpm	14.3 gpm	15.0 gpm	15.1 gpm	16.2 gpm	16.6 gpm
Back Wash Flow Rate	2.0 gpm	2.4 gpm	1.5 gpm	2.0 gpm	2.4 gpm	3.5 gpm	5.0 gpm
Shipping Weight	93 lbs	110 lbs	105 lbs	122 lbs	155 lbs	158 lbs	244 lbs
Regeneration Type	Counter Current / Up Flow						
Maximum Efficiency	5,060 grains /lb salt						
Plumbing Connections	3/4" (Optional 1")						
Resin Type	Canature 8% High Capacity Ion Exchange Resin						
Electrical Requirements	Input 120V 60 Hz - Output 12V 650mA						
Water Temperature	Min 39 - Max. 100 degrees Fahrenheit						
Water Pressure	Min. 20 - Max. 125 psi						

- Continuous operation at flow rates greater than the service flow rate may affect capacity and efficiency performance.
- The manufacturer reserves the right to make product improvements which may deviate from the specifications and descriptions stated herein, without obligation to change previously manufactured products or to note the change.

## Before Starting Installation

### Tools, Pipe, and Fittings, Other Materials

- Pliers
- Screwdriver
- Teflon tape
- Razor knife
- Two adjustable wrenches
- Additional tools may be required if modification to home plumbing is required.
- Plastic inlet and outlet fittings are included with the softener. To maintain full valve flow, 3/4" or 1" pipes to and from the softener fittings are recommended. You should maintain the same, or larger, pipe size as the water supply pipe, up to the softener inlet and outlet.
- Use copper, brass, or PEX pipe and fittings.
- Some codes may also allow PVC plastic pipe.
- ALWAYS install the included bypass valve, or 3 shut-off valves. Bypass valves let you turn off water to the softener for repairs if needed, but still have water in the house pipes.
- 5/8" OD drain line is needed for the valve drain. A 10' length of hose is included with some models.
- A length of 5/8" OD drain line tubing is needed for the brine tank over flow fitting (optional).
- Nugget or pellet water softener salt is needed to fill the cabinet or brine tank.

## Where To Install The Softener

- Place the softener as close as possible to the pressure tank (well system) or water meter (city water).
- Place the softener as close as possible to a floor drain, or other acceptable drain point (laundry tub, sump, standpipe, etc.).
- Connect the softener to the main water supply pipe BEFORE the water heater. **DO NOT RUN HOT WATER THROUGH THE SOFTENER.** Temperature of water passing through the softener must be less than 100 deg. F.
- Keep outside faucets on hard water to save soft water and salt.
- Do not install the softener in a place where it could freeze. **Damage caused by freezing is not covered by the warranty.**
- Put the softener in a place water damage is least likely to occur if a leak develops. The manufacturer will not repair or pay for water damage.
- A 120 volt electric outlet, to plug the included transformer into, is needed within 6 feet of the softener. The transformer has an attached 6 foot power cable. **Be sure the electric outlet and transformer are in an inside location, to protect from wet weather.**
- If installing in an outside location, you must take the steps necessary to assure the softener, installation plumbing, wiring, etc., are as well protected from the elements, contamination, vandalism, etc., as when installed indoors.
- **Keep the softener out of direct sunlight.** The sun's heat may soften and distort plastic parts.

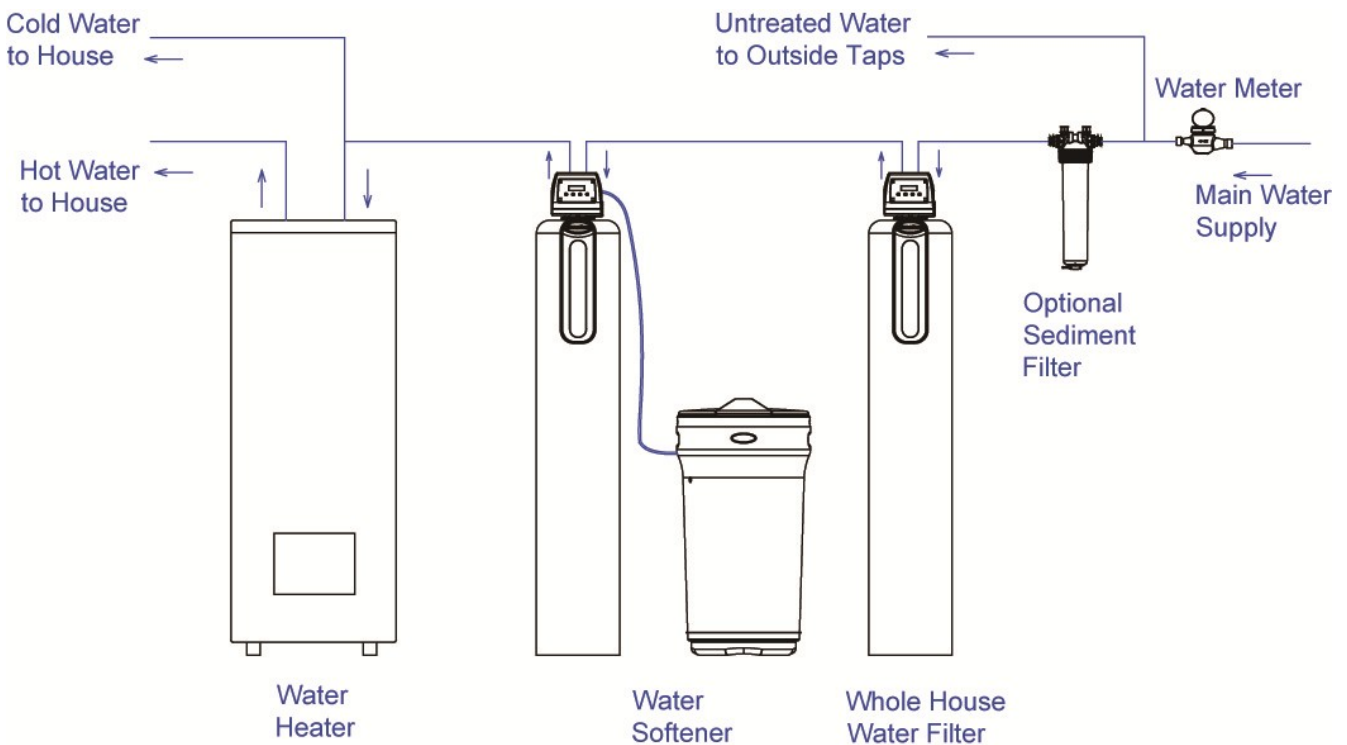

## Installation Instructions

1. If your hot water tank is electric, turn off the power to it to avoid damage to the element in the tank.
2. If you have a private well, turn the power off to the pump and then shut off the main water shut off valve. If you have municipal water, simply shut off the main valve. Go to the faucet, (preferably on the lowest floor of the house) turn on the cold water until all pressure is relieved and the flow of water stops.
3. Locate the softener tank and brine tank close to a drain where the system will be installed. The surface should be clean and level.
4. Connect the inlet and outlet of the softener using appropriate fittings. Perform all plumbing according to local plumbing codes.
  - Use a ½" minimum pipe or tubing size for the drain line
  - **ON COPPER PLUMBING SYSTEMS BE SURE TO INSTALL A GROUNDING WIRE BETWEEN THE INLET AND OUTLET PIPING TO MAINTAIN GROUNDING.**

Any solder joints near the valve must be done before connecting any piping to the valve. Always leave at least 6" (152 mm) between the valve and joints when soldering pipes that are connected to the valve. Failure to do this could cause damage to the valve.

5. Connect the drain hose (10 ft included) to the valve and secure it with a hose clamp (also included). Run the drain hose to the nearest laundry tub or drain pipe. This can be ran up overhead or down along the floor. If running the drain line more than 20 ft overhead, it is recommended to increase the hose size to ¾". NEVER MAKE A DIRECT CONNECTION INTO A WASTE DRAIN. A PHYSICAL AIR GAP OF AT LEAST 1.5" SHOULD BE USED TO AVOID BACTERIA AND WASTEWATER TRAVELLING BACK THROUGH THE DRAIN LINE INTO THE SOFTENER.
6. Using the Allen Key (included), place the unit in the bypass position. Slowly turn on the main water supply. At the nearest cold treated water tap nearby remove the faucet screen, open the faucet and let water run a few minutes or until the system is free of any air or foreign material resulting from the plumbing work.
7. Make sure there are no leaks in the plumbing system before proceeding. Close the water tap when water runs clean.
8. Open the brine tank / cabinet salt lid and add water until there is approximately 3" (75 mm) of water in the tank. Do not add salt to the brine tank at this time.
9. Proceed to start up instructions.

**Note: The unit is not ready for service until you complete the start-up instructions.**

# Installation Twin Tank

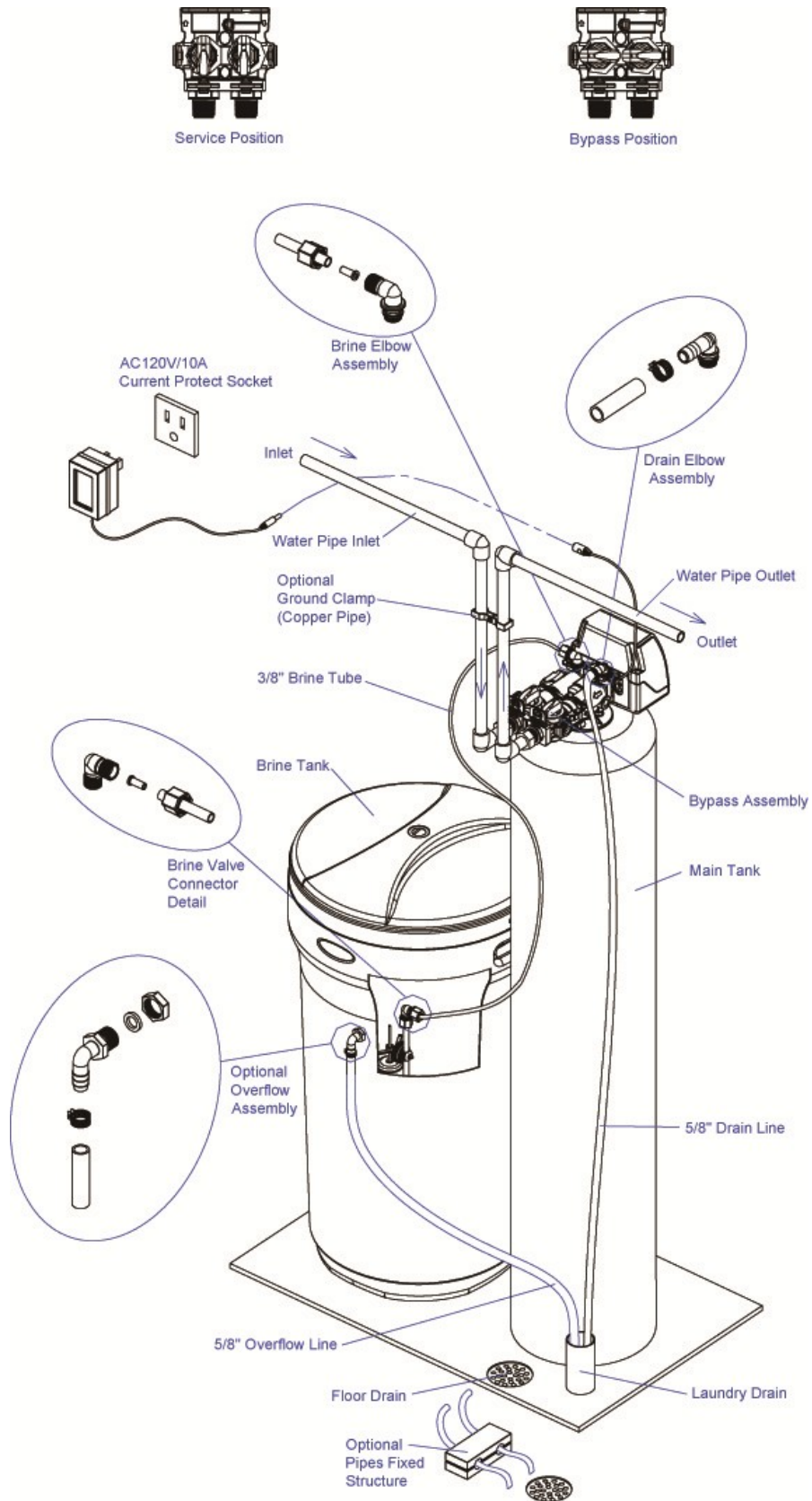



# Installation Cabinet

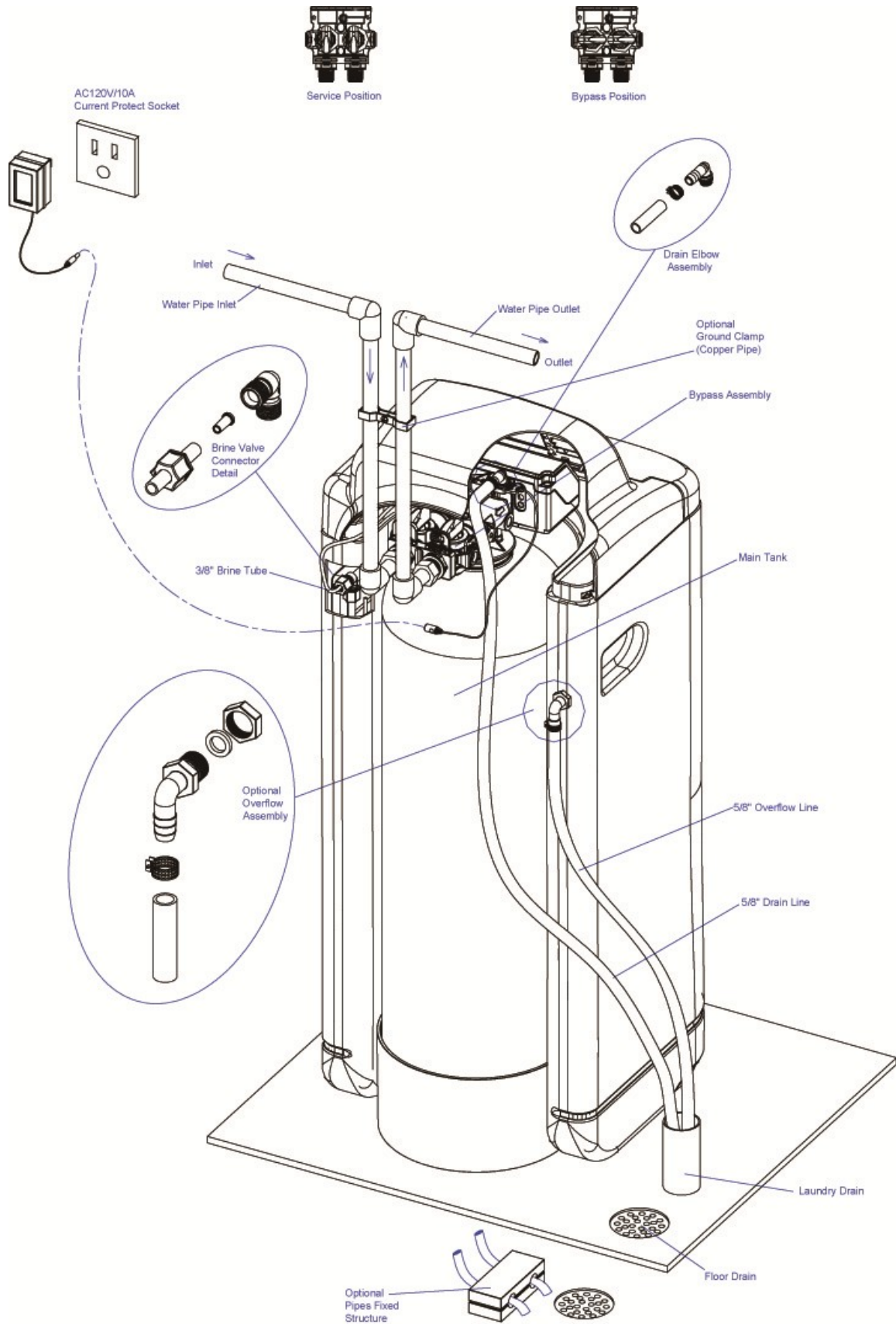



## System Start-Up

### Key Pad Configuration

SETTINGS	This function is to enter the basic set up information required at the time of installation.
MANUAL REGEN	This function is to initiate an immediate or delayed manual regeneration.
DOWN / UP	Increase or decrease the value of the settings while in the programming mode.

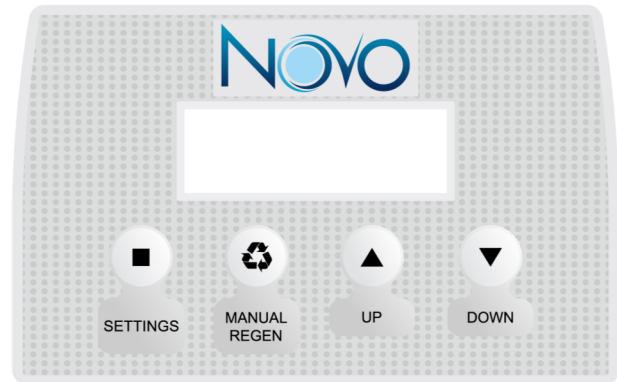

### Manual Regeneration (Step / Cycle Valve)

#### **DELAYED REGENERATION**

Press and release the MANUAL REGEN. Button to set a delayed regeneration that will occur at the regeneration time. The main display page will show DELAYED REGEN ON. To cancel press and release the MANUAL REGEN. Button. The main display page will show DELAYED REGEN OFF.

#### **IMMEDIATE REGENERATION**

To start an immediate regeneration (or step valve through each position), press and hold the MANUAL REGEN. Button for 3 seconds (until beeps). The valve will start an immediate regeneration. Press any key to skip to the next cycle.

### Start-up Instructions

1. Plug the power transformer into an approved power source. Connect the power cord to the valve.
2. When power is supplied to the control, the screen will display "INITIALIZING WAIT PLEASE" while it finds the service position.
3. Manually step the valve past the BRINE position to the BACKWASH position. If screen is locked, press SETTINGS for 3 seconds to unlock. Press and hold the MANUL REGEN. Key for 3 seconds. Press any key to skip the BRINE cycle.
4. Once in the BACKWASH cycle, open the inlet on the bypass valve slowly and allow water to enter the unit. Allow all air to escape from the unit before turning the water on fully then allow water to run to drain for 3-4 minutes or until all media fines are washed out of the softener indicated by clear water in the drain hose.
5. Press any button to advance to the RINSE position. Check the drain line flow. Allow the water to run for 3-4 minutes or until the water is clear.
6. Press any button to advance to the REFILL position. Check that the valve is filling water into the brine tank. Allow the valve to refill for the full amount of time as displayed on the screen to insure a proper brine solution for the next regeneration.
7. The valve will automatically advance to the SERVICE position. Open the outlet valve on the bypass, then open the nearest treated water faucet and allow the water to run until clear, close the tap and replace the faucet screen.
8. Add salt into the cabinet / brine tank.
9. Program unit.

## Programming Instructions

### Settings

Press SETTINGS key (3 SECONDS / BEEP)

VALVE MODE  
SOFTENER UF

TIME OF DAY  
12:01 PM

YEAR  
2012

MONTH  
AUGUST

DAY  
21

SET HARDNESS  
20 GRAINS

SET PEOPLE  
4

SALT SETTING  
HIGH EFFICIENCY  
STANDARD  
IRON & MN

WATER TYPE  
MUNICIPAL  
WELL / OTHER

REGEN TIME  
2:00 AM

PROGRAMMING  
COMPLETE

**TIME OF DAY, YEAR, MONTH, DAY,** but still operate the system with good efficiency.

Time of day is for normal operation of system and the scheduling of the regeneration time. The date is used in a diagnostic function to track the last time the system regenerated.

### **SET HARDNESS**

This value is the maximum compensated water hardness in grains per gallon of the raw water supply. It is used to calculate the system capacity. If Ferrous Iron is present add 4 gpg for every 1 ppm of Ferrous Iron.

### **SET PEOPLE**

This value is the number of people living in the home. It is used to calculate the amount of water needed for daily use and the reserve capacity of the system.

### **SALT SETTING**

Choose HIGH EFFICIENCY to minimize salt usage. Your system will regenerate a little more often but your salt usage can be reduced by 20% compared to the STANDARD setting.

Choose STANDARD when you need to maximize your capacity

Choose IRON & MN if you have problem water containing these minerals. The high salt setting will be needed since these minerals are more difficult to clean out of the resin bed. Note: A resin cleaner will also need to be periodically added to the brine tank to insure proper operation.

### **WATER TYPE**

This setting will determine if the BACKWASH OVERRIDE function will be on or off. Select MUNICIPAL if the water source is clean (<1NTU turbidity) and the system will skip the back wash cycle based on the setting in BACKWASH OVERRIDE.

Select WELL / OTHER if any Iron or Manganese is present or if the water source is not clean (< 1NUT turbidity). The system will back wash every time.

### **REGEN TIME**

This setting determines the time of day to perform a scheduled regeneration.

## About The System

### Control Operation During A Power Failure

In the event of a power failure, the valve will keep track of the time and day for 48 hours. The programmed settings are stored in a non-volatile memory and will not be lost during a power failure. If power fails while the unit is in regeneration, the valve will finish regeneration from the point it is at once power is restored. If the valve misses a scheduled regeneration due to a power failure, it will queue a regeneration at the next regeneration time once power is restored.

### Safety Float

The brine tank is equipped with a safety float which prevents your brine tank from overflowing as a result of a malfunction such as a power failure.

### Main Display

The main display page will pause on the Date and Time page for 5 seconds. Then it will continually scroll through all of the system diagnostic display pages. Depending on the Valve Type some pages will not be displayed. To manually scroll through the diagnostics, press the down or up key. To reset the TOTAL REGENS, TOTAL GALLONS OVER RUN TOTAL, or PEAK flow rates, press and hold the MENU until the value changes to zero.

PARAMETER	DESCRIPTION
JULY/17/2012 8:30 PM	Month, Day, Year, Time
TOTAL 1,500 GAL REMAIN 1,200 GAL	The total amount is the system capacity when fully regenerated. The remaining is the capacity left in the system.
PEOPLE 2 RESERVE 150 GAL	Number of people in the household and the calculated reserve capacity. When remaining reaches reserve capacity a regeneration will be scheduled.
EST. DAYS TO NEXT REGEN 06 DAYS	The estimated number of days until the next regeneration will occur.
LAST REGEN 9/24/12	The date of the last regeneration.
TOTAL REGENS 10	The total number of regenerations.
TOTAL GALLONS 001590 GAL	The total amount of gallons treated by the system.
OVER RUN TOTAL 0500 GAL	The total amount of water that has exceeded the system capacity over the last 4 regenerations. When remaining goes to zero, the gallons used will be added to over run total.
CURRENT 1.5 GPM PEAK 6.5 GPM	The current flow rate and the peak flow rate since the last regeneration.
DELAYED REGEN OFF	Advises whether a delayed regeneration has been scheduled manually or automatically.
REGEN TIME 2:00 AM	The current setting for regeneration time.
REFILL TIME 3:00 MIN	The current calculated refill time.
VALVE MODE SOFTENER UF	The current setting of the valve mode.

### New Sounds

You may notice new sounds as your water softener operates. The regeneration cycle lasts up to 180 minutes. During this time, you may hear water running intermittently to the drain.

## Precision Brining Regeneration Process

When the system capacity is near exhausted, a regeneration is necessary to restore the system to full capacity. The table below explains the regeneration steps.

Step	Name	Description
#1	Brine Making	A precise calculated amount of fresh water is added to the brine tank to make enough brine to regenerate only the exhausted portion of the ion exchange resin. Note: 70% of the required fresh water is added in Step #5 in the previous regeneration. The default brine making time is 30 minutes.
#2	Brine	The brine solution is introduced slowly to the bottom of the tank flowing up through the ion exchange resin pushing the hardness out to drain and restoring system capacity.
#3	Back Wash	Fresh water is introduced to the bottom of the tank flowing upwards expanding the ion exchange resin to rinse out any dirt or small particles to the drain and to un-compact the bed to restore full service flow rates.
#4	Rinse	Fresh water is introduced from the top of the tank down flowing down through the ion exchange resin rinsing any excess brine solution out to the drain.
#5	Refill	A fixed amount of soft water is added to the salt tank to prepare and insure fully saturated brine for the next regeneration. Note: Step #1 will "top off" the amount of water needed based on the percentage of exhausted resin to be regenerated.

## Automatic Hard Water Bypass During Regeneration

The regeneration cycle can last 30 to 180 minutes, after which soft water service will be restored. During regeneration, hard water is automatically bypassed for use in the household. Hot water should be used as little as possible during this time to prevent hard water from filling the water heater. This is why automatic regeneration is set for sometime during the night and manual regenerations should be performed when little or no water will be used in the household.

Normal regeneration time is 2:00 AM.

## System Configuration

485HE UPFLOW System Configuration			
Tank Size (Diameter)	Injector Set	Brine Line Flow Control (BLFC)	Drain Line Flow Control (DLFC)
8"	#0000 Black	0.20 GPM	#1 (1.5 GPM)
9"			#2 (2.0 GPM)
10"			#3 (2.4 GPM)
12"	#00 Purple		#5 (3.5 GPM)
13"	#0 Red		#6 (4.0 GPM)
14"	#1 WHITE		#A (5.0 GPM)

## Manual Bypass

In the case of emergency, such as an overflowing brine tank, you can isolate your water softener from the water supply using the bypass valve located at the back of the control. In normal operation the bypass is open with the on/off knobs in line with the inlet and outlet pipes.

To isolate the softener, simply rotate the knobs clockwise (as indicated by the word BYPASS and arrow) until they lock. You can use your water related fixtures and appliances as the water supply is bypassing the softener. However, the water you use will be hard. To resume soft water service, open bypass valve by rotating the knobs counterclockwise.

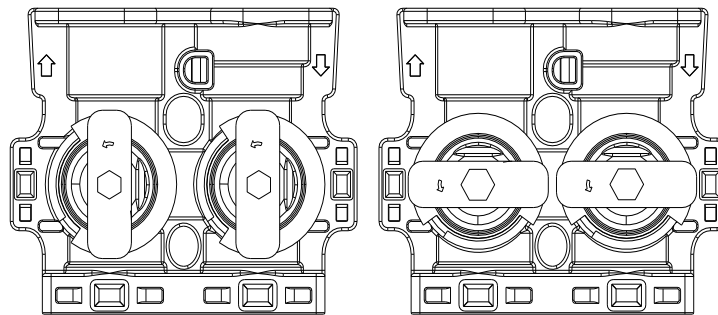

SERVICE POSITION

BYPASS POSITION

## Maintenance

### Adding Salt

Use only crystal water softener salt. Check the salt level monthly. It is important to maintain the salt level above the water level. To add salt, simply lift the salt lid and add the salt directly into the brine tank. Be sure the brine well cover is on and fill only to the height of the brine well.

### Bridging

Humidity or wrong type of salt may create a cavity between the water and the salt. This action, known as "bridging", prevents the brine solution from being made, leading to your water supply being hard.

If you suspect salt bridging, carefully pound on the outside of the brine tank or pour some warm water over the salt to break up the bridge. This should always be followed up by allowing the unit to use up any remaining salt and then thoroughly cleaning out the brine tank. Allow two hours to produce a brine solution, then manually regenerate the softener.

## Cleaning or Replacing Injectors

Sediment, salt and silt will restrict or clog the injector. A clean water supply and pure salt will prevent this from happening.

The injector assembly is located on the right side of the control valve. This assembly is easy to clean.

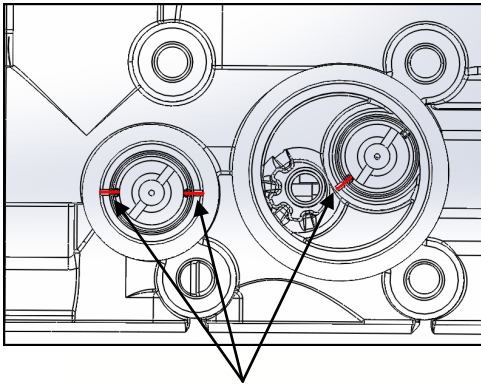

TIP: There are marks on the injector holder that must be lined up to the marks on the valve to fully insert the holder into the hole in the valve body

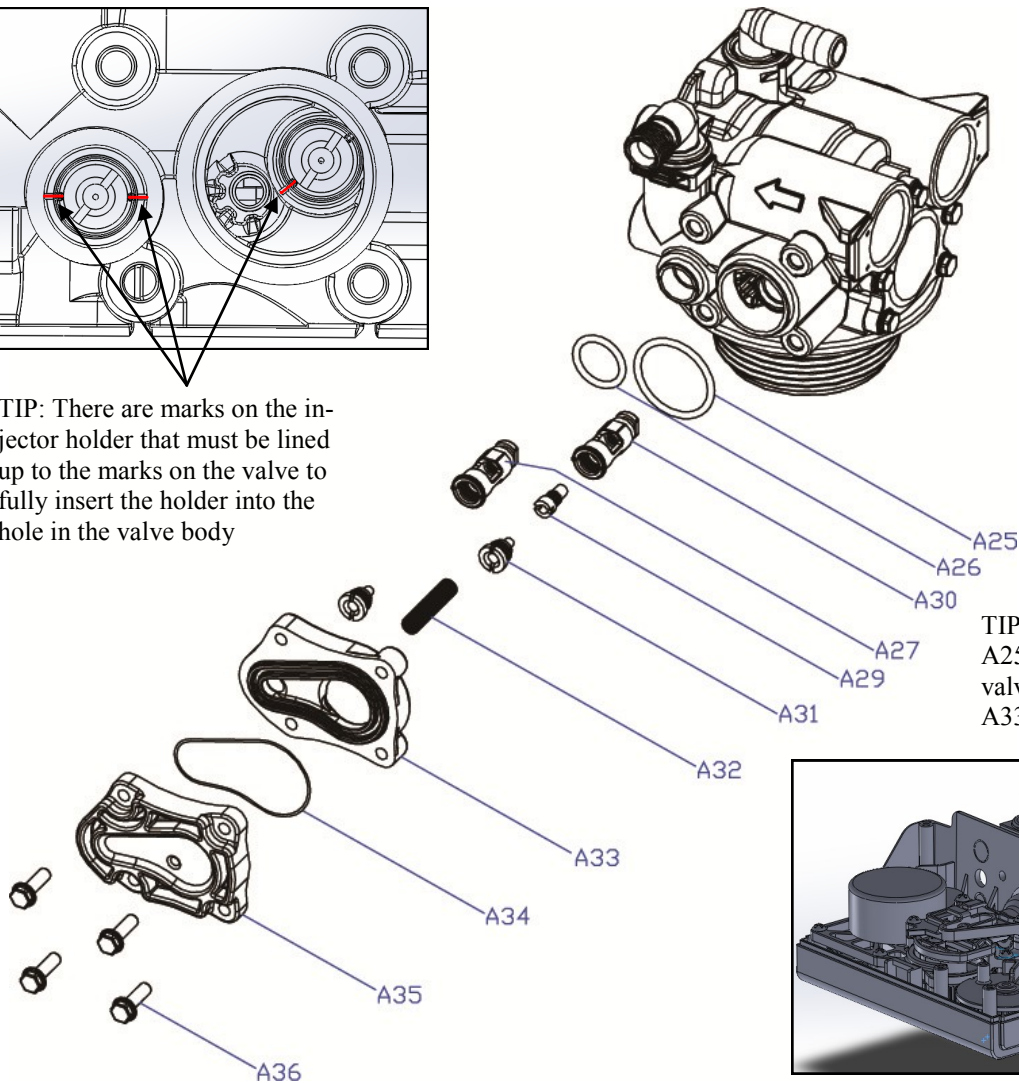

TIP: Place the o-rings A25 and A26 onto the valve before installing A33.

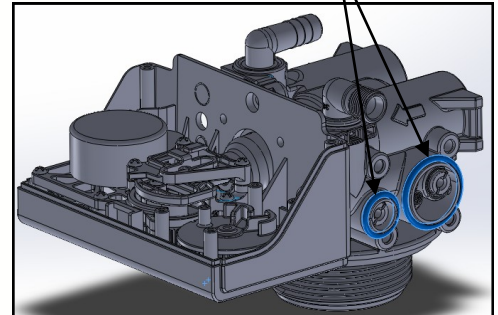

1. Shut off the water supply to your softener and reduce the pressure by opening a cold soft water faucet.
2. Using a screwdriver, remove the four screws holding the injector cover to the control valve body.
3. Carefully remove the assembly and disassemble as shown in above figure.
4. The injector orifice is removed from the valve body by carefully turning it out with a large screwdriver. Remove the injector throat the same way.
5. Carefully flush all parts including the screen. Use a mild acid such as vinegar or Pro-Rust Out to clean the small holes in the orifice and throat.
6. Reassemble using the reverse procedure.



## Replacing Brine Line Flow Control (BLFC)

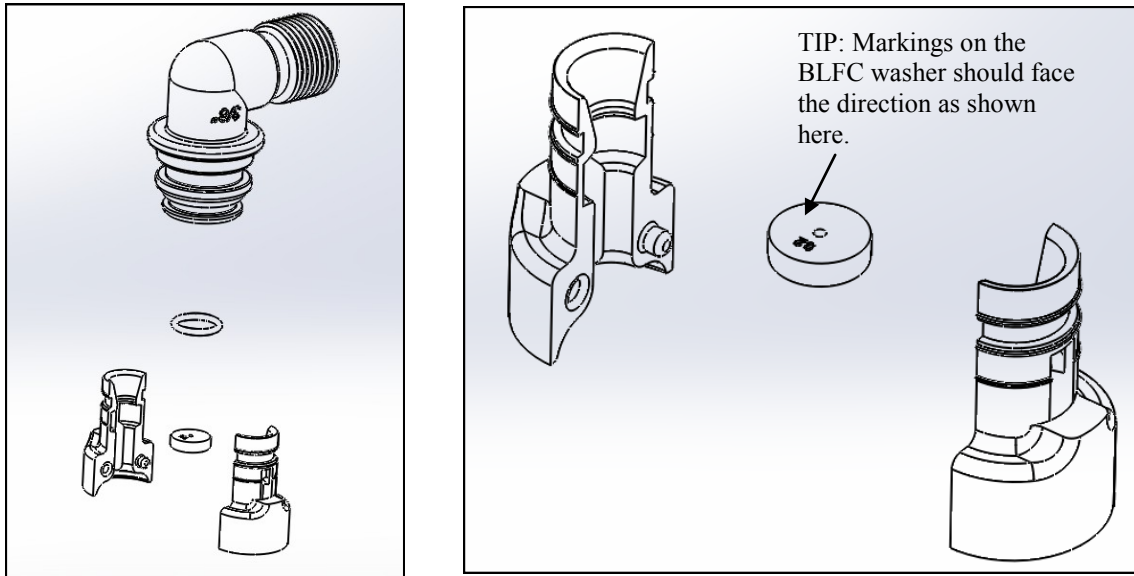

1. Remove the red clip that secures the brine elbow.
2. Remove the BLFC holder from the elbow fitting.
3. Split the BLFC holder apart and remove the flow washer.
4. Reassemble using the reverse procedure.

## Replacing Drain Line Flow Control (DLFC)

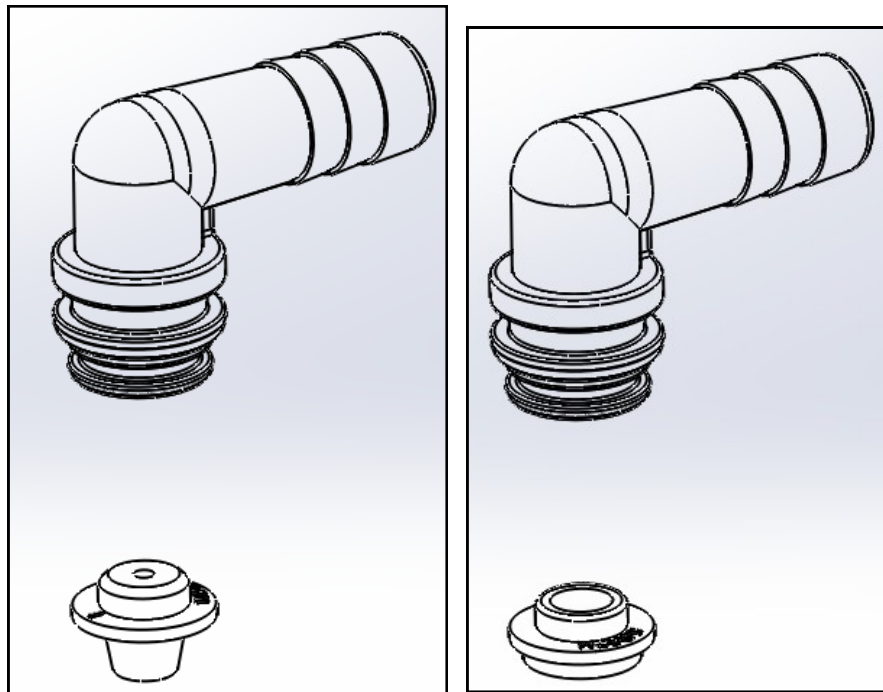

1. Remove the red clip that secures the drain line elbow.
2. Remove the BLFC washer from the elbow fitting.
3. Reassemble using the reverse procedure.

## Care of Your System

To retain the attractive appearance of your new water softener, clean occasionally with mild soap solution. Do not use abrasive cleaners, ammonia or solvents. Never subject your softener to freezing or to temperatures above 100°F.

### Resin Cleaner

An approved resin cleaner must be used on a regular basis if your water supply contains iron. The amount of resin cleaner and frequency of use is determined by the quantity of iron in your water (consult your local representative or follow the directions on the resin cleaner package).



Item #	Description
80030006	Res Care - 1 gal. Bottle
80030005	Res Care - 1 qt. Bottle

Item #	Description
80030002	Rust Out - 1.5 lb. Bottle
80030003	Rust Out - 5 lb. Bottle
80030004	Rust Out - 50 lb. Pail

Item #	Description
55030001	Res Up Feeder - 0.5 oz/day Feeder
55030002	Res Up Feeder - 1.0 oz/day Feeder

## Sanitizing Procedure

Care is taken at the factory to keep your water softener clean and sanitary. Materials used to make the softener will not infect or contaminate your water supply, and will not cause bacteria to form or grow. However, during shipping, storage, installing and operating, bacteria could get into the softener. For this reason, sanitizing as follows is suggested when installing.

### Sani-System Liquid Sanitizer Concentrate



Item# 80030021—Softener Sanitizer 0.25 fl.oz (24 Pack)

1. Be sure to complete all installation steps, including programming.
2. For effective and complete sanitization, Sani-System Liquid Sanitizer Concentrate is recommended. Pour one 0.25 fl. Oz. package into the brine well located in the cabinet or brine tank. (Alternative use 3/4 oz of common 5.25% household bleach)
3. Start an immediate regeneration. (See page 11)
4. The Softener Sanitizer Solution is drawn into and through the water softener to sanitize it. This sanitizing regeneration is over in about two hours. Then, **soft water** is available for your use.

NOTE: Sanitizing is recommended by the Water Quality Association for disinfecting. On some water supplies, they suggest periodic sanitizing.

# Main Repair Parts

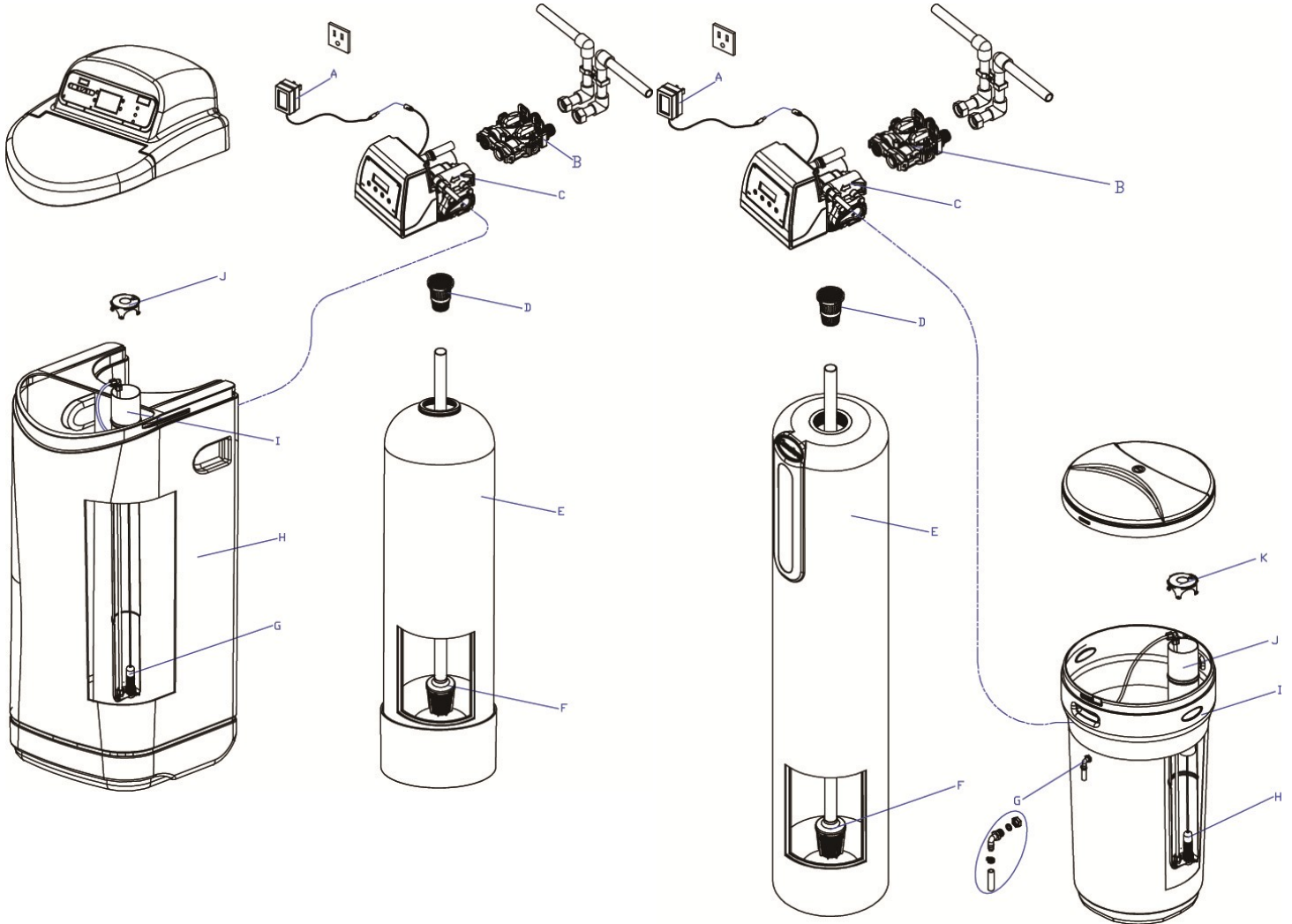

REPLACEMENT PARTS - CABINET			
Replacement Part Number	Part Description	DWG #	Quantity
60010052	POWER TRANSFORMER 120V-12V	A	1
60010002	BYPASS / METER	B	1
10010061	485 UP FLOW VALVE	C	1
60010048	TOP CONE	D	1
25020041	935 TANK (75)	E	1
25020042	1035 TANK (100)	E	1
50010005	DISTRIBUTOR 1X54	F	1
55010023	SAFETY / AIR CHECK ASSEMBLY	G	1
CONTACT FACTORY	CABINET TANK	H	1
55010010	BRINE WELL & CAP	I&J	1

REPLACEMENT PARTS - TWIN TANK			
Replacement Part Number	Part Description	DWG #	Quantity
60010052	POWER TRANSFORMER 120V-12V	A	1
60010002	BYPASS / METER	B	1
10010060	485 UP FLOW VALVE	C	1
60010048	TOP CONE	D	1
25020041	844 TANK (75)	E	1
25020042	948 TANK (100)	E	1
25020043	1054 TANK (150)	E	1
25010058	1252 TANK (200)	E	1
25030007	1465 TANK (300)	E	1
50010005	DISTRIBUTOR 1X54	F	1
60010005	OVER FLOW FITTING ASSEMBLY	G	1
55010023	SAFETY / AIR CHECK ASSEMBLY	H	1
30020006	BRINE TANK BTR-100 (75,100,150)	I	1
30020011	BRINE TANK BTR-145 (200)	I	1
30020032	BRINE TANK BTR-200 (300)	I	1
55010010	BRINE WELL & CAP	J&K	1

## Main Repair Parts - Connectors

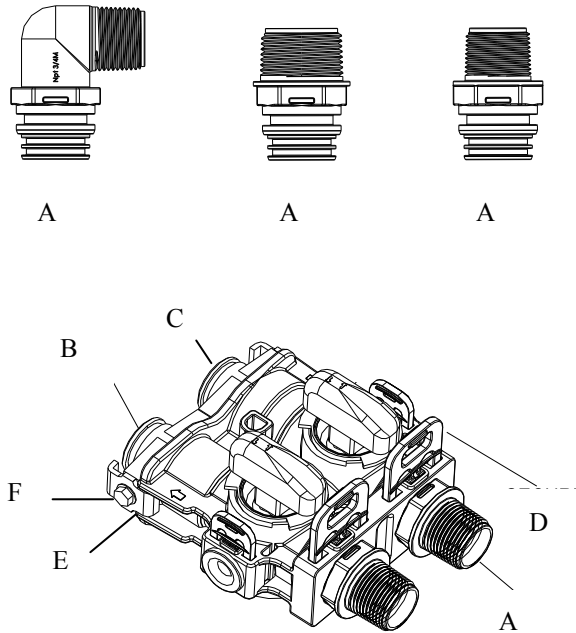

REPLACEMENT PARTS - CONNECTORS			
Replacement Part Number	Part Description	DWG #	Quantity
60010020	3/4" NPT ELBOW	A	2
60010019	1" NPT STRAIGHT	A	2
60010023	3/4" NPT STRAIGHT	A	2
60010079	VALVE COUPLING INLET	B	1
60010101	VALVE COUPLING OUTLET (METER SIDE)	C	1
60010025	PLASTIC SECURE CLIP	D	2
60010046	BYPASS SS CLIP	E	2
60010047	BYPASS SS SCREW	F	2

## Control Valve Exploded View

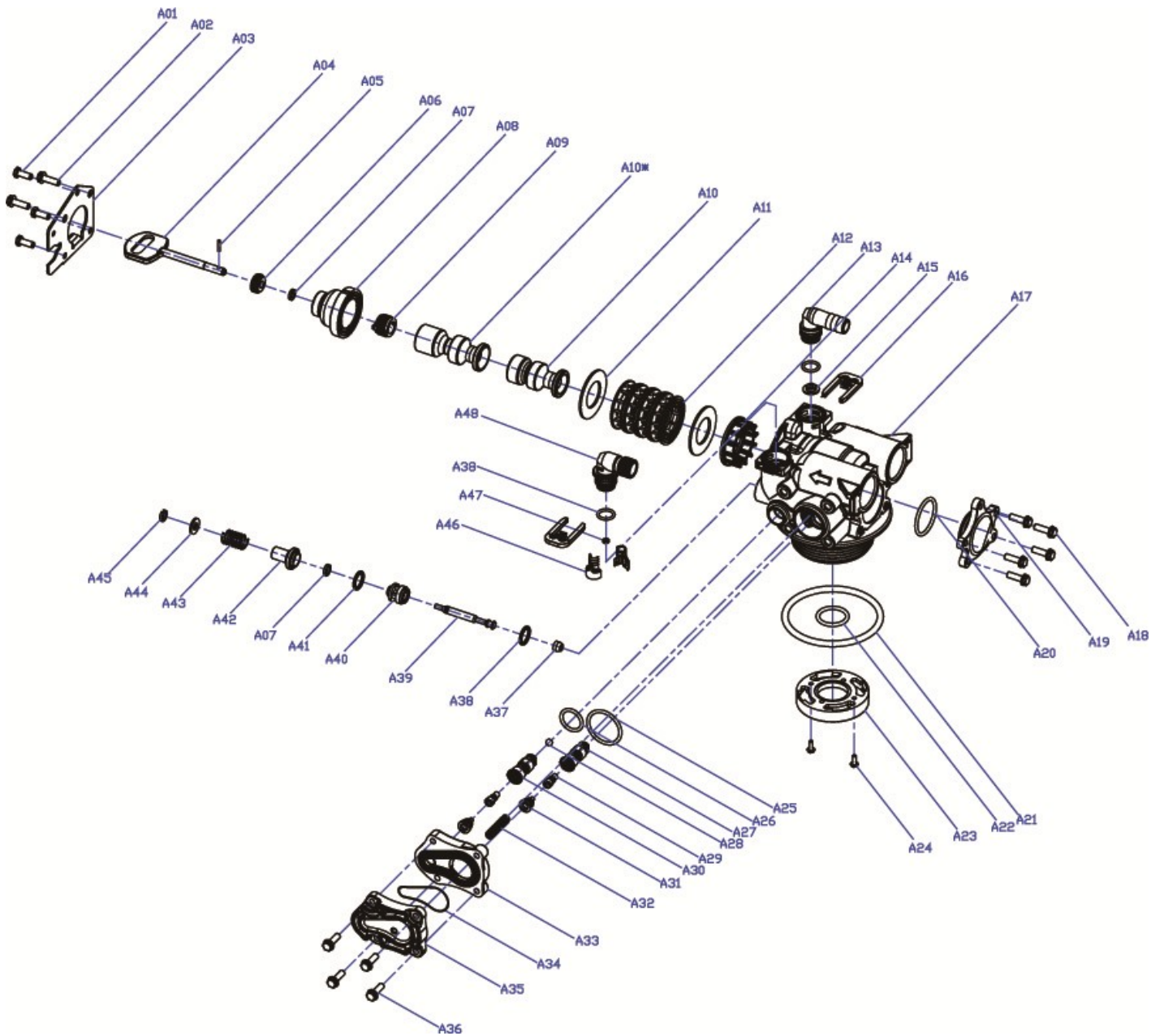

### VALVE REPAIR PARTS LIST

Replacement Part Number	Part Description	Replacement Part Number	Part Description
60010127	INJECTOR SET #0000 BLACK	60010129	85HE UPFLOW PISTON ASSEMBLY
60010126	INJECTOR SET #000 GREY	60010171	85HE DOWNFLOW PISTON ASSEMBLY
60010035	INJECTOR SET #00 VIOLET	60010130	85HE SEAL & SPACER KIT
60010034	INJECTOR SET #0 RED	60010131	85HE DLFC #1 1.5 GPM
60010033	INJECTOR SET #1 WHITE	60010132	85HE DLFC #2 2.0 GPM
60010032	INJECTOR SET #2 BLUE	60010133	85HE DLFC #3 2.4 GPM
60010031	INJECTOR SET #3 YELLOW	60010135	85HE DLFC #5 3.5 GPM
60010128	BLFC 0.2 GPM	60010136	85HE DLFC #A 5.0 GPM
60010110	BLFC 0.3 GPM	60010137	85HE DLFC #B 7.0 GPM
60010082	BLFC 0.7 GPM	60010138	85HE DLFC #C 10.0 GPM

## Control Valve Parts List

485HE CONTROL VALVE (UPFLOW)				
Replacement Part Number	MFG Part Number	Part Description	DWG #	Quantity
	5056087	Screw-M5x12(Hexagon)	A01	3
	5056088	Screw-M5x16(Hexagon With Washer)	A02	2
	5056047	End Plug Retainer	A03	1
	5031016	BNT85HE Piston Rod	A04	1
	5056097	Piston Pin	A05	1
	5031015	BNT85HE Quad Ring Plug Cover	A06	1
	5056070	Quad Ring	A07	2
	5031011	BNT85HE End Plug	A08	1
	5031014	BNT85HE Piston Retainer	A09	1
	5057002	BNT85HE Piston(Electrical Upflow)	A10*	1
	5056073	Seal	A11	5
	5056021	Spacer	A12	4
	5010082	Drain Fitting-B	A13	1
	5031005	BNT85HE Spacer	A14	1
	5056186	DLFC-2#	A15	1
	5056172	Secure Clip-s	A16	2
	5031002	BNT85HE Valve Body	A17	1
	5056508	Screw-M5x12(Hexagon With Washer)	A18	5
	5030004	BNT85 End Cover	A19	1
	5030013	O-Ring- $\phi$ 30 $\times$ 2.65	A20	1
	5056063	O-Ring- $\phi$ 78.74 $\times$ 5.33	A21	1
	26010103	O-Ring- $\phi$ 25 $\times$ 3.55	A22	1
	7060007	Valve Bottom Connector	A23	1
	13000426	Screw-ST2.9X13(Large Washer)	A24	2
	5031022	O-Ring- $\phi$ 32 $\times$ 3	A25	1
	5031021	O-Ring- $\phi$ 18 $\times$ 3	A26	1
	5031013	Injector Plug Body	A27	1
	30040089	Injector Throat	A29	2
	5031012	BNT85HE Injector Fixed Sleeve	A30	1
	30040090	Injector Nozzle	A31	2
	5056103	Injector Screen	A32	1
	5031003	BNT85HE Injector Cover Body	A33	1
	5031018	O-Ring- $\phi$ 40 $\times$ 2.65	A34	1
	5031004	BNT85HE Injector Cover Cap	A35	1
	5031027	Screw-M5x25(Hexagon With Washer)	A36	4
	5056075	Seal Mat	A37	1
	5056134	O-Ring- $\phi$ 12 $\times$ 2	A38	3
	5056054	Injector Stem	A39	1
	5056031	Injector Spacer	A40	1
	5056081	O-Ring- $\phi$ 12.5 $\times$ 1.8	A41	1
	5056030	Injector Cap	A42	1
	5056093	Injector Screen	A43	1
	5010049	Special Washer	A44	1
	5056105	Retaining Ring	A45	1
	5031010	BNT85HE BLFC Fixed Sleeve	A46	2
	5056076	BLFC-2#	A47	1
	5005629	Injector Fitting(3/8".Elbow)	A48	1



# Power Head Exploded View

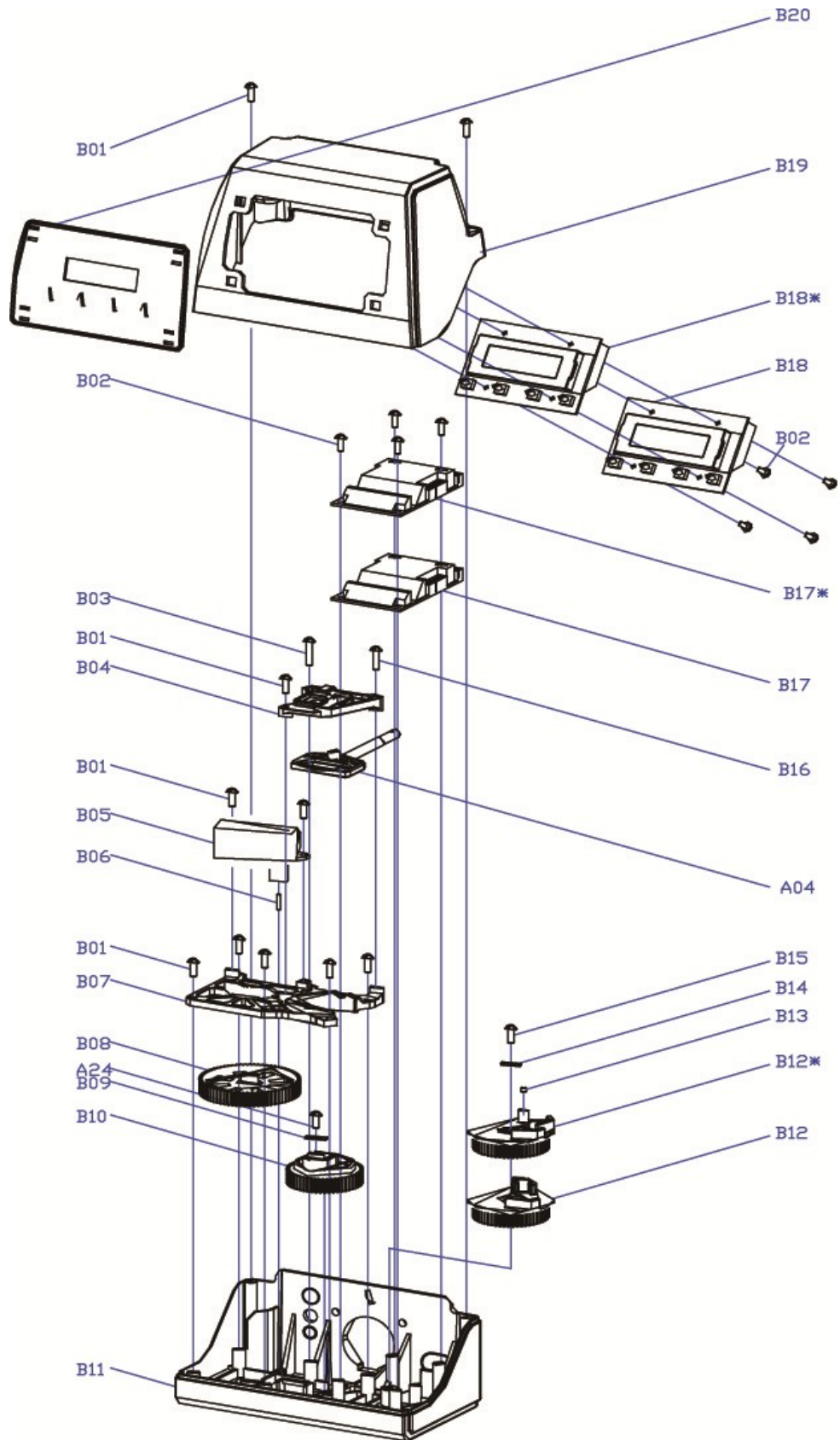

## Power Head Parts List

485HE POWER HEAD (UPFLOW)				
Replacement Part Number	MFG Part Number	Part Description	DWG #	Quantity
	5056084	Screw-ST3.5X13	B01	10
	5010037	Screw-ST2.9X10	B02	9
	13000416	Screw-ST3.5X25	B03	1
	5031007	BNT85HE Piston Rod Guide Plate	B04	1
	5056510	Motor-12v/2rpm	B05	1
	5030014	Motor Power Cable		1
	11700005	Wire Connector		2
	5056098	Motor Pin	B06	1
	5031006	BNT85HE Mounting Plate	B07	1
	5030009	BNT85 Drive Gear	B08	1
	13000426	Screw-ST2.9X13(Large Washer)	A24	2
	5056139	Washer-3x13	B09	1
	5030007	BNT85 Main Gear	B10	1
	5030005	BNT85 Mounting	B11	1
	5031009	BNT85HE Brine Gear(Upflow)	B12*	1
	5010023	Magnet(3x2.7)	B13	1
	5056141	Washer-4x12	B14	1
	5056166	Screw-ST4.2X12(Large Washer)	B15	1
	5031016	BNT85HE Piston Rod	A04	1
	5010036	Screw-ST3.5X16	B16	1
	5031025	BNT85HE Main Pcb(Upflow)	B17*	1
	5010031	Meter Assembly		1
	5010046	Meter Strain Relief		1
	5010029	Power Cable		1
	5010035	Power Strain Relief		1
	19010105	Wire Rope-3x100		2
	5031023	BNT85HE PCB (Upflow)	B18*	1
	5030021	BNT85 Wiring Harness		1
	5030032	BNT185 Cover(Novo)	B19	1
	5030033	BNT185 Display Plate(Novo)	B20	1

## Trouble Shooting

Issue	Possible Cause	Possible Solution
A. Unit fails to initiate a regeneration cycle.	1. No power supply.	Check electrical service, fuse, etc.
	2. Defective circuit board.	Replace faulty parts.
	3. Power failure.	Reset time of day.
	4. Defective meter.	Replace turbine meter.
B. Water is hard.	1. By-pass valve open.	Close by-pass valve.
	2. Out of salt or salt level below water level.	Add salt to tank.
	3. Plugged injector / screen.	Clean parts.
	4. Flow of water blocked to brine tank.	Check brine tank refill rate.
	5. Hard water in hot water tank.	Repeat flushing of hot water tank required.
	6. Leak between valve and central tube.	Check if central tube is cracked or o-ring is damaged. Replace faulty parts.
	7. Internal valve leak.	Replace valve seals, spacer, and piston assembly.
	8. Reserve capacity setting too low.	Increase reserve capacity.
	9. Not enough capacity.	Increase salt dosage.
C. Salt use is high.	1. Refill time is too high.	Check refill time setting.
	2. Defective flow control.	Replace.
D. Low water pressure.	1. Iron or scale build up in line feeding unit.	Clean pipes.
	2. Iron build up inside valve or tank.	Clean control and add resin cleaner to clean bed. Increase regeneration frequency.
	3. Inlet of control plugged due to foreign material.	Remove piston and clean control valve.
	4. Deteriorated resin. (Maybe caused from high chlorine or chloramines.)	Re-bed unit. Consider adding carbon pre-treatment.
E. Resin in drain line.	1. Air in water system.	Check well system for proper air eliminator control.
	2. Incorrect drain line flow control (DLFC) button.	Check for proper flow rate.
F. Too much water in brine tank.	1. Plugged injector or screen.	Clean parts.
	2. Valve not regenerating.	Replace circuit board, motor, or control.
	3. Foreign material in brine valve.	Clean parts.
	4. Unit not drawing brine.	Check for vacuum leak in brine line connections.
G. Unit fails to draw brine.	1. Drain line flow control is plugged.	Clean parts.
	2. Injector or screen is plugged.	Clean parts.
	3. Inlet pressure too low.	Increase pressure to 25 PSI.
	4. Internal valve leak.	Replace seals, spacers, and piston assembly.
	5. Safety valve closed.	Check for leak in brine line connections. Replace safety float assembly.
	6. Vacuum leak in brine line.	Check for leak in brine line connections. Tighten all connections.
	7. Drain line has kink in it or is blocked.	Check drain line.
H. Valve continuously cycles.	1. Defective position sensor PCB.	Replace faulty parts.
I. Flow to drain continuously.	1. Valve settings incorrect.	Check valve settings.
	2. Foreign material in control valve.	Clean control.
	3. Internal leak.	Replace seals, spacers, and piston assembly.
	4. Piston is stuck in position. Motor may have failed or gears have jammed or disengaged.	Check for power to motor. Check for loose wire. Check for jammed gears or gears disengaged. Replace faulty parts.
J. Valve makes beeping sound.	1. The piston has not advanced to the next cycle position properly.	Check for power to motor. Check for loose wire. Check for jammed gears or gears disengaged.

## Warranty

**Novo Water Conditioning Products** warrants that your new water conditioner is built of quality material and workmanship. When properly installed and maintained, it will give years of trouble free service.

### **Seven Year Complete Parts Guarantee**

**Novo Water Conditioning Products** will replace any part which fails within 84 months from date of manufacture, as indicated by the serial number, provided the failure is due to a defect in material or workmanship. The only exception shall be when proof of purchase or installation is provided and then the warranty period shall be from the date thereof.

### **Life Time Warranty on Mineral Tanks and Brine Tanks**

Novo Water Conditioning Products will provide a replacement mineral tank or brine tank to any original equipment purchaser in possession of a tank that fails provided that the water conditioner is at all times operated in accordance with specifications and not subject to freezing.

### **General Provisions**

Novo Water Conditioning Products assumes no responsibility for consequential damage, labour or expense incurred as a result of a defect or for failure to meet the terms of these guarantees because of circumstances beyond its control.

Novo Water Conditioning is a Division of Canature North America Inc.