

Revised August 2013

Serial Number:

BRIGGS IRRIGATION
Operators Manual & Parts Manual
For
Hosereel Mounted Boom
Irrigators
R18, R24 & R30



Briggs Irrigation
Boyle Road
CORBY
Northamptonshire
NN17 5XU

Tel: 00 44 (0)1536 260338
Fax: 00 44 (0)1536 263972
enquiries@briggsirrigation.co.uk
www.briggsirrigation.co.uk

EC DECLARATION OF CONFORMITY

MANUFACTURER

Briggs (UK) Limited
Boyle Road
Corby
Northamptonshire
NN17 5XU
England

Tel: + 44 (0) 1536 260338
Fax: + 44 (0) 1536 263972
Email: enquiries@briggsirrigation.co.uk
Web: www.briggsirrigation.co.uk

HOSE REEL BOOM

MODEL :

TYPE :

This machine complies to

BS EN292
Part 2 1991
(89/392/EEC)

Signed on behalf of Briggs (UK) Ltd



.....

A M Colwill

Director

List of Contents	Page
EC Declaration of Conformity	1
Introduction, Specification	3
Transport, Assembly & Commissioning	4
Positioning the R18, 24, 30 for Operation	4
Folding the Boom	5
Unfolding & Folding Procedure Schematic Drawing	6
Maintenance	6
Risks & Precautions	6
Nelson 10 psi regulated S3000 flow chart	7
Nelson 20 psi regulated S3000 flow chart	8
Nelson 30 psi regulated S3000 flow chart	9
S3000 Spinner	10
SIME JUMBO Teso 6° Sector Sprinkler	11
SIME K1 Teso 8° Sector Sprinkler	12
Nelson Pressure Regulators	13
Hose Reel wind in speed/application rate chart for R18 (24m)	14
Hose Reel wind in speed/application rate chart for R24 (30m)	14
Hose Reel wind in speed/application rate chart for R30 (36m & 48m)	15
<u>SPARE PARTS LIST</u>	16
Figure 1. Chassis	17-18
Figure 2. Centre Section	19-20
Figure 3. First Section	21-22
Figure 4. Second Section (R24 & R30 only)	23-24
Figure 5. R30 End Section	25-26
Figure 6. R24 End Section	27-28
Figure 7. R18 End Section	29-30
Figure 8. Nelson Pressure Regulator and S3000 Spray Jet	31-32
Figure 9. SIME JUMBO Teso 6° Sector Sprinkler	33
Figure 10. SIME K1 Teso 8° Sector Sprinkler	34
Figure 11. R18, R24 or R30 Lift Frame Kit for Briggs Range of Hose Reels	35-36

This manual covers the Briggs R18/R24/R30 hosereel mounted boom range.

TRANSPORT

The transport dimensions are as follows:

<u>DIMENSIONS</u>	<u>R18</u>	<u>R24 & R30</u>
TOTAL FOLDED LENGTH	5.0 metres	5.0 metres
FOLDED WIDTH	2.9 metres	3.3 metres
TRACK WIDTH	1.52 - 4.0 metres	1.52 - 4.0 metres

If necessary the outer boom sections should be removed from the boom to meet local transport width regulations. Wide load safety triangles must be fitted and the Boom sections **must** be roped together for added safety.

Important

Do not exceed 10 km/hr when towing. Excessive speed causes instability due to the Hose Reel rigid chassis design and high centre of gravity.

ASSEMBLY & COMMISSIONING

The Hose Reel mounted boom has been fully flushed and pressure tested at the Briggs Irrigation Factory.

Some parts are removed to make transportation of the boom from factory to site both safe and legal. All parts which have been removed have been number matched and should be carefully assembled ensuring the numbers are in the correct order.

For commissioning, position the Hose Reel and Boom for initial setting up as explained below:

POSITIONING THE BOOM FOR OPERATION

- 1 Tow Hose Reel into the position required to start the irrigation run.
- 2 Turn the drum of the hose reel on the turntable to line up with the centre of the irrigation run (see photograph below).



- 3 Set the wheel track of the boom. This is done manually by loosening the locking bolts and sliding the wheel mounting legs out to the desired position. The locking bolts must be done up tightly to ensure there is no movement during the course of the run. The wheels can be set to span up to a width of 4m.
- 4 Lower the boom by operating the Hose Reel hydraulic leg/lift frame system.
- 5 Unlock the Boom support bracket on the hosereel and unfold the group of sections on one side only and lock securely in position, repeat for opposite side. (page 6 action 3 - this shows the sections being opened on the left hand side of the boom)
- 6 Prepare hosereel for pulling out - Refer to Hose Reel manual.
- 7 Connect the tractor to the towing out bar on the boom and pull out the hose at a constant speed not exceeding 3km/h.
- 8 Once pulled out, remove the tractor and move it at least 6m to provide sufficient clearance for opening the boom sections.
- 9 On the highest side of the boom, open the 1st section boom support bracket and unfold the second section (end section on an R18), and lock it in place (page 6 action 2 – left hand side shown). Open the end section and lock in place (R24 and R30 only) (page 6 action 1).
- 10 Repeat for the opposite side of the boom.
- 11 The quadrant locking system allows the boom to be set at any angle in relation to the direction of the run to suit angled headlands. If starting a run with the boom angled to suit a headland, ensure that it is set to the finishing headland in good time so that an end section does not protrude over a road or a track. Note, the position of the 180° spray jet on the centre section must face away from the Hose Reel to avoid watering in front of the boom.

The boom is now ready for operation. Slowly open the hydrant, Hose Reel valves and start the pump. Engage the Hose Reel drive and set the wind in speed (see pages 14 and 15 for the Hose Reel Wind in Speed charts).

FOLDING THE BOOM

1. Fold outer section (end section) on the lower side of the mini-boom into the second section and lock in the boom support bracket (see action 1 on page 6). Repeat for the second section (action 2). Note on the R18, the end section locks into the boom support bracket on the first section.
2. Repeat this on the other side of the irrigator.
3. Turn the hose drum on the Hose Reel turntable to line up with the centre of the boom.
4. Make sure the backstop is in on R range Hose Reels and the gear lever is in the neutral position on the VR3 & 4 (this will prevent the hose from becoming loose on the Hose Reel) and will also ensure that the mini-boom is positioned correctly on the lift frame. If this is not correct, wind in the hose on the Hose Reel using the p.t.o. handle provided.
5. Fold the first section around the Hose Reel and clamp into the Hose Reel Boom support bracket (action 3). Repeat for the opposite side.
6. Raise the hydraulic legs/lift frame system.
7. Rotate the drum to the central position and reposition the Hose Reel for the next irrigation run.

Unfolding and Folding Procedures for the R18, R24 and R30

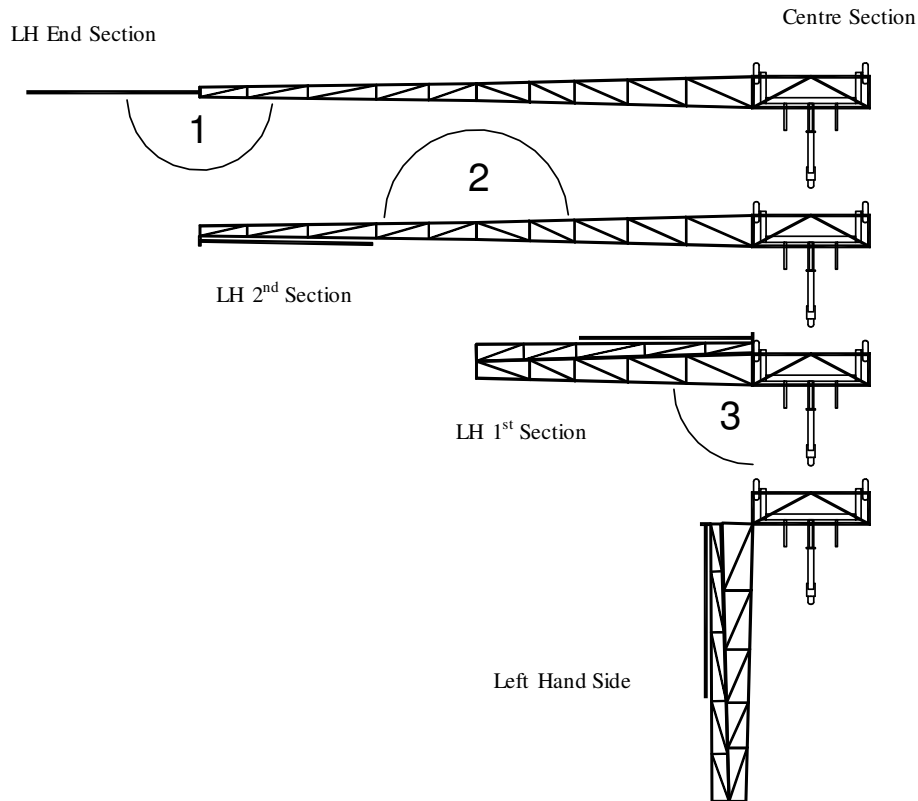

MAINTENANCE

1. Grease the turntable weekly.
2. Grease the rear wheel bearings weekly and repack / adjust annually.
3. Grease the front wheel acetyl bushes weekly on both sides, rotate wheel while greasing.
4. Grease front wheel steering king pin weekly.
5. Ensure Boom support brackets are holding the Boom centrally. Adjust if necessary.
6. Boom locking joint tension must be checked regularly and is adjusted by slackening the locking bolt and turning the offset catch cam. Keep regularly greased for ease of operation.

RISKS AND PRECAUTIONS

- Ensure all locking pins are fully closed on the boom support brackets when transporting or pulling out the boom.
- Always transport the boom with great caution both on the road and in the field.
- Always secure Booms together with ropes or straps, together with the turntable pin when moving on public roads.
- Watch out for turning clearance of the Boom section when manoeuvring around vehicles or any other objects.
- When operating with obstacles in the field (poles etc) ensure the operator is present to “rotate” the Boom around the obstacle.
- If starting a run with the Boom angled to suit a headland, ensure it is set to the finishing headland angle in good time so an end section does not protrude over a road or track.

10psi Spray Head Performance Chart IMP GPM/ M³/hr

3TN Nozzle Sizes (Revised 29/04/99)

<i>Base PSi</i>	#24	#25	#26	#27	#28	#29	#30	#31	#32	#33	#34
<i>Colour</i>	red	red	white	white	blue	blue	dark brown	dark brown	orange	orange	dark green
10	2.64 0.72	2.86 0.78	3.1 0.85	3.34 0.91	3.58 0.98	3.84 1.05	4.11 1.12	4.38 1.2	4.66 1.27	4.96 1.35	5.25 1.43
<i>Base PSi</i>	#35	#36	#37	#38	#40	#42	#44	#46	#48	#50	
<i>Colour</i>	dark green	purple	purple	black	dark turquoise	mustard	maroon	cream	dark blue	copper	
10	5.56 1.52	5.88 1.61	6.2 1.7	6.53 1.78	7.23 1.97	7.93 2.17	8.7 2.4	9.4 2.57	10.3 2.81	11.12 3.04	

20 PSi Spray Head Performance Chart IMP GPM/ M³/hr

3TN Nozzle Sizes (Revised 29/04/99)

<i>Base PSi</i>	#24	#25	#26	#27	#28	#29	#30	#31	#32	#33	#34
<i>Colour</i>	red	red	white	white	blue	blue	dark brown	dark brown	orange	orange	dark green
20	3.7 <i>1.01</i>	4.0 <i>1.1</i>	4.4 <i>1.19</i>	4.7 <i>1.28</i>	5.1 <i>1.39</i>	5.4 <i>1.48</i>	5.8 <i>1.59</i>	6.2 <i>1.83</i>	6.6 <i>1.81</i>	7.1 <i>1.93</i>	7.5 <i>2.05</i>
<i>Base PSi</i>	#35	#36	#37	#38	#40	#42	#44	#46	#48	#50	
<i>Colour</i>	dark green	purple	purple	black	dark turquoise	mustard	maroon	cream	dark blue	copper	
20	7.9 <i>2.16</i>	8.3 <i>2.27</i>	8.9 <i>2.42</i>	9.4 <i>2.56</i>	10.4 <i>2.84</i>	11.6 <i>3.15</i>	12.7 <i>3.45</i>	13.9 <i>3.78</i>	15.2 <i>4.13</i>	16.4 <i>4.74</i>	

30 PSi Spray Head Performance Chart IMP GPM/ M³/hr

3TN Nozzle Sizes (Revised 29/04/99)

<i>Base PSi</i>	#24	#25	#26	#27	#28	#29	#30	#31	#32	#33	#34
<i>Colour</i>	red	red	white	white	blue	blue	dark brown	dark brown	orange	orange	dark green
30	4.6 <i>1.24</i>	4.9 <i>1.34</i>	5.3 <i>1.46</i>	5.7 <i>1.56</i>	6.2 <i>1.7</i>	6.7 <i>1.82</i>	7.1 <i>1.94</i>	7.6 <i>2.06</i>	8.1 <i>2.22</i>	8.7 <i>2.36</i>	9.2 <i>2.51</i>
<i>Base PSi</i>	#35	#36	#37	#38	#40	#42	#44	#46	#48	#50	
<i>Colour</i>	dark green	purple	purple	black	dark turquoise	mustard	maroon	cream	dark blue	copper	
30	9.7 <i>2.65</i>	10.2 <i>2.78</i>	10.9 <i>2.97</i>	11.5 <i>3.14</i>	12.8 <i>3.49</i>	14.2 <i>3.86</i>	15.5 <i>4.23</i>	17.0 <i>4.63</i>	18.6 <i>5.06</i>	20.1 <i>5.47</i>	



S3000 Spinner

Gentle, rain-like droplets - ideal for sensitive soils and crops.

- Very low pressure operation
- Excellent uniformity
- Good wind-fighting capability

FASTER, EASIER NOZZLE CLEANING AND CHANGING:

A quick change adapter allows removal of the sprinkler for easy cleaning of a plugged nozzle without tools and without shutting down the system

3/4" adapter



3TN Nozzle



Spinner Body



Spinner Plates

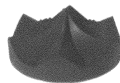

Spinner Cap Assembly

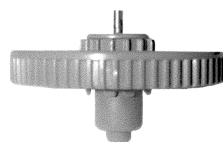

NEW "USER FRIENDLY" PACKAGING SYSTEM:

Nelson 3000 Series sprinklers and 3TN nozzles are packaged for faster, easier and more accurate installation in the field.

NOZZLE SIZE (128th inch increments)
(eg 27/128th inch orifice size)

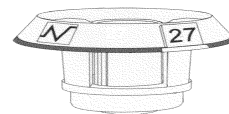

COLOUR STRIPE
(odd numbered nozzles have a colour stripe of the next size)



SIME Jumbo 6°

Sector Sprinkler

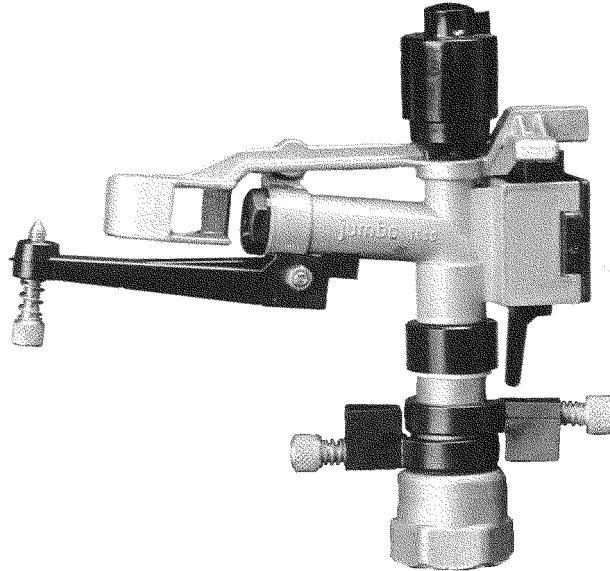

This is a sprinkler of low discharge operating over either full or part circles and comes equipped with various interchangeable nozzles and adjustable jet breakers.

NOZZLE RANGE 5 - 7 mm				
Nozzle Dia (mm)	Pressure (Bar)	Jet Length (m)	Capacity	
			(m ³ /hr)	(Gal/min)
5	3	9.5	1.6	5.9
	4	10	1.9	7.0
6	3	10	2.3	8.4
	4	11	2.7	9.9
7	3	11	3.1	11.4
	4	12	3.6	13.2

SIME K1 Teso 8°

Sector Sprinkler

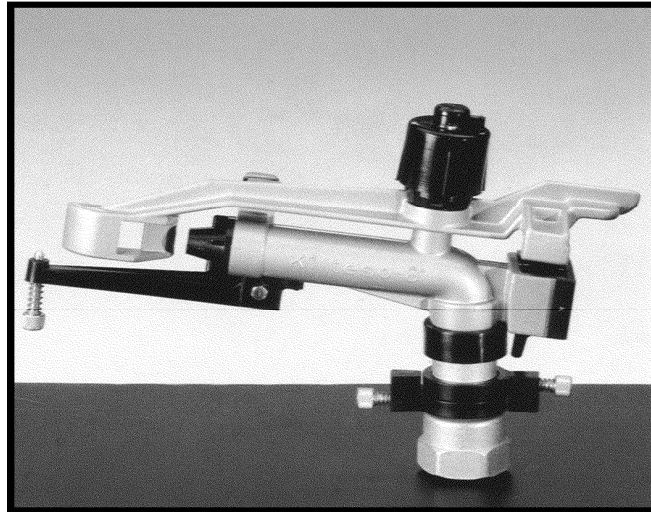

This is a sprinkler of medium discharge that operates over a full or a part circle. It is equipped with various interchangeable nozzles and an adjustable jet breaker.

NOZZLE RANGE 7 – 14 mm				
Nozzle Dia (mm)	Pressure (Bar)	Jet Length (m)	Capacity	
			(m ³ /hr)	(Gal/min)
7	3	13.5	3.1	11.3
	4	15	3.7	13.5
8	3	14	4.1	14.9
	4	16	4.8	17.5
9	3	15.5	5.2	18.9
	4	18	6.0	21.9
10	3	16.5	6.4	23.3
	4	19	7.4	27.0

NELSON BLUE TOP PRESSURE REGULATORS

Precision Accuracy in tough field environments

FEATURES:

PATENTED DAMPING SYSTEM

The patented O-Ring Dampening System of all Nelson Pressure Regulators handles severe pressure surges, without creating flow restrictions under working pressures.

EXTENDED FLOW RANGE

The Nelson Lo-Flo Pressure Regulator extends to 10 gpm, providing economical precision.

EXTENDED ACCURACY

Precision components coupled with an internally lubricated o-ring minimize frictional drag and hysteresis.

PLUG RESISTANT DESIGN

An open seat design prevents hair-pinning, debris hangup and plugging of the pressure regulator.

PRECISION MANUFACTURED

Made of the toughest chemically resistant Materials. 100% water tested for accuracy.

BLUE TOP

Colour-Coded Identification

Patented Internal

Dampening System

- Retards Vibration
- Withstands
- Water Hammer

Vented for Below Ground Use

Chemically Resistant Materials

Internally Lubricated O-Ring for Precision Accuracy

Plug Resistant Seat Design

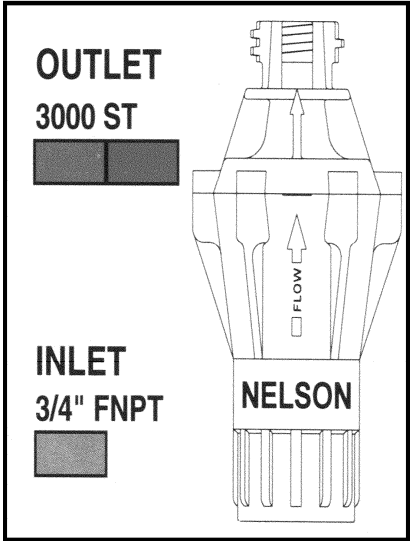
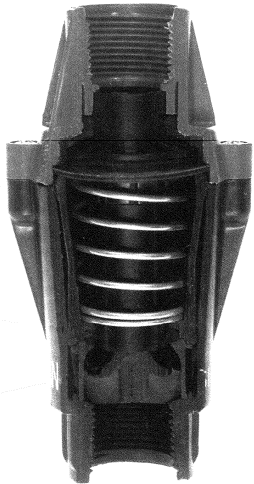

Application Notes

Performance Tables.

Contact the Nelson factory for detailed Performance information.

Statement of

Expected Performance.

Nelson Pressure Regulators are accurate to 6% due to variance of coefficient in manufacturing.

Design Considerations

Maintain a 3 psi threshold above the normal spray rated pressure.

CAUTION!

Pressure regulators should be installed downstream from all shut off valves.

HI FLO			
PSI	BAR	GPM	M ³ /HR
6	.41	4-16	.91-3.63
10	.70	4-16	.91-3.63
15	1.0	2-20	.45-4.54
20	1.4	2-20	.45-4.54
25	1.7	2-20	.45-4.54
30	2.0	2-20	.45-4.54
40	2.8	2-20	.45-4.54
50	3.4	2-20	.45-4.54

Hose Reel Wind in Speed Charts for Application rate range.

Chart Showing Wind In Speeds For Required Application Rate (metres per hour)															
R18 Boom Water Flow - imperial gpm + m ³ /hr Lane Spacing - 24m															
imperial gpm		50	60	70	80	90	100	110	120	130	140	150	160	170	180
m ³ /hr		14	16	19	22	25	27	30	33	36	38	41	44	47	49
APPLICATION RATE	5 mm	114	136	159	182	205	227	250	273	295					
	7.5 mm	76	91	106	121	136	152	167	182	197	212	227	242	258	273
	10 mm	57	68	80	91	102	114	125	136	148	159	170	182	193	205
	12.5 mm	45	55	64	73	82	91	100	109	118	127	136	145	155	164
	15 mm	38	45	53	61	68	76	83	91	98	106	114	121	129	136
	17.5 mm	32	39	45	52	58	65	71	78	84	91	97	104	110	117
	20 mm	28	34	40	45	51	57	62	68	74	80	85	91	97	102
	22.5 mm	25	30	35	40	45	51	56	61	66	71	76	81	86	91
	25 mm	23	27	32	36	41	45	50	55	59	64	68	73	77	82
	27.5 mm	21	25	29	33	37	41	45	50	54	58	62	66	70	74
	30 mm	19	23	27	30	34	38	42	45	49	53	57	61	64	68
	32.5 mm	17	21	24	28	31	35	38	42	45	49	52	56	59	63
	35 mm	16	19	23	26	29	32	36	39	42	45	49	52	55	58
	37.5 mm	15	18	21	24	27	30	33	36	39	42	45	48	52	55
	40 mm	14	17	20	23	26	28	31	34	37	40	43	45	48	51

Chart Showing Wind In Speeds For Required Application Rate (metres per hour)															
R24 Boom Water Flow - imperial gpm + m ³ /hr Lane Spacing - 30m															
imperial gpm		50	60	70	80	90	100	110	120	130	140	150	160	170	180
m ³ /hr		14	16	19	22	25	27	30	33	36	38	41	44	47	49
APPLICATION RATE	5 mm	91	109	127	145	164	182	200	218	236	255	273	291		
	7.5 mm	61	73	85	97	109	121	133	145	158	170	182	194	206	218
	10 mm	45	55	64	73	82	91	100	109	118	127	136	145	155	164
	12.5 mm	36	44	51	58	65	73	80	87	95	102	109	116	124	131
	15 mm	30	36	42	48	55	61	67	73	79	85	91	97	103	109
	17.5 mm	26	31	36	42	47	52	57	62	68	73	78	83	88	93
	20 mm	23	27	32	36	41	45	50	55	59	64	68	73	77	82
	22.5 mm	20	24	28	32	36	40	44	48	53	57	61	65	69	73
	25 mm	18	22	25	29	33	36	40	44	47	51	55	58	62	65
	27.5 mm	17	20	23	26	30	33	36	40	43	46	50	53	56	59
	30 mm	15	18	21	24	27	30	33	36	39	42	45	48	52	55
	32.5 mm	14	17	20	22	25	28	31	34	36	39	42	45	48	50
	35 mm	13	16	18	21	23	26	29	31	34	36	39	42	44	47
	37.5 mm	12	15	17	19	22	24	27	29	32	34	36	39	41	44
	40 mm	11	14	16	18	20	23	25	27	30	32	34	36	39	41

Hose Reel Wind in Speed Charts for Application rate range. (cont.)

Chart Showing Wind In Speeds For Required Application Rate (metres per hour)																
R30 Boom Water Flow - imperial gpm + m ³ /hr Lane Spacing - 36m																
imperial gpm		50	60	70	80	90	100	110	120	130	140	150	160	170	180	
m ³ /hr		14	16	19	22	25	27	30	33	36	38	41	44	47	49	
APPLICATION RATE	5	mm	76	91	106	121	136	152	167	182	197	212	227	242	258	273
	7.5	mm	51	61	71	81	91	101	111	121	131	141	152	162	172	182
	10	mm	38	45	53	61	68	76	83	91	98	106	114	121	129	136
	12.5	mm	30	36	42	48	55	61	67	73	79	85	91	97	103	109
	15	mm	25	30	35	40	45	51	56	61	66	71	76	81	86	91
	17.5	mm	22	26	30	35	39	43	48	52	56	61	65	69	74	78
	20	mm	19	23	27	30	34	38	42	45	49	53	57	61	64	68
	22.5	mm	17	20	24	27	30	34	37	40	44	47	51	54	57	61
	25	mm	15	18	21	24	27	30	33	36	39	42	45	48	52	55
	27.5	mm	14	17	19	22	25	28	30	33	36	39	41	44	47	50
	30	mm	13	15	18	20	23	25	28	30	33	35	38	40	43	45
	32.5	mm	12	14	16	19	21	23	26	28	30	33	35	37	40	42
	35	mm	11	13	15	17	19	22	24	26	28	30	32	35	37	39
	37.5	mm	10	12	14	16	18	20	22	24	26	28	30	32	34	36
40	mm	9	11	13	15	17	19	21	23	25	27	28	30	32	34	

Chart Showing Wind In Speeds For Required Application Rate (metres per hour)																
R30 Boom Water Flow - imperial gpm + m ³ /hr Lane Spacing - 48m																
imperial gpm		50	60	70	80	90	100	110	120	130	140	150	160	170	180	
m ³ /hr		14	16	19	22	25	27	30	33	36	38	41	44	47	49	
APPLICATION RATE	5	mm	57	68	80	91	102	114	125	136	148	159	170	182	193	205
	7.5	mm	38	45	53	61	68	76	83	91	98	106	114	121	129	136
	10	mm	28	34	40	45	51	57	62	68	74	80	85	91	97	102
	12.5	mm	23	27	32	36	41	45	50	55	59	64	68	73	77	82
	15	mm	19	23	27	30	34	38	42	45	49	53	57	61	64	68
	17.5	mm	16	19	23	26	29	32	36	39	42	45	49	52	55	58
	20	mm	14	17	20	23	26	28	31	34	37	40	43	45	48	51
	22.5	mm	13	15	18	20	23	25	28	30	33	35	38	40	43	45
	25	mm	11	14	16	18	20	23	25	27	30	32	34	36	39	41
	27.5	mm	10	12	14	17	19	21	23	25	27	29	31	33	35	37
	30	mm	9	11	13	15	17	19	21	23	25	27	28	30	32	34
	32.5	mm	9	10	12	14	16	17	19	21	23	24	26	28	30	31
	35	mm	8	10	11	13	15	16	18	19	21	23	24	26	28	29
	37.5	mm	8	9	11	12	14	15	17	18	20	21	23	24	26	27
40	mm	7	9	10	11	13	14	16	17	18	20	21	23	24	26	