

Service Manual

Dishwasher
integratable

ADG 955/3 IXM

Model Version		Page
	ADG 955/3 IXM	
	8542 955 10440	
	Technical data	2 - 4
	Spare part list	5 - 6
	Exploded view	7 - 8
	Circuit diagram	9
	Program diagram	10
	Text/Legend	11 - 17
	Family	Global A5

Technical data**Dimension**

Height	82.0-87.0	cm
Width	59.7	cm
Depth	55.5	cm
Weight	56	kg

Wooden door

Thickness min.	16	mm
Thickness max.	20	mm
Width min.	592	mm
Width max.	595	mm
Height min.	515	mm
Height max.	600	mm
Weight max.	5.5	kg
Max. stick out over lower edge of appliance door	92	mm

Electronic boards

Service boards	see spare part list
Serial boards	
UB	4619 720 86171
DB	4619 720 78871
CB	096601
Dataset	096591

Succession of programs

Programs	see program diagram
Succession	1a-3b-4b-5a-6b

Alarms

Refill salt

Options

Delay function
Zone washing

Program information

Start indicator
Prewash
Main wash
Drying
End

Volume (normal program)

Water	Volume	Level
Regeneration	0.3 l	15 mm
Back rinse 3x	1.0 l	68 mm
Prewash	4.8 l	122 mm
Prewash/Zone washing	4.0 l	120 mm
Main wash	4.5 l	121 mm
Main wash/Zone washing	3.5 l	117 mm
Intermediate rinse 1	4.0 l	120 mm
Intermediate rinse 1/ Zone washing	3.5 l	117 mm
Intermediate rinse 2	4.0 l	120 mm
Intermediate rinse 2/ Zone washing	3.5 l	117 mm
Clear rinse	4.0 l	120 mm
Clear rinse/Zone washing	3.5 l	117 mm
Safety / overflow	8.5 l	141 mm

Measuring the level

Remove the coarse sieve, put in a measuring meter into the sump, measure the height of the water level.

Detergent max.

Pre-wash	10	cm ³
Main-wash	45	cm ³
Rinse aid	125	cm ³
6 Dosage steps	1 - 6	ml

Water softener

Saltcontainer	2	kg
Resin container	900	cm ³
Regeneration dosage	300	cm ³

Water pressure

Inlet pressure	0.3-10	bar
Spray pump pressure	0.4	bar

Rotations

Spray pump motor	2800	RPM
Drain pump motor	3000	RPM
Spray arm lower	20 - 40	RPM
Spray arm upper	25 - 35	RPM
Ceiling rotor	45 - 65	RPM

Technical data

Flow rates / Inlet volume

Flow meter (at 0.3 bar = quantity 1.1 l/min)	208	lmp/l
Spray pump	~ 70	l/min
Drain pump	16	l/min
Pump height max.	1.1	m
Inlet valve	4.5	l/min
Valve for Zone washing	30	l/min
Spray arm lower	33	l/min
Sprayarm upper	27	l/min
Ceiling rotor	10	l/min

Electrical data

Base data

Voltage	220/230	V
Frequency	50	Hz
Total power	2.0-2.2	kW
Fuse	10	A

Motor

Spray pump motor

Voltage	230/240	V
Power consumption	160	W
HI	81	Ω
HA	44	Ω
Capacitor	4	μ F

Drain pump motor

Voltage	220/240	V
Power consumption	30	W
Resistance	146	Ω

Heating

1 Element system

Voltage	220/230	V
Power consumption	1.87/2.04	kW
Resistance	24.5	Ω
Heating speed	~ 2.0	$^{\circ}$ C/min
Temperature on surface	~ 115	$^{\circ}$ C
Safety thermostat self reset	85	$^{\circ}$ C

Potentiometer

Points of measurement: 1 (black) to 2 (middle)

Position 0	0.0	k Ω
Position 1	0.5	k Ω
Position 2	1.0	k Ω
Position 3	1.4	k Ω
Position 4	1.8	k Ω
Position 5	2.3	k Ω
Position 6	2.6	k Ω

Water valves

Inlet valve

Voltage	220/240	V
Frequency	50/60	Hz
Resistance	3.76	k Ω

Regenerating valve

Voltage	220/240	V
Frequency	50/60	Hz
Resistance	3.13	k Ω

Valve for zone washing

Voltage	220-240	V
Frequency	50/60	Hz
Resistance	4	k Ω

Coil of dispenser

Voltage	220/240	V
Frequency	50/60	Hz
Resistance	1.5	k Ω

Reedcontact

flow meter
salt control

Technical data**NTC**

15 °C	75	kΩ
20 °C	62	kΩ
30 °C	43	kΩ
40 °C	28	kΩ
50 °C	19	kΩ
60 °C	13	kΩ
70 °C	9	kΩ
80 °C	6	kΩ
85 °C	5	kΩ

Regeneration

Volume	300	cm ³
Position 0 after wash cycles water hardness	10 0-5 0-0.9 0-9	°dh mmol/l °Fh
Position 1 after wash cycles water hardness	8 6-10 1-1.8 10-18	°dh mmol/l °Fh
Position 2 after wash cycles water hardness	6 11-15 1.9-2.7 19-27	°dh mmol/l °Fh
Position 3 after wash cycles water hardness	4 16-21 2.8-3.7 28.37	°dh mmol/l °Fh
Position 4 after wash cycles water hardness	3 22-28 3.8-5.0 38-50	°dh mmol/l °Fh
Position 5 after wash cycles water hardness	2 29-35 5.1-6.3 51-63	°dh mmol/l °Fh
Position 6 after wash cycles water hardness	1 36-60 6.4-10.7 64-107	°dh mmol/l °Fh
Salt consumption for regeneration	77	g
Number of cycles with 2 kg salt	26	

Spare part list

Model **ADG 955 IXM**
Service No. **854295510440**
Version **854295510440**

Pos. No.	12NC Code	Description	Pos. No.	12NC Code	Description
003 0	4812 440 19382	Traverse to 99/27	322 0	4812 453 70523	Insert panel INOX
003 0	4812 440 19594	Traverse from 99/27	322 1	4812 440 19514	Sticker Multizone grey
004 0	4812 440 18952	Drip tray assy	331 0	4812 413 58889	Knob program cpl. BK
004 1	4812 401 18402	Holder	332 0	4812 410 28569	Push button cap BK
011 0	4812 505 18369	Foot long	350 0	4819 310 39832	Display board (DB)
011 1	4812 528 98004	Shaft flexible	350 1	4812 381 28024	Lens green
011 2	4812 528 78032	Slide disc f.foot	350 2	4812 381 28025	Lens red
011 3	4812 535 98054	Gear	400 0	4812 361 58126	Motor + spraypump cpl.
011 4	4812 528 98001	Roll f.foot	405 0	4812 360 18371	Spray pump
022 0	4812 440 19398	Side panel left	405 1	4819 515 28158	Gasket
022 1	4812 440 19397	Side panel right	420 0	4812 121 18132	Capacitor
022 2	4812 440 18953	Spacer	421 0	4812 121 18161	Interf.filter
024 0	4812 440 19463	Panel, rear	430 0	4812 360 18357	Pump,draining
040 1	4812 417 18774	Hinge left	430 1	4812 466 68506	Shaft seal
040 2	4812 417 18773	Hinge right	450 0	4812 259 28684	Heating element
044 0	4812 492 38362	Spring f.door	480 0	4812 321 28386	Cable harness set
044 1	4812 492 38364	Spring f.cap	480 1	4812 321 28371	Cable
047 0	4812 404 48591	Brake f.door	480 2	4812 321 28383	Cable 6poles
047 1	4812 401 18397	Band,brake	480 3	4812 401 18418	Protector f.wiring
047 2	4812 404 68023	Hook	490 0	4819 321 18136	Cable,mains 2m
053 0	4819 440 19906	Plinth service kit NoThermod.	490 1	4812 321 28367	Strain relief
103 0	4812 440 19478	Door outer	521 0	4812 214 78251	Control board (CB)
105 0	4812 404 48611	Fastener door	531 0	4812 273 18055	Switch waterhardness
105 2	4812 505 68004	Clip	531 1	4812 273 18056	Wheel,fingertip
120 0	4812 440 19456	Door,inner	571 3	4812 281 28363	Valve f.zone-washing
120 1	4812 440 18969	Batten	575 0	4812 281 28361	Regen.valve
130 0	4812 417 58361	Tilt lock	583 0	4812 271 28407	Switch diaphragm
131 0	4812 401 18416	Hook lock	616 0	4812 281 18047	Contact,reed salt
175 3	4812 466 68532	Batten to 99/01	620 0	4812 218 38081	User board (UB)
175 3	4812 466 68572	Batten from 99/01	623 0	4812 271 38356	Microswitch
191 0	4812 466 68564	Gasket door	633 0	4812 271 38355	Microswitch door
192 0	4812 466 68467	Gasket, door lower	680 0	4812 418 68154	Combidosage
241 0	4812 458 18914	Basket upper straight	680 1	4812 466 68495	Gasket
241 1	4812 458 18324	Holder cups right white	681 1	4812 466 68497	Gasket
241 3	4812 528 88068	Wheel,basket upper (set)	681 2	4812 440 18975	Flap
241 8	4812 466 68553	Spacer cap set	682 0	4812 466 68496	Gasket
242 0	4812 458 18923	Basket lower cpl.	691 0	4812 282 68012	Feeler NTC
242 1	4812 528 88069	Wheel,basket lower	700 0	4812 530 28804	Hose, inlet aqua stop 4,2m
242 2	4812 458 18262	Plate,support f.basket lower	700 0	4812 530 28848	Hose, inlet aqua stop 2m
242 3	4812 458 18275	Plate,support f.basket lower	700 1	4812 480 48019	Sieve
242 4	4812 466 48059	Fixation	700 2	4812 520 58002	Gasket set
243 0	4812 458 18272	Basket cutlery	701 1	4812 310 18153	Yoke clamp set
243 4	4812 458 18317	Bracket	710 0	4812 418 68151	Monoblock
261 0	4819 462 38271	Rail telescope, inner	710 2	4819 310 38536	Threaded ring
261 1	4819 404 48819	Cap rail	710 3	4819 466 69562	Gasket set
261 2	4812 462 78995	Cap rail ahead	714 0	4812 462 78993	Threaded cap
263 0	4819 520 18013	Ball cage cpl.	714 2	4812 440 18963	Cabinet non-return flap
263 1	4812 520 48001	Ball Niro 8 D	716 0	4812 418 68147	Reg.dosage
265 0	4812 404 48637	Basket adjustm. cpl.	716 1	4812 466 68475	Gasket
265 2	4812 404 48638	Grip basket adjustment	716 2	4812 462 78994	Cover
301 0	4812 453 79652	Control panel SILV	721 1	4812 360 68061	Spray arm lower. cpl.
303 1	4812 460 38059	Plate,handle SILV	721 2	4812 466 68491	Gasket 25x2,3B
305 0	4812 440 19464	Batten adjustable SILVER	721 3	4812 466 68558	Gasket 30x3,0
305 1	4819 502 18241	Screw synthetic	721 4	4812 440 19455	Flange
305 2	4819 505 18191	Nut	722 0	4812 360 68044	Spray arm upper

Spare part list

Model ADG 955 IXM
Service No. 854295510440
Version 854295510440

Pos. No.	12NC Code	Description
722 2	4812 360 68056	Hub upper straight cpl.
723 0	4812 360 68049	Spray arm ceiling
723 1	4819 310 39831	Kit
726 0	4812 530 28786	Tube
726 1	4812 530 28787	Tube
726 2	4812 505 18358	Nut
726 3	4812 466 68512	Gasket
726 4	4812 462 79633	Centering
743 0	4812 511 48171	Capacitor
743 1	4812 530 28102	Hose, inlet
743 3	4812 505 18364	Nut
743 4	4812 530 28807	Hose 9x1,5x270+10
743 7	4812 466 68514	Gasket
751 0	4812 418 18205	Water collector
751 1	4819 310 39826	Kit Guidance
755 0	4812 530 28849	Bend
755 2	4812 530 48148	Tray,leak
756 0	4812 360 58099	Floater
761 0	4812 480 58082	Sieve fine
761 2	4812 418 18204	Cover sieve
762 0	4812 480 58084	Microfilter
763 0	4812 480 58083	Sieve coarse
781 0	4812 530 28737	Hose,draining
781 1	4819 530 28286	Sleeve hose
781 2	4819 492 68405	Clip f.non-return valve
781 3	4812 281 28364	Flap non-return
783 1	4812 530 28806	Hose connection
783 5	4812 530 28851	Distributor
783 6	4812 530 28796	Hose 10x3x180+10
791 0	4812 532 68067	Gasket
791 2	4812 530 58093	Gasket
791 4	4812 466 68503	Gasket
791 5	4812 466 68504	Gasket
794 1	4819 530 58032	Gasket 20x2,5
901 0	4822 401 10492	Clamp,hose 14-24 mm
901 1	4812 401 18424	Strap 050,0
901 2	4812 401 18157	Strap 32-50/9 C61
901 4	4812 401 18426	Strap 025,6
901 5	4812 401 48573	Strap 028,6
901 6	4812 401 48574	Strap 038,1
901 7	4812 401 18427	Strap 031,6
901 8	4812 401 18075	Strap 20-32/9 mm
902 1	4812 466 78015	Fastener f.buildt-in models from 99/22
902 1	4812 466 78361	Fastener f.buildt-in models to 99/22
902 2	4812 404 78241	Holder
904 2	4812 462 79657	Cover BK 3,5x5
910 1	4812 502 18394	Screw 3,5x14-H
910 2	4812 502 18363	Screw 4,0x12-H
910 3	4812 502 18389	Screw NIRO A2
910 4	4812 502 18385	Screw M3,5x8-T15M
910 5	4812 502 18393	Screw 3,5x9-1 Tx15
910 7	4812 502 18397	Screw INOX A2 M 5X12
964 1	4812 466 68511	Gasket housing upper to 99/01
964 1	4812 466 68573	Gasket housing upper from 99/01
993 1	4812 466 78018	Foil protection

Pos. No.	12NC Code	Description
993 2	4812 404 48609	Socket wrenc foot
993 5	4822 532 80216	Funnel salt

Exploded view

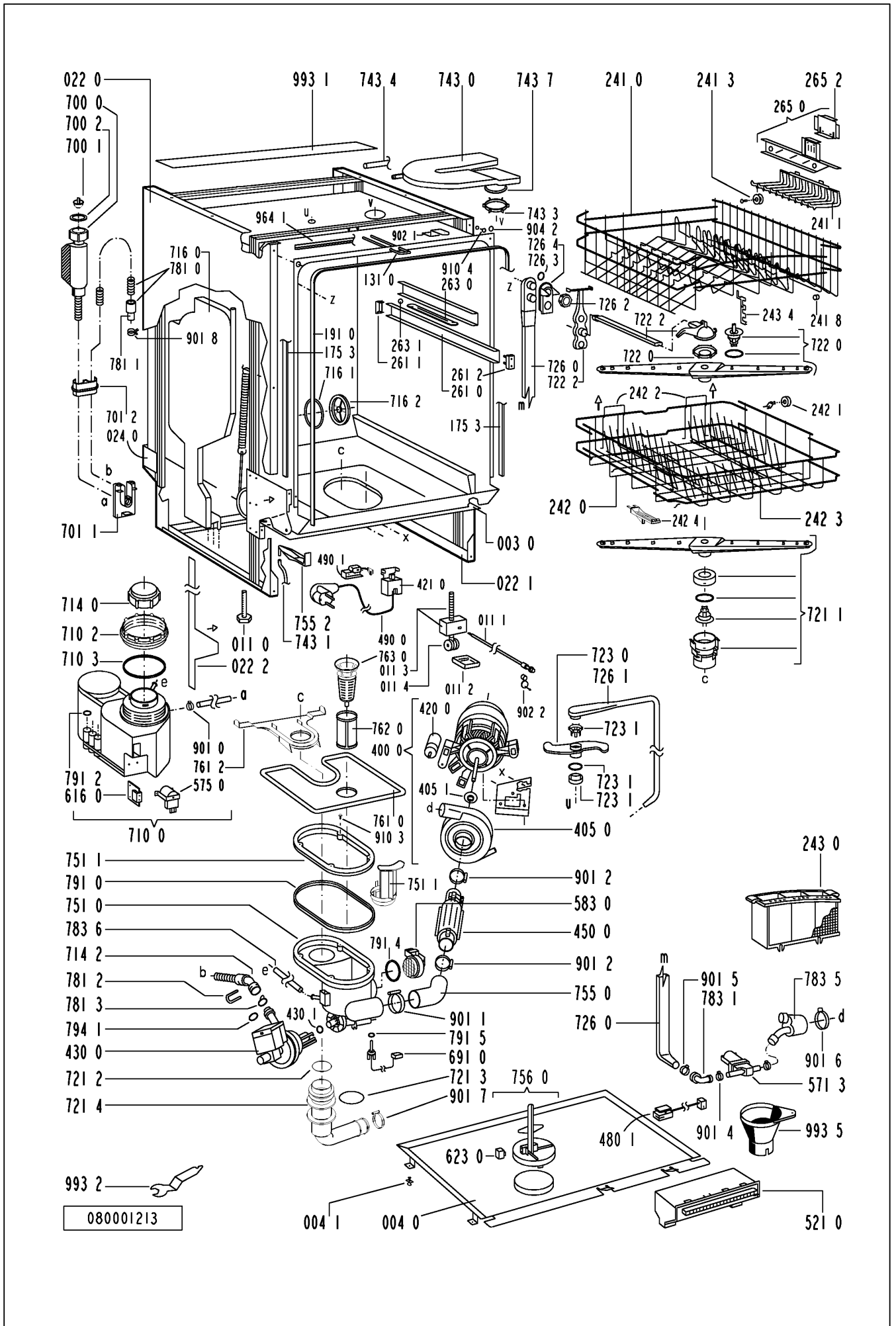

Circuit diagram

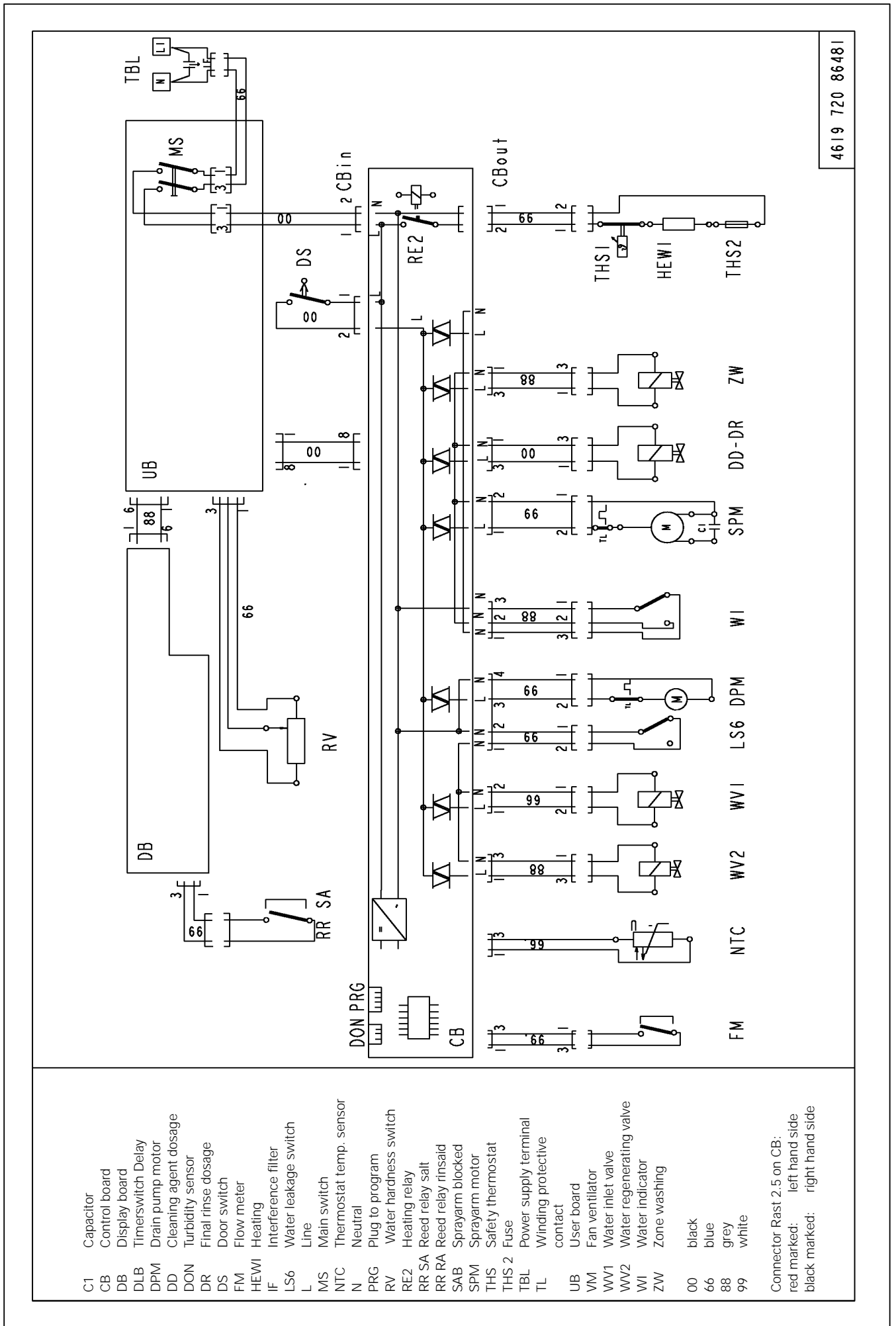

Text/Legend

Test procedure for SERVICE-TEST-PROGRAM DOLPHIN dishwashers (Global)

1. Start the passive test program.
If there is a defective component indicated, open the plinth and take out the control board (CB).
2. Check the component.
Unplug the indicated component from the control board (CB) and check it by using an Ohm-measure equipment.
If the ohms are not correct, check the cables to the component and check the component itself.
3. Check the control board (CB).
4. Only if there is no reaction when pushing a push button or turning the rotary switch, then test the control board (CB) and the user board (UB) with the test points.
5. At the end of the repair start the appliance and delete the stored failure. After this, start the test program again to see that the failure is solved.

More details: s. following pages.

Attention:

First unplug the appliance, then set the connection clamps of the volt measurement on the test points.

Danger for short circuit. Short circuits on components can damage the control board (CB).

If electronic boards are wet, do not switch the appliance on.

For check the appliance, plug in the appliance.

Failures, which occurred during the program will store and indicate by flashing start LED.

Then start the test program without erase the failure before. The failure will indicate.

To erase the failures, you must push the start button longer than 3 seconds.

The failures

- F1 NTC break
- F2 water leakage
- F9 continuous water inlet

are checked and indicated immediately after start of the program.

Therefore these failures have to be solved before starting the active test program.

When these failures are not solved, the active test program does not run.

The electrical components get their voltage via triac from the control board (CB). For testing the volume of voltage the volt meter must be parallel to the component (the component must be connected). If the component is disconnected, then the outcomed voltage from the control board (CB) is reduced.

For appliances with no program indicator or 7-segment-display you can use for testing a display board (DB) in addition. More details : see chapter active test program.

After starting a program this program is locked. That means neither by unplugging/switching of the appliance nor by setting an other program, the first setted program can be changed. Changing of the program is only possible by pushing the start button again for longer than 3 sec.. The programs end with draining out. After that start again.

On appliances with separate On-Off button the last used program is stored. That means if the customer wants to use the same program again he has only to press the On-button and the Start-button.

Attention: On new service control boards the first service test program is without back rinsing. Dangerous for overfilling the appliance, in case the appliance is not empty. By running the test program a second time the back rinsing will be carried out as usual.

Text/Legend

Handling of failures

F0 Sensor failure

Will not indicate for the customer. The programs will finish even there is a failure. The Failure is indicated only in the active test program after 10 – 30 second's. The active test program will finish as well, even there is a failure.

If the failure in a sensor program appear, the machine will always choose the highest consumption (best cleaning result).

- None or wrong output from the sensor
- Unlogical or unreal measurement results

Reason:

- Defective electronic of the sensor
- Optoelectronic parts in the sensor defect
- Case of the sensor is very dirty
- Connection between sensor and control board (CB) interrupted

Attention: The failure code will not store.

F1. NTC break

Temperature out of the normal value (-3°C till +85°C)

- temperature inside higher than +85°C
- NTC defective
- dishwasher is frozen, less than -3°C

Fill in the appliance a cup of warm water to warm it up before you start it, if the temperature is less than -3°C

F2. water leakage

- water is in the drip tray

floaters (LS6) switches off the WW1 and the electronic switches on the DPM till WI reports empty

F3. heating system defective

Indicated after app. 11 minutes (1. check after 5 min., after that follow 2 more checks, before the failure is indicate)

- too less heating speed (lower 1,5 °C in 3 min.)
- heating (HEW) defective
- relays (RE2) on control board (CB) is defective
- NTC - resistance fluctuation
- water indicator (WI) defective (is switched off) - spray pump (SPM) is not working

F4. draining failure

drain pump starts and after 4 min. the WI detects not empty

- drain pump (DPM) defective
- siphon closed
- control board (CB) defective
- water indicator (WI) defective (is switched on)

F5. spray arm blocked (leads not to stop the appliance)

SAB sensor sends less than 10 impulses/min.

- spray arm blocked or not fixed well
- spray pump (SPM) does not work well
- SAB sensor defective

Text/Legend

- F6. water tap closed (only indicated after start of the active test program)
water valve (WV1) is switched on but flow meter (FM) sends no impulses (less than 10 imp. in 10 sec.) and the water indicator (WI) is off (empty)
- water tap closed
 - water inlet hose blocked
 - water inlet valve (WV1) defective
 - flow meter (FM) defective (leads to FM failure)
- F7. flow meter failure
water inlet valve (WV1) is switched on and the water indicator (WI) is on (full).
- flow meter (FM) sends to less impulses (less than 10 imp. in 10 sec.)
 - water tap closed
 - water inlet hose blocked
 - water inlet valve (WV1) defective
 - flow meter (FM) defective
- F8. water level failure
failure monitored during spray pump is on and the water indicator switches back more than 20 times in 2 min.
- water indicator defective (should switch on after app. 1 litre)
 - sieve blocked
 - water strongly foams
 - pot has turned off and is filled with spray water
 - no stable spray pump (SPM) working
- F9. continuous water inlet
water inlet valve (WV1) is switched off, water indicator (WI) on, flow meter (FM) sends impulses (more than 10 imp. in 10 sec.)
- water inlet valve (WV1) mechanically not closed
 - triac (CB) permanently switched on. (short circuit)

reaction: interval 30 sec. draining / 20 sec. tracing

For salt, rinse aid, zone wash valve, sieve valve failure see active test program.

Text/Legend

Appliances FAILURE AND ALARM DISPLAYING CODES

Alarm / Failure	Indication for customer		Indication whitin test program after a failure has occurred	
Sensor-break F 0	○ ○ ○ ○ PS1 PS2 PS3 PS4 START ○		● ● ○ ○ PS1 PS2 PS3 PS4 START ○ (only indicated after start of the active t.p.)	
NTC-break F 1	○ ○ ○ ○ PS1 PS2 PS3 PS4 START ●		● ○ ○ ○ PS1 PS2 PS3 PS4 START ○	
Water Leakage F 2	○ ○ ○ ○ PS1 PS2 PS3 PS4 START ●		○ ● ○ ○ PS1 PS2 PS3 PS4 START ○	
Heating System Failure F 3	○ ○ ○ ○ PS1 PS2 PS3 PS4 START ●		○ ○ ● ○ PS1 PS2 PS3 PS4 START ○	
Draining Failure F 4	○ ○ ○ ○ PS1 PS2 PS3 PS4 START ●		○ ○ ○ ● PS1 PS2 PS3 PS4 START ○	
Spray Arm Blocked F 5	○ ○ ○ ○ PS1 PS2 PS3 PS4 START ○		● ○ ○ ● PS1 PS2 PS3 PS4 START ○	
Water Tap Closed F 6	○ ○ ○ ○ PS1 PS2 PS3 PS4 START ●		○ ● ○ ● PS1 PS2 PS3 PS4 START ○ (only indicated after start of the active t.p. Start LED flashed in passive t.p.)	
Flow Meter Failure F 7	○ ○ ○ ○ PS1 PS2 PS3 PS4 START ●		○ ○ ● ● PS1 PS2 PS3 PS4 START ○	
Water Level Failure F 8	○ ○ ○ ○ PS1 PS2 PS3 PS4 START ●		○ ● ● ○ PS1 PS2 PS3 PS4 START ○	
Water Continuously On F 9	○ ○ ○ ○ PS1 PS2 PS3 PS4 START ●		● ○ ● ○ PS1 PS2 PS3 PS4 START ○	

● Led Flashing PS 1 till PS 4 : Program sequence LED
 ○ Led OFF

Text/Legend

With the passive test program, you can check all LED's and buttons. If there is no failure the passive test program runs normal.

Attention:

If you can't start the active test program (Start button don't flash), normally there is one of the following failures detected: F1, F2 or F9

When these failures are not solved before, the active test program will not run. After solving the failure you must "sign" (erase) the failure.

Start procedure

Passive test program

The passive test program shows the stored failure. If there is no failure the passive test program runs normal.

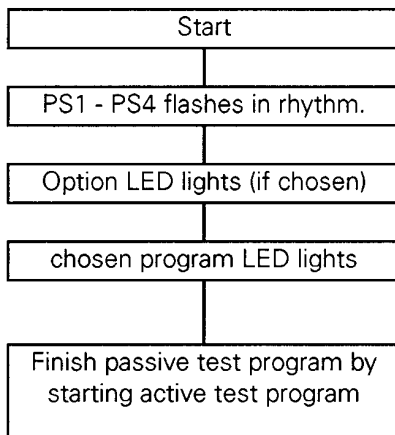

1. Switch off the appliance
2. Push start button and hold it.
3. Choose position 1 of the turning knob turning right side (program 1).
4. Finish pushing the start button when the start LED flashes.
5. Failure indication.
6. Repair the failure
7. Solve the failure by pushing the start button for longer than 3 sec.
8. Start the passive test program again. If there is no failure detected, test all LED's and after that choose program 1.
9. Finish the passive test program by pushing the start button for shorter than 3 sec.

Active test program starts (see next page)

Program sequence LED

PS1	1. LED	prewash	
PS2	2. LED	mainwash	
		intermediate rinse final rinse	
PS3	3. LED	drying (regeneration)	
PS4	4. LED	end	goes off if any button is pushed
			goes off after 30 min progr. is finished

Text/Legend

Active test program

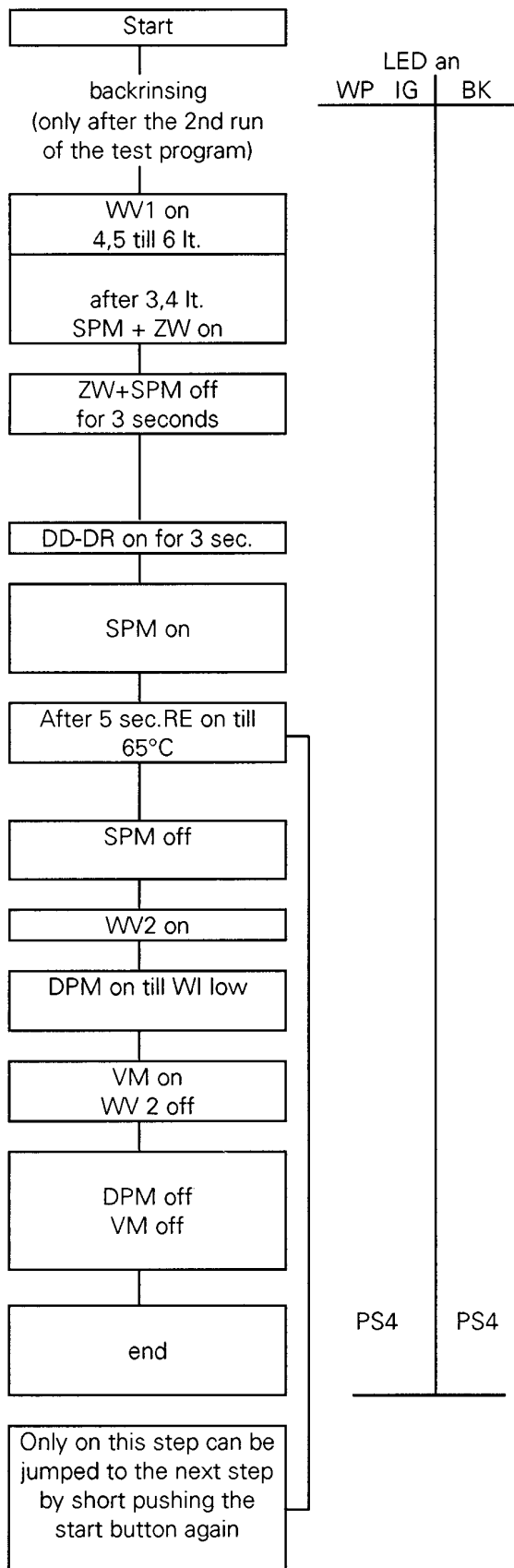

Test procedure

1. Passive test program OK?
no: repair failure, after that solve the failure and start the passive test program again.
yes: push start button shorter than 3 second's
2. Active test program starts.

Remarks

The active test program runs to the failure position and stops or, if there is no failure, to the end.

To leave the test program push the start button for longer than 3 second's.

Too less salt or too less rinse aid leads not to the stop of the appliance.

The function of the zone wash valve can only be checked optically.
A defect leads to a not stable SPM pressure.

Appliances which have no program sequence or no 7-segment-display can't exactly show the failure. On these appliances the failure can only be found by starting the test program and following this by using the program chart or by connecting an additional kit 4819 310 39782 on the user board (UB) (connector DISPL).

When the failure position is reached the flashing start LED goes out.

Attention:
If you can't start the active test program (Start button don't flash), normally there is one of the following failures detected: F1, F2 or F9

When these failures are not solved before, the active test program will not run. After solving the failure you must "sign" (erase) the failure.

Remarks:
ZW on: zone wash valve on = no water on the upper sprayarm.
ZW off: zone wash valve off = water on the upper sprayarm.

Text/Legend

Testpoints on the control board (CB)

With these test points the function of the buttons and the rotary switch can be checked.
 The test points are in the service window on the control board.

For the test fine clamps, cables and volt meter with high input resistance are necessary.

Before setting the clamps on the test points, switch off the appliance.

Testpoints: T0: common line T2: analogue value
 T1: analogue value T3: digital signal

Service window

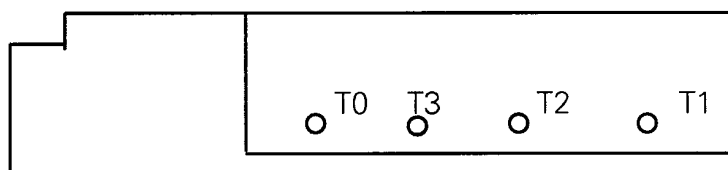

Check: T0 to T1

Communication between control board (CB) and display board (DB) measured over user board (UB)

pushed button	voltage	from	to
no button pushed	ca. - 5.24 V DC	Control board (CB)	Display board (DB)
ZW (1 or 2 LED)	ca. - 3.43 V DC	Display board (DB)	Control board (CB)
Delay	ca. - 2.88 V DC	Display board (DB)	Control board (CB)
ZW + Delay start	ca. - 2.88 V DC	Display board (DB)	Control board (CB)

Check: T0 to T2

Communication between Control board (CB), User board (UB)

	voltage	from	to
Programplace 1	ca. - 1.32 V DC	User board (UB)	Control board (CB)
Programplace 2	ca. - 1.75 V DC	User board (UB)	Control board (CB)
Programplace 3	ca. - 2.20 V DC	User board (UB)	Control board (CB)
Programplace 4	ca. - 2.90 V DC	User board (UB)	Control board (CB)
Programplace 5	ca. - 3.36 V DC	User board (UB)	Control board (CB)
Programplace 6	ca. - 3.80 V DC	User board (UB)	Control board (CB)
Programplace 7	ca. - 4.27 V DC	User board (UB)	Control board (CB)
start button	ca. - 0.00 V DC	User board (UB)	Control board (CB)

Check: T0 to T3:

Communication between Control board (CB) and User board (UB). Check of the 'Start' function
 Select any program.

before start (start LED off)	- 5.24 V DC
after start (start LED on)	- 3.87 V DC

How exact the data are, depends on the measure equipment.