

STK-406 Pet Immunity PIR Motion Detector Installation Manual

Introduction

Thank you for choosing 406 pet immunity motion detectors. As an informed security professional, you've selected a state-of-the-art self-detecting, detection system that incorporates the following unique features:

- Two Dual Element Sensors
- Pet-friendly Lens Pattern
- 100% Digital Motion Detection
- Digital Shield™ algorithm software.
- Digital Auto Pulse Processing (Patented)
- Digital Auto Temperature Compensation
- Metal Shield for RFI/EMI rejection
- Auto Background Analyses
- Comprehensive LED display

Please study this instruction manual carefully to ensure proper installation of the 406.

Do not touch the sensor surface as this could result in detector malfunction. IF NECESSARY, CLEAN THE SENSOR SURFACE USING A SOFT CLOTH WITH PURE ALCOHOL.

DIP Switch Setting

406 has two blue DIP switch for setting operation mode. Please find out the switch from FIG-1. The method of setting is as follows:

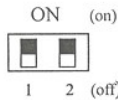

DIP Switch 1: Sensitivity Setting

ON (Default Setting) : high sensitivity mode

OFF: low sensitivity mode, set to this mode when under disturbance environment in order to avoid false alarm.

DIP Switch 2: Detector ON/OFF Switch

ON (Default Setting): normal operation mode

OFF : detector is switched off and has no working

Installation

COVERAGE ADJUSTMENT

Using the standard lens at the recommended installation height of 2.1m (7 ft) ±10%, the 406 will provide full coverage from 1.2m (4 ft) to 9m (29 ft), without any dead zones. Please ensure that the PCB is fixed at the 2.1m (7 ft) mark. (A small vertical adjustment of the PCB (± 0.5mm) may be required.). Please see FIG-2.

Avoid placing the detector in proximity to the following sources of interferences: reflective surfaces, direct air flow, sources of steam/oil vapor, infrared light sources, and objects causing temperature changes such as heaters, refrigerators and ovens, and infrared light sources. After selecting the detector's location, drill holes for the screws as per fig-1 and Fig-3.

Corner mount: Carefully remove the PCB(9) by loosening PCB screw(8) and utilize holes A、B、C and D.

Flat surface mount: Carefully remove the PCB(9) by loosening PCB screw(8) and utilize holes E、F、G and H.

Wiring: Run the wires through entry hole I and J, and connect them according to the marking on the plastic back and as per FIG-4.

Turn On the Detector

Self-testing program:

Turning on the detector initiates a self-testing program for the signal processor, memory and relay. A flashing light for 60 seconds will indicate that the system is fully operational.

Digital Signal Processing

Movement Analysis: Movement generates a unique sequence of signals. For each signal, Digital Shield software measures and calculates the signal's parameters (amplitude, duration, peak level, polarity, rise time and shape) in real time and then stores them in memory. Each signal is compared with a reference bank of movement and non-movement signals. If the signal does not meet movement criteria, it is immediately rejected.

Auto Pulse Signal Processing (APSP) measures energy from each detected signal and stores it in memory. To generate an alarm, the memory must reach a required minimum level. Thus, in the presence of high-level signals (very low risk of false alarms) the detector immediately generates an alarm, functioning as a "non-pulse count" detector, while low level signals (presenting a high risk of false alarms) will cause the detector to automatically switch to a very high pulse count mode - resulting in excellent protection against false alarms. Pulse counting rate depends on signal energy levels and can go much higher for RFI signals.

Due to the complicated software computing procedure, sometimes the alarm will be delayed for 0.25-1 second after actual movement.

FIG-1
EXPLODED VIEW

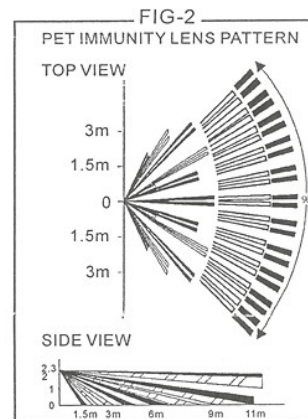
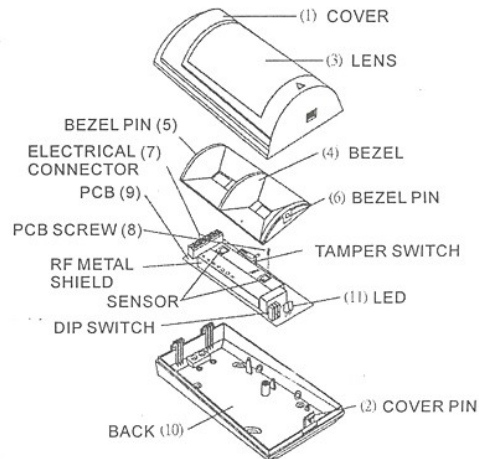
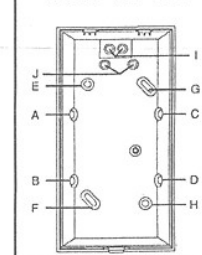

FIG-3
BACK - TOP VIEW



SAMTEK

Pet Immunity

The 406 has two dual element sensors for 3-D space detection. In addition it combines with the proprietary Pet-friendly lens greatly decrease false alarms created by pets. In order to generate an alarm, an object must cross the beams created by both the lower and upper sensor (see FIG-2). Due to the small height and volume of a pet, they will not generate the required signal value normally recognized as an alarm situation. Any PCB adjustments should be followed by a walk-test of the protected area. Walk-testing verifies that the required coverage is in place.

Walk Testing

At 20°C in high sensitivity mode, you should not be able to cross more than one complete zone (consisting of two beams – left and right sensor detecting elements) in the coverage area with any kind of movement – running, fast or slow walking. In low sensitivity mode, the amount of movement required to generate an alarm is doubled. The approximate width of a full beam at 9m (30 ft) from the detector is 1.5m (4.9 ft). Please see FIG-2.

Note: Do not walk facing and towards to a PIR motion detector because the detector can not detect this movement direction. Your movement direction should be vertical to the beam of detector.

Alarm Memory

Using the programmable output of the control panel to generate -12V to the terminal "MEM" of 406 upon arming will trigger the alarm memory function of 406. If the detector is alarmed during armed period, the alarm signal will be memorized and the LED will lights for 5 minutes when the panel is disarmed(delete "-12V").

Important Notes

Upon completion of installation, all openings in the detector should be sealed with silicone to prevent drafts or insects from entering the detector. Please keep the lens clean in order to achieve good effect. Burglar alarm systems should be check once a week.

Warranty

The Seller warrants its products to be free from defects in materials and workmanship under normal use for a period of one year. Except as specifically stated herein, all express or implied warranties whatsoever, statutory or otherwise, including without limitation, any implied warranty of merchantability and fitness for a particular purpose, are expressly excluded. Since Seller does not install or connect the products and because the products may be used in conjunction with products not manufactured by Seller. Seller cannot guarantee the performance of the security system. Seller obligation and liability under this warranty is expressly limited to repairing or replacing, at Seller's option, any product not meeting the specifications. In no event shall the Seller be liable to the buyer or any other person for any loss or damages whether direct or indirect or consequential or incidental, including without limitation, any damages for lost profits stolen goods, or claims by any other party, caused by defective goods or otherwise arising from the improper, incorrect or otherwise faulty installation or use of the merchandise sold.

Specification

Sensor	
Sensor Quantity	2
Type	Dual element
PIR Geometry	Rectangular
Digital Signal Processor	
Energy Analyses	Energy, peak, duration, width & shape
Digital Auto Pulse Processing	2 levels adjustable
Digital SHIELD software	Yes
Digital Temperature Compensation	Yes
A/D Type	Converts directly, 1 bit linear
Resolution	10 bit
Sampling	15.6KHz
Additional Sampling	256X
S / N Ratio	60dB
Dynamic Range	60dB
Frequency Response	0.2 Hz to 7Hz ± 3dB
Digital Signal Processing Sampling	61 Hz
Characteristics	
Detection Speed	0.1 ~ 5 m / second
Detect Animal Weight	Over 40kg
Operating Temperature	-20°C ~ +60°C
Power Source	8-15Vdc, max. 17mA
RFI/EMI Rejection	60-70 V/M
Lens	Second generation LODIFF Fresnel lens
Coverage Range	Min. 9 meters x 90°
Zones	22 = 9+5+5+3
Mounting Height	2 ~ 2.7m
Alarm Indication	Red LED lights 2 seconds
Alarm Output	Normal closed, 28Vdc / 0.15A (optional normal open)
Anti Tamper Switch	Normal close output, opens when cover removed, 0.15A, 28Vdc
Alarm Memory	LED light up for 5 minute upon disarm
Humidity	Max. 95%
Weight	90g

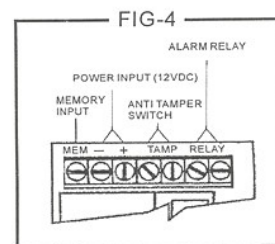

SAMTEK