

YASKAWA AC Drive 1000-Series Option Complementary Type PG Installation Manual

Type: PG-B3

To properly use the product, read this manual thoroughly and retain for easy reference, inspection, and maintenance. Ensure the end user receives this manual.

安川インバータ 1000シリーズ オプション コンプリメンタリタイプ PG 取扱説明書

形 式 PG-B3

製品を安全にお使い頂くために、この取扱説明書を必ずお読みください。
また、本書をお手元に保管していただくとともに、最終的に本製品をご使用になるユーザー様のお手元に確実に届けられるよう、お取り計らい願います。

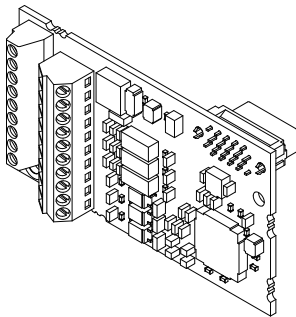

Copyright © 2008 YASKAWA ELECTRIC CORPORATION

All rights reserved. No part of this publication may be reproduced, stored in a retrieval system, or transmitted, in any form or by any means, mechanical, electronic, photocopying, recording, or otherwise, without the prior written permission of Yaskawa. No patent liability is assumed with respect to the use of the information contained herein. Moreover, because Yaskawa is constantly striving to improve its high-quality products, the information contained in this manual is subject to change without notice. Every precaution has been taken in the preparation of this manual. Yaskawa assumes no responsibility for errors or omissions. Neither is any liability assumed for damages resulting from the use of the information contained in this publication.



Table of Contents

| | |
|---------------------------------------|-----------|
| 1 Preface and Safety | 4 |
| 2 Product Overview | 8 |
| 3 Receiving | 9 |
| 4 Option Components | 10 |
| 5 Installation Procedure | 11 |
| 6 Related Parameters | 26 |
| 7 Troubleshooting | 29 |
| 8 Specifications | 34 |

1 Preface and Safety

Yaskawa manufactures products used as components in a wide variety of industrial systems and equipment. The selection and application of Yaskawa products remain the responsibility of the equipment manufacturer or end user. Yaskawa accepts no responsibility for the way its products are incorporated into the final system design. Under no circumstances should any Yaskawa product be incorporated into any product or design as the exclusive or sole safety control. Without exception, all controls should be designed to detect faults dynamically and fail safely under all circumstances. All systems or equipment designed to incorporate a product manufactured by Yaskawa must be supplied to the end user with appropriate warnings and instructions as to the safe use and operation of that part. Any warnings provided by Yaskawa must be promptly provided to the end user. Yaskawa offers an express warranty only as to the quality of its products in conforming to standards and specifications published in the Yaskawa manual. **NO OTHER WARRANTY, EXPRESS OR IMPLIED, IS OFFERED.** Yaskawa assumes no liability for any personal injury, property damage, losses, or claims arising from misapplication of its products.

◆ Applicable Documentation

The following manuals are available for the option:

Option

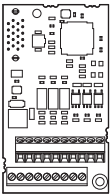
| | | |
|---|--|---|
|  | Yaskawa AC Drive 1000-Series Option PG-B3 Installation Manual (This book) Manual No: TOBPC73060036 | Read this manual first. The installation manual is packaged with the option and contains information required to install the option and set up related drive parameters. |
|---|--|---|

Yaskawa Drive

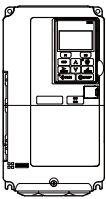
| | | |
|--|---|---|
|  | Yaskawa AC Drive 1000-Series Quick Start Guide | The drive manuals cover basic installation, wiring, operation procedures, functions, troubleshooting, and maintenance information. |
| | Yaskawa AC Drive 1000-Series Technical Manual | The manuals also include important information about parameter settings and drive tuning. Access these sites to obtain Yaskawa instruction manuals: U.S.: http://www.yaskawa.com Europe: http://www.yaskawa.eu.com Japan: http://www.e-mechatronics.com For questions, contact your local Yaskawa sales office or the nearest Yaskawa representative. |

◆ Terms and Abbreviations

| | |
|------------------|---|
| Note: | Indicates supplemental information that is not related to safety messages |
| Drive: | Yaskawa AC Drive 1000-Series |
| Option: | Yaskawa AC Drive 1000-Series Option Motor PG Feedback Complementary: Type PG-B3 |
| PG: | Pulse Generator or Encoder mounted on the motor |
| V/f: | V/f Control |
| V/f w/PG: | V/f Control with PG |
| CLV: | Closed Loop Vector Control |
| AOLV/PM: | Advanced Open Loop Vector Control for PM |
| CLV/PM: | Closed Loop Vector Control for PM |

◆ Registered Trademarks

Trademarks are the property of their respective owners.

◆ Supplemental Safety Information

Read and understand this manual before installing, operating, or servicing this option. Install the option according to this manual and local codes.

The following conventions indicate safety messages in this manual. Failure to heed these messages could cause fatal injury or damage products and related equipment and systems.

DANGER

Indicates a hazardous situation, which, if not avoided, will result in death or serious injury.

WARNING

Indicates a hazardous situation, which, if not avoided, could result in death or serious injury.

1 Preface and Safety

CAUTION

Indicates a hazardous situation, which, if not avoided, could result in minor or moderate injury.

NOTICE

Indicates an equipment damage message.

■ General Safety

General Precautions

- The diagrams in this book may include options and drives without covers or safety shields to illustrate details. Be sure to reinstall covers or shields before operating any devices. Use the option according to the instructions described in this manual.
- Any illustrations, photographs, or examples used in this manual are provided as examples only and may not apply to all products to which this manual is applicable.
- The products and specifications described in this manual or the content and presentation of the manual may be changed without notice to improve the product and/or the manual.
- When ordering new copies of the manual, contact a Yaskawa representative or the nearest Yaskawa sales office and provide the manual number shown on the front cover.

DANGER

Heed the safety messages in this manual.

Failure to comply will result in death or serious injury.

The operating company is responsible for any injuries or equipment damage resulting from failure to heed the warnings in this manual.

NOTICE

Do not modify the drive or option circuitry.

Failure to comply could result in damage to the drive or option and will void warranty. Yaskawa is not responsible for any modification of the product made by the user. This product must not be modified.

Do not expose the drive or option to halogen group disinfectants.

Failure to comply may cause damage to the electrical components in the option.
Do not pack the drive in wooden materials that have been fumigated or sterilized.
Do not sterilize the entire package after the product is packed.

2 Product Overview

◆ About This Product

The PG-B3 Option allows the user to connect an incremental encoder with complementary output (PG) for motor speed feedback to the drive and take advantage of the V/f with PG, Closed Loop Vector, and Closed Loop Vector for PM motors control modes. The option helps increase the control accuracy and higher performance.

This PG encoder signal allows the drive to compensate for subtle variations in the load, while providing the drive with the necessary data to control the output frequency and maintain an accurate constant speed.

The PG-B3 Option reads a maximum input frequency from the PG encoder of 50 kHz. Be sure to select an PG encoder with an output of maximum 50 kHz when operating at maximum speed.

◆ Applicable Models

The option can be used with the drive models in [Table 1](#).

Table 1 Applicable Models



| Drive Series | Drive Model Number |
|--------------|--------------------|
| A1000 | All models |
| L1000A | All models |

3 Receiving

Please perform the following tasks upon receiving the option:

- Inspect the option for damage. Contact the shipper immediately if the option appears damaged upon receipt.
- Verify receipt of the correct model by checking the model number printed on the option nameplate (Refer to **Figure 1** on page **10** for more information).
- Contact your supplier if you have received the wrong model or the option does not function properly.

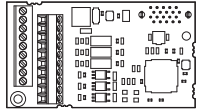
◆ Option Package Contents

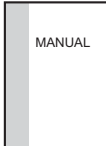
| Description: | Option | Ground Wires | Screws (M3) | Installation Manual |
|--------------|---|---|---|---|
| — |  |  |  |  |
| Quantity: | 1 | 2 | 3 | 1 |

◆ Tools Required for Installation

- A Phillips screwdriver (M3 metric / #1, #2 U.S. standard size) is required to install the option.
- A straight-edge screwdriver (blade depth: 0.4 mm, width: 2.5 mm) is required to wire the option terminal block.
- A pair of diagonal cutting pliers.
- A small file or medium-grit sandpaper.

Note: Tools required to prepare option cables for wiring are not listed in this manual.

4 Option Components

◆ PG-B3 Option

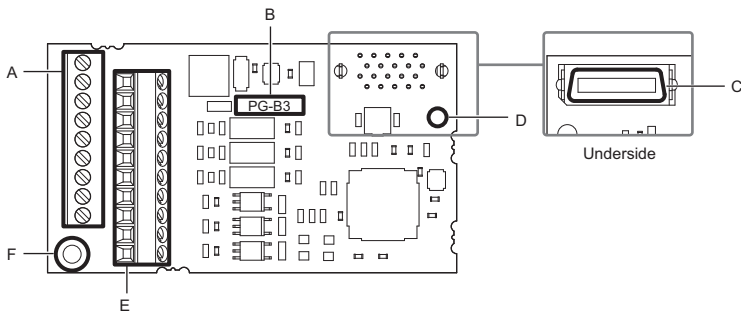

A – Terminal block TB1

B – Model number

C – Connector (CN5)

D – Installation hole

E – Terminal block TB2

F – Ground terminal and installation hole <1>

<1> The ground wires provided in the option shipping package must be connected during installation.

Figure 1 PG-B3 Option Components

◆ Terminal Blocks TB1 and TB2

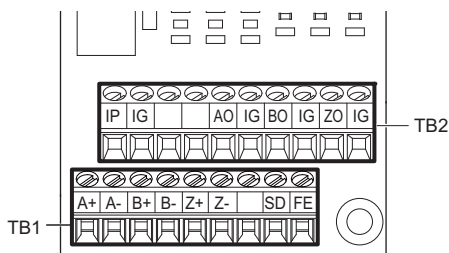

Refer to [Table 6](#) on page [25](#) for details on TB1 and TB2 terminal functions and signal levels.

5 Installation Procedure

◆ Section Safety

DANGER

Electric Shock Hazard

Do not connect or disconnect wiring while the power is on.

Failure to comply will result in death or serious injury.

Disconnect all power to the drive, wait at least the amount of time specified on the drive front cover safety label. After all indicators are off, measure the DC bus voltage to confirm safe level, and check for unsafe voltages before servicing. The internal capacitor remains charged after the power supply is turned off.

WARNING

Electrical Shock Hazard

Do not remove the front covers of the drive while the power is on.

Failure to comply could result in death or serious injury.

The diagrams in this section may include options and drives without covers or safety shields to show details. Be sure to reinstall covers or shields before operating any devices. Use the option according to the instructions described in this manual.

Do not allow unqualified personnel to use equipment.

Failure to comply could result in death or serious injury.

Maintenance, inspection, and replacement of parts must be performed only by authorized personnel familiar with installation, adjustment, and maintenance of this product.

Do not touch circuit boards while the power to the drive is on.

Failure to comply could result in death or serious injury.

5 Installation Procedure

WARNING

Do not use damaged wires, stress the wiring, or damage the wire insulation.

Failure to comply could result in death or serious injury.

Fire Hazard

Tighten all terminal screws to the specified tightening torque.

Loose electrical connections could result in death or serious injury by fire due to overheating of electrical connections.

NOTICE

Damage to Equipment

Observe proper electrostatic discharge (ESD) procedures when handling the option, drive, and circuit boards.

Failure to comply may result in ESD damage to circuitry.

Never shut the power off while the drive is running or outputting voltage.

Failure to comply may cause the application to operate incorrectly or damage the drive.

Do not operate damaged equipment.

Failure to comply may cause further damage to the equipment.

Do not connect or operate any equipment with visible damage or missing parts.

Do not use unshielded cable for control wiring.

Failure to comply may cause electrical interference resulting in poor system performance.

Use shielded twisted-pair wires and ground the shield to the ground terminal of the drive.

Properly connect all pins and connectors.

Failure to comply may prevent proper operation and possibly damage equipment.

Check wiring to ensure that all connections are correct after installing the option and connecting any other devices.

Failure to comply may result in damage to the option.

◆ Prior to Installing the Option

Prior to installing the option, wire the drive, make the necessary connections to the drive terminals, and verify that the drive functions normally. Refer to the Quick Start Guide packaged with the drive for information on wiring and connecting the drive.

Figure 2 shows an exploded view of the drive with the option and related components for reference.

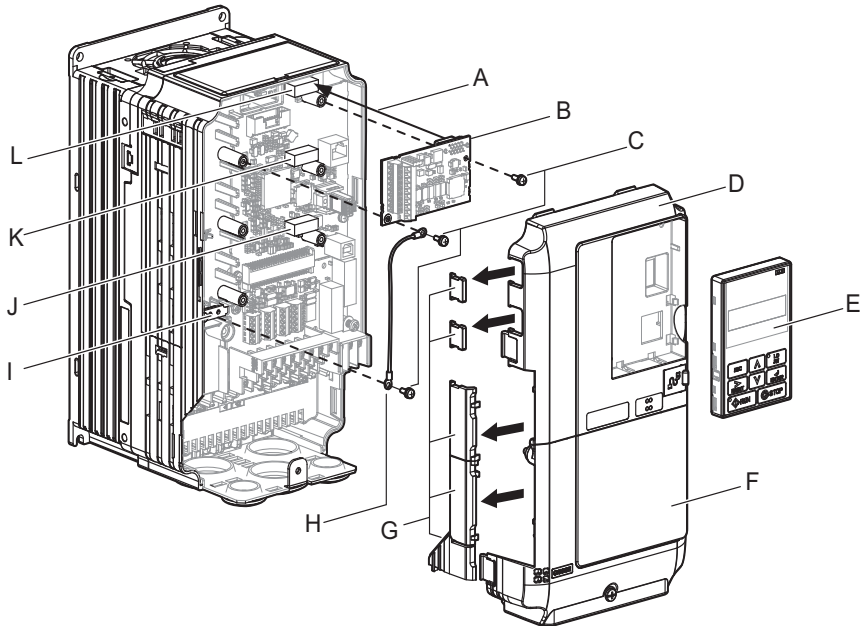

- | | |
|------------------------------------|--|
| A – Insertion point for CN5 | G – Removable tabs for wire routing |
| B – Option card | H – Ground wire |
| C – Included screws | I – Drive grounding terminal (FE) |
| D – Front cover | J – Connector CN5-A |
| E – Digital operator | K – Connector CN5-B |
| F – Terminal cover | L – Connector CN5-C |

Figure 2 Drive Components with Option

5 Installation Procedure

◆ Installing the Option

Refer to the instructions below to install the option.

1. Shut off power to the drive, wait the appropriate amount of time for voltage to dissipate, then remove the digital operator (E) and front covers (D, F). Refer to the Quick Start Guide packaged with the drive.

DANGER! *Electrical Shock Hazard. Disconnect all power to the drive and wait at least the amount of time specified on the drive front cover safety label. After all indicators are off, measure the DC bus voltage to confirm safe level, and check for unsafe voltages before servicing to prevent electric shock. The internal capacitor remains charged even after the power supply is turned off.*

NOTICE: *Damage to Equipment. Observe proper electrostatic discharge procedures (ESD) when handling the option, drive, and circuit boards. Failure to comply may result in ESD damage to circuitry.*

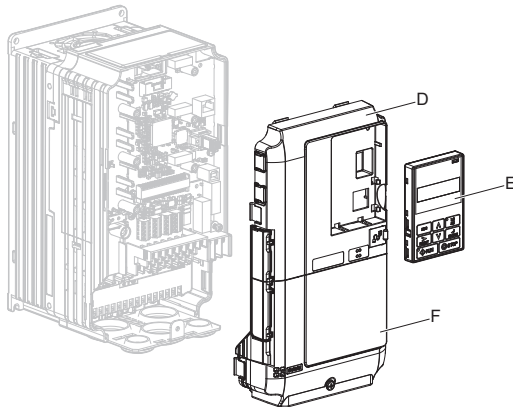

Figure 3 Remove the Front Covers and Digital Operator

2. Insert the option card (B) into the CN5-B (K) or CN5-C (L) connectors located on the drive and fasten it into place using one of the included screws (C). Use the CN5-C connector (L) when connecting only one option to the drive; use both CN5-B and CN5-C when connecting two options.

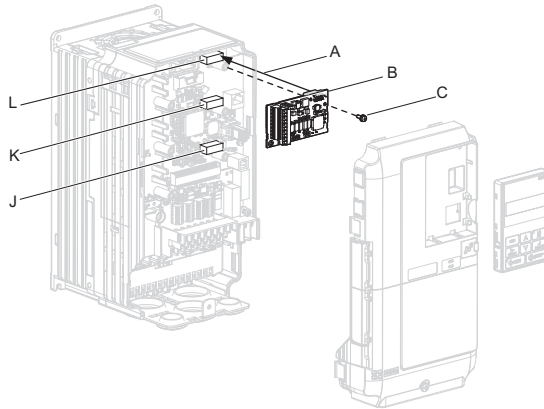

Figure 4 Insert the Option Card

5 Installation Procedure

3. Connect one end of the ground wire (H) to the ground terminal (I) using one of the remaining screws (C). Connect the other end of the ground wire (H) to the remaining ground terminal and installation hole on the option (B) using the last remaining provided screw (C).

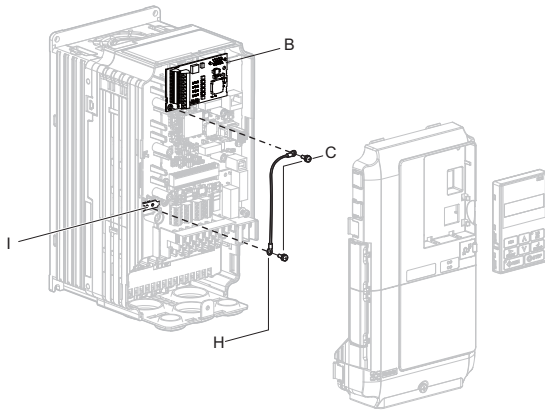

Figure 5 Connect the Ground Wire

- Note:**
1. The option package includes two ground wires. Use the longer wire when plugging the option into connector CN5-C on the drive side. Use the shorter wire when plugging the option into connector CN5-B. *Refer to Option Package Contents on page 9* for more information.
 2. There are two screw holes on the drive for use as ground terminals (I). When connecting three options, two ground wires will need to share the same drive ground terminal.

- Prepare and connect the wire ends as shown in [Figure 6](#) and [Figure 7](#). Refer to [Wire Gauges and Tightening Torques on page 24](#) to confirm that the proper tightening torque is applied to each terminal. Take particular precaution to ensure that each wire is properly connected and wire insulation is not accidentally pinched into electrical terminals.

WARNING! Fire Hazard. Tighten all terminal screws according to the specified tightening torque. Loose electrical connections could result in death or serious injury by fire due to overheating electrical connections. Tightening screws beyond the specified tightening torque may result in erroneous operation, damage the terminal block, or cause a fire.

NOTICE: Heat shrink tubing or electrical tape may be required to ensure that cable shielding does not contact other wiring. Insufficient insulation may cause a short circuit and damage the option or drive.

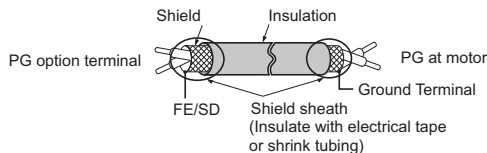

Figure 6 Preparing Ends of Shielded Cable

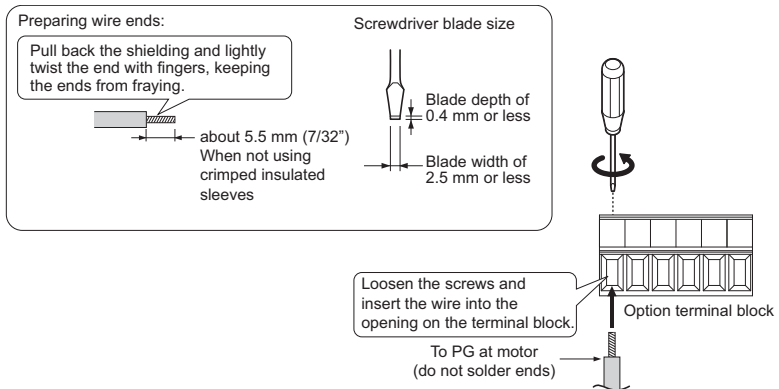

Figure 7 Preparing and Connecting Cable Wiring

- Wire the motor PG encoder to the terminal block on the option. Refer to [Figure 8](#) and [Figure 9](#) for wiring instructions. Refer to [Option Terminal Functions on page 25](#) for a detailed description of the option terminal functions.

5 Installation Procedure

■ Parameter Settings and Connections for Different Encoder Types

Connecting a Single-Pulse Encoder

When using a single-pulse encoder in V/f with PG control mode, connect the pulse output from the PG to the option and set drive parameter F1-21 to 0.

Connecting a Two-Pulse Encoder

When using a two-pulse encoder, connect the A and B pulse outputs on the PG to the option and set F1-21 to 1.

When using a two-pulse encoder in Closed Loop Vector control mode, connect pulse outputs A and B from the encoder to the corresponding terminals on the option.

Connecting a Two-Pulse Encoder with Z Marker Pulse

When using a two-pulse encoder with Z marker pulse, connect the A, B, and Z pulse outputs to the corresponding terminals on the option.

| Control Method | V/f with PG | | Closed Loop Vector | |
|-----------------------------|-------------|-----------|---------------------|---------------------|
| | 1 (CN5-C) | 2 (CN5-B) | 1 (CN5-C) | 2 (CN5-B) |
| No. of Encoders | 1 (CN5-C) | 2 (CN5-B) | 1 (CN5-C) | 2 (CN5-B) |
| Single Pulse (A) | F1-21 = 0 | F1-37 = 0 | N/A | N/A |
| Two Pulse (AB Quadrature) | F1-21 = 1 | F1-37 = 1 | No setting required | No setting required |
| Two Pulse with Marker (ABZ) | F1-21 = 1 | F1-37 = 1 | No setting required | No setting required |

Connection Diagram

Refer to [Table 6](#) on page [25](#) for a detailed description of the option board terminal functions.

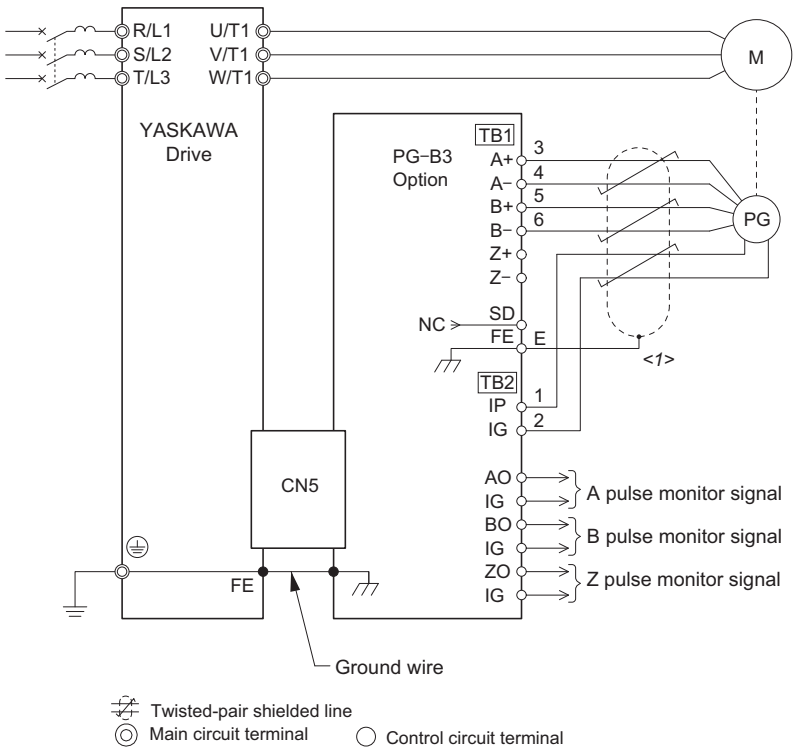

<1> Ground the shield on the PG side and the drive side. If noise problems arise in the PG signal, remove the shield ground from one end of the signal line or remove the shield ground connection on both ends.

Figure 8 PG-B3 Option and Encoder Connection Diagram

5 Installation Procedure

PG Encoder Cables

Yaskawa recommends using a LMA-□□B-S185Y (complementary output) for cables running between the option and the PG as show in *Figure 9*.

For instructions on wiring the terminal block, refer to *Terminal Functions on page 25*.

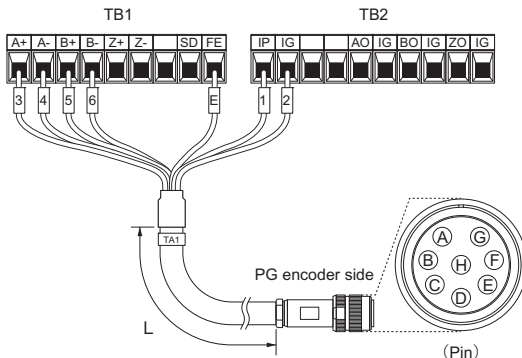

Figure 9 Wiring PG Encoder Cable

Table 2 Connecting the PG Encoder Cable Specification

| Option Terminal | PG Encoder Cable | | |
|-----------------|------------------|--------------|-----|
| | Wire | Color | Pin |
| IP | 1 | Blue | C |
| IG | 2 | White | H |
| A+ | 3 | Yellow | B |
| A- | 4 | White | G |
| B+ | 5 | Green | A |
| B- | 6 | White | F |
| FE | E | N/A (shield) | D |

Table 3 PG Encoder Cable Types

| Length | Type | Length | Type |
|---------------|-------|-----------------|-------|
| 10 m (32 ft.) | W5010 | 50 m (164 ft.) | W5050 |
| 30 m (98 ft.) | W5030 | 100 m (328 ft.) | W5100 |

- 6.** Route the option wiring.
Depending on the drive model, some drives may require routing the wiring through the side of the front cover to the outside. In these cases, cut out the perforated openings on the left side of the drive front cover as shown in **Figure 10-A** and leave no sharp edges to damage wiring.
Route the wiring inside the enclosure as shown in **Figure 10-B** for drives that do not require routing through the front cover.
Refer to the *Peripheral Devices & Options* section of the drive Technical Manual for more information.

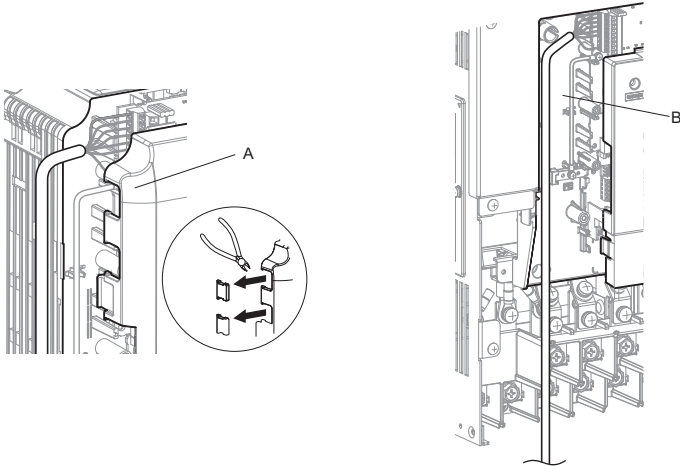

A – Route wires through the openings provided on the left side of the front cover. <1>

B – Use the open space provided inside the drive to route option wiring.

<1> The drive will not meet NEMA Type 1 requirements if wiring is exposed outside the enclosure.

Figure 10 Wire Routing Examples

5 Installation Procedure

7. Replace and secure the front covers of the drive (D, F) and replace the digital operator (E).

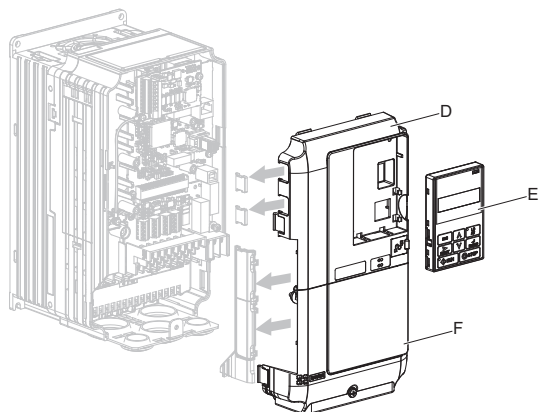

Figure 11 Replace the Front Covers and Digital Operator

Note: Take proper precautions when wiring the option so that the front covers will easily fit back onto the drive. Make sure cables are not pinched between the front covers and the drive when replacing the covers.

8. Set drive parameters in [Table 7](#) for proper motor rotation.

With a two-pulse or three-pulse PG encoder, the leading pulse determines the motor rotation direction. A PG encoder signal with leading A pulse is considered to be rotating forward (counter-clockwise when viewing rotation from motor load side).

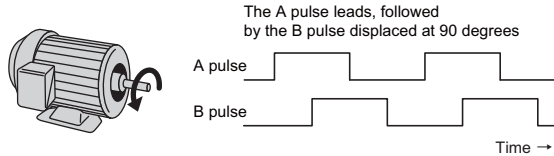

Figure 12 Displacement of A and B Pulses

After connecting the PG encoder outputs to the option, apply power to the drive and manually rotate the motor and check the rotation direction by viewing monitor U1-05 on the digital operator.

Reverse motor rotation is indicated by a negative value for U1-05; forward motor rotation is indicated by a positive value.

If monitor U1-05 indicates that the forward direction is opposite of what is intended, reverse the two A pulse wires with the two B pulse wires on option terminal TB1 as shown in [Figure 13](#).

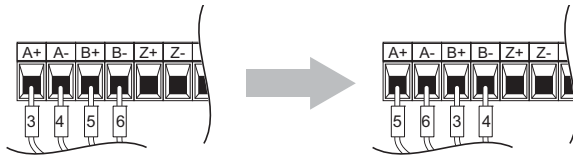

Figure 13 A Channel and B Channel Wire Switching

If switching the wires is inconvenient, set drive parameter F1-05/F1-32 to 1 to switch the direction of how the option reads pulses from the PG encoder output.

Please note that when the drive is initialized using A1-03 = 1110, 2220, 3330, the value for F1-05/F1-32 will reset to factory default and the parameter will need to be adjusted again to switch the direction.

5 Installation Procedure

◆ Wire Gauges, Tightening Torque, and Crimp Terminals

■ Wire Gauges and Tightening Torques

Wire gauge and torque specifications are listed in [Table 4](#).

Table 4 Wire Gauges and Tightening Torques

| Terminal Signal | Screw Size | Tightening Torque N·m (in·lb) | Bare Cable | | Crimp Terminals | | Wire Type |
|------------------------------------|------------|-------------------------------|---|-------------------------------|-----------------------------------|-------------------------------|-----------------------------|
| | | | Applicable Gauges mm ² | Recomm. Gauge mm ² | Applicable Gauges mm ² | Recomm. Gauge mm ² | |
| A+, A-, B+, B-, Z+, Z-, FE, IP, IG | M2 | 0.22 to 0.25 (1.95 to 2.21) | Stranded wire: 0.25 to 1.0 (24 to 17 AWG) | 0.75 (18 AWG) | 0.25 to 0.5 (24 to 20 AWG) | 0.5 (20 AWG) | Shielded twisted pair, etc. |
| AO, IG, BO, IG, ZO, IG | | | Solid wire: 0.25 to 1.5 (24 to 16 AWG) | | | | Shielded cable, etc. |

■ Crimp Terminals

Yaskawa recommends using CRIMPFOX 6 by Phoenix Contact or equivalent crimp terminals with the specifications listed in [Table 5](#) for wiring to ensure proper connections.

Note: Properly trim wire ends so loose wire ends do not extend from the crimp terminals.

Table 5 Crimp Terminal Sizes

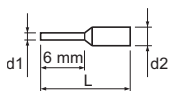
| | Wire Gauge mm ² | Phoenix Contact Model | L mm (in) | d1 mm (in) | d2 mm (in) |
|--|----------------------------|-----------------------|--------------|------------|------------|
|  | 0.25 (24 AWG) | AI 0.25 - 6YE | 10.5 (13/32) | 0.8 (1/32) | 2 (5/64) |
| | 0.34 (22 AWG) | AI 0.34 - 6TQ | 10.5 (13/32) | 0.8 (1/32) | 2 (5/64) |
| | 0.5 (20 AWG) | AI 0.5 - 6WH | 14 (9/16) | 1.1 (3/64) | 2.5 (3/32) |

◆ Terminal Functions

Table 6 Option Terminal Functions

| Terminal Block | Terminal | Function | Description |
|----------------|----------|------------------------|---|
| TB1 | A+ | A+ pulse signal input | <ul style="list-style-type: none"> • Pulse signal inputs from the PG. • Signal inputs from complementary and open-collector outputs • Signal level H level: 8 to 12 V L level: 2.0 V or less |
| | A- | A- inverse pulse input | |
| | B+ | B+ pulse signal input | |
| | B- | B- inverse pulse input | |
| | Z+ | Z+ pulse signal input | |
| | Z- | Z- inverse pulse input | |
| | SD | NC pin (open) | For use when cables shields should not be grounded |
| | FE | Ground | Used for grounding shielded lines |
| TB2 | IP | PG power supply | <ul style="list-style-type: none"> • Output voltage: 12.0 V \pm 5% • Max output current: 200 mA <I> |
| | IG | PG power supply common | |
| | AO | A pulse monitor signal | <ul style="list-style-type: none"> • Outputs the monitor signal for the A, B, and Z pulses from the PG speed control card • For open collector outputs from the option • Max voltage: 24 V • Max current: 30 mA |
| | BO | B pulse monitor signal | |
| | ZO | Z pulse monitor signal | |
| | IG | Monitor signal common | |

<I> A separate UL-listed class 2 power supply is necessary when the PG requires more than 200 mA to operate.

6 Related Parameters

The following parameters set the drive for operation with the option. Set parameters as needed. Parameter setting methods can be found in the drive Quick Start Guide or Technical Manual.

Table 7 Related Parameters

| No. (Addr. Hex) | Name | Description | Control Mode | Values |
|---------------------------|--------------------------------------|---|---------------------------------------|--------------------------------------|
| A1-02 (102) | Control Method Selection | 0: V/f Control 1: V/f Control with PG 2: Open Loop Vector Control 3: Closed Loop Vector Control 5: Open Loop Vector Control for PM 6: Advanced Open Loop Vector Control for PM 7: Closed Loop Vector Control for PM | All Modes | Default: </> Range: </> |
| F1-01 (380) </> </> | PG 1 Pulses per Revolution | Sets the pulses to be read from the pulse generator. | V/f w/ PG CLV CLV/PM | Default: </> Min: </> Max: </> |
| F1-02 (381) | PG Feedback Loss Operation Selection | Sets the stopping method after PG disconnect (PGo). 0: Ramp to stop (decelerates at time set to C1-02) 1: Coast to stop 2: Fast Stop (decelerates at the time set to C1-09) 3: Continue running 4: No alarm display NOTICE: Due to potential damage to the motor and machinery, only use settings 3 and 4 under special circumstances. | V/f w/ PG CLV CLV/PM | Default: 1 Range: </> |
| F1-03 (382) | PG Overspeed Operation Selection | Sets the stopping method after detecting overspeed. 0: Ramp to stop (decelerates at time set to C1-02) 1: Coast to stop 2: Fast Stop (decelerates at the time set to C1-09) 3: Continue running NOTICE: Due to potential damage to the motor and machinery, do not use the "Continue running" setting except under special circumstances. | V/f w/ PG CLV CLV/PM | Default: 1 Range: 0 to 3 |
| F1-04 (383) | PG Deviation Operation Selection | 0: Ramp to stop (decelerates at time set to C1-02) 1: Coast to stop 2: Fast Stop (decelerates at the time set to C1-09) 3: Continue running NOTICE: Due to potential damage to the motor and machinery, do not use the "Continue running" setting except under special circumstances. | V/f w/ PG CLV CLV/PM AOLV/PM | Default: </> Range: 0 to 3 |
| F1-05 (384) </> | PG 1 Rotation | 0: Forward = A pulse leads 1: Forward = B pulse leads | V/f w/ PG CLV CLV/PM | Default: </> Range: 0, 1 |

6 Related Parameters

| No. (Addr. Hex) | Name | Description | Control Mode | Values |
|-------------------------|--------------------------------------|---|---------------------------------------|---------------------------------------|
| F1-06 (385) <> | PG 1 Ratio for PG Pulse Monitor | Sets the division ratio for PG encoder pulse output. Set as a three-digit number: x is the first digit, y is the second digit, and z is the third digit: $\text{Ratio} = \frac{(1 + x)}{yz}$ When only the A pulse is read, this ratio is disabled and pulses are set as 1/32 : 1. | V/f w/ PG CLV CLV/PM | Default: 1 Min: 1 Max: 132 |
| F1-08 (387) | PG Overspeed Level | Sets the level for detecting overspeed as a percentage of the maximum output frequency. | V/f w/ PG CLV CLV/PM AOLV/PM | Default: 115 Min: 0 Max: 120 |
| F1-09 (388) | Overspeed Det. Time | Sets the time required for the motor to exceed the level set in F1-08 to trigger a fault. | V/f w/ PG CLV CLV/PM AOLV/PM | Default: <> Min: 0.0 Max: 2.0 |
| F1-10 (389) | Excessive Speed Deviation Det. Level | Sets the degree of speed deviation to trigger a dEv fault. Set as a percentage of the maximum output frequency. | V/f w/ PG CLV CLV/PM AOLV/PM | Default: 10 Min: 0 Max: 50 |
| F1-11 (38A) | Excessive Speed Deviation Det. Time | Sets the time required a speed deviation situation to trigger a fault. | V/f w/ PG CLV CLV/PM AOLV/PM | Default: 0.5 Min: 0.0 Max: 10.0 |
| F1-12 (38B) <> <> | PG 1 Gear Teeth 1 | Number of gear teeth between the PG and motor. $\frac{\text{Pulses} \times 60}{\text{F1-01}} \times \frac{\text{F1-13 (load side)}}{\text{F1-12 (motor side)}}$ | V/f w/ PG | Default: 0 Min: 0 Max: 1000 |
| F1-13 (38C) <> <> | PG 1 Gear Teeth 2 | A gear ratio of 1 will be used if any of these parameters is set to 0. | | |
| F1-14 (38D) | PG Disconnect Det. Time | Sets the time in seconds for PG encoder disconnect to be detected. | V/f w/ PG CLV CLV/PM | Default: 2.0 Min: 0.0 Max: 10.0 |
| F1-18 (3AD) <> | Reverse Rotation Det. for PG 1 | 0: Disabled n: Number of times a dv3 situation must be detected to trigger a fault. | CLV/PM | Default: 10 Min: 0 Max: 10 |
| F1-19 (3AE) <> | Reverse Rotation Det. for PG 1 | 0: Disabled n: Number of times a dv4 situation must be detected to trigger a fault. | CLV/PM | Default: 128 Min: 0 Max: 5000 |
| F1-21 (3BC) <> | PG 1 Option Function | 0: A pulse detection 1: AB pulse detection | V/f w/ PG | Default: 0 Range: 0, 1 |
| F1-30 (3AA) <> | Motor 2 PG Connector | Selects the PG option connector for motor 2. 0: CN5-C 1: CN5-B | V/f w/ PG CLV | Default: 1 Range: 0, 1 |

6 Related Parameters

| No. (Addr. Hex) | Name | Description | Control Mode | Values |
|------------------------|---------------------------------------|---|------------------|---------------------------------------|
| F1-31 (3B0) <><> | PG 2 Pulse Setting | Sets the pulses to be read from the pulse generator. | V/f w/ PG CLV | Default: 1024 Min: 0 Max: 60000 |
| F1-32 (3B1) <> | PG 2 Rotation | 0: Forward = A pulse leads 1: Forward = B pulse leads | V/f w/ PG CLV | Default: 0 Range: 0, 1 |
| F1-33 (3B2) <><> | PG 2 Gear Teeth 1 | Number of gear teeth between the PG and motor. $\frac{\text{Pulses} \times 60}{\text{F1-31}} \times \frac{\text{F1-33 (load side)}}{\text{F1-34 (motor side)}}$ | V/f w/ PG | Default: 0 Min: 0 Max: 1000 |
| F1-34 (3B3) <><> | PG 2 Gear Teeth 2 | A gear ratio of 1 will be used if any of these parameters is set to 0. | | |
| F1-35 (3BE) <> | PG 2 Division Ratio for Pulse Monitor | Sets the division ratio for PG encoder pulse output. Set as a three-digit number where x is the first digit, y is the second digit, and z is the third digit: $\text{Ratio} = \frac{(1 + x)}{yz}$ When only the A pulse is read, this ratio is disabled and pulses are set as 1/32 : 1. | V/f w/ PG CLV | Default: 1 Min: 1 Max: 132 |
| F1-37 (3BD) <> | PG 2 Option Function | 0: A pulse detection 1: AB pulse detection | V/f w/ PG | Default: 0 Range: 0, 1 |

<1> Varies by drive models.

<2> The number of output pulses for the PG encoder can be calculated with the following formula:

$$f_{PG}(\text{Hz}) = \frac{\text{Motor speed at maximum frequency output (min}^{-1}\text{)}}{60} \times \text{PG rating (p/rev)}$$

<3> The parameter is available only for the drive connector CN5-C.

<4> Value changes according to the control mode selection in A1-02.

<5> Enabled only when using the V/f with PG control mode.

<6> Depending on the drive series, a second PG encoder (PG 2) may not be possible. Refer to the drive Technical Manual for the drive in your application.

<7> The parameter is available only for the drive connector CN5-B.

7 Troubleshooting

◆ Drive-Side Error Codes

Table 8 lists the various fault codes related to the option and pulse generator. Refer to the drive Technical Manual for further details on fault codes.



Check the following items first when an error code occurs on the drive:

- Are the cables connected properly and securely?
- Is the option properly installed to the drive?
- Did a momentary power loss occur?

Table 8 Fault Displays, Causes, and Possible Solutions

| Digital Operator Display | | Fault Name |
|--|-----|---|
| dEv | dEv | Speed Deviation (for Control Mode with PG) |
| | | The deviation between the speed reference and speed feedback is greater than the setting in F1-10 for longer than the time set to F1-11. |
| Cause | | Possible Solution |
| The load is too heavy. | | Reduce the load. |
| The acceleration and deceleration times are set too short. | | Increase the acceleration and deceleration times (C1-01 through C1-08). |
| The load is locked up. | | Check the machine. |
| Parameters are set inappropriately. | | Check the settings of parameters F1-10 and F1-11. |
| Motor brake is engaged. | | Ensure the motor brake releases properly. |
| Digital Operator Display | | Fault Name |
| $dU1$ | dv1 | Z Channel Pulse Fault Detection |
| | | The motor turned one full rotation while failing to detect the Z channel pulse. |
| Cause | | Possible Solution |
| The PG encoder is disconnected or is not wired properly, or the PG option or PG encoder are damaged. | | <ul style="list-style-type: none"> • Rewire the PG encoder and make sure all wiring including shielded wiring is properly connected. • If the problem continues after cycling power, replace the PG option or the PG encoder. |
| Digital Operator Display | | Fault Name |
| $dU2$ | dv2 | Z Channel Pulse Noise Fault Detection |
| | | The Z channel pulse is out of phase by more than 5 degrees for the number of times specified in parameter F1-17. |
| Cause | | Possible Solution |
| PG encoder cable noise interference. | | Separate the PG encoder cable wiring from the source of the noise (e.g., drive output wiring). |

7 Troubleshooting

| The PG encoder is disconnected or is not wired properly, or the PG option or PG encoder are damaged. | | <ul style="list-style-type: none"> Rewire the PG encoder and make sure all wiring including shielded wiring is properly connected. If the problem continues after cycling power, replace the PG option or the PG encoder. |
|--|-----|--|
| Digital Operator Display | | Fault Name |
|  | dv3 | Inversion Detection <ul style="list-style-type: none"> Torque reference and acceleration are in opposite directions. The speed reference and actual motor speed differ by over 30% for the number of pulses set to parameter F1-18. |
| Cause | | Possible Solution |
| The Z channel pulse offset is not set properly to E5-11. | | Set the value for $\Delta\theta$ to E5-11 as specified on the motor nameplate. Replacing the PG encoder or changing the application so the motor rotates in reverse requires readjustment of the Z channel pulse offset. |
| An external force on the load side caused the motor to move. | | <ul style="list-style-type: none"> Make sure the motor is rotating in the proper direction. Investigate problems on the load side causing motor rotation in the opposite direction. |
| Noise interference along the PG encoder cable is affecting the A channel or B channel. | | <ul style="list-style-type: none"> Rewire the PG encoder and make sure all wiring including shielded wiring is properly connected. If the problem continues after cycling power, replace the PG option or the PG encoder. |
| The PG encoder is disconnected or is not wired properly, or the PG option or PG encoder are damaged. | | |
| The PG encoder rotational direction set to F1-05 is in the opposite direction of the motor wiring. | | Make sure motor wiring for each phase (U, V, W) is connected properly. |
| Digital Operator Display | | Fault Name |
|  | dv4 | Inversion Prevention Detection <p>Pulses indicate that the motor is rotating in the opposite direction of the speed reference. Set the number of pulses to trigger inverse detection to F1-19.</p> <p>Note: To avoid nuisance faults, be sure to disable inverse detection in applications where the motor may rotate in the opposite direction of the speed reference. Set F1-19 to 0 to disable this feature.</p> |
| Cause | | Possible Solution |
| The Z channel pulse offset is not set properly to E5-11. | | <ul style="list-style-type: none"> Set the value for $\Delta\theta$ to E5-11 as specified on the motor nameplate. If the problem continues after cycling power, replace the PG option or the PG encoder. Replacing the PG encoder or changing the application so the motor rotates in reverse requires readjustment of the Z channel pulse offset. |
| Noise interference along the PG encoder cable is affecting the A or B pulse. | | <ul style="list-style-type: none"> Make sure the motor is rotating in the proper direction. Investigate problems on the load-side that may be causing the motor to rotate in the opposite direction. |

7 Troubleshooting

| PG encoder is disconnected or is not wired properly, or the PG option or PG encoder are damaged. | | <ul style="list-style-type: none"> • Rewire the PG encoder and make sure all wiring including shielded wiring is properly connected. • If the problem continues after cycling power, replace the PG option or the PG encoder. |
|---|-------|--|
| Digital Operator Display | | Fault Name |
| | oFA00 | Non-Compatible Option connected to drive port CN5-A |
| Cause | | Possible Solution |
| Non-compatible option connected to drive port CN5-A. | | Use only compatible options. Connect PG-B3 to CN5-B or CN5-C. For other option, refer to the Installation Manual for that option. |
| Digital Operator Display | | Fault Name |
| | oFb00 | Non-Compatible Option connected to drive port CN5-B |
| Cause | | Possible Solution |
| Non-compatible option connected to drive port CN5-B. | | Use only compatible options. For other option, refer to the Installation Manual for that option. |
| Digital Operator Display | | Fault Name |
| | oFb01 | Option Connection Error at drive port CN5-B |
| Cause | | Possible Solution |
| Option at drive port CN5-B was changed during run. | | Switch the power off and reconnect the option. |
| Digital Operator Display | | Fault Name |
| | oFC01 | Option Connection Error at drive port CN5-C |
| Cause | | Possible Solution |
| Option at drive port CN5-C was changed during run. | | Switch the power off and reconnect the option. |
| Digital Operator Display | | Fault Name |
| | oS | Overspeed |
| | | The motor speed feedback exceeded the F1-08 setting. |
| Cause | | Possible Solution |
| Overshoot is occurring. | | <ul style="list-style-type: none"> • Increase the settings for C5-01 (Speed Control Proportional Gain 1) and reduce C5-02 (Speed Control Integral Time 1). • Enable Feed Forward Control and perform Inertia Auto-Tuning in CLV. |
| Incorrect speed feedback scaling when terminal RP is used as speed feedback input in V/f control. | | <ul style="list-style-type: none"> • Set H6-02 to the value of the speed feedback signal frequency when the motor runs at the maximum speed. • Adjust the input signal using parameters H6-03 through H6-05. |
| Incorrect PG encoder pulse number set. | | Check and correct parameter F1-01. |
| Inappropriate parameter settings. | | Check the setting for the overspeed detection level and the overspeed detection time (F1-08 and F1-09). |

7 Troubleshooting

| Digital Operator Display | | Fault Name |
|--|-----|--|
| PGo | PGo | PG Encoder Disconnected |
| | | Detected when no PG encoder pulses received for a time longer than setting in F1-14. |
| Cause | | Possible Solution |
| PG encoder cable is disconnected. | | Reconnect the cable. |
| PG encoder cable wiring is wrong. | | Correct the wiring. |
| PG encoder does not have enough power. | | Make sure the correct power supply is properly connected to the PG encoder. |
| Brake is holding the PG encoder. | | Ensure the brake releases properly. |

Table 9 Operation Error Displays, Causes, and Possible Solutions

| Digital Operator Display | | Fault Name |
|---|-------|---|
| oPE06 | oPE06 | Control Method Selection Error |
| | | Correct the setting for the control method. |
| Cause | | Possible Solution |
| Control mode requires installing a PG option, but no PG option is installed (A1-02 = 1, 3, or 7). | | <ul style="list-style-type: none"> • Connect a PG option. • Correct the value set to A1-02. |

◆ Preventing Noise Interference

Take the following steps to prevent erroneous operation caused by noise interference:

- Use shielded wire for the PG encoder signal lines.
- Limit the length of all motor output power cables to less than 100 m. Limit the length of open-collector output lines to less than 50 m.
- Separate the control wiring to the option, main circuit input power wiring, and motor output power cables.
- Ground the shield on the PG encoder side and the drive side. If noise problems arise in the PG encoder signal, verify that the shield is properly grounded and ground one end of the signal line or remove the ground connection on both ends.

Interface Circuit Complementary Output

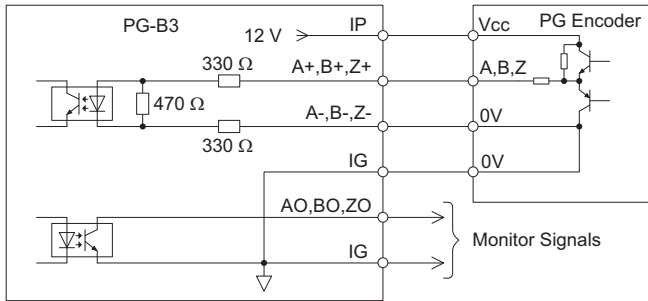

Figure 14 Complementary Outputs for the Interface Circuit

Open-Collector Outputs

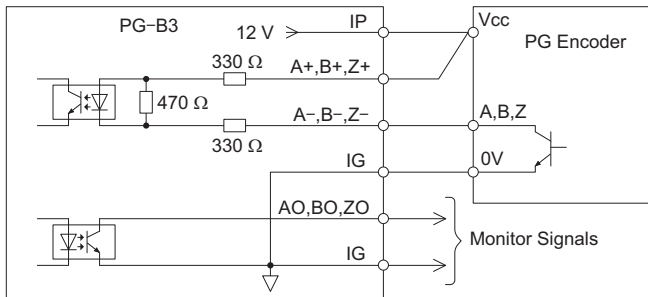

Figure 15 Open-Collector Outputs for the Interface Circuit

8 Specifications

Table 10 Option Specifications

| Items | Description |
|--|---|
| Model | PG-B3 |
| Compatible Pulse Generators | Complementary, Open-collector Single-pulse (A pulse), two-pulse (A, B pulse) or three-pulse (A, B, Z pulse) H level: 8 to 12 V L level: 2.0 V max. |
| PG Encoder Wiring Length | Complementary: 100 m (328 ft.) maximum Open-collector: 50 m (164 ft.) maximum |
| PG Encoder Power Supply | Output voltage: 12 V \pm 5% Max. Output Current: 200 mA |
| Compatible Control Modes | V/f with PG, Closed Loop Vector, Closed Loop Vector for PM motors |
| Maximum Input Frequency | 50 kHz |
| Pulse Monitor Output | Monitor for A, B, and Z pulse output: 24 V max, 30 mA Open-collector output |
| PG Encoder Disconnect Detection | Software detection |
| Ambient Temperature | -10°C to 50°C (14 °F to 122 °F) |
| Humidity | 95% RH or lower with no condensation |
| Storage Temperature | -20°C to 60°C (-4 °F to 140 °F) allowed for short-term transport of the product |
| Area of Use | Indoor (free of corrosive gas, airborne particles, etc.) |
| Altitude | 1000 m (3280 ft.) or lower |

◆ Revision History

Revision dates and manual numbers appear on the bottom of the back cover.

MANUAL NO. TOBP C730600 36A

Published in Japan April 2009 08-7 ①

└─ Revision number
 └─ Date of original publication
 └─ Date of publication

| Date of Publication | Rev. No | Section | Revised Content |
|---------------------|---------|----------------------------|---|
| December 2010 | ⑥ | – | Japanese version only. |
| November 2010 | ⑤ | Front cover, back cover | Revision: Format |
| | | Entire Document | Edited for procedural clarity and readability. |
| July 2010 | ④ | Back cover | Revision: Address |
| July 2010 | ③ | Entire Document | Edited for procedural clarity and readability. |
| | | Back cover | Revision: Address |
| April 2010 | ② | Back cover | Revision: Address |
| April 2009 | ① | Chapter 4 | Addition: ◆ Connection Diagram Instruction to counteract noise by grounding shielded lines |
| July 2008 | – | – | First edition |

YASKAWA AC Drive 1000-Series Option Complementary Type PG Installation Manual

DRIVE CENTER (INVERTER PLANT)

2-13-1, Nishimiyachi, Yukuhashi, Fukuoka, 824-8511, Japan
Phone: 81-930-25-3844 Fax: 81-930-25-4369
<http://www.yaskawa.co.jp>

YASKAWA ELECTRIC CORPORATION

New Pier Takeshiba South Tower, 1-16-1, Kaigan, Minatoku, Tokyo, 105-6891, Japan
Phone: 81-3-5402-4502 Fax: 81-3-5402-4580
<http://www.yaskawa.jp>

YASKAWA AMERICA, INC.

2121 Norman Drive South, Waukegan, IL 60085, U.S.A.
Phone: (800) YASKAWA (927-5292) or 1-847-887-7000 Fax: 1-847-887-7310
<http://www.yaskawa.com>

YASKAWA ELÉTRICO DO BRASIL LDA.

Avenda Fagundes Filho, 620 Bairro Saude, São Paulo, SP04304-000, Brasil
Phone: 55-11-3585-1100 Fax: 55-11-5581-8795
<http://www.yaskawa.com.br>

YASKAWA EUROPE GmbH

Hauptstrasse 185, 65760 Eschborn, Germany
Phone: 49-6196-569-300 Fax: 49-6196-569-398
<http://www.yaskawa.eu.com>

YASKAWA ELECTRIC UK LTD.

1 Hunt Hill Orchardton Woods, Cumbernauld, G68 9LF, United Kingdom
Phone: 44-1236-735000 Fax: 44-1236-458182
<http://www.yaskawa.co.uk>

YASKAWA ELECTRIC KOREA CORPORATION

7F, Doore Bldg. 24, Yeoido-dong, Yeoungdongpo-gu, Seoul, 150-877, Korea
Phone: 82-2-784-7844 Fax: 82-2-784-8495
<http://www.yaskawa.co.kr>

YASKAWA ELECTRIC (SINGAPORE) PTE. LTD.

151 Lorong Chuan, #04-01, New Tech Park, 556741, Singapore
Phone: 65-6282-3003 Fax: 65-6289-3003
<http://www.yaskawa.com.sg>

YASKAWA ELECTRIC (SHANGHAI) CO., LTD.

No. 18 Xizang Zhong Road, 17F, Harbour Ring Plaza, Shanghai, 200001, China
Phone: 86-21-5385-2200 Fax: 86-21-5385-3299
<http://www.yaskawa.com.cn>

YASKAWA ELECTRIC (SHANGHAI) CO., LTD. BEIJING OFFICE

Room 1011, Tower W3 Oriental Plaza, No. 1 East Chang An Ave.,
Dong Cheng District, Beijing, 100738, China
Phone: 86-10-6518-4086 Fax: 86-10-6518-4082

YASKAWA ELECTRIC TAIWAN CORPORATION

9F, 16, Nanking E. Rd., Sec. 3, Taipei, 104, Taiwan
Phone: 886-2-2502-5003 Fax: 886-2-2505-1280



YASKAWA ELECTRIC CORPORATION

In the event that the end user of this product is to be the military and said product is to be employed in any weapons systems or the manufacture thereof, the export will fall under the relevant regulations as stipulated in the Foreign Exchange and Foreign Trade Regulations. Therefore, be sure to follow all procedures and submit all relevant documentation according to any and all rules, regulations and laws that may apply.

Specifications are subject to change without notice for ongoing product modifications and improvements.

© 2008-2010 YASKAWA ELECTRIC CORPORATION. All rights reserved.

MANUAL NO. TOBP C730600 36C

Published in Japan December 2010 08-7 -0

10-10-6