

Operating Instructions

VEGAMIP R61

Receiving unit

- Relay



Document ID:
35786

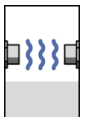

Radar

Contents

1	About this document	
1.1	Function	4
1.2	Target group	4
1.3	Symbolism used	4
2	For your safety	
2.1	Authorised personnel	5
2.2	Appropriate use	5
2.3	Warning about misuse	5
2.4	General safety instructions	5
2.5	CE conformity	6
2.6	Environmental instructions	6
3	Product description	
3.1	Configuration	7
3.2	Principle of operation	7
3.3	Packaging, transport and storage	9
3.4	Accessories and replacement parts	10
4	Mounting	
4.1	General instructions	12
4.2	Mounting instructions	12
5	Connecting to power supply	
5.1	Preparing the connection	19
5.2	Connection procedure	19
5.3	Wiring plan, single chamber housing	21
6	Setup	
6.1	Adjustment elements	22
6.2	Adjustment	23
7	Maintenance and fault rectification	
7.1	Maintenance	28
7.2	Rectify malfunctions	28
7.3	Exchange the electronics	29
7.4	How to proceed in case of repair	29
8	Dismounting	
8.1	Dismounting steps	30
8.2	Disposal	30
9	Supplement	
9.1	Technical data	31
9.2	Dimensions	34

**Safety instructions for Ex areas**

Please note the Ex-specific safety information for installation and operation in Ex areas. These safety instructions are part of the operating instructions manual and come with the Ex-approved instruments.

1 About this document

1.1 Function

This operating instructions manual provides all the information you need for mounting, connection and setup as well as important instructions for maintenance and fault rectification. Please read this information before putting the instrument into operation and keep this manual accessible in the immediate vicinity of the device.

1.2 Target group

This operating instructions manual is directed to trained qualified personnel. The contents of this manual should be made available to these personnel and put into practice by them.

1.3 Symbolism used



Information, tip, note

This symbol indicates helpful additional information.



Caution: If this warning is ignored, faults or malfunctions can result.

Warning: If this warning is ignored, injury to persons and/or serious damage to the instrument can result.

Danger: If this warning is ignored, serious injury to persons and/or destruction of the instrument can result.



Ex applications

This symbol indicates special instructions for Ex applications.



List

The dot set in front indicates a list with no implied sequence.



Action

This arrow indicates a single action.



Sequence

Numbers set in front indicate successive steps in a procedure.

2 For your safety

2.1 Authorised personnel

All operations described in this operating instructions manual must be carried out only by trained specialist personnel authorised by the plant operator.

During work on and with the device the required personal protective equipment must always be worn.

2.2 Appropriate use

The VEGAMIP 61 is a sensor for level detection.

You can find detailed information on the application range in chapter "*Product description*".

Operational reliability is ensured only if the instrument is properly used according to the specifications in the operating instructions manual as well as possible supplementary instructions.

2.3 Warning about misuse

Inappropriate or incorrect use of the instrument can give rise to application-specific hazards, e.g. vessel overflow or damage to system components through incorrect mounting or adjustment.

2.4 General safety instructions

This is a state-of-the-art instrument complying with all prevailing regulations and guidelines. The instrument must only be operated in a technically flawless and reliable condition. The operator is responsible for the trouble-free operation of the instrument.

During the entire duration of use, the user is obliged to determine the compliance of the necessary occupational safety measures with the current valid rules and regulations and also take note of new regulations.

The safety instructions in this operating instructions manual, the national installation standards as well as the valid safety regulations and accident prevention rules must be observed by the user.

For safety and warranty reasons, any invasive work on the device beyond that described in the operating instructions manual may be carried out only by personnel authorised by the manufacturer. Arbitrary conversions or modifications are explicitly forbidden.

The safety approval markings and safety tips on the device must also be observed.

The emitting frequencies of the sensors depend on the model, but are all in the K band range. The low transmitting power lies far below the internationally permitted limit value. When the instrument is used correctly, it presents no danger to human health. It may be operated without restriction outside of closed vessels.

2.5 CE conformity

The device fulfills the legal requirements of the applicable EC guidelines. By attaching the CE mark, VEGA provides a confirmation of successful testing. You can find the CE conformity declaration in the download area of www.vega.com.

2.6 Environmental instructions

Protection of the environment is one of our most important duties. That is why we have introduced an environment management system with the goal of continuously improving company environmental protection. The environment management system is certified according to DIN EN ISO 14001.

Please help us fulfil this obligation by observing the environmental instructions in this manual:

- Chapter "*Packaging, transport and storage*"
- Chapter "*Disposal*"

3 Product description

3.1 Configuration

Type label	<p>The type label contains the most important data for identification and use of the instrument:</p> <ul style="list-style-type: none">● Article number● Serial number● Technical data● Article numbers, documentation <p>With the serial number, you can access the delivery data of the instrument via www.vega.com, "VEGA Tools" and "serial number search". In addition to the type label outside, you can also find the serial number on the inside of the instrument.</p>
Serial number	<p>The serial number on the type label of the instrument allows you to have the order data, operating instructions manuals, sensor data for the service DTM as well as the test certificate (depending on the instrument) displayed via www.vega.com, "VEGA Tools" and "serial number search".</p>
Scope of delivery	<p>The scope of delivery typically consists of the following components.</p> <ul style="list-style-type: none">● Point level sensor VEGAMIP R61 (receiving unit)● Documentation<ul style="list-style-type: none">– this operating instructions manual– Supplementary instructions manual "<i>Plug connector for level sensors</i>" (optional)– Ex-specific "<i>Safety instructions</i>" (with Ex versions)– if necessary, further certificates● The corresponding emitting unit VEGAMIP T61 is described in a separate operating instructions manual.●

3.2 Principle of operation

Application area	<p>VEGAMIP 61 is a microwave barrier for level detection.</p> <p>It is designed for industrial use in all areas of process technology and can be used in bulk solids and liquids.</p> <p>Typical applications are overfill and dry run protection. With an operating distance of 100 m, VEGAMIP 61 can be used, for example, in bulk solids silos with large diameters. Thanks to its simple and rugged measuring system, VEGAMIP 61 is virtually unaffected by the process and the chemical and physical properties of the medium.</p> <p>VEGAMIP 61 can be also used for detection of vehicles and ships or for material recognition on conveyor belts.</p>
-------------------------	---

It works even under extremely difficult conditions, such as different granulation sizes, contamination, extreme filling noise, high temperatures, strong dust generation or abrasive products.

The VEGAMIP 61 consists of the following components.

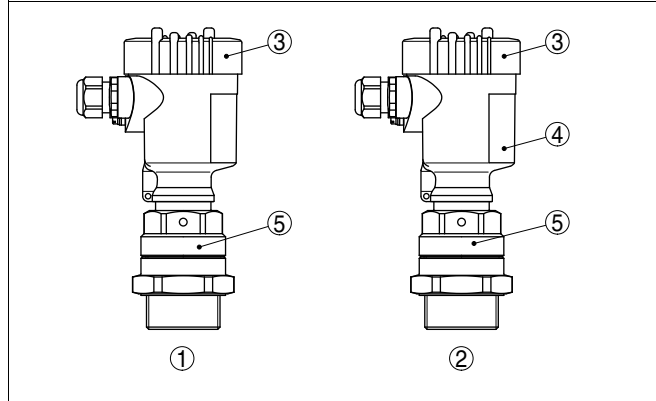

Fig. 1: VEGAMIP 61 with plastic housing

- 1 Emitting unit VEGAMIP T61
- 2 Receiving unit VEGAMIP R61 with control electronics
- 3 Housing cover
- 4 Housing with control electronics
- 5 Process fitting

Several antenna versions are available for different applications.

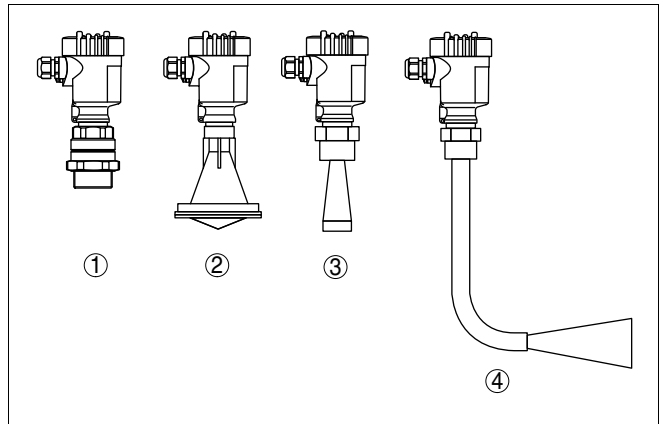

Fig. 2: Antenna versions

- 1 Encapsulated horn antenna with PTFE cover
- 2 Plastic encapsulated antenna with PP cover
- 3 Horn antenna
- 4 VEGAMIP 61 with angled antenna extension

Functional principle

The emitting unit transmits a focused microwave signal via horn antenna to the receiving unit on the opposite side. If there is medium between emitting and receiving unit, the signal is damped. This change is detected by the built-in electronics module and converted into a switching command.

3.3 Packaging, transport and storage

Packaging

Your instrument was protected by packaging during transport. Its capacity to handle normal loads during transport is assured by a test according to DIN EN 24180.

The packaging of standard instruments consists of environment-friendly, recyclable cardboard. For special versions, PE foam or PE foil is also used. Dispose of the packaging material via specialised recycling companies.

Transport

Transport must be carried out under consideration of the notes on the transport packaging. Nonobservance of these instructions can cause damage to the device.

Transport inspection

The delivery must be checked for completeness and possible transit damage immediately at receipt. Ascertained transit damage or concealed defects must be appropriately dealt with.

Storage

Up to the time of installation, the packages must be left closed and stored according to the orientation and storage markings on the outside.

Unless otherwise indicated, the packages must be stored only under the following conditions:

- Not in the open
- Dry and dust free
- Not exposed to corrosive media
- Protected against solar radiation
- Avoiding mechanical shock and vibration

Storage and transport temperature

- Storage and transport temperature see chapter "*Supplement - Technical data - Ambient conditions*"
- Relative humidity 20 ... 85 %

3.4 Accessories and replacement parts**Protective cover**

The protective cover protects the sensor housing against soiling and intense heat from solar radiation.

You will find additional information in the supplementary instructions manual "*Protective cover*" (Document-ID 34296).

Flanges

Flanges are available in different versions according to the following standards: DIN 2501, EN 1092-1, ANSI B 16.5, JIS B 2210-1984, GOST 12821-80.

You will find additional information in the supplementary instructions manual "*Flanges according to DIN-EN-ASME-JIS*" (Document-ID 31088).

Electronics module

The electronics module VEGAMIP R61 is a replacement part for microwave barriers of VEGAMIP series 60.

You will find additional information in the following operating instructions manual:

- "*Electronics module VEGAMIP R61 (receiving unit)*" (Document-ID 36428)

Mounting adapter

With high process temperatures exceeding 80 °C, you have to use a mounting adapter for the emitting and receiving unit. The mounting adapter can be only used with the encapsulated horn antenna with PTFE cover.

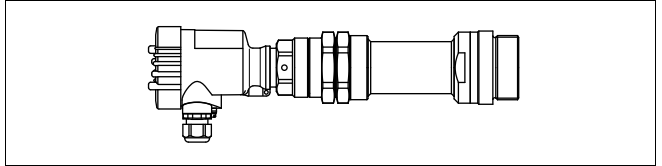

Fig. 3: VEGAMIP 61 with high temperature mounting adapter

4 Mounting

4.1 General instructions

Screwing in

With instruments with threaded process fitting, suitable tools must be applied for tightening the hexagon.

**Warning:**

The housing must not be used to screw the instrument in! Applying tightening force can damage internal parts of the housing.

Suitability for the process conditions

Make sure that all parts of the instrument exposed to the process, in particular the antenna, seal and process fitting, are suitable for the existing process conditions. These include above all the process pressure, process temperature as well as the chemical properties of the medium.

You can find the specifications in chapter "*Technical data*" or on the type label.

Moisture

Use the recommended cables (see chapter "*Connecting to power supply*") and tighten the cable gland.

You can give your instrument additional protection against moisture penetration by leading the connection cable downward in front of the cable entry. Rain and condensation water can thus drain off. This applies mainly to outdoor mounting as well as installation in areas where high humidity is expected (e.g. through cleaning processes) or on cooled or heated vessels.

4.2 Mounting instructions

Switching point

If possible, install VEGAMIP 61 in a position where a high signal damping by the medium is expected.

Avoid mounting the instrument too close to the vessel wall. Reflections from the vessel wall or from vessel installation can influence the switching accuracy.

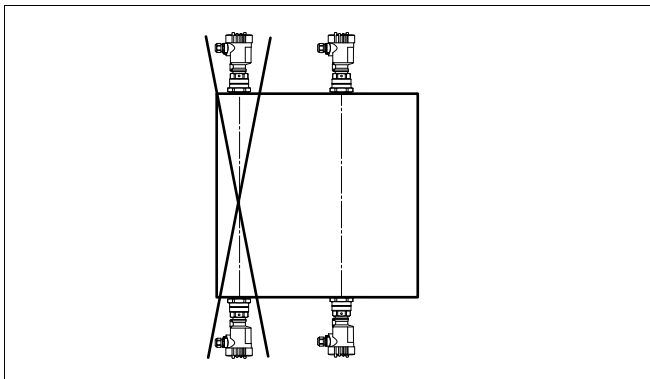

Fig. 4: Installation position (top view)

Inflowing medium

If VEGAMIP 61 is mounted in the filling stream, unwanted false measurement signals can be generated. For this reason, mount VEGAMIP 61 at a position in the vessel where no disturbances, e.g. from filling openings, agitators, etc., can occur.

Non-metallic vessels

Microwaves can penetrate non-conductive materials. Hence, it is possible to measure through the wall of non-conductive vessels.

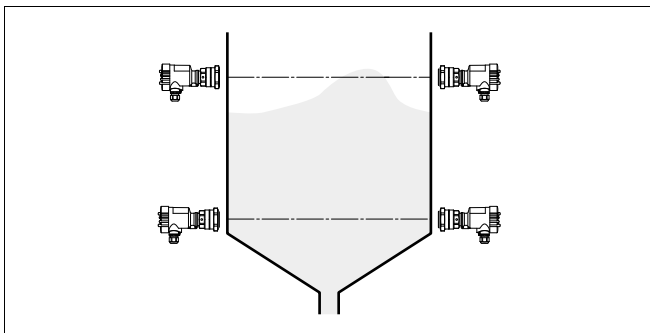

Fig. 5: Bulk solids vessel of plastic

Metal vessels

In metal vessels, you have to mount VEGAMIP 61 on flanges or threaded sockets. It is also possible to measure through a window. In general, all products such as glass, ceramic and plastic are suitable as window material.

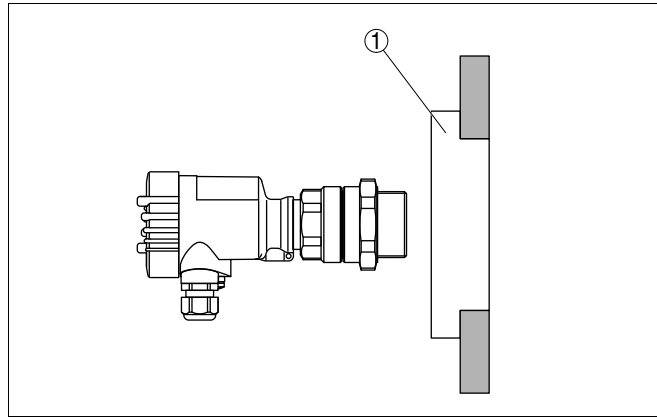

Fig. 6: Installation in front of a vessel window

1 Window of non-conductive material, for example, glass, plastic, etc.

Concrete vessel

In general, the same as for metal vessels applies to concrete vessels due to the steel braining.

Wood vessels

In general, the same as for metal vessels applies to wood vessels due to the liquid absorption of the wood.

Pipelines

VEGAMIP 61 can be used for detection of products in pipelines. In pipelines of non-metallic products such as plastic or glass, the measured product can be detected through the pipe wall.

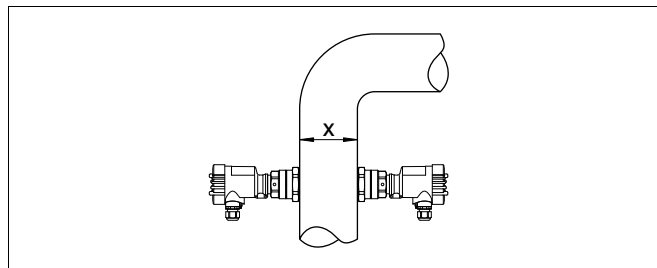

Fig. 7: Installation in pipelines

x Min. distance 100 mm (3.94 in)

Threaded version

Mount the threaded version of VEGAMIP 61 in the following way:

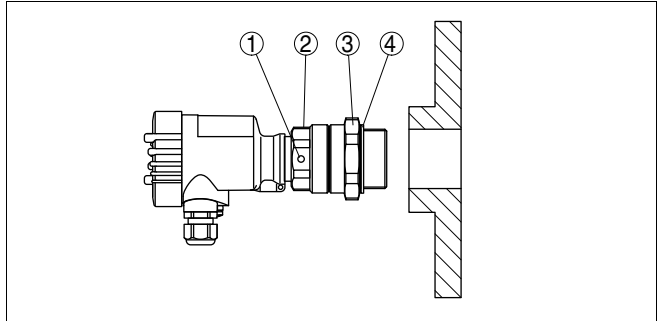

Fig. 8: VEGAMIP 61 - threaded version G1½ A

- 1 Polarisation marking
- 2 Instrument hexagon
- 3 Locknut
- 4 Process seal

- 1 Insert the supplied process seal (1) before screwing it in
- 2 To screw VEGAMIP 61 in, use the instrument hexagon (3) below the housing.
Screw the instrument in and hand-screw it a flat wrench
- 3 Turn the sensor back (max. 180°) to reach the required orientation of the polarisation marking (4)
- 4 Hold the instrument in this position and tighten with the counter nut (2)



Caution:

The housing must not be used to screw the instrument in! Applying tightening force can damage internal parts of the housing.



Note:

In the case of VEGAMIP 61 with NPT thread, the instrument seals in the thread itself. Hence, no counter nut is necessary for these versions.

Buildup

Avoid long sockets in which the medium can remain and if possible, mount VEGAMIP 61 front-flush. This applies mainly if buildup and dust are expected.

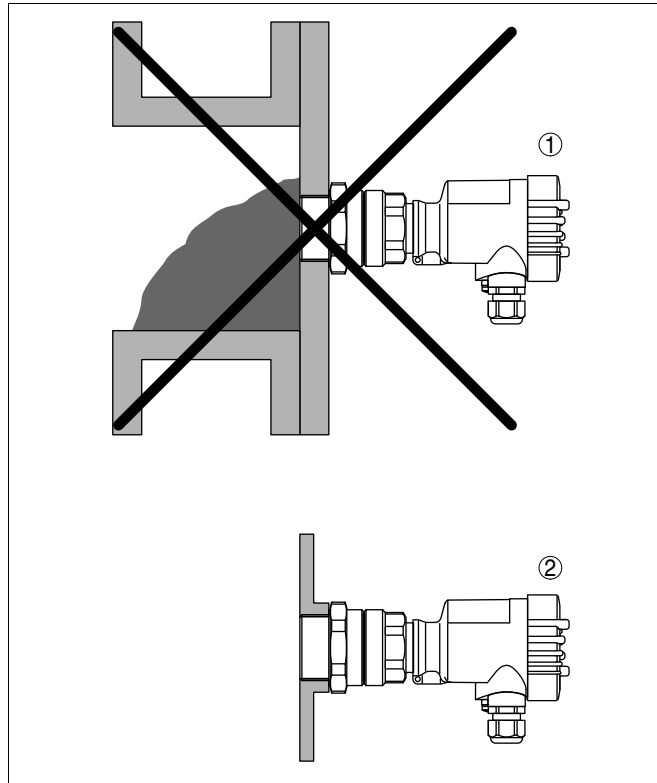

Fig. 9: Front-flush installation

- 1 Unfavourable installation - bulk solid can settle in front of the sensor
- 2 Correct front flush installation

Abrasive medium

In very abrasive products, VEGAMIP 61 should be installed with a mounting adapter or in front of a suitable window. In this case, you have to use a window material which is appropriately resistant.

Orientation of the sensor

For an optimum switching signal, the two sensors must be adapted to each other. The accuracy must be in a range of $\pm 5^\circ$.

General rule: the bigger the antenna and the better it focusses, the more precise the orientation has to be.

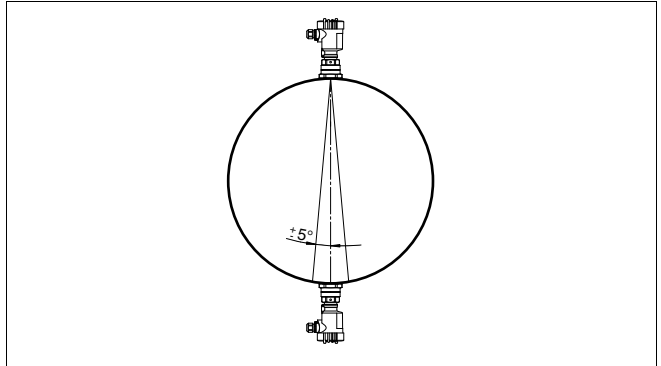

Fig. 10: Orientation of the sensors

The emitting unit emits electromagnetic waves. The polarisation plane is the direction of the electrical wave component. Its position is marked on the instrument hexagon by polarisation markings.

For a reliable function, the emitting and receiving unit must be installed in the same polarisation direction.

If several instrument pairs are installed in a vessel, the instrument pairs can be coded by different polarisation positions to avoid that they influence one another.

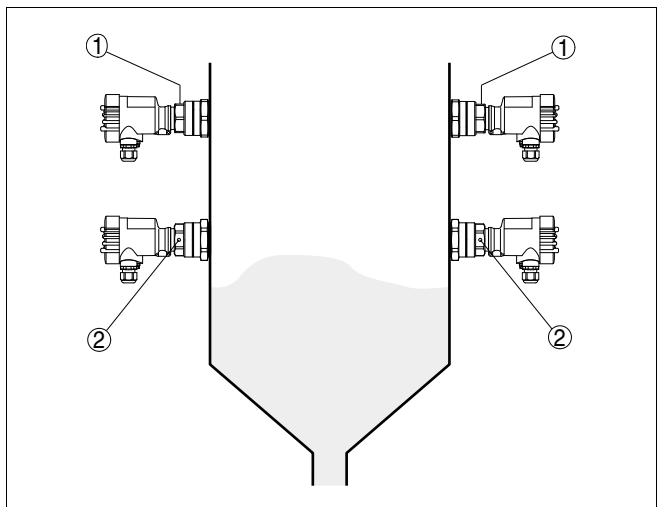

Fig. 11: Orientation according to the polarisation direction

- 1 Polarisation marking on top
- 2 Polarisation marking lateral

Special mounting options

In tight mounting spaces or spaces subject to high temperatures, the signal of VEGAMIP 61 can be guided via a deflector. You can use a metal plate for this or an angled antenna extension on the side of the emitting unit. In products with low dielectric value, we recommend using an instrument version with antenna extension because it focusses the signal optimally and has no signal loss. With instrument versions with detachable horn antenna, the antenna extension can be retrofitted.

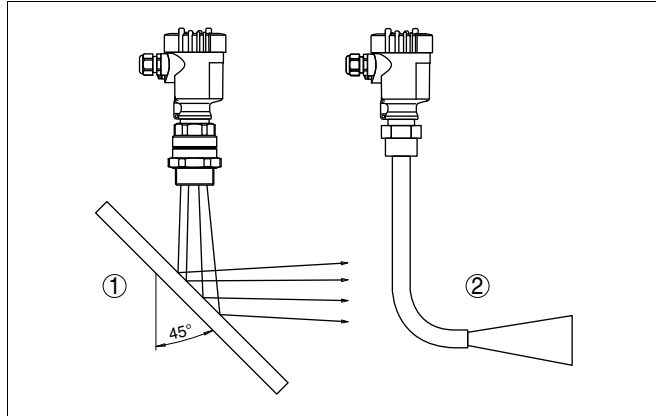

Fig. 12: Possibilities for signal deflection

- 1 Metal plate for signal deflection of the microwave signal
- 2 Bent antenna extension

5 Connecting to power supply

5.1 Preparing the connection

Safety instructions

Always keep in mind the following safety instructions:

- Connect only in the complete absence of line voltage
- If overvoltages are expected, install overvoltage arresters

Voltage supply

Connect the operating voltage according to the following diagrams. The oscillator with relay output is designed in protection class 1. To maintain this protection class, it is absolutely necessary that the ground conductor be connected to the internal ground terminal. Take note of the general installation regulations. As a rule, connect VEGAMIP 61 to vessel ground (PA), or in case of plastic vessels, to the next ground potential. On the side of the housing there is a ground terminal between the cable entries. This connection serves to drain off electrostatic charges. In Ex applications, the installation regulations for hazardous areas must be given priority.

The data for power supply are specified in chapter "*Technical data*".

Connection cable

The instrument is connected with standard two-wire cable without screen. If electromagnetic interference is expected which is above the test values of EN 61326 for industrial areas, screened cable should be used.

Use cable with round cross-section. A cable outer diameter of 5 ... 9 mm (0.2 ... 0.35 in) ensures the seal effect of the cable gland. If you are using cable with a different diameter or cross-section, exchange the seal or use a suitable cable gland.

5.2 Connection procedure

Connection technology

The connection of the voltage supply and the signal output is carried out via the spring-loaded terminals in the housing.

Connection procedure

Proceed as follows:

- 1 Unscrew the housing cover
- 2 Loosen compression nut of the cable entry
- 3 Remove approx. 10 cm (4 in) of the cable mantle, strip approx. 1 cm (0.4 in) of insulation from the ends of the individual wires

- 4 Insert the cable into the sensor through the cable entry



Fig. 13: Connection steps 4 and 5

- 5 Insert the wire ends into the terminals according to the wiring plan



Information:

Solid cores as well as flexible (stranded) cores with wire end sleeves are inserted directly into the terminal openings. If you are using flexible cores without end sleeves, press with a small screwdriver on the terminal, the terminal opening is freed. When the screwdriver is released, the terminal closes again.

- 6 Check the hold of the wires in the terminals by lightly pulling on them
- 7 Connect the screen to the internal ground terminal, connect the outer ground terminal to potential equalisation
- 8 Tighten the compression nut of the cable entry. The seal ring must completely encircle the cable
- 9 Screw the housing cover on

The electrical connection is finished.



Information:

The terminal block is pluggable and can be removed from the electronics. For this purpose, lift the terminal block with a small screwdriver and pull it out. When inserting the terminal block again, you should hear it snap in.

5.3 Wiring plan, single chamber housing

Wiring plan

We recommend connecting VEGAMIP 61 in such a way that the switching circuit is open when there is a level signal, line break or failure (safe condition).



Information:

The relays are always shown in non-operative condition.

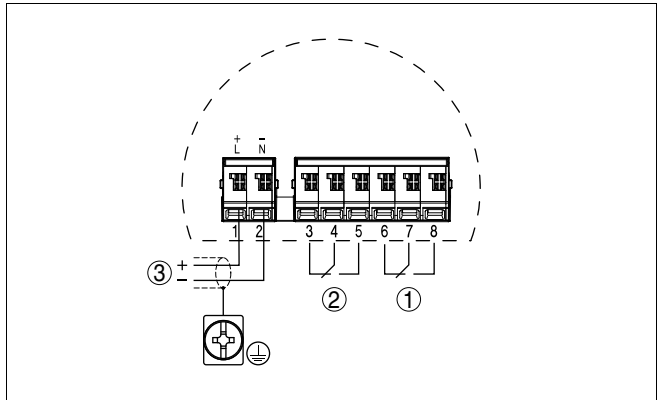

Fig. 14: Wiring plan receiving unit - VEGAMIP 61 (receiver)

- 1 Relay output
- 2 Relay output
- 3 Voltage supply

6 Setup

6.1 Adjustment elements

The figures in brackets refer to the following illustration.

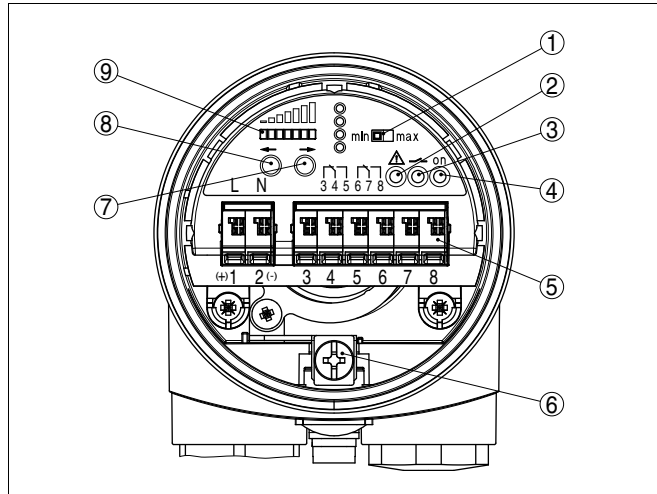

Fig. 15: Electronics module MPE60R receiver unit - Relay output

- 1 Mode switch for selecting the switching behaviour (min./max.)
- 2 Control lamp (LED) for indication of a fault (red)
- 3 Signal lamp (LED) for indication of the switching condition (yellow)
- 4 Control lamp (LED) for indication of the instrument function (green)
- 5 Connection terminals
- 6 Ground terminal
- 7 Key for adjustment of the sensitivity and the switching delay (-->)
- 8 Key for adjustment of the sensitivity and the switching delay (<--)
- 9 LED indicating board for indication of the receiving level (yellow)

Signal lamps (2, 3, 4)

There are three signal lamps (LED) on the electronics module

Control lamp (red) for indication of a fault (2)

This signal lamp shows the fault status of the instrument.

Control lamp (yellow) for indication of the switching condition (3)

The signal lamp signals the switching condition of the switching output.

Control lamp (green) for indication of the instrument function (4)

The green signal lamp (on) shows the operating state of the instrument as soon as voltage supply is connected correctly.

Mode adjustment (1)

With the mode adjustment (max./min.) you can change the switching condition of the relay. You can set the required mode according to the "Function chart" (max. - max. detection or overflow protection, min. - min. detection or dry run protection).

Sensitivity adjustment (7, 8)

With these keys (7 and 8) you can adjust the switching point to the medium.

Depending on the process, the sensitivity of VEGAMIP 61 adjusted more or less sensitive.

Pressing the "<--" key makes the sensor more sensitive. Pressing the "-->" key makes the sensor less sensitive.

You can also adjust the switching delay with the two keys.

LED indication strip - receiving level (9)

By means of the LED indicating board, you can see the actual receiving level during adjustment.

When the indication moves to the right, the instrument will be more insensitive, to the left more sensitive.

6.2 Adjustment

Prerequisites



The microwave barrier can only be adjusted when being uncovered. Make sure that there is no measured medium or vessel installations between the emitting and receiving unit.

Mode

Select the requested mode (min./max.) according to the function chart.

The following function chart provides an overview of the switching conditions depending on the adjusted mode and level.

	Level	Switching status	Signal lamp - Relay (yellow)
Mode max. Overflow protection		 Relay energized	
Mode max. Overflow protection		 Relay deenergized	
Mode min. Dry run protection		 Relay energized	
Mode min. Dry run protection		 Relay deenergized	

	Level	Switching status	Signal lamp - Relay (yellow)
Failure of the supply voltage (max./min. mode)	any	 Relay deenergized	○
Failure	any	 Relay deenergized	○ Red failure LED lights

Depending on the switching function your relay output should carry out, you can determine the switching direction by means of the slide switch.

- For max. indication or overflow protection set the slide switch to position max.
- For min. indication or dry run protection, set the slide switch to position min.

The relay is energized if the yellow relay control lamp lights.

Sensitivity adjustment

With the two keys you can change the LED indication strip and adjust the switching point to the medium.

The keys are lowered to avoid unintentional changes of the setting. For adjustment, use for example, a small screwdriver.

If you press one of the keys for more than two seconds, the adjustment range shifts automatically in the respective direction. The greater the distance between emitting and receiving unit, the greater the adjustment range of the indication. The LED indication strip always shows a small section of the actual measuring range.

Pressing the "<--" key makes the sensor more sensitive. Pressing the "-->" key makes the sensor less sensitive.

Press the respective key until the indication is within the LED indication strip. This means one or two LEDs on the LED indication strip light up.

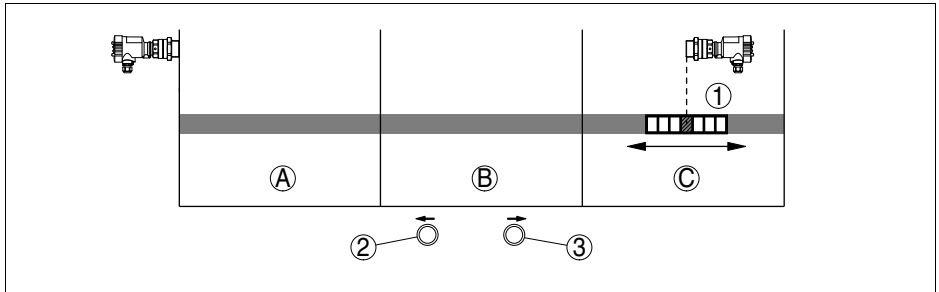

Fig. 32: Indication board

- 1 Indication (LED indication board)
- 2 More sensitive - Key to the left
- 3 Less sensitive - Key to the right
- A Medium: Plastics (PP, PVC ...), solvents
- B Medium: Building material (sand, stones ...)
- C Medium: Conductive substances (coal, ore, salt ...)

Set the indication approximately to the middle of the LED indicating board until the yellow relay control lamp changes condition.

Depending on the vessel size, process and/or medium, you have to adjust the sensitivity of VEGAMIP 61 more or less sensitive. In products with low signal damping, in small vessels or pipelines or with buildup, it can be necessary to test the switching function.

Receiving level

By means of the LED indicating board, you can see the actual receiving level during adjustment.

When the indication moves to the right, the instrument will be more insensitive, to the left more sensitive.

Medium delivers good signal damping

In applications with products having a good signal damping (for example stones, ore, sand, cement) and where buildup and contamination is expected, you should adjust the instrument more insensitive. In this case, the VEGAMIP 61 switches only with a relatively high signal damping by the medium. Probable buildup does not influence the measurement.

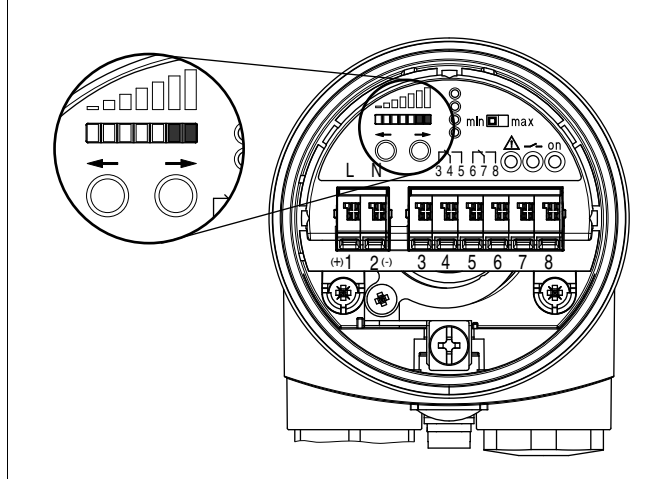

Fig. 33: LED indication strip - Setting for products with good signal damping

Product delivers low signal damping

In applications with products having a low signal damping (for example plastic granules, cereals), you should adjust the instrument more sensitive. Hence, the VEGAMIP 61 switches very sensitive, even with relatively low covering by the product.

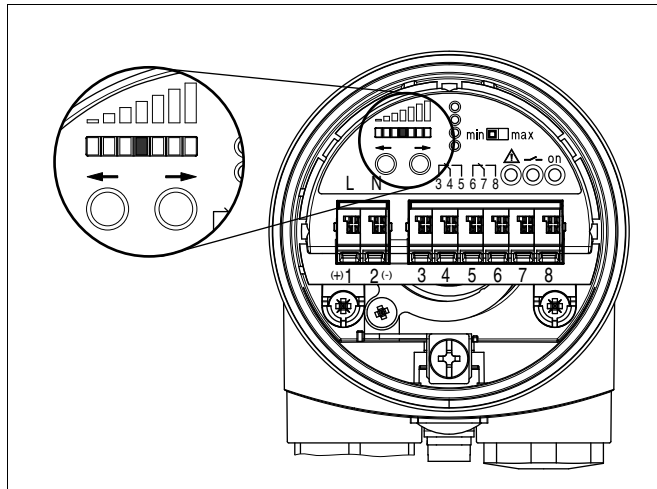

Fig. 34: LED indication strip - Setting for products with low signal damping

Switching delay

By means of the LED indicating board, you can adjust the switching delay.

Push the two keys (7) and (8) simultaneously for approximately 2 s until the LED indication flashes.

With the two keys you can select the requested switching delay according to the following illustration.

The switching delay can be adjusted in seven steps between 100 ms and 20 s.

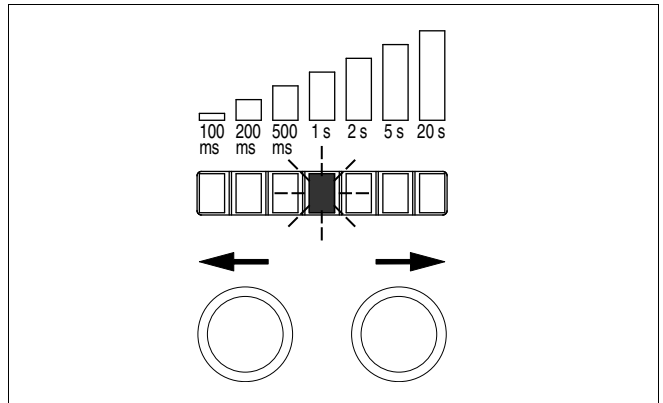

Fig. 35: Adjust switching delay - LED indication flashes

If the indication moves to the right, the switching delay will be longer, to the left shorter.

The indication returns automatically to the indication of the actual receiving level after approximately 10 s.

Simulation

If possible, you can simulate a filling between emitting and receiving unit by using the hand or a metal sheet and check if the switching point is adjusted correctly. If the relay control lamp changes the switching condition, then the switching function is correct.

7 Maintenance and fault rectification

7.1 Maintenance

When the device is used correctly, no maintenance is required in normal operation.

7.2 Rectify malfunctions

Reaction when malfunctions occur

The operator of the system is responsible for taking suitable measures to remove interferences.

Fault rectification

The first measure to be taken is to check the output signal. In many cases, the causes can be determined this way and the faults rectified.

Checking the switching signal

Error	Cause	Removal
VEGAMIP 61 signals "covered" when the vibrating element is not submerged (overflow protection) or VEGAMIP 61 signals "uncovered" when the vibrating element is submerged (dry run protection)	Operating voltage too low	Check operating voltage
	Buildup on the sensor	Check if there is buildup on the two sensors, and if so, remove it.
	Wrong mode selected	Set the correct mode on the mode switch (max.: overflow protection, min.: dry run protection). Wiring should be carried out according to the quiescent current principle.
	Unfavourable installation location	Mount the sensor (emitter/receiver) in a position where there is a lot of measured product between emitting and receiving unit.
	Electronics defective	Press the mode switch. If the instrument then does not change the mode, the electronics module is defective. Exchange the electronics module.
	Sensor defective	Push the mode switch (min./max.). If the instrument switches over, the sensor can be covered or mechanically damaged. Should the switching function on the correct mode be wrong again, the you should return the instrument for repair.
Signal lamp lights red	Operating voltage too low	Check operating voltage
	Electronics module has detected an internal failure	Exchange the instrument or send it in for repair
Instrument switches delayed	Check switching delay	Adjust switching delay correctly

Reaction after fault rectification

Depending on the failure reason and measures taken, the steps described in chapter "Set up" must be carried out again, if necessary.

24 hour service hotline

However, should these measures not be successful, call the VEGA service hotline in urgent cases under the phone no. **+49 1805 858550**.

The hotline is available to you 7 days a week round-the-clock. Since we offer this service world-wide, the support is only available in the English language. The service is free of charge, only the standard telephone costs will be charged.

7.3 Exchange the electronics

If the electronics module is defective, it can be replaced by the user.



In Ex applications only one electronics module with respective Ex approval may be used.

You find all information to the electronics exchange in the operating instructions of the new electronics module.

7.4 How to proceed in case of repair

If a repair is necessary, please proceed as follows:

You can download a return form (23 KB) from our Internet homepage www.vega.com under: "*Downloads - Forms and certificates - Repair form*".

By doing this you help us carry out the repair quickly and without having to call back for needed information.

- Print and fill out one form per instrument
- Clean the instrument and pack it damage-proof
- Attach the completed form and, if need be, also a safety data sheet outside on the packaging
- Please ask the agency serving you for the address of your return shipment. You can find the competent agency on our website www.vega.com.

8 Dismounting

8.1 Dismounting steps

**Warning:**

Before dismantling, be aware of dangerous process conditions such as e.g. pressure in the vessel, high temperatures, corrosive or toxic products etc.

Take note of chapters "*Mounting*" and "*Connecting to power supply*" and carry out the listed steps in reverse order.

8.2 Disposal

The instrument consists of materials which can be recycled by specialised recycling companies. We use recyclable materials and have designed the electronics to be easily separable.

WEEE directive 2002/96/EG

This instrument is not subject to the WEEE directive 2002/96/EG and the respective national laws. Pass the instrument directly on to a specialised recycling company and do not use the municipal collecting points. These may be used only for privately used products according to the WEEE directive.

Correct disposal avoids negative effects to persons and environment and ensures recycling of useful raw materials.

Materials: see chapter "*Technical data*"

If you have no way to dispose of the old instrument properly, please contact us about return and disposal.

9 Supplement

9.1 Technical data

General data

Material 316L corresponds to 1.4404 or 1.4435

Materials, wetted parts

– Process fitting - thread	316L
– Process fitting - flange	316L
– Process seal	Klingsil C-4400
– Instrument seal	FKM (Viton)
– Antenna cover	PP, PTFE
– Cover - Mounting adapter (optional)	Ceramic Al ₂ O ₃
– Seal - Mounting adapter (optional)	Graphite

Materials, non-wetted parts

– Housing plastic	plastic PBT (Polyester)
– Aluminium die-casting housing	Aluminium die-casting AlSi10Mg, powder-coated - basis: Polyester
– Stainless steel housing - precision casting	316L
– Stainless steel housing, electropolished	316L
– Seal between housing and housing cover	NBR (stainless steel housing, investment casting), silicone (Aluminium/plastic housing, stainless steel housing, electro-polished)
– Ground terminal	316L
– Mounting adapter (option)	316L

Sensor length See chapter "*Dimensions*"

Instrument weight (depending on process fitting) 0.8 ... 4 kg (0.18 ... 8.82 lbs)

Process fittings

– Pipe thread, cylindrical (ISO 228 T1)	G1½ A
– American pipe thread, tapered	1½ NPT
– Flanges	DIN from DN 50, ANSI from 2"

Frequency range K band, 24.085 GHz (ISM band)

Measuring range 0.1 ... 100 m (0.33 ... 328 ft)

Angle of aperture of the antenna 3 dB

– Encapsulated horn antenna (G1½ A)	20 °
– Plastic encapsulated antenna with PP cover	10 °

Output variable

Output Relay output, 2 floating spdts

Relay data

- AC 5 A, 253 V AC
- DC 4 A, 30 V DC; 0.2 A, 125 V DC

Breaking capacity

If inductive loads or stronger currents are switched through, the gold plating on the relay contact surface will be permanently damaged. The contact is then no longer suitable for switching low-level signal circuits.

Contact material (relay contacts)

AgNi or AgSnO and Au plated

Modes (adjustable)

- max. Max. detection or overflow/overflow protection
- min. Min. detection or dry run protection

Measuring accuracy

- Hysteresis approximately 1 dB
- Switching delay adjustable from 0.1 ... 20 s (on/off)
- Min. distance 100 mm (3.94 in)

Ambient conditions

- Ambient, storage and transport temperature -40 ... +80 °C (-40 ... +176 °F)

Process conditions

- Measured variable Limit level of bulk solids and liquids
- Process pressure

 - VEGAMIP 61 antenna with PTFE cover -1 ... 4 bar/-100 ... 400 kPa (-14.5 ... 58 psig)
 - VEGAMIP 61 antenna with PP cover -1 ... 2 bar/-100 ... 200 kPa (-14.5 ... 29 psig)
 - VEGAMIP 61 with mounting adapter unpressurized (IP 67)

- Process temperature (thread or flange temperature)

 - VEGAMIP 61 antenna with PTFE cover -40 ... +80 °C (-40 ... +176 °F)
 - VEGAMIP 61 antenna with PP cover -40 ... +80 °C (-40 ... +176 °F)
 - VEGAMIP 61 with mounting adapter 150 mm (optional) -40 ... +250 °C (-40 ... +482 °F)
 - VEGAMIP 61 with mounting adapter 300 mm (optional) -40 ... +450 °C (-40 ... +842 °F)

Electromechanical data**Cable entry/plug (dependent on the version)**

- Single chamber housing
 - 1 x cable entry M20 x 1.5 (cable: \varnothing 5 ... 9 mm), 1 x blind stopper M20 x 1.5; attached 1 x cable entry M20 x 1.5
- or:

- 1 x cable entry ½ NPT, 1 x blind stopper ½ NPT, 1 x cable entry ½ NPT

or:

- 1 x plug M12 x 1; 1 x blind stopper M20 x 1.5 for wire cross-section up to 1.5 mm² (AWG 16)

Screw terminals

Voltage supply

Operating voltage	20 ... 253 V AC, 50/60 Hz, 20 ... 72 V DC (at U > 60 V DC, the ambient temperature can be max. 50 °C/122 °F)
Power consumption	1 ... 8 VA (AC), approximately 1.3 W (DC)

Electrical protective measures

Protection rating	IP 66/IP 67
Overvoltage category	III
Protection class	I

Approvals

Depending on the version, instruments with approvals can have different technical data.

For these instruments, the corresponding approval documents have to be taken into account. These are part of the delivery or can be downloaded under www.vega.com via "VEGA Tools" and "serial number search" as well as via "Downloads" and "Approvals".

9.2 Dimensions

VEGAMIP 61 - housing versions

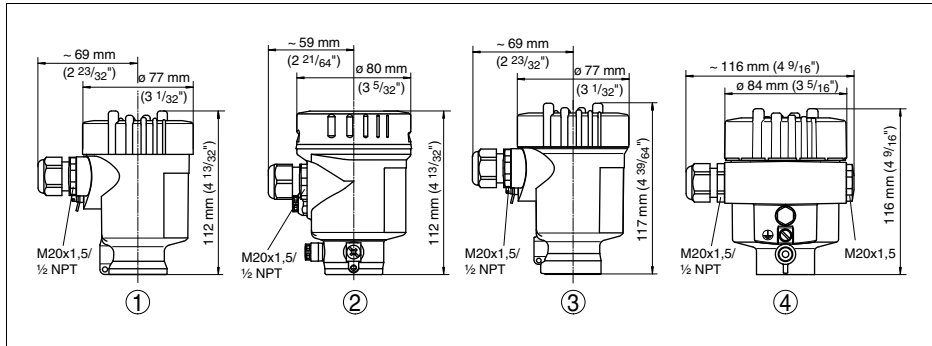

Fig. 36: Housing versions

- 1 Housing plastic
- 2 Stainless steel housing, electropolished
- 3 Stainless steel housing - precision casting
- 4 Aluminium housing

VEGAMIP 61

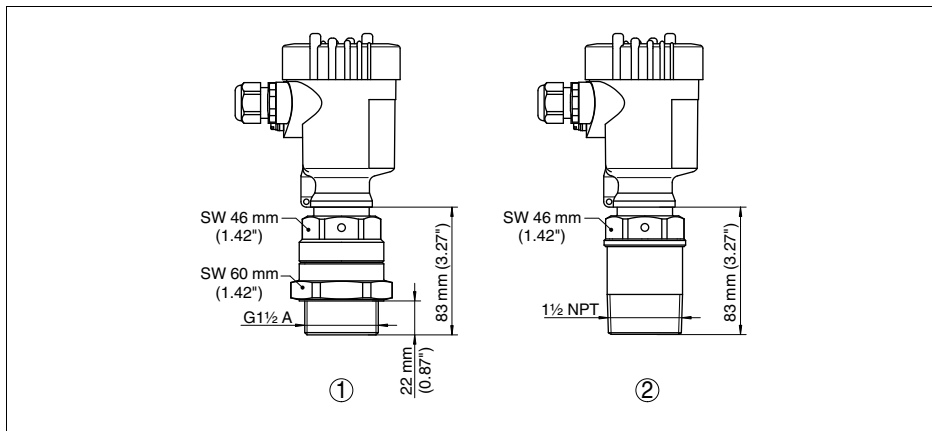

Fig. 37: VEGAMIP 61

- 1 Threaded version - encapsulated horn antenna with PTFE cover - G1 1/2 A
- 2 Threaded version - encapsulated horn antenna with PTFE cover - 1 1/2 NPT

VEGAMIP 61

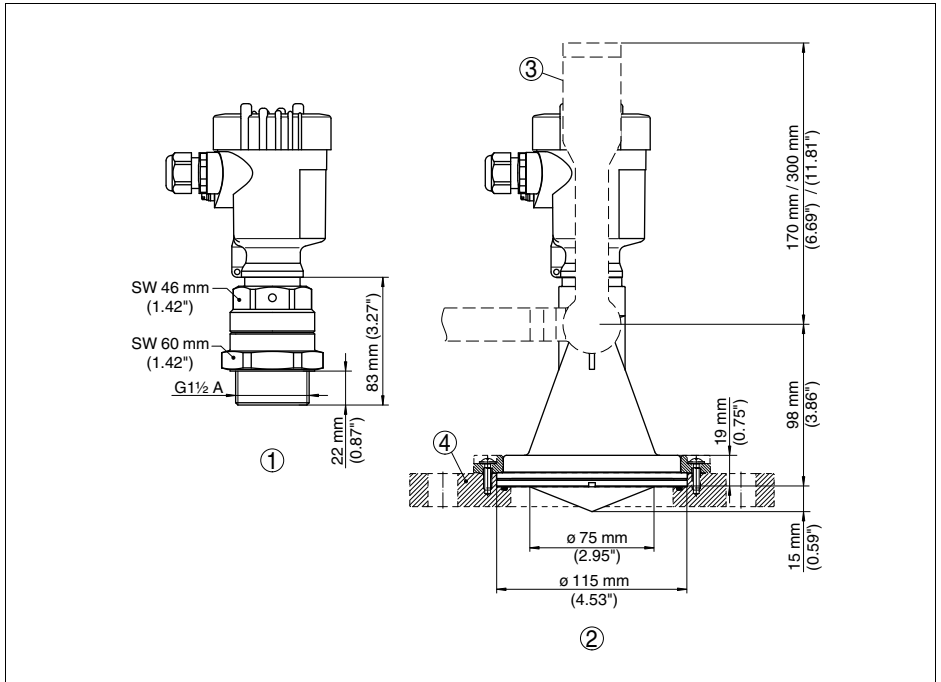

Fig. 38: VEGAMIP 61

- 1 Threaded version - encapsulated horn antenna with PTFE cover - G1½ A
- 2 Plastic encapsulated antenna with PP cover
- 3 Mounting strap
- 4 Adapter flange

VEGAMIP 61 - Mounting adapter (-40 ... +450 °C)

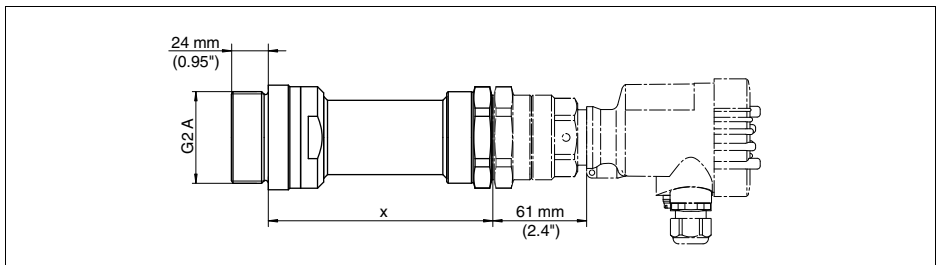

Fig. 39: Mounting adapter with ceramic cover for VEGAMIP 61 - threaded version with PTFE cover
 x 150 mm (5.9 in) or 300 mm (11.8 in)

9.3 Industrial property rights

VEGA product lines are global protected by industrial property rights. Further information see <http://www.vega.com>.

Only in U.S.A.: Further information see patent label at the sensor housing.

VEGA Produktfamilien sind weltweit geschützt durch gewerbliche Schutzrechte.

Nähere Informationen unter <http://www.vega.com>.

Les lignes de produits VEGA sont globalement protégées par des droits de propriété intellectuelle. Pour plus d'informations, on pourra se référer au site <http://www.vega.com>.

VEGA líneas de productos están protegidas por los derechos en el campo de la propiedad industrial. Para mayor información revise la pagina web <http://www.vega.com>.

Линии продукции фирмы ВЕГА защищаются по всему миру правами на интеллектуальную собственность. Дальнейшую информацию смотрите на сайте <http://www.vega.com>.

VEGA系列产品在全球享有知识产权保护。
进一步信息请参见网站<<http://www.vega.com>>。

9.4 Trademark

All the brands as well as trade and company names used are property of their lawful proprietor/originator.

INDEX

A

Abrasion 16
Accessory
– Flanges 10
– Protective cover 10
Application area 7

B

Bending 18
Buildup 15

C

Cable 19
Cable screening 19

E

Electronics module 10, 29
Emitting unit 8

F

Fault rectification 28
Filling opening 13
Functional principle 9

M

Mode 23
Moisture 12
Mounting adapter 11

O

Orientation of the sensor 16

P

Pipelines 14
Potential equalisation 19

R

Receiving unit 8, 21-22

S

Sensitivity adjustment 24
Serial number 7
Service hotline 29
Shielding 19
Simulation 27
Switching delay 27
Switching point 12

T

Type label 7

V

Vessel type
– Concrete vessel 14
– Metal vessels 13
– Non-metallic vessels 13
– Wood vessels 14



Printing date:

VEGA Grieshaber KG
Am Hohenstein 113
77761 Schiltach
Germany
Phone +49 7836 50-0
Fax +49 7836 50-201
E-mail: info@de.vega.com
www.vega.com



All statements concerning scope of delivery, application, practical use and operating conditions of the sensors and processing systems correspond to the information available at the time of printing.

© VEGA Grieshaber KG, Schiltach/Germany 2010