

Load Cell Troubleshooting

Scope

Load cells are designed to sense force or weight under a wide range of adverse conditions; they are not only the most essential part of an electronic weighing system, but also the most vulnerable.

Load cells might be damaged because of (shock) overloading, lightning strikes or heavy electrical surges in general, chemical or moisture ingress, mishandling (dropping, lifting on cable, etc.), vibration or internal component malfunction. As a direct result the scale or system might (zero) drift, provide unstable/unreliable readings or not register at all.

This application note is written to assist our customers with potential load cell problems. It describes basic field tests which can be performed on site, and provides the information necessary to interpret the results.

Proper field evaluation is absolutely critical to prevent similarly induced damage in the future! Under no circumstances should fault location, as described below, be attempted on load cells installed in a hazardous area!

In General

Carefully check the system integrity before evaluating the load cells:

- Check for force shunts (might be caused by dirt, mechanical misalignment or accompanying components such as stay- or check rods).
- Check for damage, corrosion or significant wear in the areas of load introduction.
- Check cable connections to junction box and indicator.
- Check the measuring device or indicator with an accurate load cell simulator.

Visually inspect the load cells before performing the tests as described on the following pages. Pay particular attention to signs of corrosion (especially around the critical gauge area), the integrity of the cable (might be compromised due to cuts, abrasions, etc) and the condition of the cable entry.

The following test equipment is required to properly evaluate a load cell:

- A high quality, calibrated, digital volt- and ohmmeter with a measuring accuracy of $\pm 0.5\Omega$ and ± 0.1 mV, to measure the zero balance and integrity of the bridge circuit.
- A megohm meter, capable of reading 5000 M Ω with an accuracy of 500 M Ω at 50 volts, to measure the insulation resistance. *Do not use megohm meters which supply more than 50 volts to the load cell, in order to prevent permanent damage!*
- A means to lift the dead load (weighbridge, tank, hopper, conveyor, etc.) off the load cell to be able to measure the zero balance or to remove the load cell(s), i.e. a crane, hydraulic jack, etc.

Load cells are produced according to specifications and tolerances which are described in the applicable data sheet. More detailed information can be found on the calibration certificate which is packed with each load cell. The calibration certificate mentions the exact values for the input and output resistance, insulation resistance, zero balance, rated output and the correct wiring code; *it provides an important reference for the values which can be measured and should be filed with the system documentation set.*

Load Cell Troubleshooting

Test Procedures and Analysis

The diagram below represents a proposed sequence for testing load cells after a particular system malfunction. Isolate the fault location by moving a relatively small deadweight over each load cell, or by disconnecting load cell by load cell.

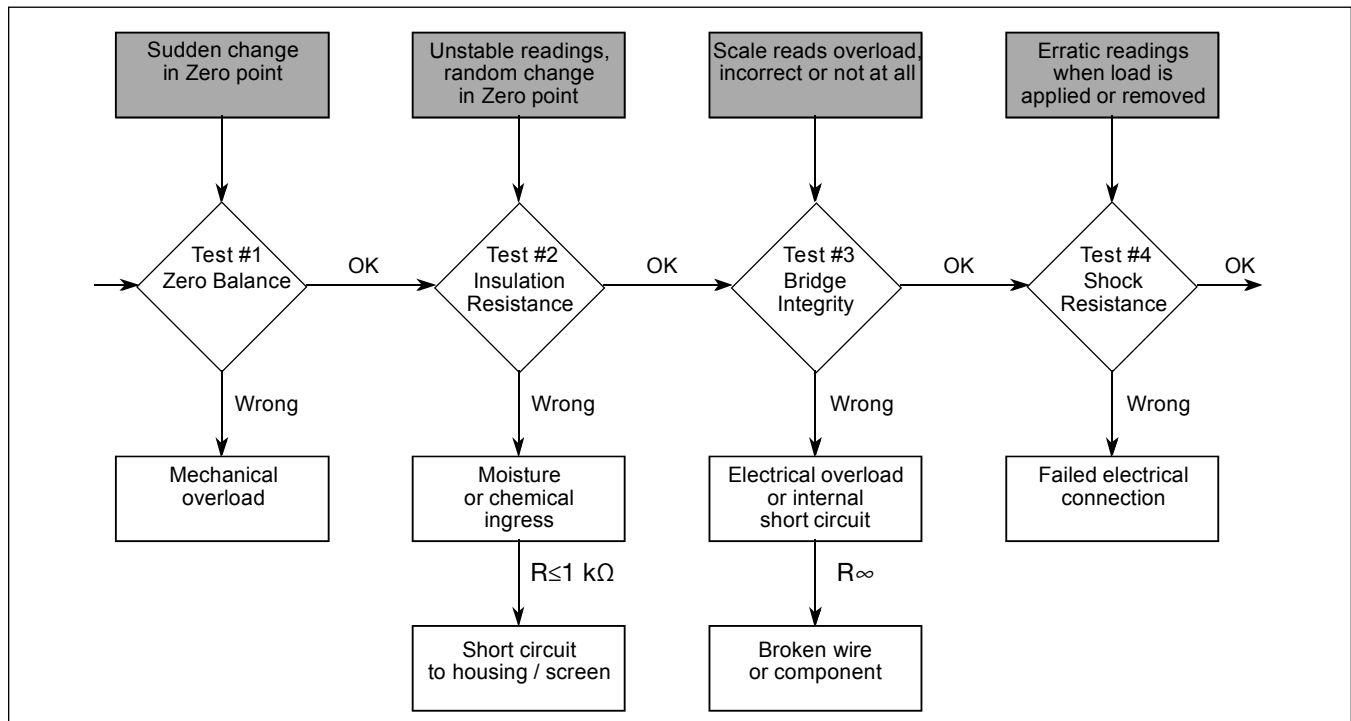

Test #1: Zero Balance

The Zero Balance is defined as the load cell output in a "no-load" situation. Therefore, all weight (including deadload) has to be removed from the load cell. Low capacity load cells should be measured in the position in which the load cell is designed to measure force to prevent the weight of the element giving wrong results.

APPLICATION NOTE The load cell should be connected to a stable power supply, preferably a load cell indicator with an excitation voltage of at least 10 volts. Disconnect any other load cell for multiple load cell systems.

Measure the voltage across the load cell's output leads with a millivoltmeter and divide this value by the input or excitation voltage to obtain the Zero Balance in mV/V. Compare the Zero balance to the original load cell calibration certificate (if available) or to the data sheet.

Analysis

Changes in Zero Balance usually occur if the load cell has been permanently deformed by overloading and/or excessive shocks. Load cells that experience progressive

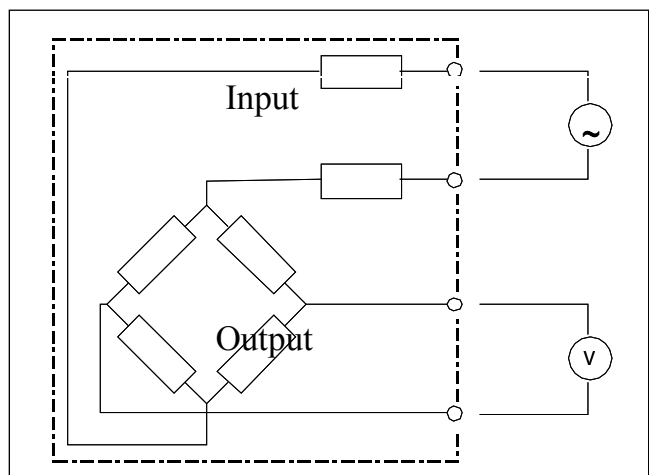

zero output changes per time period are most likely undergoing a change in the strain gauge resistance because of chemical or moisture intrusion. However, in this case the insulation resistance and/or the bridge integrity will also be compromised.

Load Cell Troubleshooting

Test #2: Insulation Resistance

The insulation resistance is measured between the load cell circuit and element or cable shield. Disconnect the load cell from the junction box or indicator and connect all input, output and sense (if applicable) leads together.

Measure the insulation resistance with a megohmmeter between these four or six connected leads and the load cell body. Repeat the measurement between the same 4 or 6 leads and the cable shield. Finally measure the insulation resistance between the load cell body and cable shield.

Never use a megohmmeter to measure the input or output resistance, as it normally operates at a voltage which exceeds the maximum excitation voltage by far!

Analysis

The insulation resistance of all load cells should be 5000 M Ω or more for bridge circuit to housing, bridge circuit to cable screen and housing to cable screen.

A lower value indicates electrical leakage, which is usually caused by moisture or chemical contaminations within the

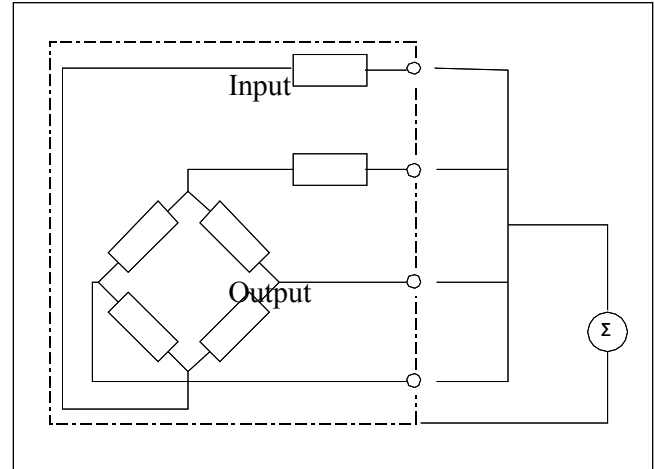

load cell or cable. Extremely low values ($\leq 1k \Omega$) indicate a short circuit rather than moisture ingress.

Electrical leakage results usually in unstable load cell or scale reading output. The stability might vary with temperature.

Test #3: Bridge Integrity

The bridge integrity is verified by measuring the input and output resistance as well as the bridge balance. Disconnect the load cell from the junction box or measuring device.

The input and output resistance is measured with an ohmmeter across each pair of input and output leads. Compare the input and output resistance to the original calibration certificate (if available) or to the data sheet specifications.

The bridge balance is obtained by comparing the resistance from -output to -input, and -output to +input. The difference between both values should be smaller than, or equal to 1 Ω .

Analysis

Changes in bridge resistance or bridge balance are most often caused by a broken or burned wire, an electrical component failure or internal short circuit. This might

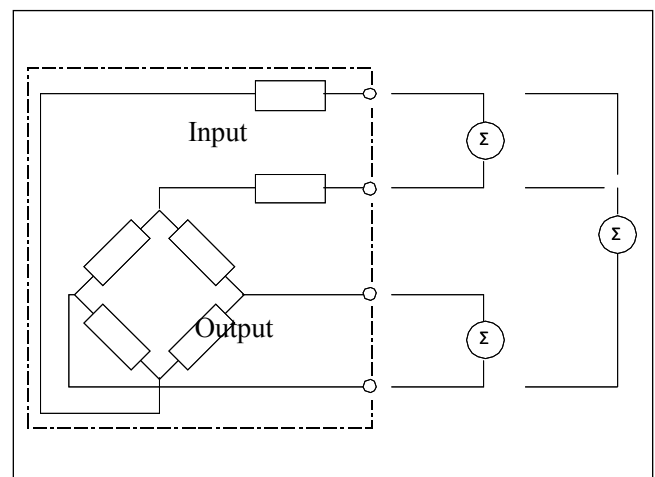

result from over-voltage (lightning or welding), physical damage from shock, vibration or fatigue, excessive temperature, or from production inconsistencies.

APPLICATION NOTE

Load Cell Troubleshooting

Test #4: Shock Resistance

The load cell should be connected to a stable power supply, preferably a load cell indicator with an excitation voltage of at least 10 volts. Disconnect all other load cells for multiple load cell systems.

With a voltmeter connected to the output leads, lightly rap on the load cell with a small mallet to mildly shock it. *Exercise extreme care not to overload low capacity load cells while testing their shock resistance.*

Watch the readings during the test. The readings should not become erratic, should remain reasonably stable and return to original zero readings.

Analysis

Erratic readings may indicate a failed electrical connection or a damaged glue layer between strain gauge and element as a result of an electrical transient.

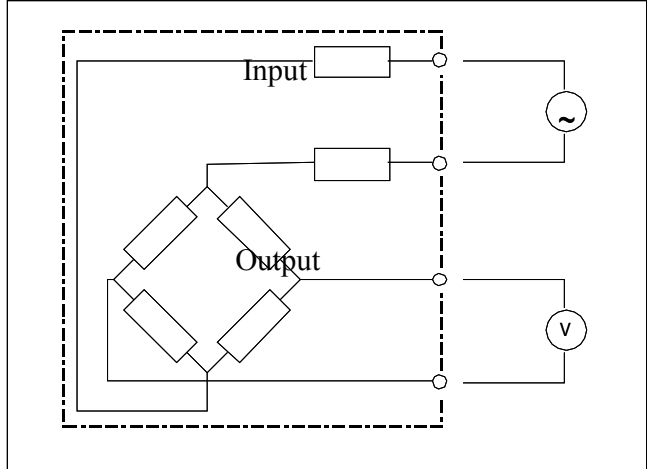

Load Cell Evaluation Form

The following load cell evaluation form should be used as a guide for the testing and evaluation of load cells. We recommend that this form be included in the customer dossier and used as the basis to discuss the test results and diagnostics with third parties.

If a load cell is returned to VPG Transducers, the Evaluation Form will assist our repair department in further diagnostics and repair of the cell.

Load Cell Troubleshooting

Load Cell Evaluation Form

Company: _____ Contact person: _____
 Address: _____ City / Country: _____
 Tel. / Fax.: _____ Repair order: _____ Date: _____

Load cell type: _____ Serial number: _____
 Capacity: _____ Accuracy grade: _____

Short description of system failure and application: _____

Visual Inspection			
Label	<input type="checkbox"/> OK	<input type="checkbox"/> Unreadable	<input type="checkbox"/> Missing
Condition	<input type="checkbox"/> Like new <input type="checkbox"/> Broken welds	<input type="checkbox"/> Cable cut <input type="checkbox"/> Visual mechanical overload	<input type="checkbox"/> J-box damage <input type="checkbox"/> Dents/cracks in parts
Corroded parts	<input type="checkbox"/> Weld(s) <input type="checkbox"/> Housing/element	<input type="checkbox"/> J-box/cable entry <input type="checkbox"/> Top/bottom plate	<input type="checkbox"/> Diaphragm <input type="checkbox"/> Bellow/tube/cubs
Affected by chemicals	<input type="checkbox"/> No	<input type="checkbox"/> Unknown	<input type="checkbox"/> Yes: _____
Electrical Inspection			
Bridge Measurements	Actual	Specification	Conclusion
Zero balance	mV/V	$\leq \pm 1\%$ of rated span	<input type="checkbox"/> OK <input type="checkbox"/> Wrong
Input resistance	Ω	$\Omega \pm 1\%$	<input type="checkbox"/> OK <input type="checkbox"/> Wrong
Output resistance	Ω	$\Omega \pm 1\%$	<input type="checkbox"/> OK <input type="checkbox"/> Wrong
Output – to input –	Ω		<input type="checkbox"/> OK <input type="checkbox"/> Wrong
Out put – to input +	Ω	difference $\leq \pm 1\%$	<input type="checkbox"/> OK <input type="checkbox"/> Wrong
Insulation Resistance	Actual	Specification	Conclusion
Bridge to housing	M Ω	≥ 5000 M Ω	<input type="checkbox"/> OK <input type="checkbox"/> Wrong
Bridge to shield	M Ω	≥ 5000 M Ω	<input type="checkbox"/> OK <input type="checkbox"/> Wrong
Shield to housing	M Ω	≥ 5000 M Ω	<input type="checkbox"/> OK <input type="checkbox"/> Wrong
Expected Reason for Failure			
<input type="checkbox"/> Moisture ingress	<input type="checkbox"/> Short circuit	<input type="checkbox"/> Broken wire/component	<input type="checkbox"/> Excessive heat
<input type="checkbox"/> Electrical transients	<input type="checkbox"/> Mechanical overload	<input type="checkbox"/> Excessive corrosion	<input type="checkbox"/> Broken cable
<input type="checkbox"/> Other: _____			

Recommendation

- Return load cell to supplier for further evaluation and repair (if possible)
- Return load cell to supplier for warranty
- Load cell beyond (economic) repair
- _____