



**SM Tech**

**BOSCHERT**



- flexible
- reliable
- reasonably priced

**Manual de intretinere  
a sculelor de stantat**

**User manual for  
maintenance of  
punching tools**



# Contents

<b>1</b>	<b>Copyright</b> .....	<b>4</b>
<b>2</b>	<b>Preface</b> .....	<b>4</b>
<b>3</b>	<b>Grinding of the tooling</b> .....	<b>4</b>
3.1	Necessity of grinding .....	4
3.2	Effective grinding .....	5
3.3	We suggest to grind the punching tools: .....	6
<b>4</b>	<b>Die clearance</b> .....	<b>7</b>
4.1	Correct die clearance .....	7
4.2	Wrong die clearance .....	7
4.3	Determination of the clearance for dies for system Boschert.....	8
<b>5</b>	<b>Punching force computation</b> .....	<b>9</b>
5.1	Calculating punching force .....	10
5.2	Punching performance schedule 28 tons for round tools .....	11
5.3	Punching performance schedule 40 tons for round tools .....	12
<b>6</b>	<b>Insertion depth</b> .....	<b>13</b>
<b>7</b>	<b>The maximum punching diameter</b> .....	<b>14</b>
7.1	Computation of the maximum punching diameter .....	14
<b>8</b>	<b>Service life increase</b> .....	<b>15</b>
8.1	Optimization of the steel grade or the degree of hardness from the tools ..	15
8.2	Titanium nitride (TIN)/Titancarbonitrid (TICN) coated tools.....	15
8.3	Titanium nitride (TIN) coating .....	15
8.4	Titancarbonitrid (TICN) coating .....	16
8.5	Using of suitable coolant and lubricants .....	16
8.6	Relief produced by grinding of punches .....	16
8.7	Corner radius by punches .....	17
8.8	Punch whisper version .....	18
8.9	Obtainable constructions of punches with whisper .....	19
<b>9</b>	<b>Heavy duty tooline</b> .....	<b>20</b>
9.1	Using of tools reinforced version .....	20
9.2	Punching tools “reinforced version“ / heavy duty tools .....	21
9.3	Heavy punch .....	21
9.4	Heavy adjusting ring inclusive wedge strengthened form .....	21
9.5	Heavy dies .....	21

<b>10</b>	<b>Machines with rotation .....</b>	<b>22</b>
10.1	Using of multiple radius tools.....	23
<b>11</b>	<b>Tool dimensions .....</b>	<b>24</b>
11.1	Punch chuck with insert size 0 (0-6,0) and (6,01-10,5): .....	24
11.2	Punch revotool .....	24
11.3	Die revotool .....	25
11.4	Die size 1, 2 and 3 flat .....	26
11.5	Die size 1, 2 and 3 whisper .....	26
11.6	Die size 1 .....	27
11.7	Die size 2 .....	27
11.8	Die size 3 .....	27
<b>12</b>	<b>Form position .....</b>	<b>28</b>
12.1	Definition of the form position from a punch into the sheet .....	28
12.2	Standard using for dies size III system Boschert.....	28
<b>13</b>	<b>Providing a punching tool .....</b>	<b>29</b>
13.1	Special features of the polyurethane stripper (PU) .....	30
13.2	Adjusting a forming tool .....	31
13.3	Strippper.....	32
13.4	PU- Stripper .....	32
13.5	Steel stripper .....	32
13.6	Tool change with PU; punch Ø 10,5 - Ø 30mm .....	33
<b>14</b>	<b>Revotool .....</b>	<b>34</b>
14.1	General information about Revotool .....	34
14.2	Informations about revotool punch and die holder .....	35
14.3	Special stripper for thin material thickness < 1mm.....	36
14.4	In that way you won't damage your tools unnessessary by working of borders .....	37
14.5	Maintenance .....	38-39
14.6	Spare Parts .....	40
	Example: order sheet revotool 6 - ways / 6 mm .....	41
	Order sheet: revotool 4-, 6-, 7-, 8- ways / 6 mm .....	42-45
<b>15</b>	<b>Spare parts revotool .....</b>	<b>46</b>
	Spare parts revotool 4-, 6-,7-, 8- ways / 6 mm.....	46-50
<b>16</b>	<b>Special tools.....</b>	<b>49</b>
16.1	Special form .....	49
16.2	Forming tool .....	50-51
<b>17</b>	<b>Service and Order .....</b>	<b>54</b>
<b>18</b>	<b>Trouble shouting .....</b>	<b>55-56</b>

## 1 Copyright

---

This manual is in copyright matters protected. All rights also those of the translation the reproduction and the duplication of the manual or from parts are reserved. No part of the manual may be multiplied and spread without written permission of the company L. Boschert in any form.

## 2 Introduction

---

For interruption of the punching machine are problems of the tools often responsible.

**Please read the following information about tools attentively.**

## 3 Grinding of the tooling

---

### 3.1 Necessity of grinding

---

Regular grinding of the tools guarantees a constant punch quality and increases the tool life as well as protects your punching machine.

## 3.2 Effective grinding

The lifetime of a punching tool depends of the size and the shape of the tool as well as the type and thickness of material being punched.

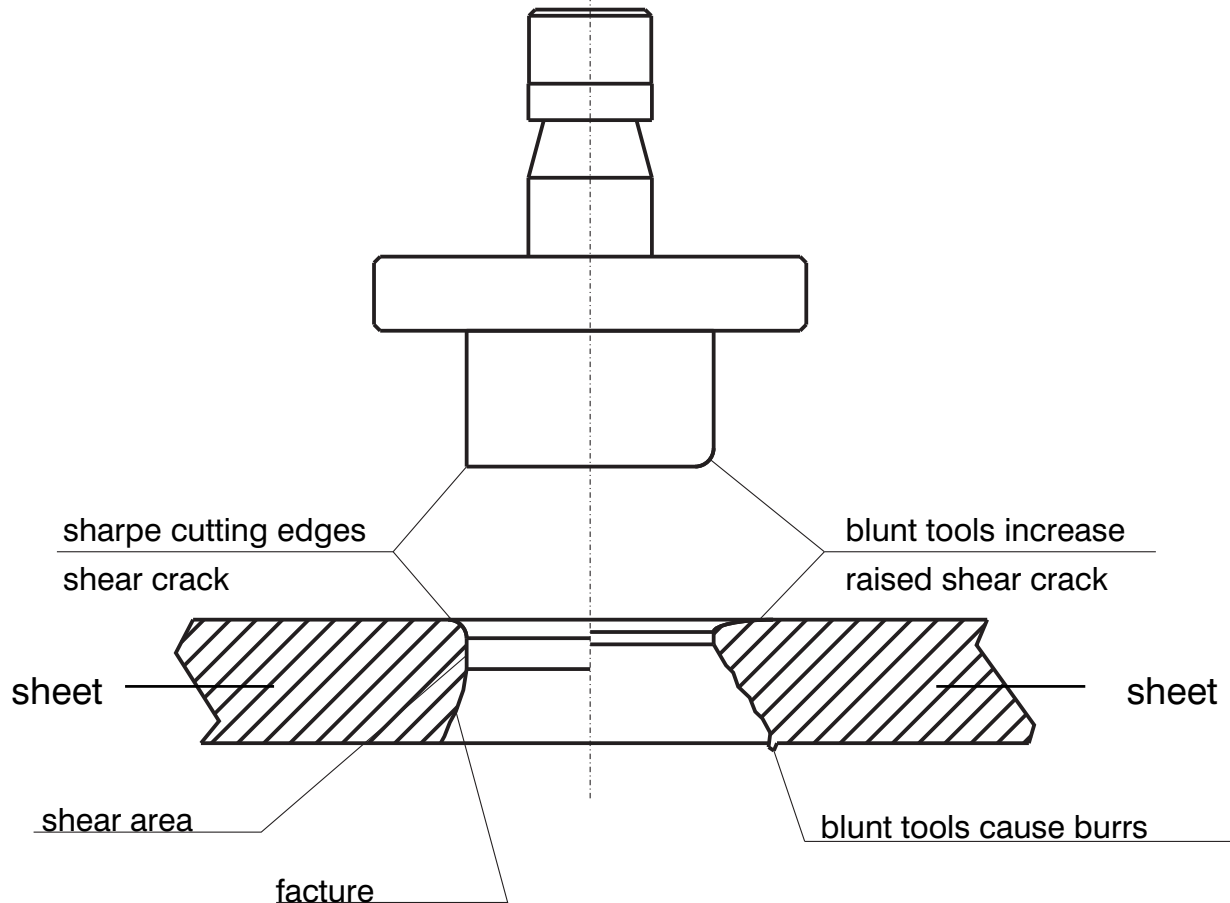

**A regular examination is necessary on the basis of the following criterion:**

- has the noise level increased when punching with the same tool?
- does the cutting edge have a radius of more than 0,1 mm?
- has the quality of the punched holes becomes more worse?
- has a structure cut formed at the cut surface?
- are slugs pulled during the upward stroke?



radius 0,1 mm (0.004 in.)

### 3.3 We suggest to grind the punching tools:

## Boschert tool grinding machine

# EASY SHARP



**Price per inquiry!**

	<b>Metric</b>	<b>Inch</b>
Grinding wheel diameter	175 mm	7 in.
Grinding wheel speed	2825 rpm	2825 rpm
Vertical adjustment	150 mm	6 in.
Hand wheel increment	0,02 mm	0.0008 in.
Working area	400 x 150 mm	15.7 x 6 in.
Working height of table	1100 mm	43.3 in.
Overall size including frame	1400 x 800 mm	55.2 x 31.5 in.
Overall height of machine	1600 mm	63.0 in.
Weight	226 kg	499 lbs.
Motor power	0,75 Kw	1 HP
Fuse protection	3 x 10 A	3 x 10 A

## 4 Die clearance

### 4.1 Correct die clearance

The die clearance depends on several factors, e.g. of the materials type and the sheet thickness.

**By a correct die clearance the service life of your tools extends!**

### 4.2 Wrong cut play

<b>Die clearance too less</b>	<ul style="list-style-type: none"><li>- The punch is loaded too strong.</li><li>- The die is loaded too strong.</li></ul>	Service life being shorten				
<b>Die clearance too much</b>	<ul style="list-style-type: none"><li>- Slug pulling</li></ul>	<ul style="list-style-type: none"><li>- Slug pulling the punch slug falls not in the waste container, but can pull itself upward and blocks themselves</li></ul>				
b	e	t	w	e	e	n
slug				die and sheet metal. The material is pulled therefore from the pliers. For this reason we recommend our punch stop in the dies.		
				- large burr at punching		The sheet metal becomes useless (out shot).

## 4.3 Determination of the die clearance with dies system Boschert

### F = Material multiplication factor :

<b>Spring steel</b>	:	F = 0,30 mm
<b>Stainless steel</b> e.g. 1.4301	:	F = 0,20 mm
<b>Cold rolled steel</b> e.g. St1203 / St 37	:	F = 0,20 mm
<b>Aluminium</b> e.g. AlMg3	:	F = 0,15 mm
<b>Copper</b>	:	F = 0,20 mm

### Die Ø DMA:

- 1 = D    Punch
- 2 = S    Material thickness
- 3 = DMA Die

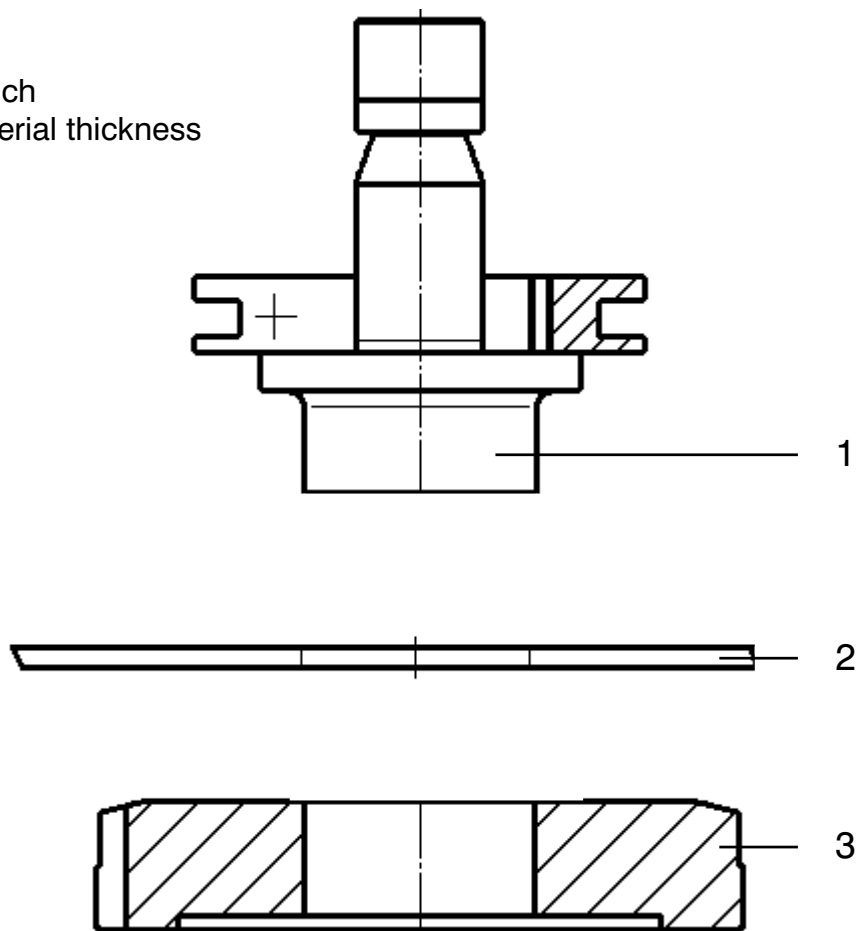

$$\text{Punch (D)} + (\text{Factor (F)} \times \text{Material thickness (S)}) = \text{Die (DMA)}$$

$$\text{Example: } 20 + (0,2 \times 5) = 21$$



# Punching force calculation



## 5 Calculation of the punching force

### Factor:

The height of the factor from 0.8 mm by using of punches with whisper shear (WT), has been resulted on our long-term experience.

$$\text{Punching force} = \frac{\text{tool extent} \times \text{material thickness} \times \text{tensile strength material} \times \text{factor } 0,8}{9810 \text{ (conversion of Nm in tons)}}$$

**ATTENTION! The punching strength of 28 (and/or 40) tons may not be exceeded!**

### Example 1:

Puch obround whisper (WT)	:	10 x 100	mm
Material thickness	:	5	mm
Tensile strength material	:	420	NM (steel)

$$(10 \times 3,14) \times 180 \times 5 \times 420 \times 0,8 = 355152 : 9810 = 36,2 \text{ To}$$

➡ Punching strength is not sufficient!

### Example 2:

Punch round flat (FL)	:	10	mm
Material thickness	:	3	mm
Tensile strength material	:	720	NM (stainless steel)

$$(10 \times 3,14) \times 3 \times 720 = 67824 : 9810 = 6,9 \text{ To}$$

➡ Punching strength is sufficient!

# Calculating punching force

## 5.1 Calculating punching force:

### Round:

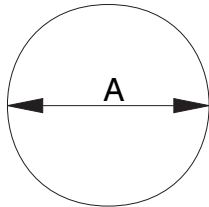

$$\begin{aligned} \text{Diameter A} &= \emptyset \\ \text{Extent L} &= 3,14 \times A \end{aligned}$$

### Square:

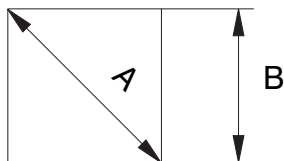

$$\begin{aligned} \text{Diameter A} &= \sqrt{2} \times B \\ \text{Extent L} &= 4 \times B \end{aligned}$$

### Rectangle:

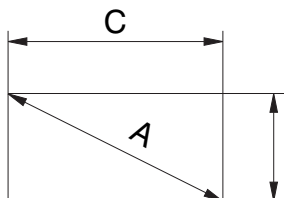

$$\begin{aligned} \text{Diameter A} &= \sqrt{B^2 + C^2} \\ \text{Extent L} &= 2 \times (C + B) \end{aligned}$$

### Obround:

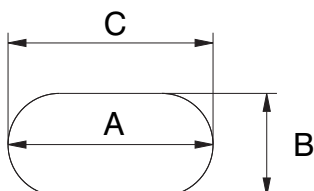

$$\begin{aligned} \text{Diameter A} &= C \\ \text{Extent L} &= 2 \times (C - B) + B \times 3,14 \end{aligned}$$

### Special tools:

### *On inquiry*

## 5.2 Punching performance schedule 28 tons for round tools

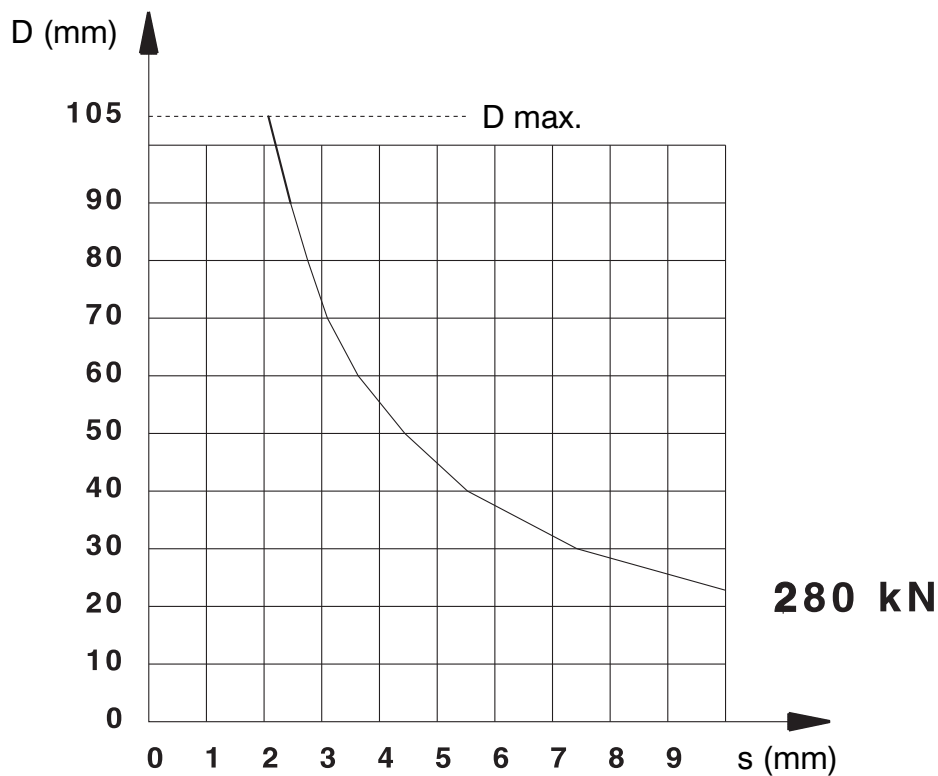

Punching performance schedule for tools flat shape (without consideration of the punching diameter increase use of punches with shear whisper) with steel sheet with tensile strength 280 N/mm.

## 5.3 Punching performance schedule 40 tons for round tools

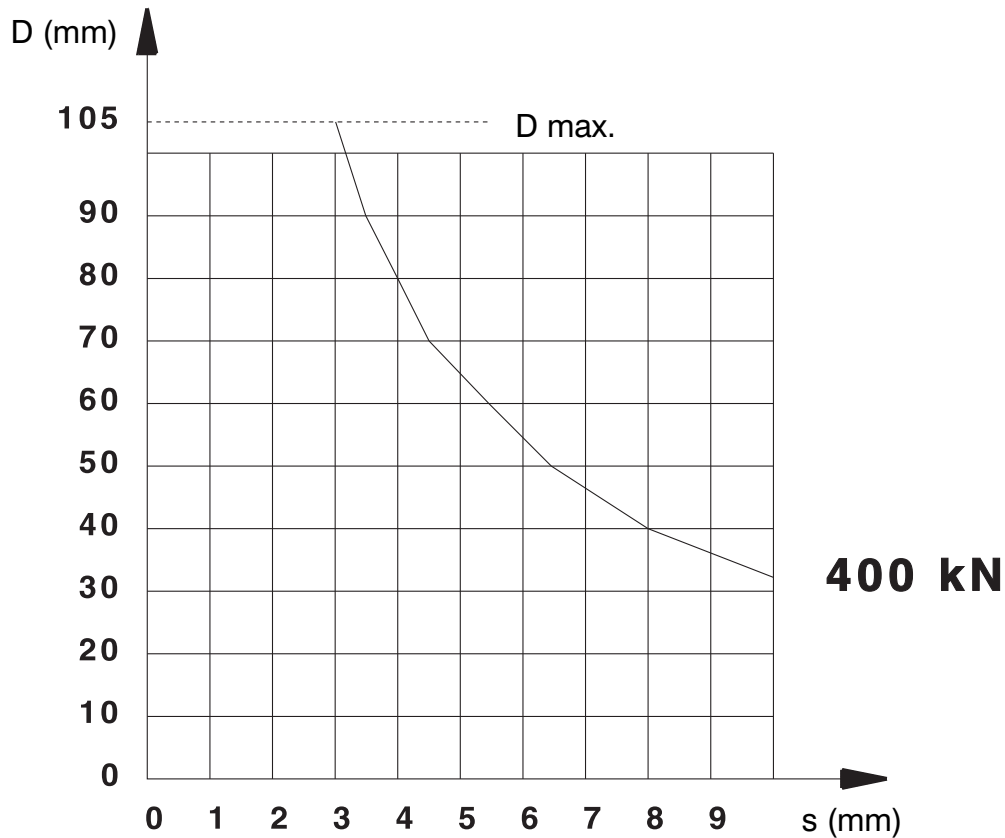

Punching performance schedule for tools flat shape (without consideration of the punching diameter increase use of punches with shear whisper) with steel sheet with tensile strength 400 N/mm.

## 6 Insertion depth

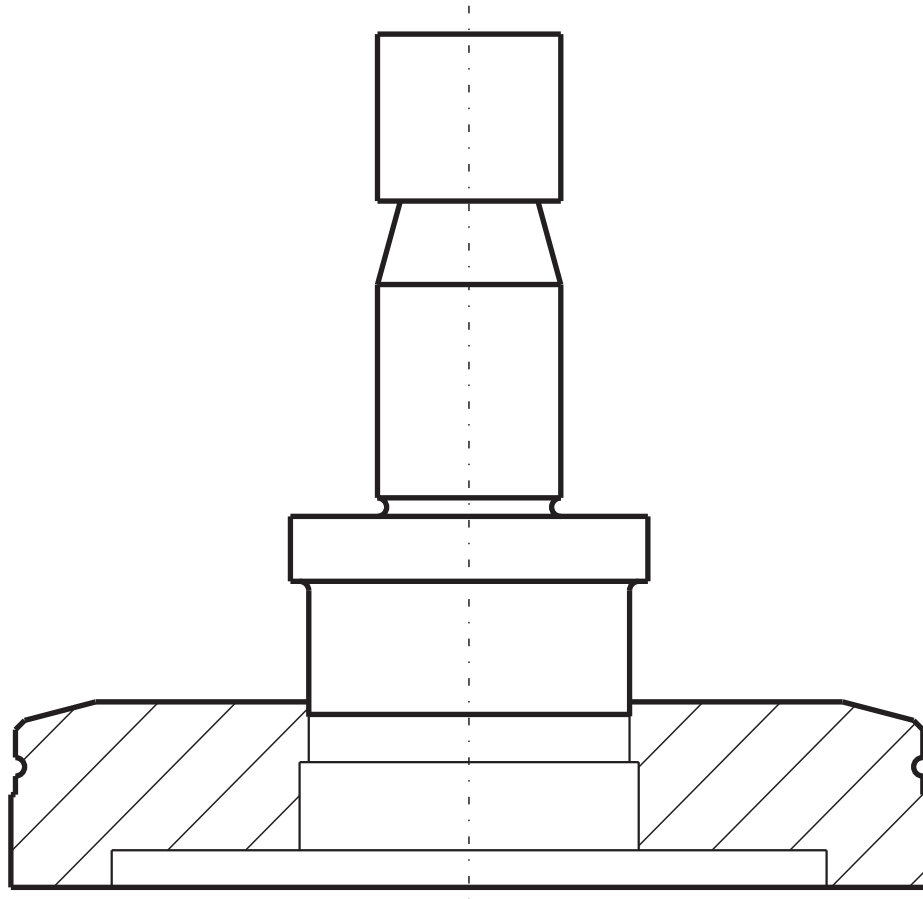

We recommend a punching depth of 1 - 2 mm into the die.

**Attention! With wrong submergence slug pulling can develop!**

## 7 The maximum punching diameter

description	pieces	max. punch Ø
standard tooling	1	105 mm
Revotool 4 way	4	25 mm
Revotool 6 way	6	20 mm
Revotool 7 way	6	16 mm
	1	30 x 5 mm
Revotool 8 way	8	16 mm

The diagonal A; for round -, square -, rectangle- and obround hole tools; please infer from the chapter „ 5.1 calculation tool extent“, in this manual.

### 7.1 Calculation of the maximum punching diameter

The range „d“ becomes by that max. diameter (circle envelope) as a function of the tool center determines.

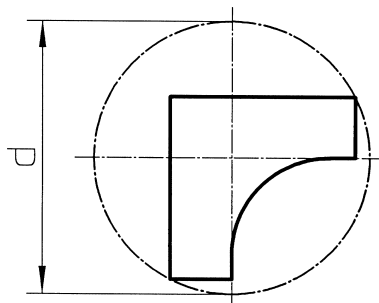

## 8 Service life increase

### 8.1 Optimization of the steel grade and/or the degree of hardness from the tools

Optimization of the steel grade and/or the degree of hardness from the tools by breaking of tools and/or breaking out of tools at the cutting edges due to high cutting forces (with treatment of thicker and/or high-strength sheet metals). With the HSS- quality (highly alloyed high-speed steel) generally best results are obtained. However sometimes in the case of extreme demand of the firmness of the tools higher service lives can be achieved by appropriate coatings and/or surface treatments.

### 8.2 Titanium nitride (TIN)/Titanicarbonitrid (TICN) coated tools

With premature wear of the cutting edges and/or profile surfaces due to treatment of abrasiver materials as well as breaking of tools due to high pull-back powers (in processing of materials, which bend like ST37 and Nirosa to cold shuts). Hardness of the titanium layer 2400 HV, hardness TICN of the layer 3000 HV, layer strength 3.

Coated tools can achieve extremely high service lives, scales, etc. (superficial or in the form of inclusions) but they are however sensitive and become useless with the breaking of the layer in relation to contamination of the processing sheet metals with sand sharpening of coated tools is possible.

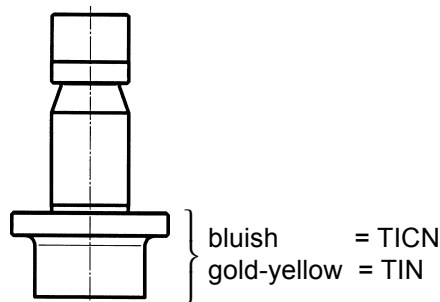

### 8.3 Titanium nitride (TIN) coating

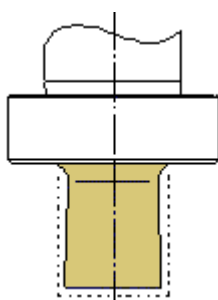

The titanium nitride (TIN) coating will be particularly recommend for the treatment of aluminum. This coating emphasizes itself by the golden surface clearly. The hardness of the titanium nitride layer amounts to 2,400 HV. The layer strength amounts to approx. 3  $\mu$ .

## 8.4 Titancarbonitrid (TICN) coating

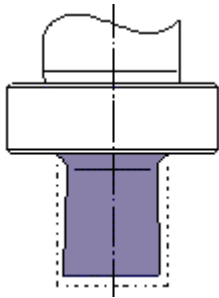

The titanium nitride (TIN) coating will be particularly recommend for the treatment of steel and high-grade steel. The TICN coating one shows violet to bluish colouring, is not as strongly remarkable as the TIN- covering. However the hardness TICN of the cover is with 3.000 HV. The layer strength amounts to approx.. 3  $\mu$ .

## 8.5 Using of suitable coolant and lubricants

We recommend you for the optimal cooling and lubrication:

Emulgan D  
Mixing ratio 1/10

order - no.: 30110042

## 8.6 Relief produced by grinding of punches

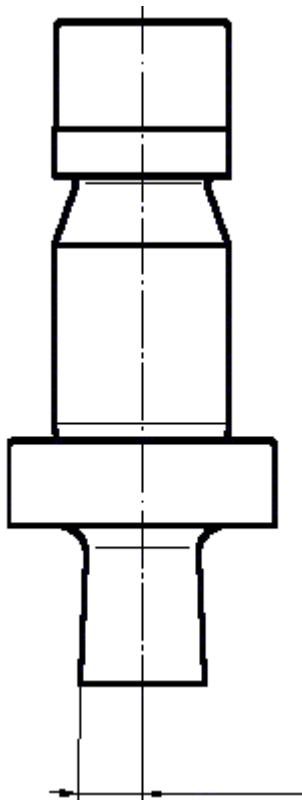

We produce our standard toolings always with relief part.

Particulary by working with VA sheet metal or thick sheet metal can be a relief part very important to reduce the adhaesive wear and to avoid the outbreak of the corners.



## 8.7 Corner radius with punches

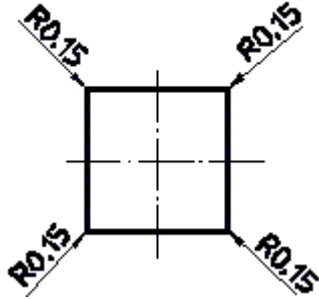

A general service life problem is the corner wear on e.g. square and triangle punches.

### Standard:

To reduce the wear of the corner we generally sharpen a corner radius of  $R = 0.15$  mm on every punch.

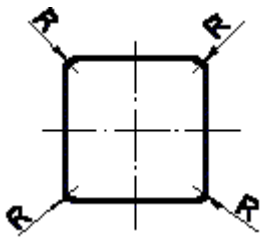

By working on e.g. VA sheet metals is it advisable to increase these corners radii (e.g.  $R = 0.5$  and/or as largely as possible).

## 8.8 Punch with whisper

1. Punches with whisper will be set in for fullcut to a thickness of 10 mm.
2. Punches with whisper do have a slope of  $50^\circ$  in their outside diameter  $D=10,51$  mm to 35 mm, from diameter 35 mm a constant measure of altitude of 3 mm. That means that the helix angle depends from the outside diameter.
3. Punches with whisper do have a diagonal cut edge up to outside diameter  $D=72$  mm, from  $D=72$  mm on (size III) a V- form double slope. Simply regrind is guaranteed.
4. Flat punches for machine group A-H do have a length of 74mm, for machine group I 77,5mm. Punches with whisper have fundamental a total length of 77 mm.
5. An additional silencing from 3-5 dB by sheets to  $s=3$  mm can be produced if you use PU-strippers. This ones are insertable for punches up to diameter 48 mm.
6. By calculating of the max. punching diameter you have to use the maximum power schedule respectively with the included shearing factor in the machine operating manual.
7. Obtainable constructions fo punches with whisper will be shown on the following page.

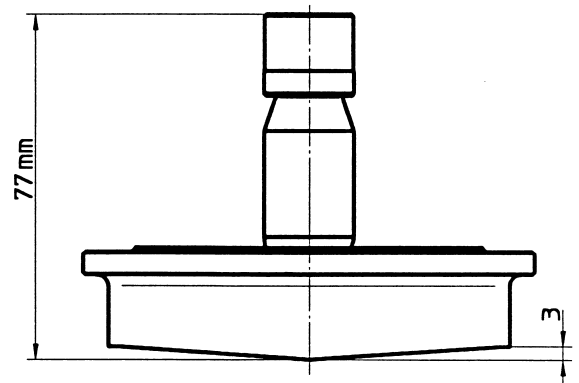
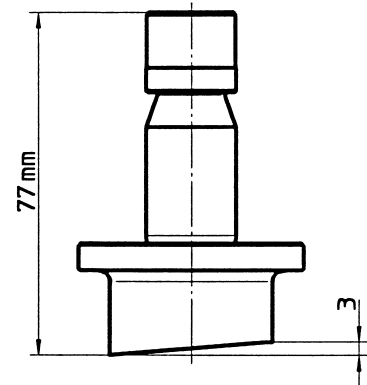
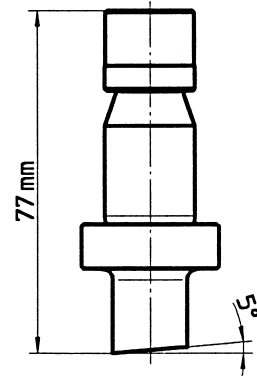

## 8.9 Obtainable constructions of punches with whisper

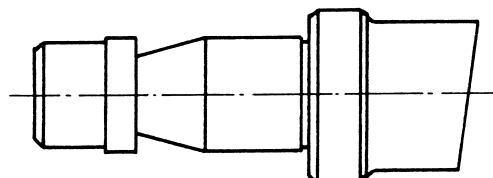
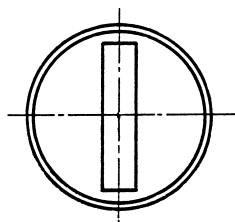

WT

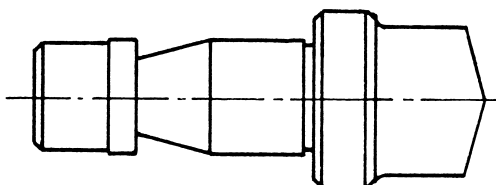
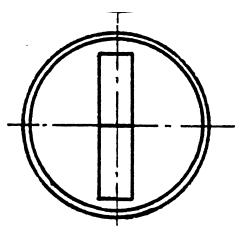

DOWT

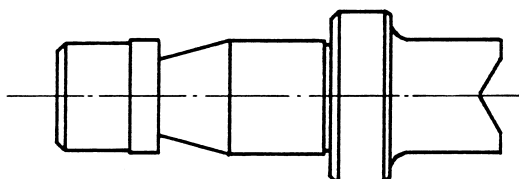
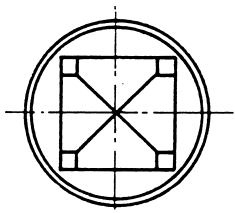

4PT

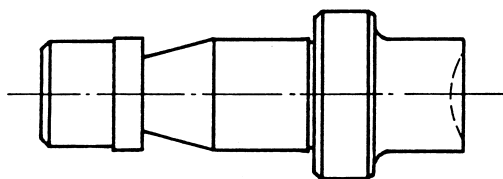
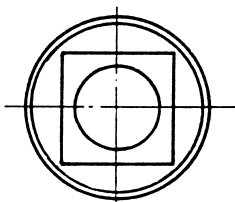

K for nibbling

## 9 Heavy duty tooling

### 9.1 Using of tools reinforced version

Example: Revotool

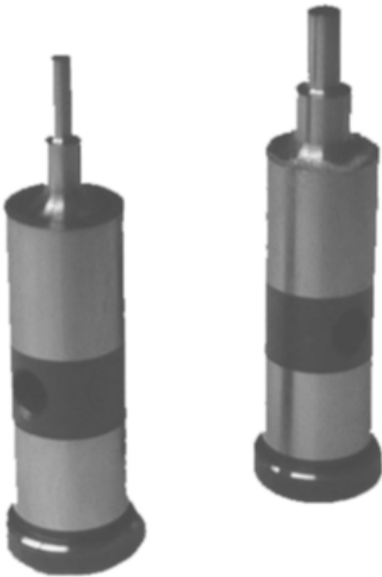

Strengthened execution



Standard execution

These punches are recommend espacially for sheet thickness wich are not as thick as the diameter or the width of the punch.

Generally it applies by using of mild steel that the punch should not be less than the plate thickness. By using of high-grade steel is the amount one and a half of the plate thickness.

## 9.2 Punching tools “reinforced version” / heavy duty tools



Please always compute the punching strength before you start with the treatment. Those max. punching force of the punching machine can be easily overrated.

## 9.3 Heavy duty punch

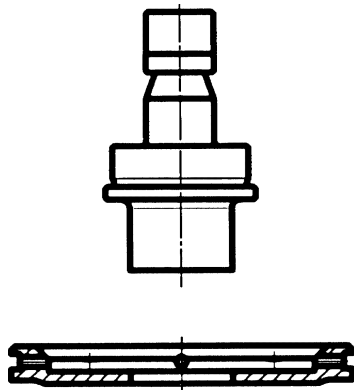

The tools “reinforced version” are particularly suitable for high-die materials and thick sheet-steel plates. To kept develop as high service life and a life span as possible.

- use of heavy duty adjusting rings
- use of steel strippers
- min. sheet thickness of 10.0 mm and more, and/or if the necessary punching die mind. 200 kN amounts to.
- min. punchØ diameter 10.0 mm
- max. punchØ diameter 76.2 mm

## 9.4 Heavy duty adjusting ring included wedge strengthened form

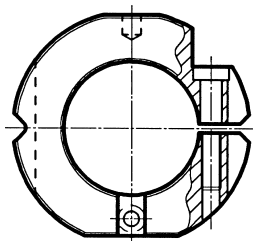

## 9.5 Heavy duty dies

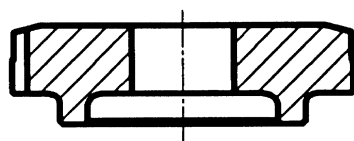

The thickness of the die is increased by the strengthened lower federation.

- starting from 200 KN punching strength or
- to max. die Ø 60.0 mm

## 10 Machines with rotation

The initial costs of the tools and readjusting time has become clearly less.

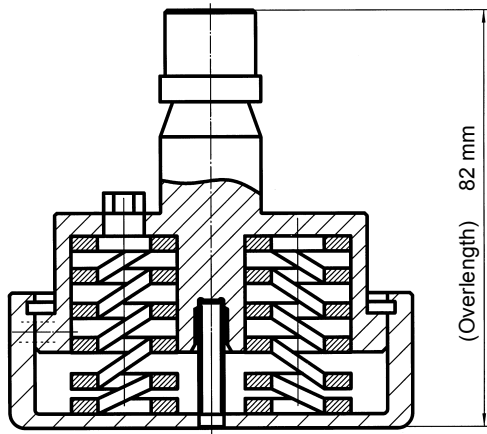

We recommend our particularly developed slitting tool with active stripper system for punching machines with rotation.

### Special advantage:

- small safety area
- changeable knife

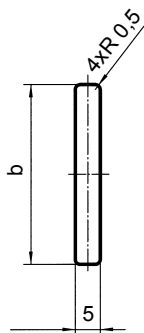

**Attention**  
 extended tooling ➡ observe the depth of immersion

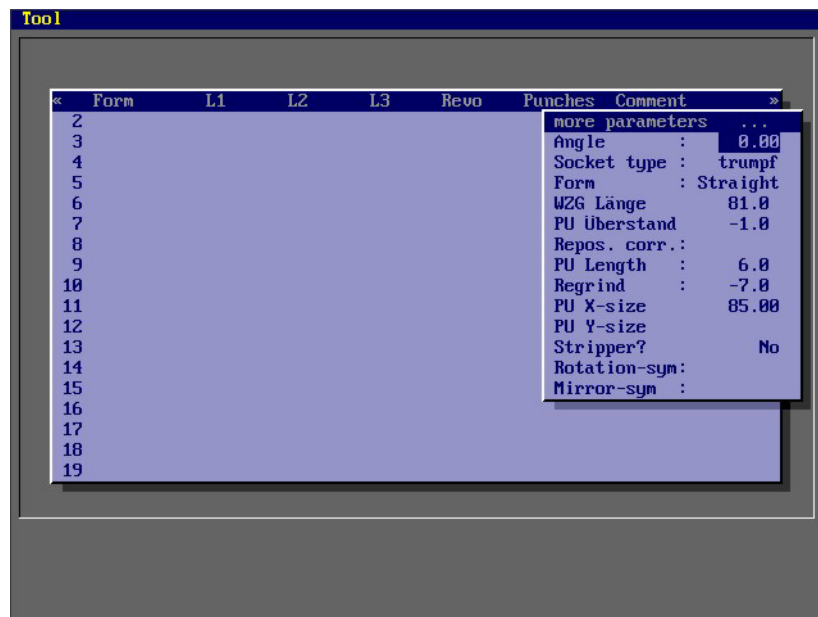

## 10.1 Using of multiple radius tools

Multiple radius tools prevent additional processing steps (also possibly on another machine). The rotation punching machine becomes more effectively used and the complete costs of toolings becomes more reduced.

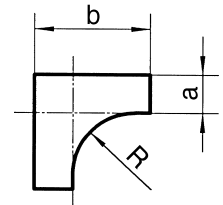
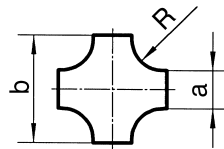
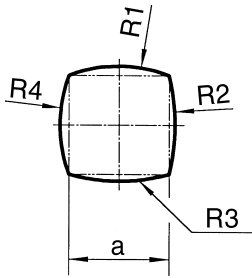

## 11 Tool dimensions

### 11.1 Punch chuck with insert size 0 (0-6,0) and (6,01-10,5):

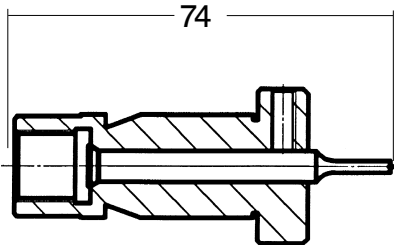

punch length = 74,0 mm  
 Max. regrinding length = 3,0 mm

### 11.2 Punch revotool

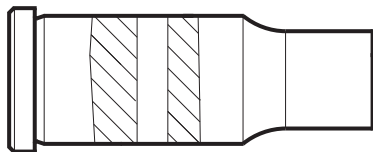

Typ	punch length	max. Ø	g t h *
4- ways	71 mm	25 mm	2 mm
6- ways	71 mm	20 mm	2 mm
7- ways	71 mm	16 mm	2 mm
8- ways	71 mm	16 mm	2 mm

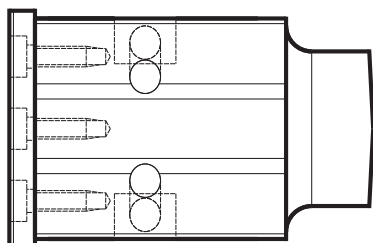

Typ	punch length	max. regrinding length*
7- ways Sliding punch	71 mm	2 mm

\* The instruction that max. regrinding length is only recommendations!



## 11.3 Die revotool

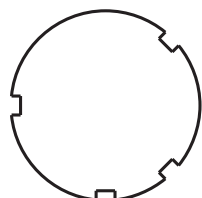

Type	Die height	Max. Outside Ø	max. regrinding length*
4- ways	20 mm	40 mm	1 mm
6- ways	15 mm	30 mm	1 mm
7- ways	15 mm	15 mm	1 mm
8- ways	15 mm	25 mm	1 mm

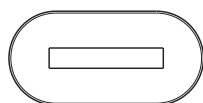

Type	Die height	Max. Outside Ø	max. regrinding length*
7- ways Sliding die	15 mm	51 mm	1 mm

\* The instruction that max. regrinding length is only recommendations!



**min. die cl. 0.2 mm**

## 11.4 Punch size 1, 2 and 3 flat:

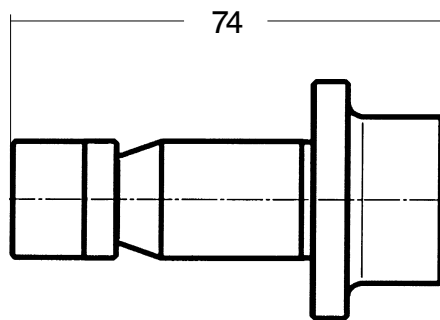

punch length = 74,0 mm  
Max. regrinding length \* = 10,0 mm

\* The max. regrinding length depends on the material thickness which can be punched!  
The instruction that max. regrinding length is only a recommendation!

## 11.5 Punch size 1, 2 and 3 whisper:

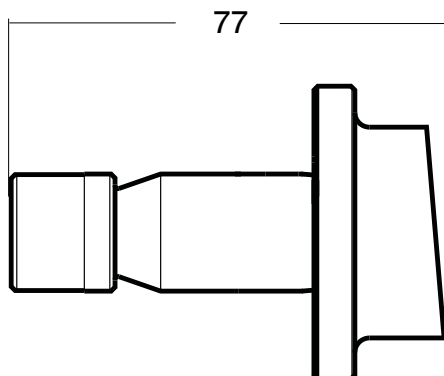

punch length = 77,0 mm  
Max. regrinding length \* = 10,0 mm

\* The max. regrinding length depends on the material thickness which can be punched!  
The instruction that max. regrinding length is only a recommendation!

## Valid for all stamps:

After regrinding, please the stamp length in the tool list of your punching machine under reground corrects.

We recommend after sharpen the stencils to bring the overall height by spacers on the output measure. Prices and delivery time take you please from our price list.

## 11.6 Die size 1:

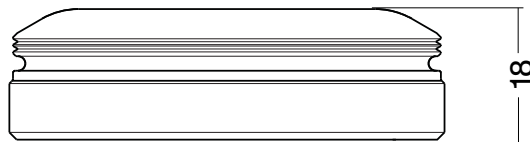

Die height = 18,0 mm

max. regrinding length = 1,0 mm

## 11.7 Die size 2:

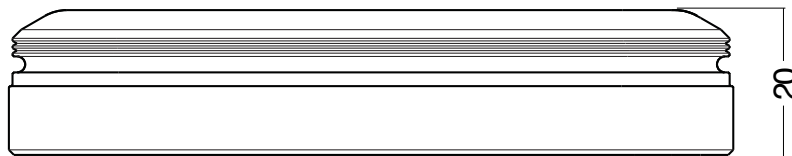

Die height = 20,0 mm

max. regrinding length = 1,0 mm

## 11.8 Die size 3:

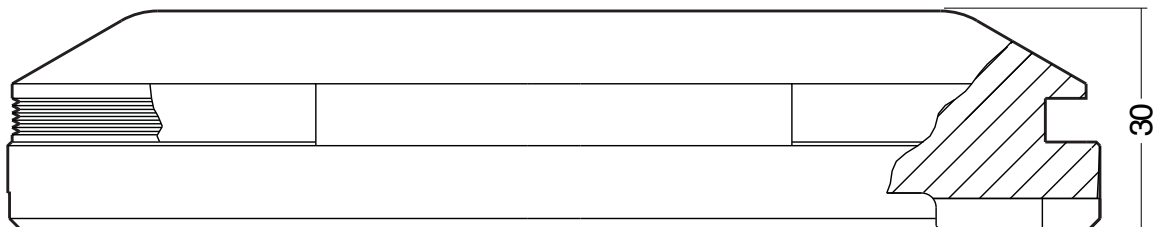

Die height = 30,0 mm

max. regrinding length = 1,0 mm

\* The instruction that max. regrinding length is only recommendations!

## 12 Form position

### 12.1 Definition of the form position from a punching in the sheet metal

Definition of the L. Boschert standard slot situations with stencils size I, II and III for all machine types.

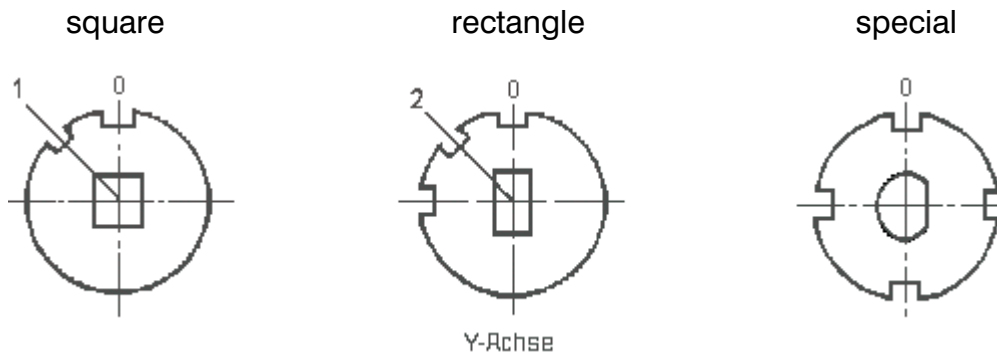

For special slots the angle of the 0°- Position is out indicated.

### 12.2 Standard using for dies size III system Boschert

Standard slots		
round	square	rectangle/ obround
0°	0°, 45°	0°, 45°, 90°

Additional slots against surcharge available.

## 13 Providing a punching tool

For details on the tools system (sizes, forms, etc.) please see our separate „Punching tools“ brochure.

**Always work with an adjustment ring. It conveys the punching forces that develop onto the cap of the ram which was designed for this purpose.**

Tools with  $\varnothing$  up to 30 mm have an adjustment ring with a collar.

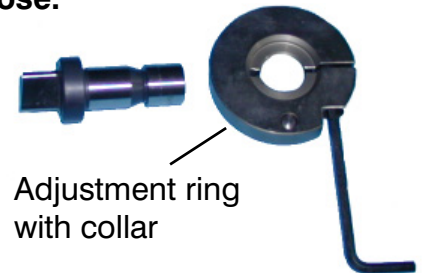

Adjustment ring with collar

Tools with  $\varnothing$  from 30 to 105 mm have an adjustment ring without a collar.

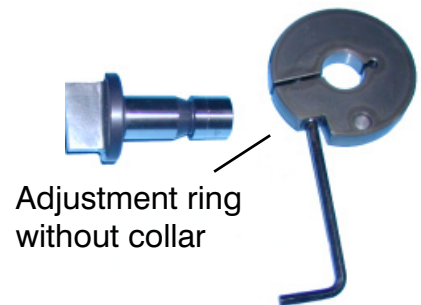

Adjustment ring without collar

### Punching needle of $\varnothing$ 6.0 or $\varnothing$ 10.5 mm:

- insert punching needle into punch chuck,
- screw threaded piece into punch chuck and **tighten fast**, (do not tighten too much since otherwise the punch chuck could get deformed or destroyed during punching action),
- control measure: punch until end of punch chuck = 74 mm,
- secure the punching needle by means of the headless screw (in case of forming tools),
- push adjustment ring on the punch chuck and align the punch in the adjustment appliance (only forming tools, see point 14.1, adjustment process),
- clamp adjustment ring by means of the M6 screw,
- push polyurethane stripper (PU) on the punching,
- projecting PU / cutting edge min 1 mm.

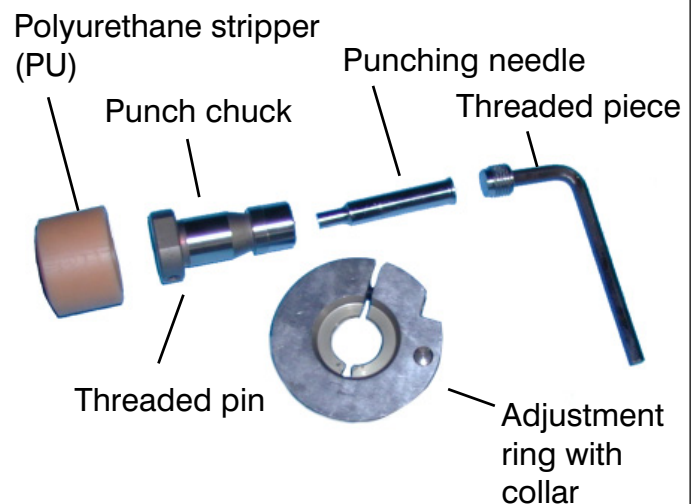

## Special feature of the PU- stripper

### Punches with Ø of 1,5 to Ø 30 mm (size I):

- push adjustment ring on the punch and align in the adjustment appliance (only forming tools,
- clamp adjustment ring by means of the M6 screw,
- push Polyurethane stripper (PU) on the punching needle until it reaches the collar of the punch chuck,
- projecting PU/ cutting edge mind. 1mm.

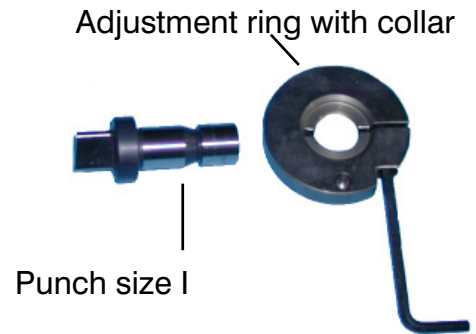

### Punches with Ø of 30 to Ø 76,2 mm (size II) and punches with Ø of 76,2 to Ø 105 mm (size III):

- Same procedure as with punch size I, however without collar on the adjustment ring.

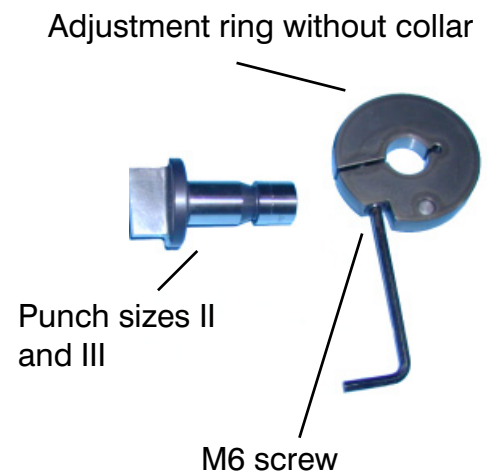

## 13.1 Special features of the polyurethane stripper (PU)



Attention

- Mounting the PU stripper and making the start hole is performed in one work step where punch and die are mounted. Place the PU stripper centrally on the die and punch the start hole. By pressing two-hand operation in the manual operation mode.
- The PU stripper will rest on the tool or adjustment ring depending on the size of the tool.
- If the PU stripper rests on the adjustment ring then the adjustment ring should not be dismantled after. However if it will be dismantled then the PU stripper must be pushed downward by at least 5 mm in order to ensure that the adjustment ring rests accurately (the PU stripper extends upwards when the adjustment ring is removed).
- For forming tools, the PU stripper must be dismantled completely since adjustment is possible only via the cutting edges.

## 13.2 Adjusting a forming tool

For **round punches**, the adjustment ring is mounted independent of the position.

For **forming punches**, the adjustment ring must be mounted with positional accuracy by means of the adjustment appliance.

Pay attention to the following:

- the mirror-image position of the punch in the appliance,
- the position of the cam (2) in the accommodation of the tool.

### Adjusting procedure:

- \* unscrew the screw (3),
- \* select groove for desired angle,
- \* insert punch spigot (4) into adjustment appliance,
- \* insert cam (2) into selected groove,
- \* release clamping lever (5),
- \* push stop (6) towards the punch, (so that the punchesurface is adjacent to the edge (6a)),
- \* tighten clamping lever (5),
- \* tighten screw (3),
- \* release clamping lever (5),
- \* take off the punch.

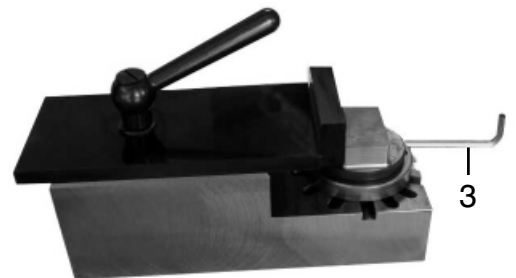
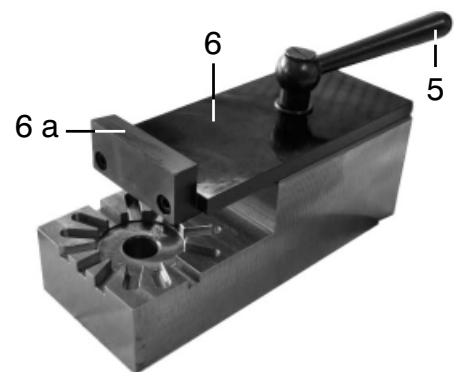
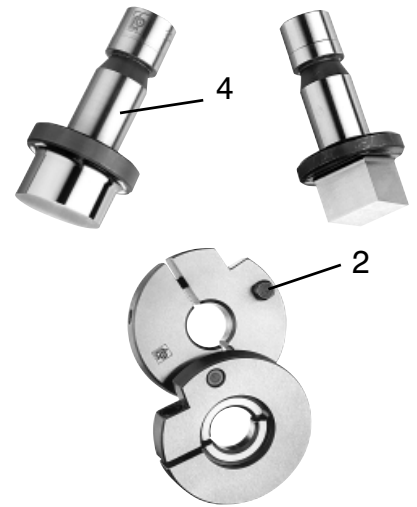

### Check:

**The adjusting ring must lie axially on the bearing surface of the punch (control measure 40 mm).**

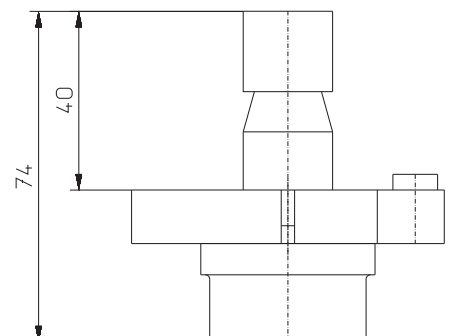

## 13.3 Stripper

You have two possibilities to take off the material:

**stripper** (steel) and **active stripper** (with feather or plastic PU)

## 13.4 PU- stripper

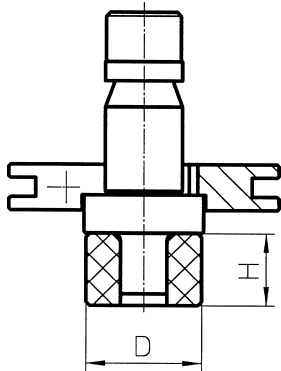

- Advantages:
- Active stripping
  - Silencing
  - Rapid changing of the tools cause the PU- stripper is directly on the punch.
  - small safety zone of the clamps
  - favourable price

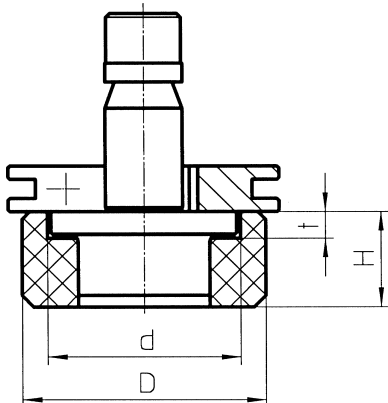

- Disadvantages:
- The PU- stripper is most suitable for material thickness more than 4 mm and diameter more than 50 mm.

## 13.5 Metall- stripper

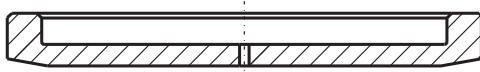

- Advantages:
- To be recommended for material more than 3 mm.



## 13.6 Tool change with PU - stripper; punch Ø 10,5 - Ø 30mm

punch holder in punch head

punch adjustment ring

punch Ø 10,5 mm or bigger than Ø 10,5 mm

PU stripper;  
punch with overhang  
approx. 1 mm

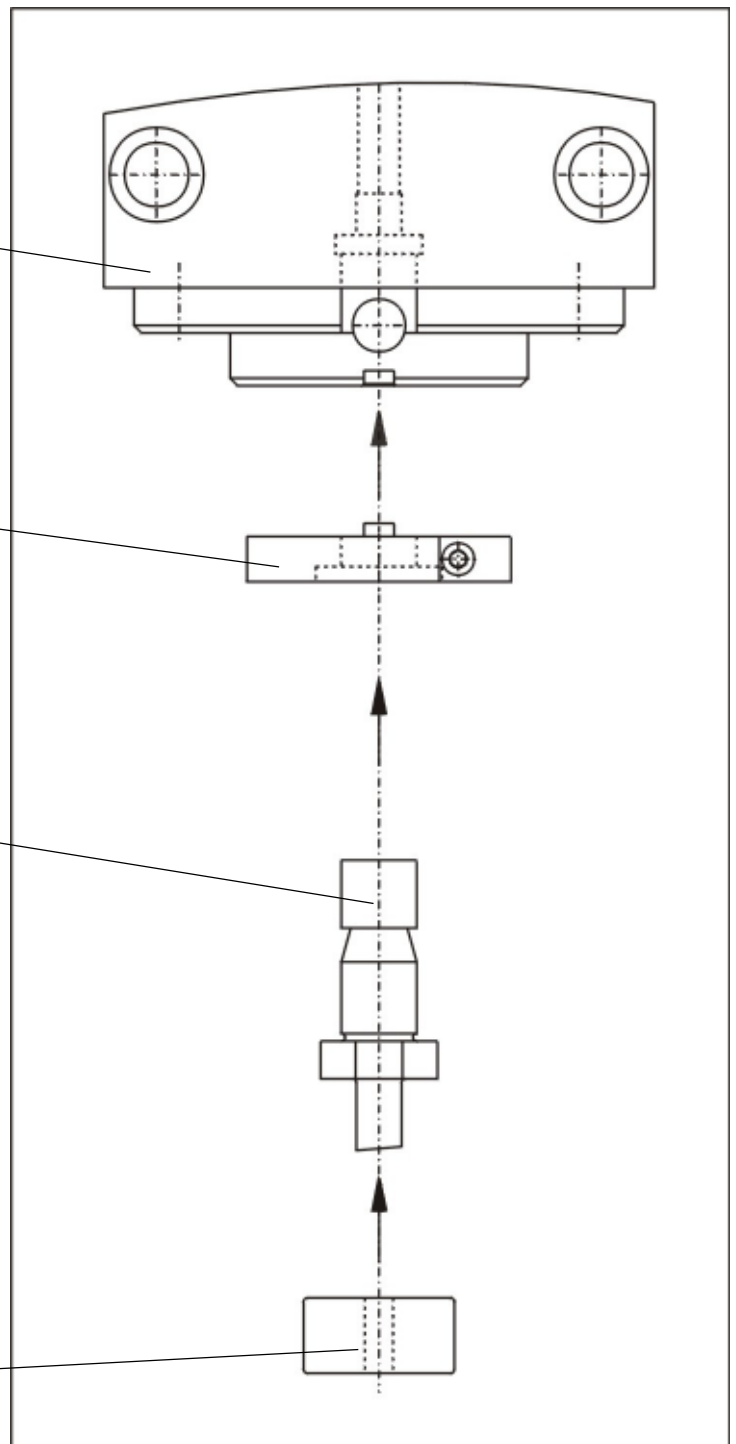

## 14.1 General information about the Revotool

### To enter the punch in the punch holder:

1. By turning of the set collar you can bring it in the right position
2. Enter punch in the hole of the holder
3. Put in the pin (because of this is the punch fixed)
4. Protect the locking piston by turning of the set collar

### To remove the punch in the punch holder:

1. By turning of the set collar you can bring it in the right position
2. Remove the pin (because of this the fixation of the punch will be removed)
3. Put out the punch

### Standard slot in the dies:

0°, 45° or 90° (for round shapes only 0 degree)

### The position of a rectangle punch and die with the help of an example:

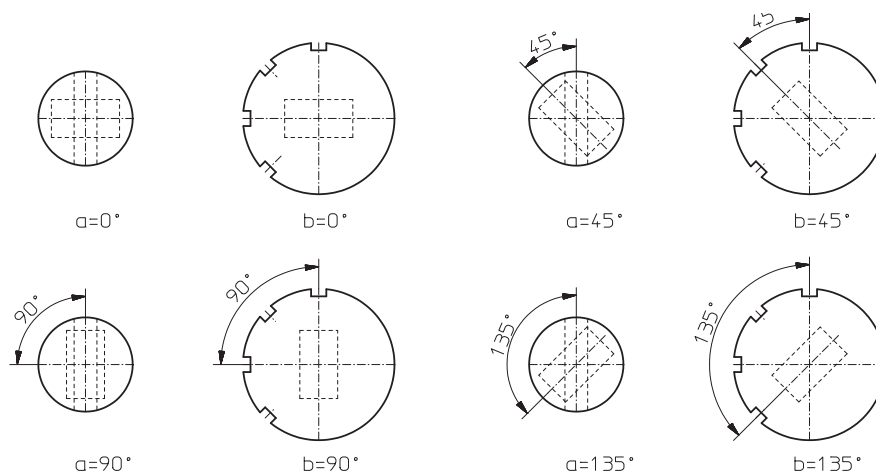

### If you place an order please pay attention for the following:

- \* Please order 6 weeks before delivery of the machine
- \* Mark the position of the punch on the sheet within
- \* Fax it to company L. Boschert with no. +49 7621/55184

## 14.2 Informations about revotool punch and die holder

### 4- way / 6 mm & INDEX

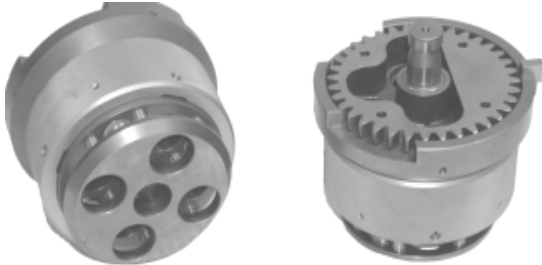

- punch: max. diam. 25mm
- position of standard form punches: 0° and 90° through changing the position.
- 45° must be declared by you if you place an order
- produced since 2000

### 6 – way / 6 mm & INDEX

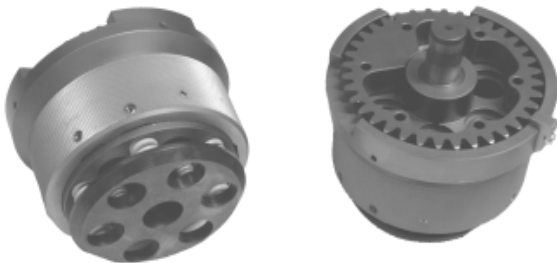

- punch: max diam. 20 mm
- position of standard form punches: at the sliding 0°
- position no and degree has to be declared by placing an order
- produced since 2000

### 7- way / 6 mm INDEX



- 6 punch: max. diam. 16 mm
- 1 slitting blade 30 x 5 mm
- only for Index-rotation machine!
- produced since 2000

### 8- way/ 6 mm & INDEX

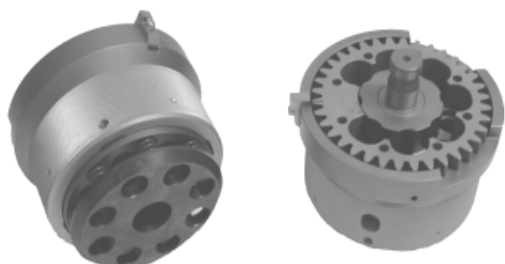

- punch: max. diam. 16mm
- position of standard form punches: possibility to change the angle through changing of the position (0, 45 or 90 degree)
- produced since 2000

### 14.3 Special stripper for thin material thickness < 1mm

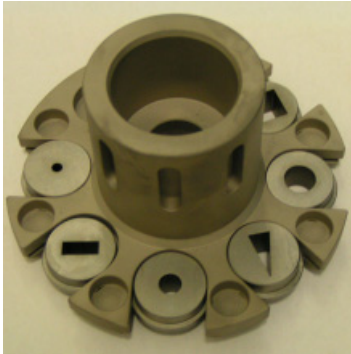

Thin sheet stripper with inserts prevents that the material will be raised with the punch during the punching process. Because of this will be a clear result guaranteed.

You have to order for every punch the suitable insert.

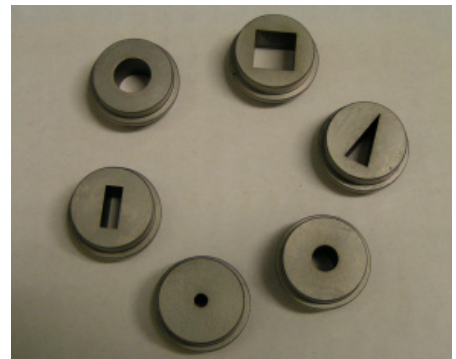

## 14.4 In that way you won't damage your tools unnecessary by working of borders

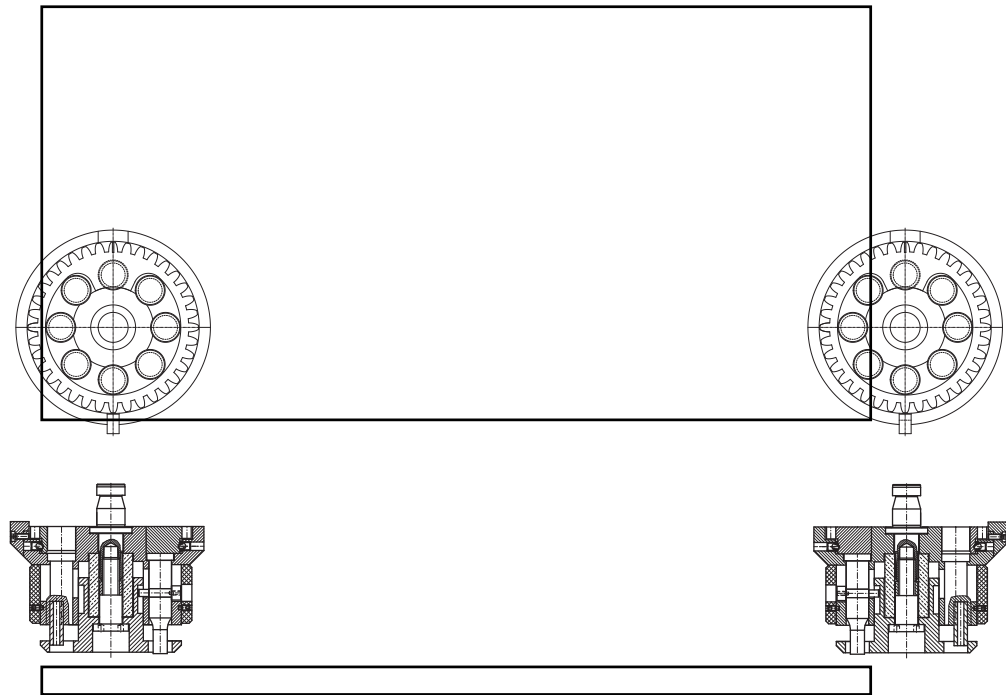

right

wrong

By working off from sheets be paid attention that you do not overload the Revotool by working of edges. Especially by working off from thicker sheets (2,5 - 6,0 mm).

As you will see on the drawing should be the tooling with the whole surface supported on the workpiece (for example: corner notchers, notcherson 4 corners.

Should it be required that the workpiece have at the right and left side or at the top or bottom side the same punching, please put two times the same punch parallel in the tooling.

**Take care** on a proper handling so that it will be guaranted to have a long service life.

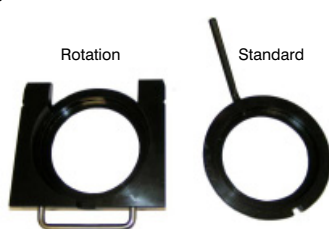

If you work with thicker material (2,5-6mm) you have to use an additional steel stripper because the power of the feather from the Revotool is not enough. The punch could get stuck in the material and be damaged or destroyed.

**Note that we refuse the guarantee if you do not observe this rules.**

## 14.5 Maintenance

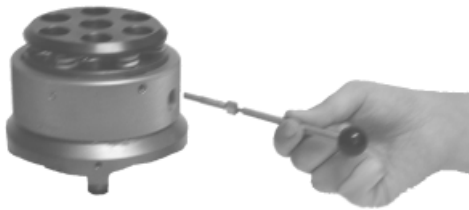

1. Take out the locking pin by using the threaded rod
2. Take out all punches



3. Fix the punch holder in a fixing device



4. Open the stripper peg with the gripping tool and take them together with the ring out.

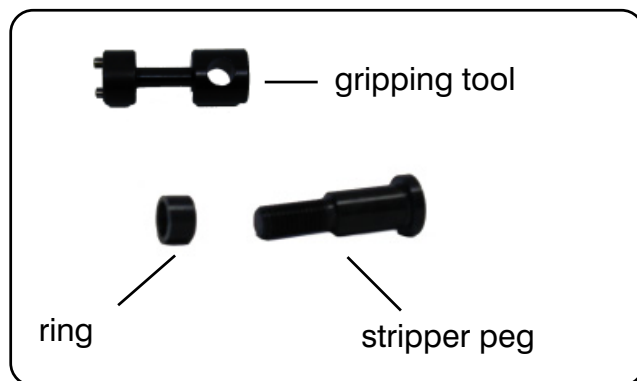

5. Grease the stripper shaft

**Clean and grease the Revotool after approx. 50.000 strokes and if required please change the feathers.**



**You have to change the feathers of the Revotool absolutely after approx. 100.000 strokes.**



6. Insert the stripper to the correct position

7. Stick in the stripper peg



8. Enter the ring and stripper peg and tighten them with the gripping tool

**Attention! You have to put in the locking piston, after insertion of the punch and protect it by turning of the set collar.**



**You have to test the stripper peg after every using to solid seat.**

**Problems:**

**The locking piston breaks, see chapter 18 - problem solutions.**

## 14.6 Spare parts

Specification	Order no.
Revotool 4- way / 6mm set springs (4x Ø18,2 x 38 mm / 12x Ø8,5 x 38 mm / 4x Ø9,6 x 38 mm)	60006066
Revotool 6- way / 6mm set springs (6x Ø9,6 x 38,7 mm / 6x Ø15,5 x 38,3 mm)	60006058
Revotool 7- way / 6mm set springs (8x Ø11,9 x 44,6 mm / 1x Ø31,3 x 51,6 mm)	30006098
Revotool 8- way / 6mm set springs (8x Ø11,9 x 44,6 mm / 1x Ø31,3 x 51,6 mm)	30006050
grease top 2000	30006074



# Example Order sheet

## Revotool 6 - way / 6 mm



Customer: Company Mustermann  
 Order-No.: AK 241

Customer No.: 141112  
 deliver time: KW 04

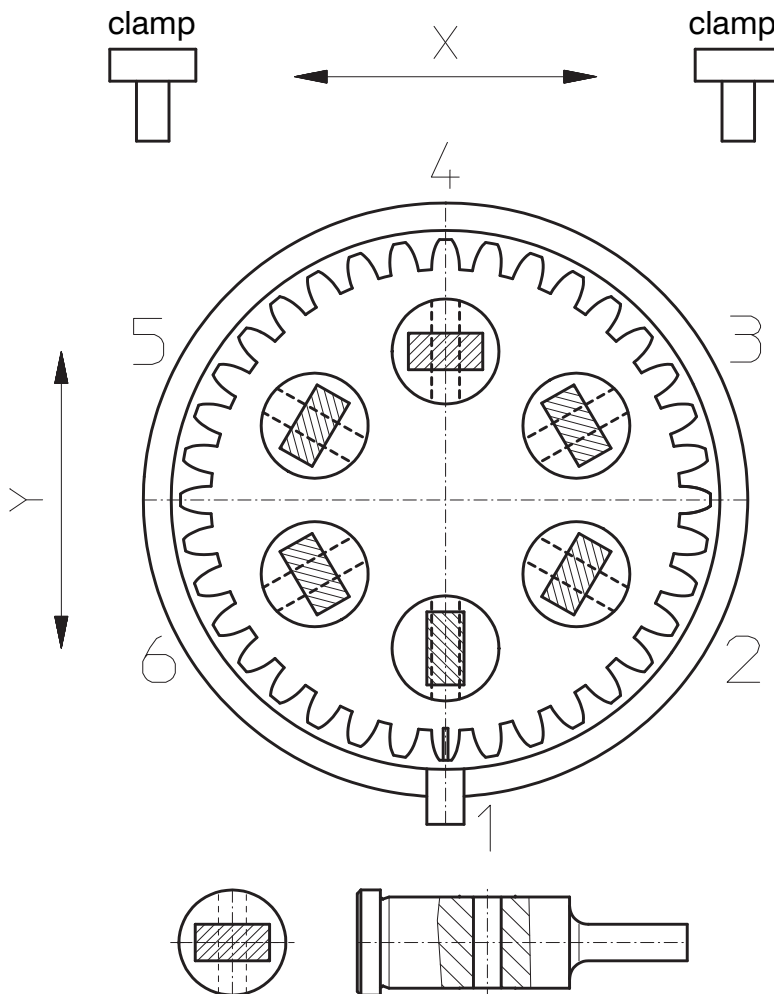

Please make your drawing into this place for the special tooling:

punch: max. diam. Ø: 20 mm

31230001

Qty.	Shape					Punch size	Die size	Pos. no.	Position in °
	○	□	▭	◌	special				
1			×			5,0 x 18,0	5,3 x 18,3	1	0°
1					×	H=15 A=45°	die clearance 0,3 mm	2	45°
1			×			5,0 x 18,0	5,3 x 18,3	3	90°
1	×					18,0	18,3	4	0°
1				×		4,0 x 20,0	4,3 x 20,3	5	90°
1		×				14,0 x 14,0	14,3 x 14,3	6	45°

Date: 04-12-2003

Signature: U. Mustermann

Mattenstraße 1  
 79541 Lörrach-Hauingen

infoak@boschert.de  
 www.boschert.de

Tel.: +49 (0) 7621 - 95 93 0  
 Fax: +49 (0) 7621 - 55 18 4

41

# Order sheet

## Revotool 4 - way / 6 mm



Customer: \_\_\_\_\_ Customer No.: \_\_\_\_\_  
 Order-No.: \_\_\_\_\_ deliver time: \_\_\_\_\_

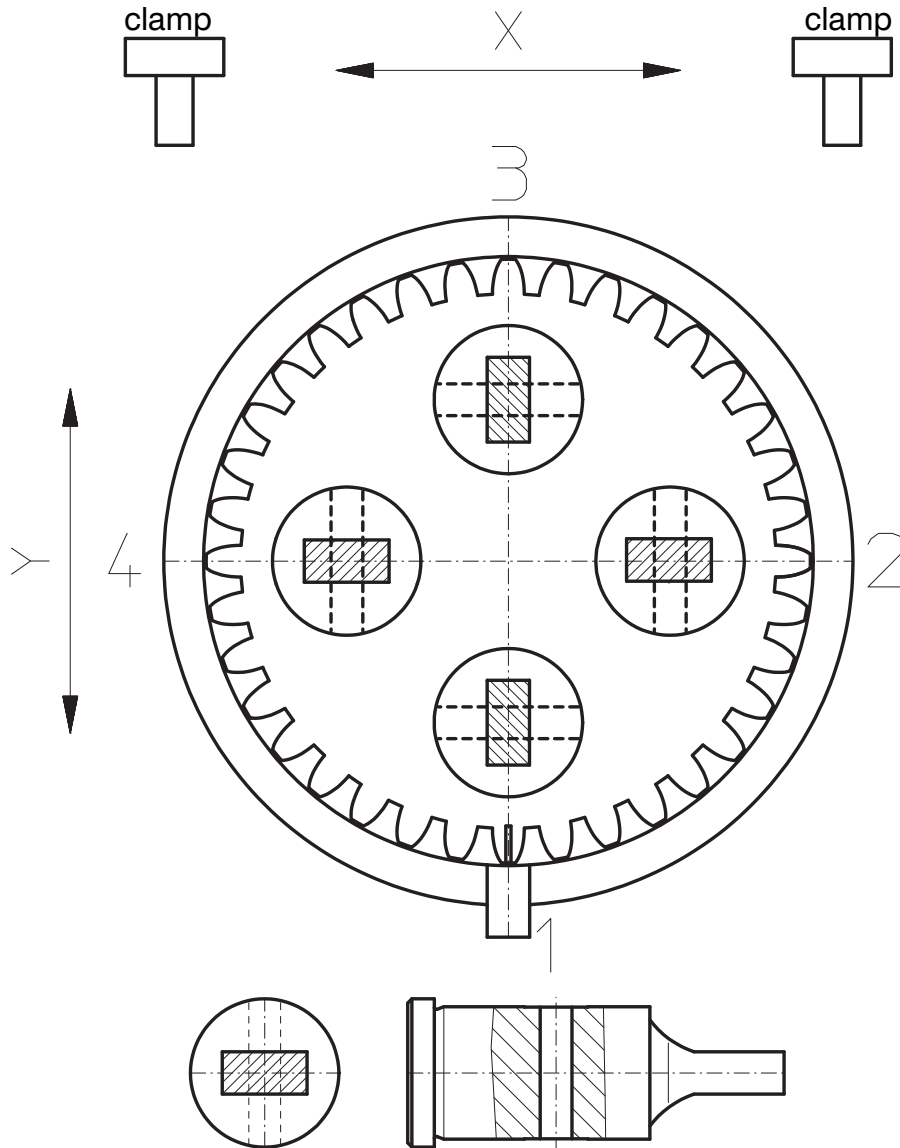

Please make drawing into this place for your special tooling:

punch: max. diam. Ø: 25 mm

31230001

Qty.	Shape					Punch size	Die size	Pos. no.	Position in °
	○	□	▭	◌	special				

Date: \_\_\_\_\_ Signature: \_\_\_\_\_

Mattenstraße 1  
79541 Lörrach-Hauingen

infoak@boschert.de  
www.boschert.de

Tel.: +49 (0) 7621 - 95 93 0  
Fax: +49 (0) 7621 - 55 18 4

42

# Order sheet

## Revotool 6 - way / 6 mm



Customer: \_\_\_\_\_ Customer No.: \_\_\_\_\_  
 Order-No.: \_\_\_\_\_ deliver time: \_\_\_\_\_

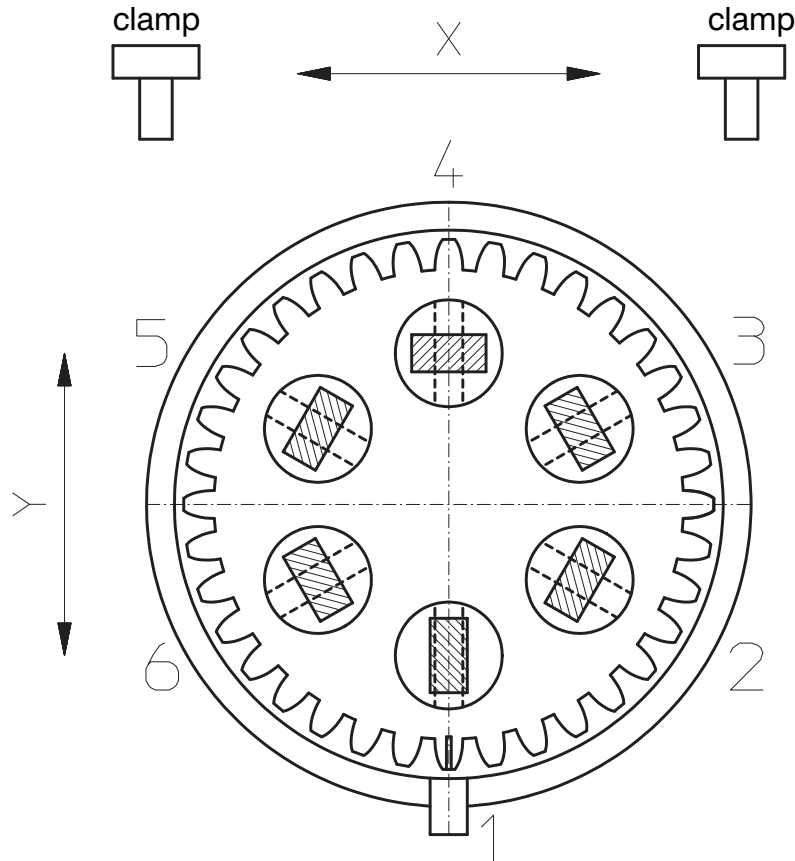

Please make your drawing into this place for the special tooling:

punch: max. diam. Ø: 20 mm

31230001

Qty.	Shape					Punch size	Die size	Pos. no.	Position in °
	○	□	▭	◌	special				

Date: \_\_\_\_\_ Signature: \_\_\_\_\_

# Order sheet

## Revotool 7 - way / 6 mm



Customer: \_\_\_\_\_  
Order-No.: \_\_\_\_\_

Customer No.: \_\_\_\_\_  
deliver time: \_\_\_\_\_

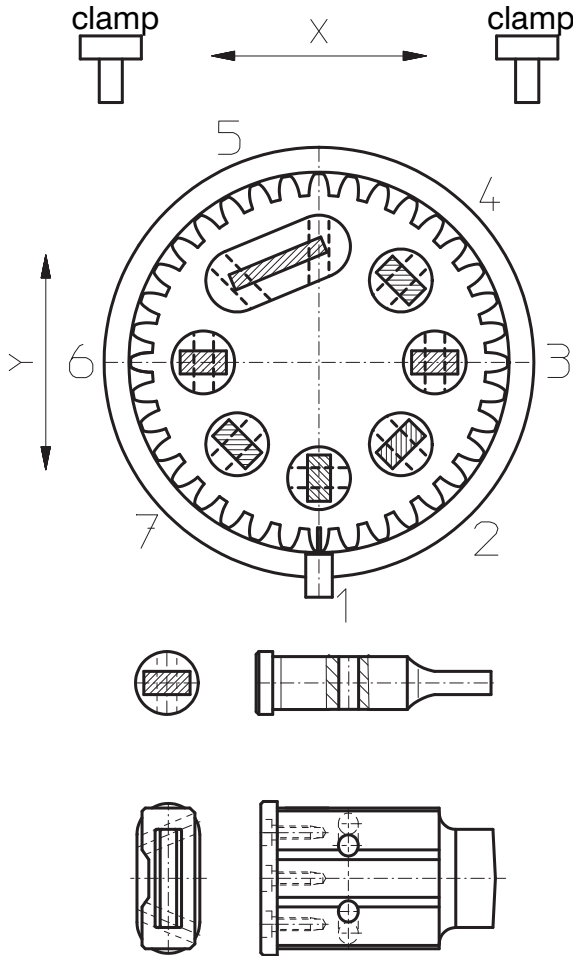

Please make your drawing into this place for the special tooling:

6 x punch: max. diam. 16 mm

31230001

Qty.	Shape					Punch size	Die size	Pos. no.	Position in °
	○	□	▭	◌	special				

Date: \_\_\_\_\_

Signature: \_\_\_\_\_

Mattenstraße 1  
79541 Lörrach-Hauingen

infoak@boschert.de  
www.boschert.de

Tel.: +49 (0) 7621 - 95 93 0  
Fax: +49 (0) 7621 - 55 18 4

# Order sheet

## Revotool 8 - way / 6 mm



Customer: \_\_\_\_\_  
 Order-No.: \_\_\_\_\_

Customer No.: \_\_\_\_\_  
 deliver time: \_\_\_\_\_

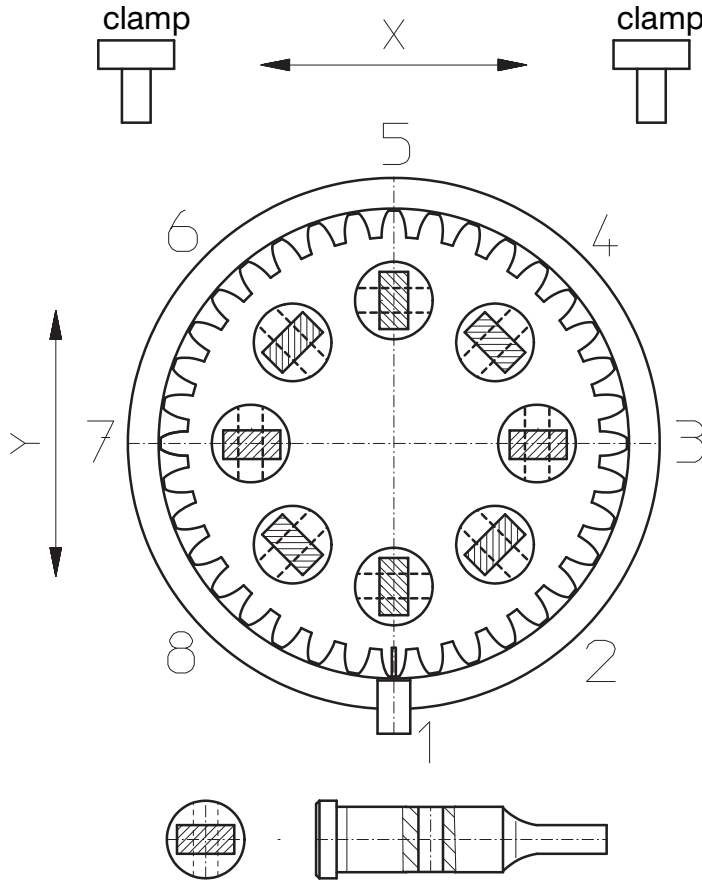

Please make your drawing into this place for the special tooling:

punch: max. diam.Ø: 16 mm

31230001

Qty.	Shape					Punch size	Die size	Pos. No.	Position in °
	○	□	▭	◌	special				

Date: \_\_\_\_\_

Signature: \_\_\_\_\_

Mattenstraße 1  
 79541 Lörrach-Hauingen

infoak@boschert.de  
 www.boschert.de

Tel.: +49 (0) 7621 - 95 93 0  
 Fax: +49 (0) 7621 - 55 18 4

## 15.1 Spare part Revotool 4- way / 6 mm

31203008a

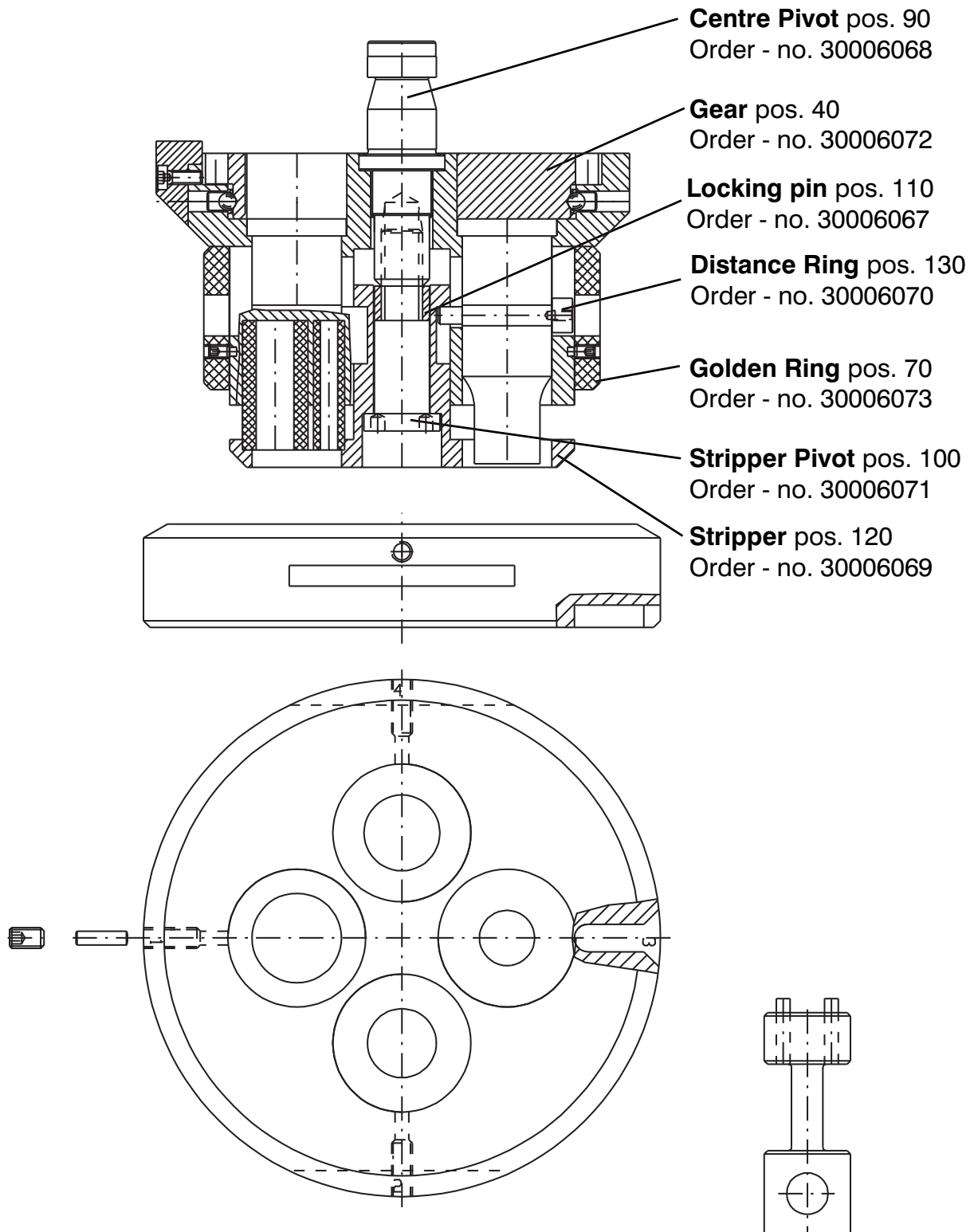

## 15.2 Spare part Revotool 6- way / 6 mm

31203009a

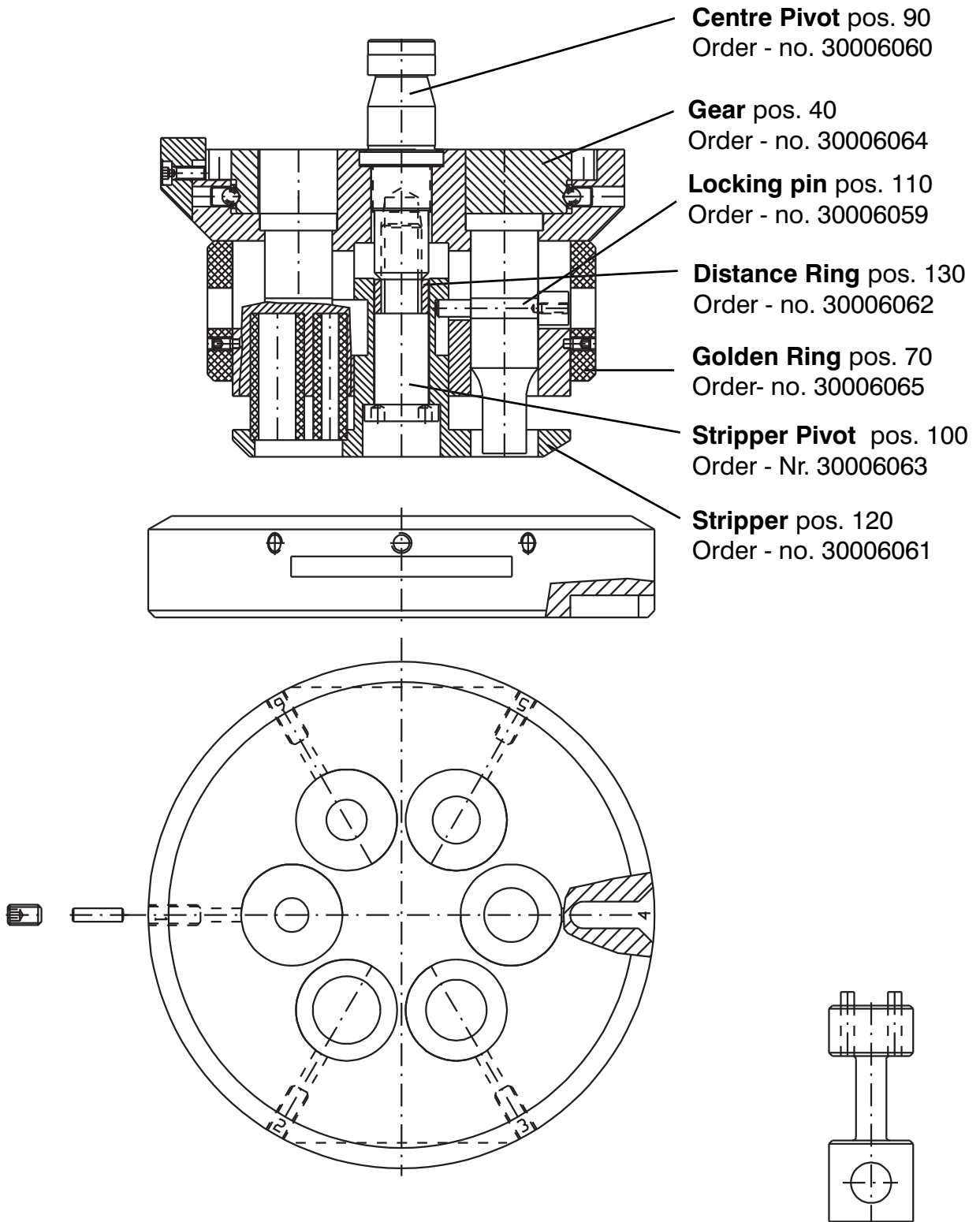

## 15.3 Spare part Revotool 7- way / 6 mm Index Rotation

31203023a

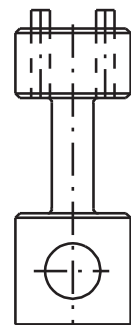
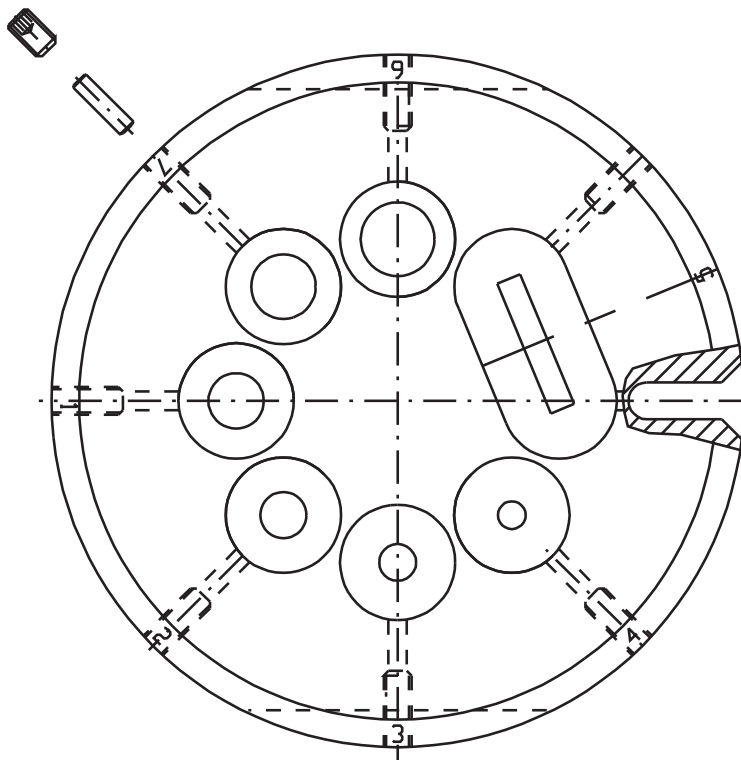
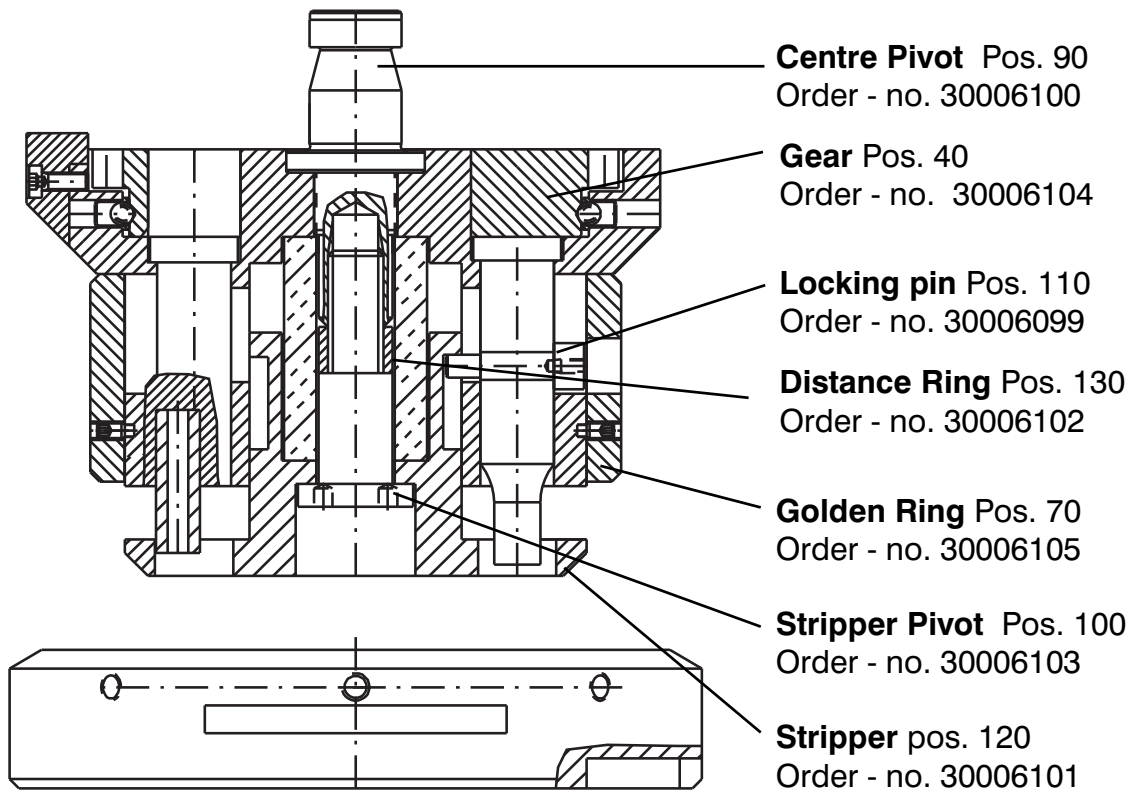



## 15.4 Spare part Revotool 7- way / 6 mm Index Rotation

### Slitting punch

5 x 30 mm

Order - no. 30006082

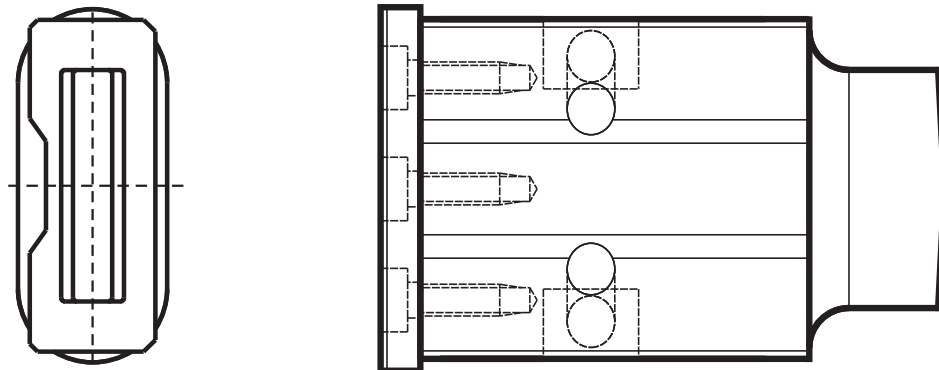

## 15.5 Spare part Revotool 8- way / 6 mm

31203007a

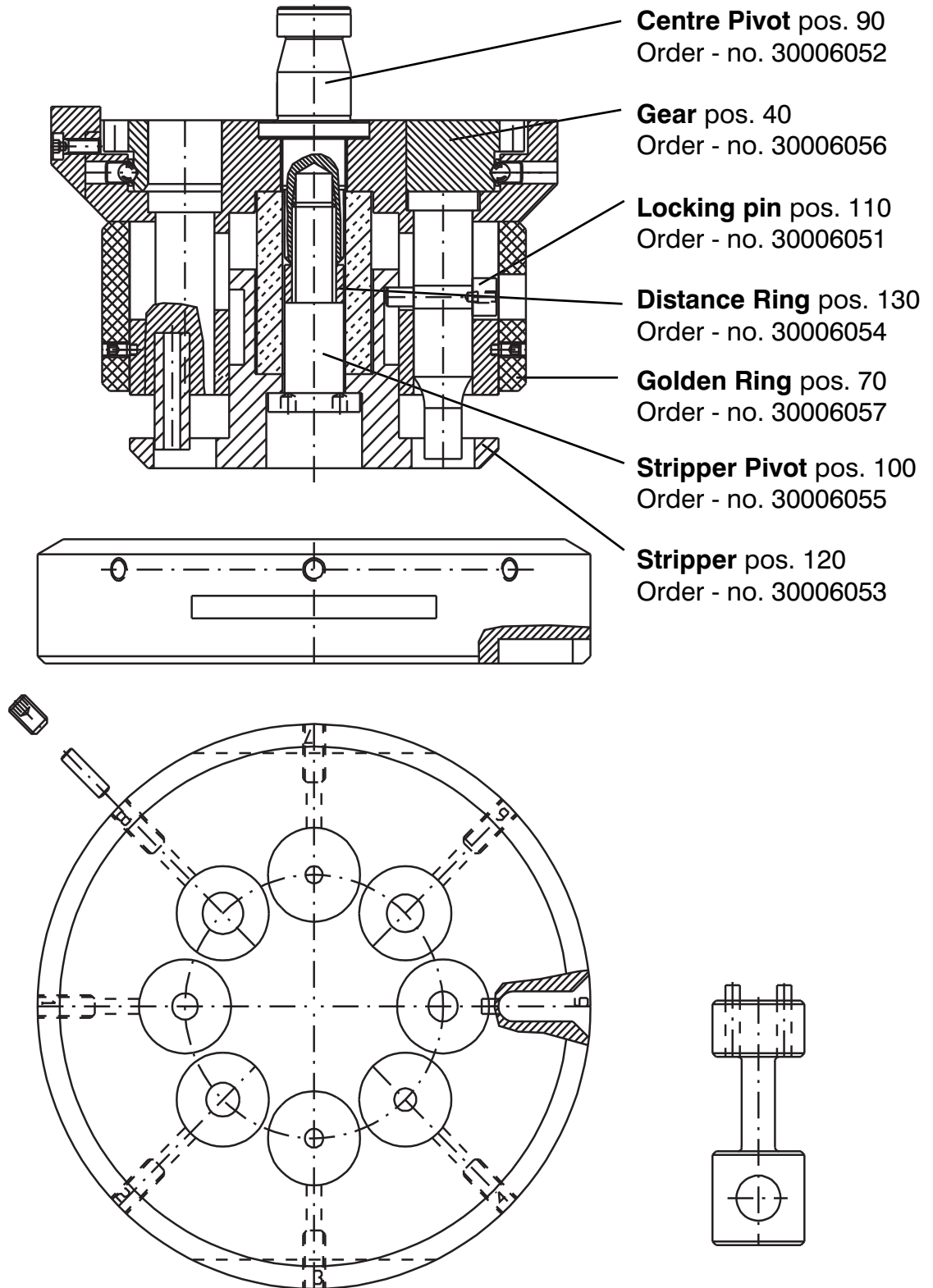

## 16 Special tools

### 16.1 Special form

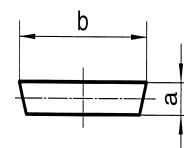
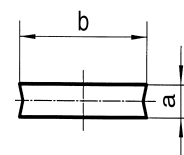
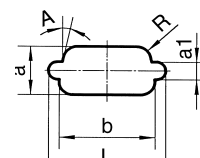
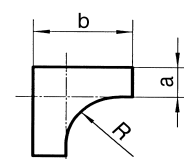
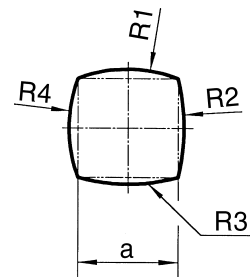
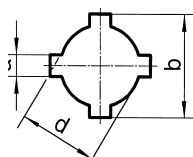
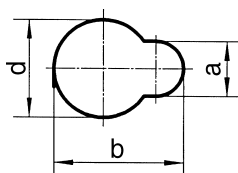
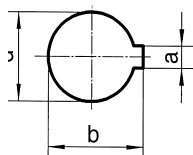
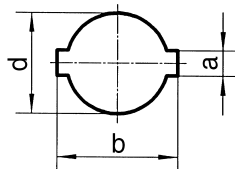
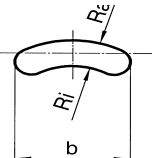
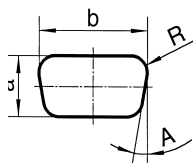
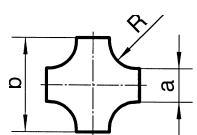
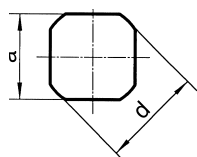
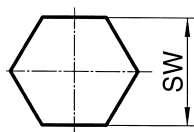
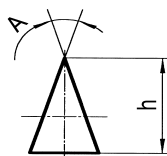
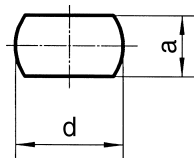
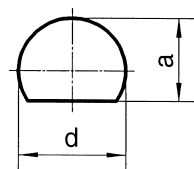

## 16.2 Forming tool

**Louvring tool**

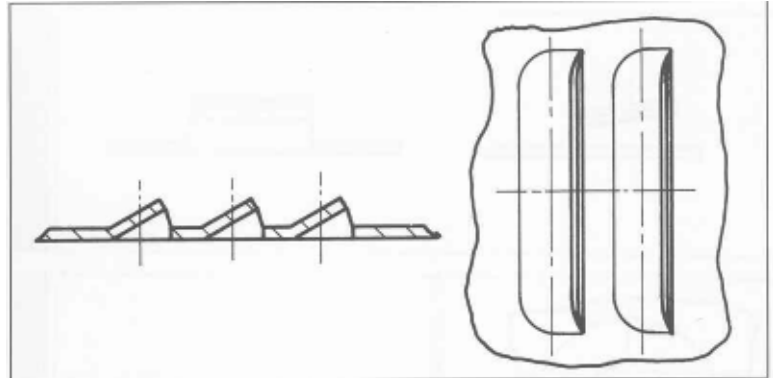

**Knockout tooling /singles**

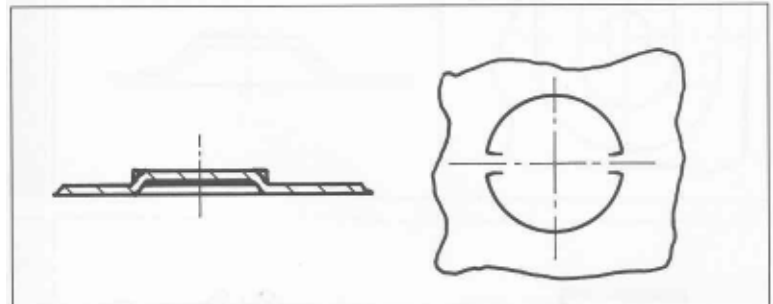

**Embossing / punch tool**



**Countersink tooling**

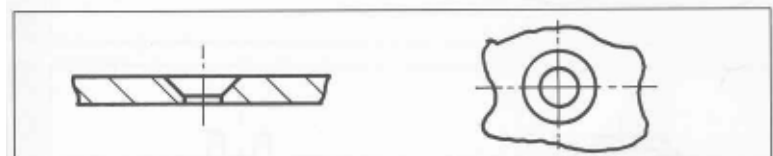

**Extrusion tooling**

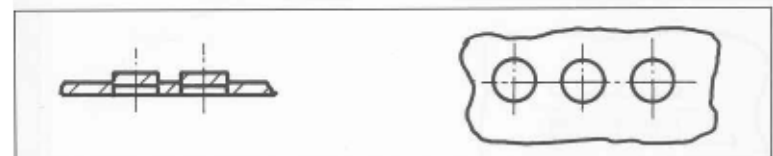

**Card guide tooling**

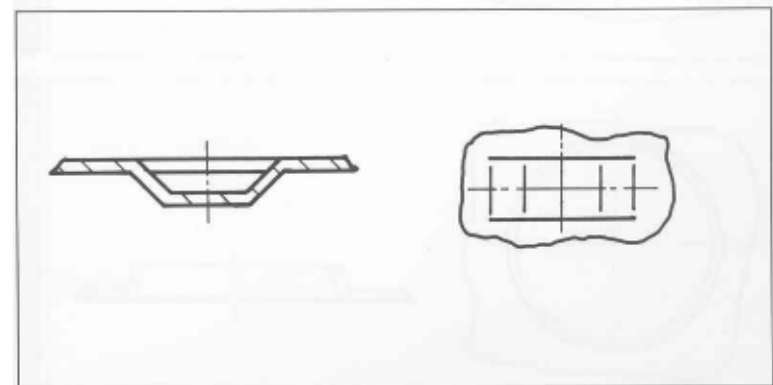

**Spring clip tooling**

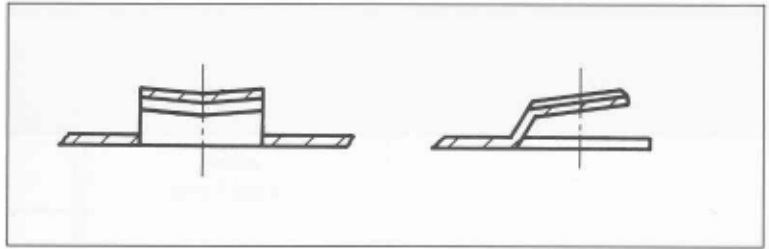

**Punch / embossing tooling**

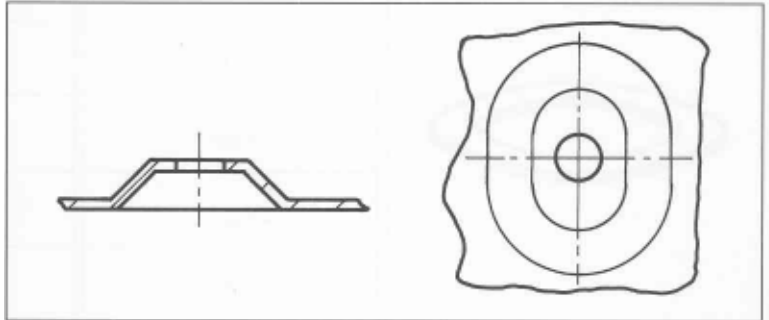

**Card guide tooling**

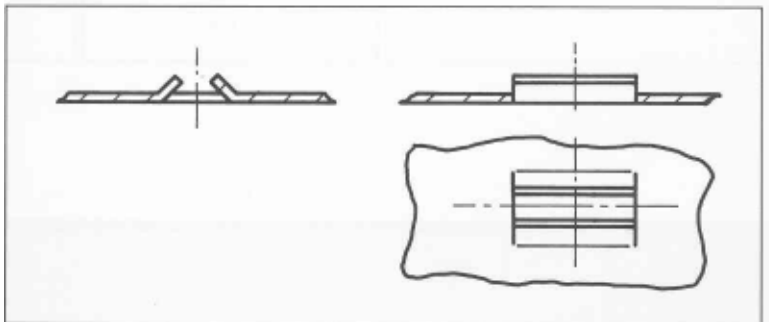

**Card guide tooling**

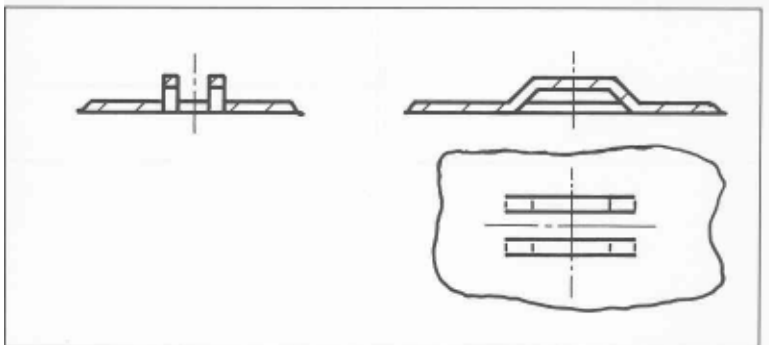

**Extrusion tooling**

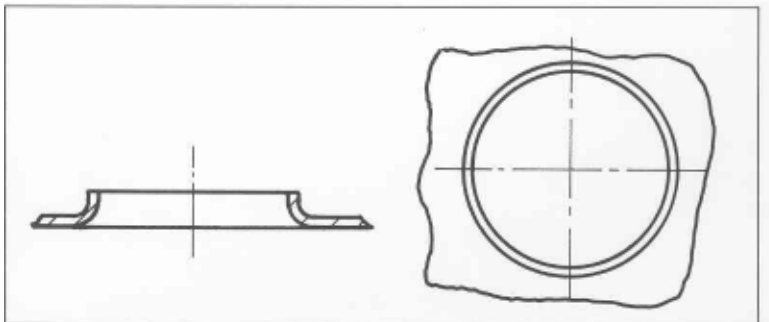

## 17 Service and Order



- Delivery ex Work - unpacked
- All toolings for all machine available

### **Spare parts delivered by us:**

- will maintain the quality and reliability of your machine
- will not adversely effect the function and safety of the machine
- are state- of- the- art and comply with EU regulations
- are covered by our guarantee

### **When ordering parts, please indicate the following data:**

- Machine model and serial number
- Name of spare part
- Article no. (if available)
- Dimensions
- Number of pieces

### **If there are any questions please do not hesitate to contact us:**

Boschert GmbH + Co. KG

Lidia Zürner

Telefon: +49 (0) 7621 - 9593 - 14

Email: l.zuerner@boschert.de

## 18 Trouble shouting

Problem	Causale	Solution
<b>Rapid Tooling wear</b>	<ul style="list-style-type: none"> <li>- bad grinded tooling</li> <li>- die clearence is too small</li> <li>- tooling is bad adjusted</li> <li>- overheating of the puch</li> </ul>	<ul style="list-style-type: none"> <li>- take enough coolant</li> <li>- adjust the grinding wheel more times</li> <li>- use a more thread one more line grinding wheel</li> <li>- make the clearence bigger</li> <li>- adjust the tooling</li> <li>- use lubricant</li> <li>- use covered punches</li> <li>- take more punches with the same sizes</li> </ul>
<b>noise/pollution because of entrained material</b>	<ul style="list-style-type: none"> <li>- to much distance to the steel stripper</li> <li>- defect PU - stripper</li> </ul>	<ul style="list-style-type: none"> <li>- reduce the distance from the steel stripper</li> <li>- use a new PU - stripper</li> </ul>
<b>Punch crash</b>	<ul style="list-style-type: none"> <li>- tooling fitting over cross</li> <li>- die clearence is too small</li> <li>- punching force is too small</li> <li>- tooling diameter is smaller than the thickness of material</li> </ul>	<ul style="list-style-type: none"> <li>- fitting position from punch and die must be agreed</li> <li>- make the clearence bigger</li> <li>- new calculation of the punching force use punches with rooftop or whisper shear</li> <li>- tooling diameter should be bigger than the thickness of material</li> </ul>
<b>Bad quality of the punched hole</b>  <b>Built- up edge at the puch</b>	<ul style="list-style-type: none"> <li>- wrong die clearence</li> <li>- blunt punch and die</li> <li>- insufficient lubricant</li> <li>- blunt tooling</li> </ul>	<ul style="list-style-type: none"> <li>- calculate the right die clearence with the help of stengthness and thickness of material</li> <li>- grind the tooling</li> <li>- lubricate the sheet regular</li> <li>- grind the tooling</li> <li>- grind a relief winkle at the punch</li> <li>- take coated punches</li> </ul>
<b>Unilateral wear at punches and dies</b>	<ul style="list-style-type: none"> <li>- punch holder is not in the centre to the die holder</li> </ul>	<ul style="list-style-type: none"> <li>- new adjustment and if necessary please contact the service of company L. Boschert</li> </ul>
<b>Break of punch chuck</b>	<ul style="list-style-type: none"> <li>- material is too thick, max. 2 mm VA, respectively 5 tons punching power</li> </ul>	<ul style="list-style-type: none"> <li>- change the tooling to size I</li> </ul>
<b>Locking piston breaks at the back</b>	<ul style="list-style-type: none"> <li>- open set collar</li> </ul>	<ul style="list-style-type: none"> <li>- close the set collar</li> </ul>
<b>Locking piston breaks at the front</b>	<ul style="list-style-type: none"> <li>- the stripper peg is loose</li> </ul>	<ul style="list-style-type: none"> <li>- stick in the stripper peg</li> </ul>

# Trouble shouting



Problem	Causale	Solution
Sheet get caught	- not enough power of the stripper - sheet thickness 2,5 - 6,0 mm	- use an additional steel stripper
Result of the punching at the sheet is very bad, sheet get caught.	- sheet will be taken upwards with the punch	- use a special thin sheet stripper

**Distributeur:**  
**S.C. SM TECH S.R.L.**  
**www.sm-tech.ro**  
**office @ sm-tech.ro**  
**Tel : 0745-528494**  
**Tel/Fax: 0231-515702**



Empty rounded rectangular box at the top left of the page.



Personal Notes

A large grid area for taking notes, consisting of many small squares.