

GIRRI

130

- SLIDING GATE OPERATOR
- ELECTRO-MECHANICAL
- SELF-BRAKING OPERATOR FITTED WITH CUT OFF LIMIT SWITCH



INSTALLATION MANUAL

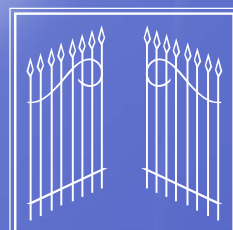

FADINI[®]
the gate opener

ELECTRO-MECHANICAL SLIDING GATE OPERATOR **GIRRI 130**

CUT AWAY SIDE VIEW OF THE ELECTRO-MECHANICAL OPERATOR GIRRI 130 FOR SLIDING GATES

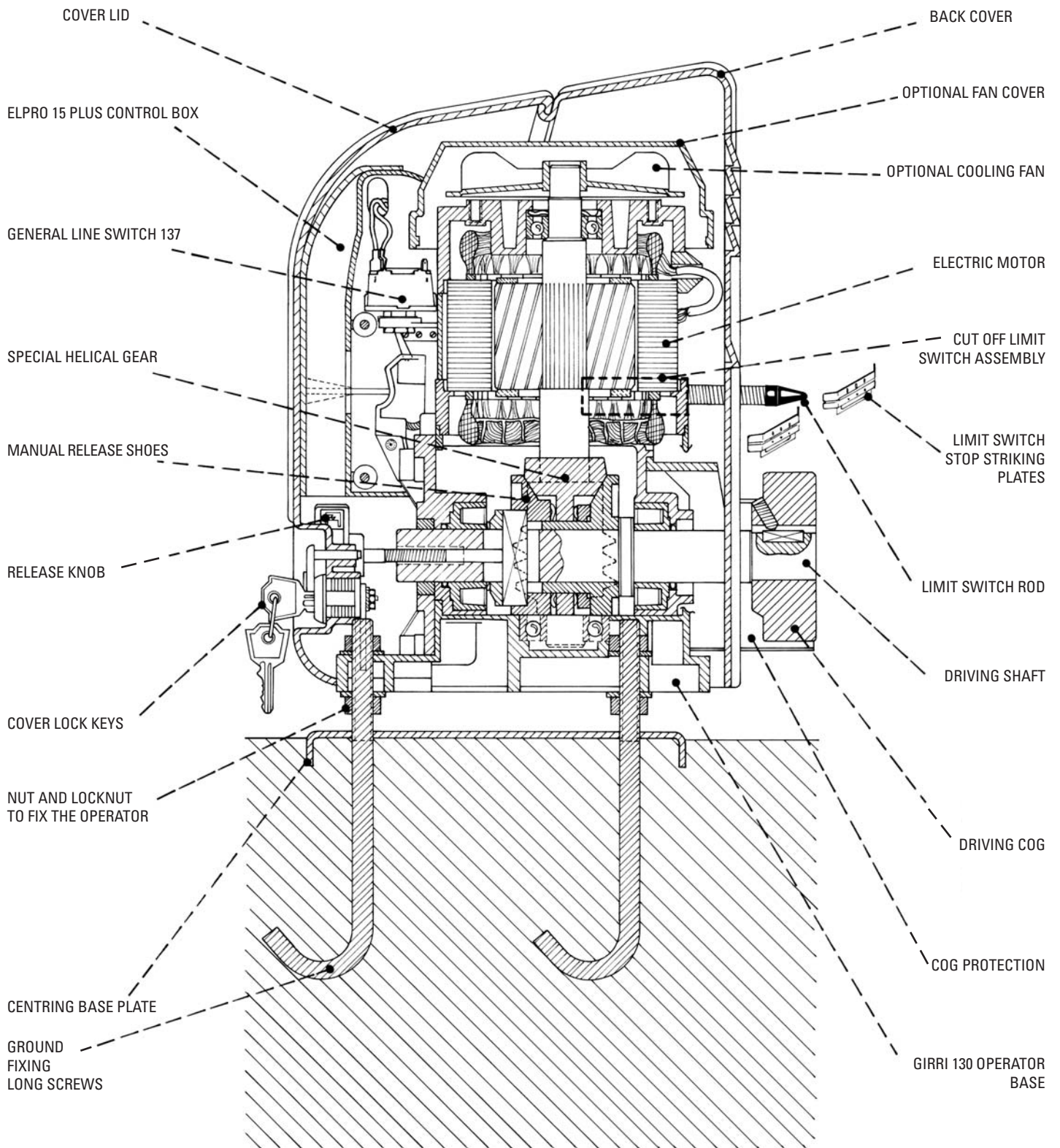

FIXING DETAIL WITH PARTS LAYOUT OF THE ELECTRO-MECHANICAL GATE OPERATOR GIRRI 130

INSTRUCTIONS FOR THE INSTALLATION OF GIRRI 130 ON TO SLIDING GATES

To achieve a perfect application and performance of GIRRI 130, you must follow the steps and the drawings here below:

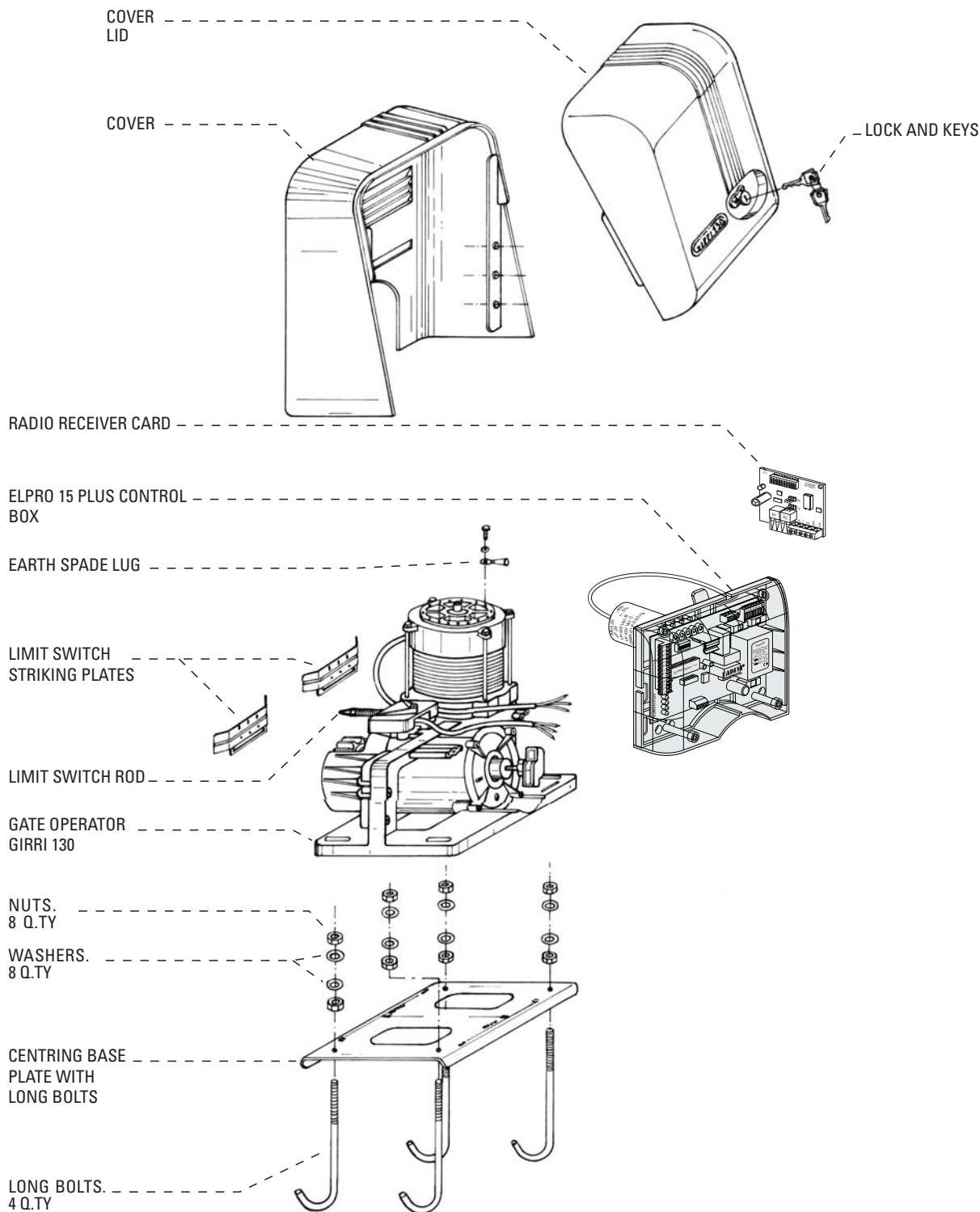

PIC. 1 ◀

First remove the lid by means of the supplied keys; this will reveal the electronic control box with its transparent plastic cover, the operator base plate, the knob to release the cog for hand operation of the gate. You will be also able to see the motor top fitted with a spade lug for the proper earthing of the equipment. All the electrical components inside the gear box are pre-wired and pre-terminated in the electronic control box. The wires from the outside safety and command devices are led into the box through the hole on the left-hand side of the motor base plate and centring fixing plate. See picture 1 showing the various components.

1st OPERATION

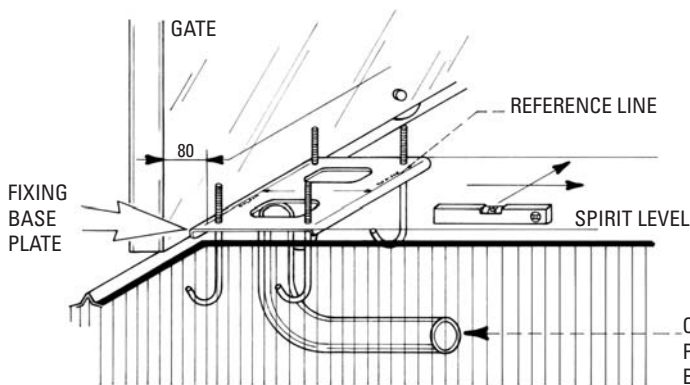

Before setting the fixing base plate with concrete fully screw up the 4 long bolts so that the threads are all out. Set the plate horizontally levelled as shown in the illustration at 80 mm from the gate. Corner "A" of GIRRI 130 base plate is to coincide with the reference line drawn on the fixing base plate.

➤ **PIC. 2**

2nd OPERATION

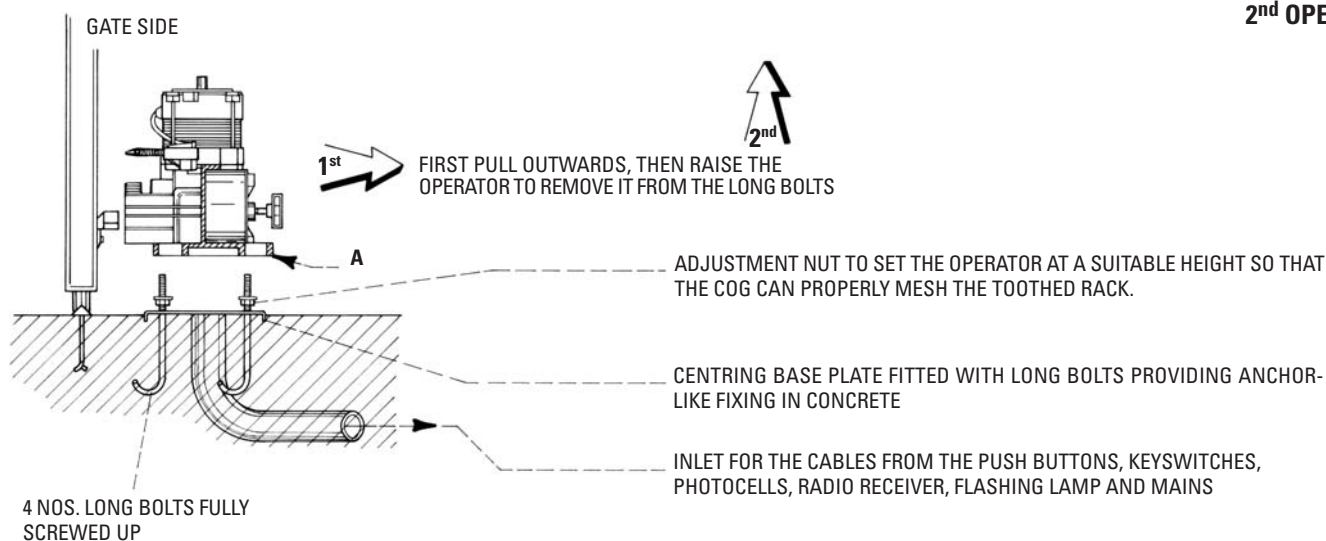

PIC. 3 ◀

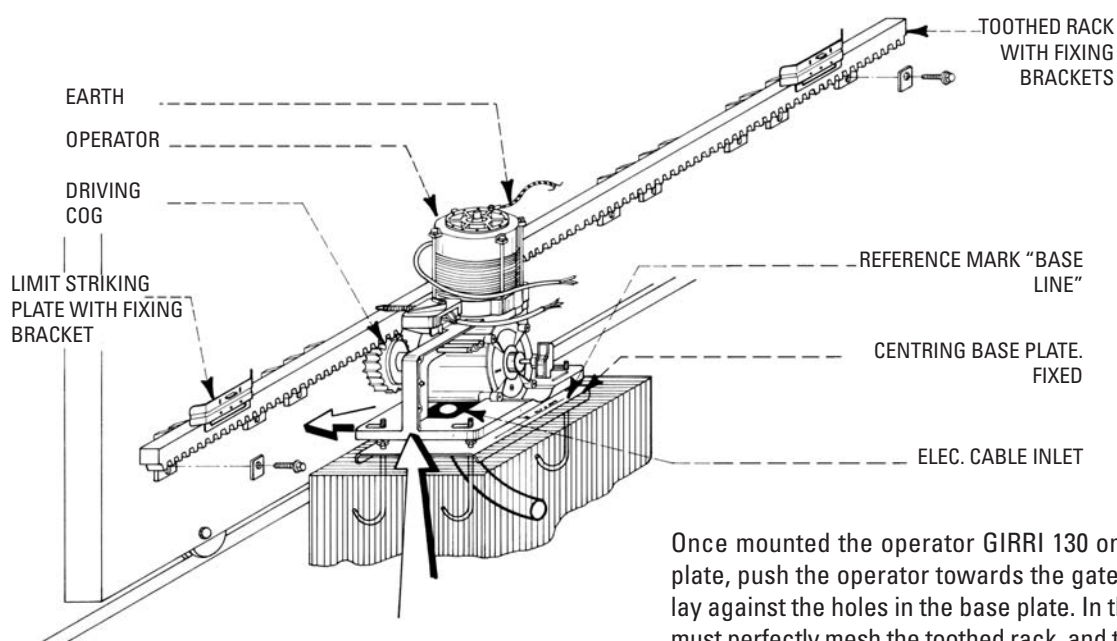

Once mounted the operator GIRRI 130 on to the fixing base plate, push the operator towards the gate until the four bolts lay against the holes in the base plate. In this position the cog must perfectly mesh the toothed rack, and the "base reference line" is fully visible. To remove the operator, first unscrew the 4 nuts, pull the operator towards the outside so to free the cog from the toothed rack.

➤ **PIC. 4**

IT IS IMPORTANT THAT ALL THE ELECTRIC CABLES ARE DISCONNECTED

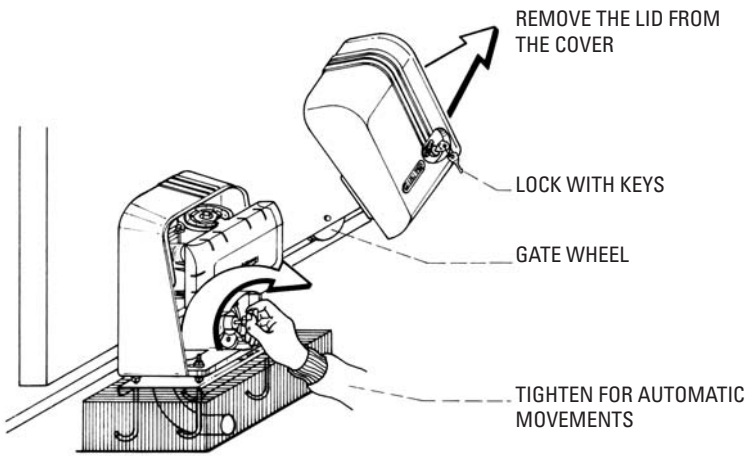

PIC. 5

Remove the cover to lock or release the operator (Pic. 5-6).

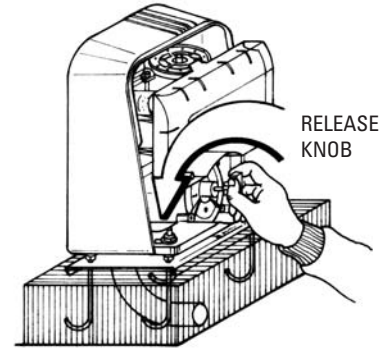

PIC. 6

To release for manual operations 3 turns anti-clockwise.

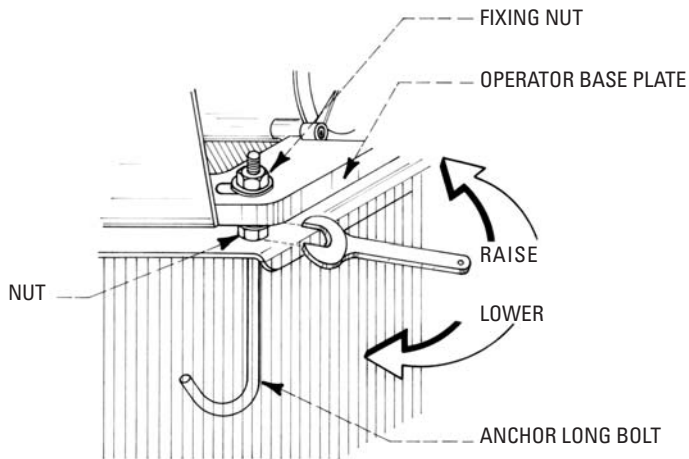

PIC. 7

Once fixed the operator on its concrete mounting you can carry on fixing the toothed rack by means of the supplied brackets and screws. The position of the toothed rack must be as close as possible to the cog to achieve a correct meshing, after having released the operator to the idle position as shown in picture 6. Eventually, once fixed the toothed rack, adjust the position of the operator up to the correct level so that the cog and the toothed rack mesh each other with sufficient clearance. For this operation use the 4 nuts as shown in picture 7.

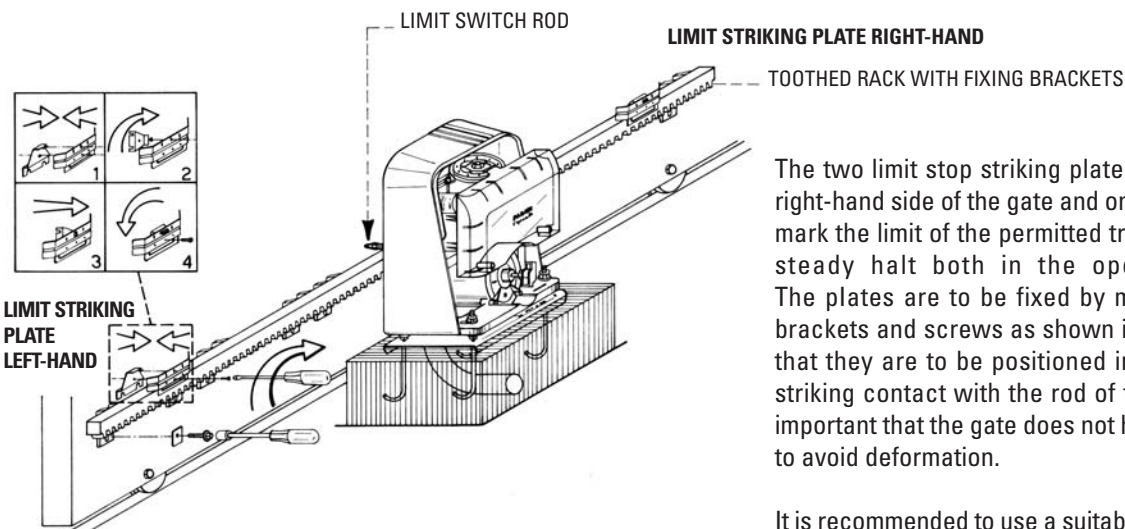

PIC. 8

The two limit stop striking plates are to be fixed one to the right-hand side of the gate and one to the left-hand side. They mark the limit of the permitted travel and bring the gate to a steady halt both in the open and close positions. The plates are to be fixed by means of suitably designed brackets and screws as shown in picture 8; it is understood that they are to be positioned in a way to allow a suitable striking contact with the rod of the cut off limit switch. It is important that the gate does not hit the gate post or gate stop to avoid deformation.

It is recommended to use a suitable support under the junction points of the rack lengths for a more precise welding operation.

IMPORTANT: it is recommended to fit gate stops at the limit open and closed gate positions (Pic.9).

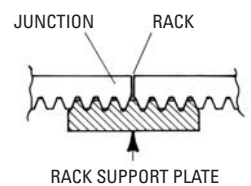

FIT THE MOVING GATE WITH A METALLIC NET SHOULD THE PATTERN HAVE GAPS WIDER THAN 8mm

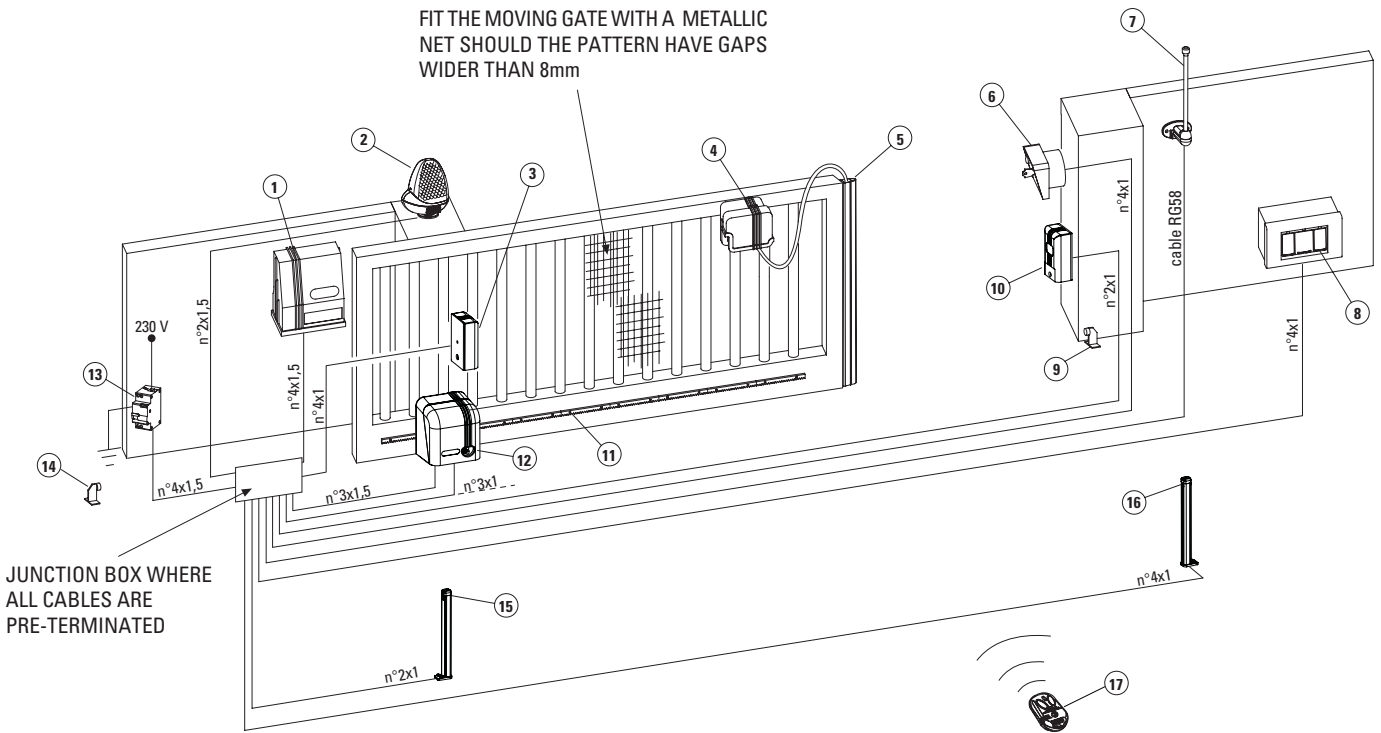

IMPORTANT: All the electrical equipment to be properly earthed.

- | | |
|---|---|
| 1 - Remote-controlled switch receiver CRUASTRO | 11 - Rack |
| 2 - Flashing lamp MIRI 4 | 12 - Geared motor GIRRI 130 c/w Elpro 15 Plus control board and plug-in radio receiver PCB Astro 43/2 R |
| 3 - Photocell receiver TRIFO 11 | 13 - Magnetic thermal Differential 230V 50Hz circuit breaker 0.03A (beyond 100m use Ø2.5mm cables) |
| 4 - Remote-controlled switch transmitter CRUASTRO | 14 - Open gate stop |
| 5 - Pneumatic safety edge or sensitive barrier | 15 - Post with photocell Transmitter TRIFO 11 |
| 6 - Keyswitch PRIT 19 | 16 - Post with photocell Receiver TRIFO 11 |
| 7 - Aerial BIRIO A8 | 17 - Transmitter ASTRO 43/2 TR Small |
| 8 - Push button switch PULIN 3 | |
| 9 - Close gate stop | |
| 10 - Photocell transmitter TRIFO 11 | |

PIC. 9

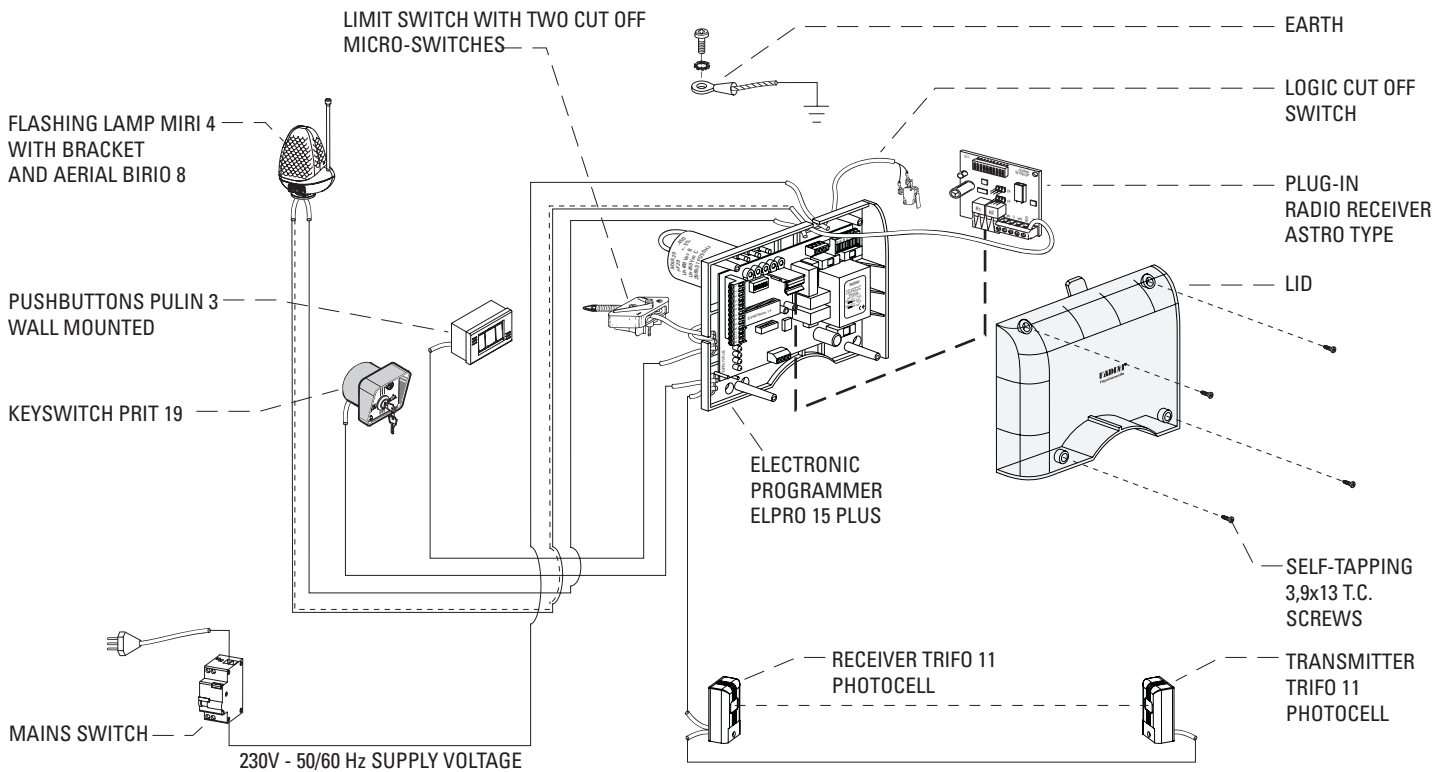

PIC. 10

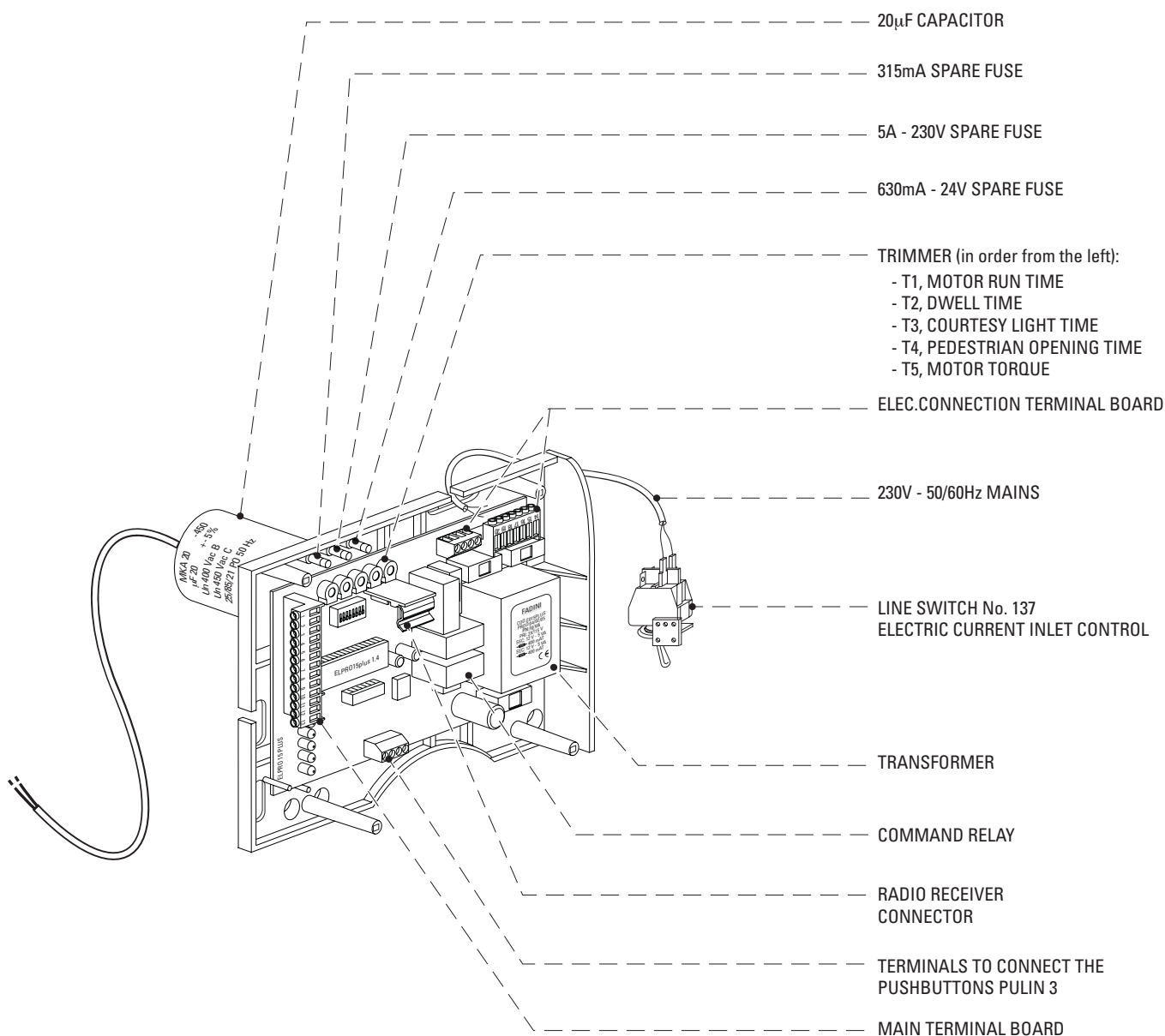

PIC. 11 ◀

CE EUROPEAN MARK CERTIFYING CONFORMITY TO THE ESSENTIAL REQUIREMENTS OF THE STANDARDS 98/37/EC

The "CE" mark certifies that the operator conforms to the essential requirements of the European Directive art. 10 EEC 73/23, in relation to the manufacturer's declaration for the supplied items, in compliance with the body of the regulations ISO 9000= UNI EN 29000. AUTOMATION IN CONFORMITY TO EN 12453, EN 12445 SAFETY STANDARD.

For the application of the "CE" mark it is recommended to have the operator fitted with item No. 137 the line switch.
- This switch is fitted on the customer's request if an order for GIRRI 130 with CE sticker on it is received.

The wires from the electronic programmer to the electric motor have a 1.5 mm square section. For the limit switches, the photocells, the keyswitch/push buttons and other accessories 1.0 mm square section wires can be used; but for the mains and the flashing lamp the recommended section is 1.5 mm, as shown in picture 9. Elpro 15 Plus is designed to operate in automatic or semiautomatic modes through the accessories as shown in diagram No. 10. The electric motor, limit switches and safety micro-switch are pre-connected.



IDENTIFICATION PLATE

Elpro 15 PLUS

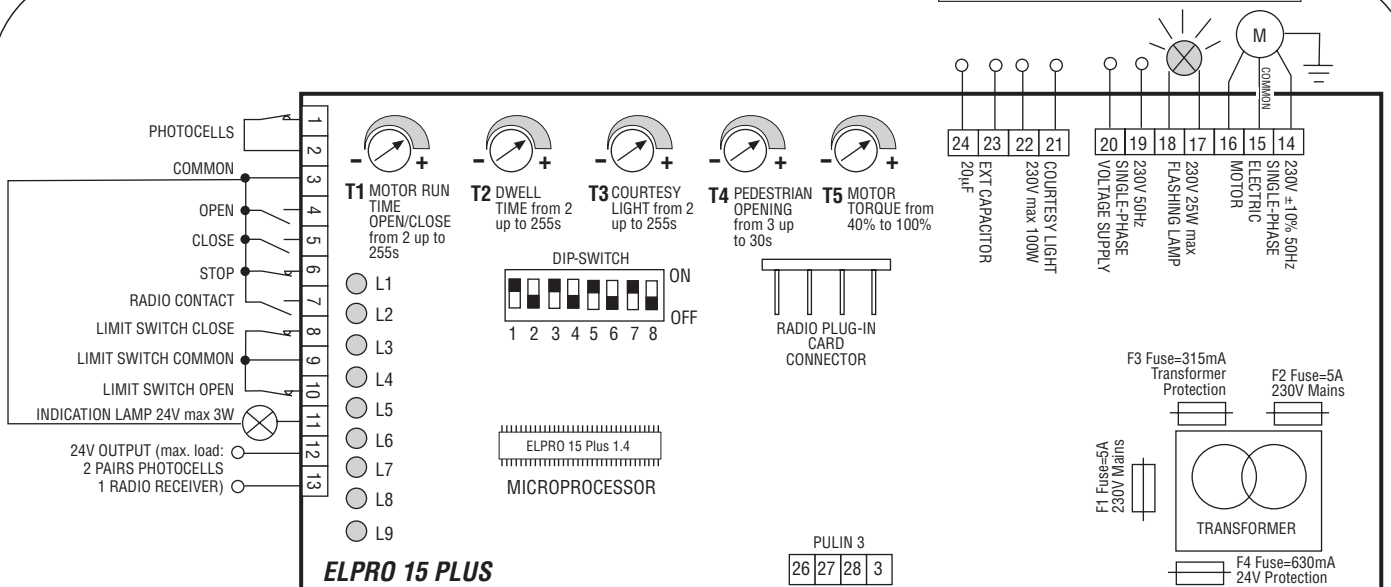

The electronic control panel Elpro 15 Plus, new generation, is designed to operate the sliding gate operator Girri 130. Power supply is 230V 50Hz single-phase. Built in full compliance with BT 93/68/CE Low Voltage and EMC 93/68/CE Electro-Magnetic Compatibility Regulations. Fitting operations are recommended by a qualified technician in conformity to the existing safety standards. The manufacturing company declines any responsibility for incorrect handling and application; also, it reserves the right to change or update the control panel any time.

PLEASE NOTE:

- The control panel is fitted inside Girri 130.
 - Make sure that the power supply to the electronic programmer is 230V ±10%
 - Make sure that the power supply to the Electric Motor is 230V ±10%
 - Fit the mains to the control panel with a 0.03A high performance circuit breaker.
 - Use 1.5mm² section wires for voltage supply, electric motor and flashing lamp. Maximum recommended distance 50m.
 - Use 1mm² section wires for limit switches, photocells, push-buttons/key-switch and accessories.
 - Bridge terminals 1 and 2 if no photocells are required.
 - Bridge terminals 3 and 6 if no key- or push-button switches are required.
- N.W: To fit extra accessories such as lights, CCTV etc. use only solid state relays to prevent damages to the microprocessor.

Dip-Switch:

- 1= ON. Photocells. Stop while opening
- 2= ON. Radio. No reversing while opening
- 3= ON. Automatic closing
- 4= ON. Preflashing activated
- 5= ON. Radio. Step by step. Stop in between
- 6= ON. Dead Man Control (Dip 4=OFF and Dip 3=OFF)
- 7= ON. No lamp on during dwell time
- 8= OFF. No function

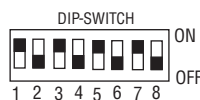

Led Status Indication:

- L1= 230V 50Hz power supply. Alight
- L2= Photocells, if obstructed light goes off
- L3= Open. Alight whenever an Open pulse is given
- L4= Close. Alight whenever a Close pulse is given
- L5= Stop. It goes off on pulsing Stop
- L6= Radio. It goes on by pressing a transmitter button
- L7= Gate Status; it flashes on gate moving
- L8= Limit switch Close; off when gate is closed
- L9= Limit switch Open; off when gate is open

In case of failure of the panel:

- Make sure that the power supply to the electronic programmer is 230V ±10%
- Make sure that the power supply to the Electric Motor is 230V ±10%
- Check fuses
- Check photocells if contacts are normally closed
- Check that no voltage drop has occurred from the control panel to the electric motor

LOW VOLTAGE ELECTRICAL CONNECTIONS

Photocells and Safety Edge:

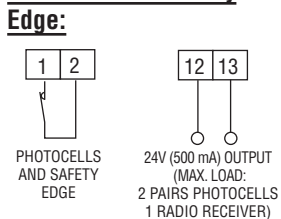

DIP-SWITCH 1:

- ON: Photocells stop gate while opening, reverse it on closing once obstacle is removed
- OFF: Photocells do not stop gate while opening, reverse it in case of an obstacle on closing

Button switch:

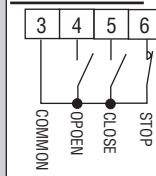

Radio Contact:

- Open/Close (Standard)
- Travel reversing on pulsing
- Step by step

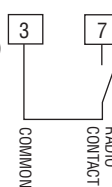

DIP-SWITCH 2 and 5 (NEVER set BOTH of them ON at the same time):

- ON: Gate is not reversed while opening
- OFF: Any pulse reverses the gate

- ON: Step by step. Stop in between
- OFF: Standard operating mode

Limit switch:

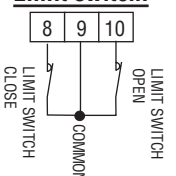

24V 3W Indication Light:

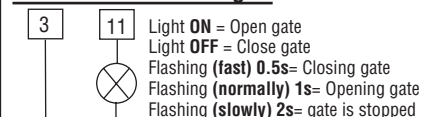

Push Button Switch Pulin 3:

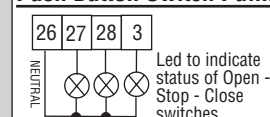

Drwg. No. 4136

ELECTRICAL POWER CONNECTIONS

Capacitor and Single-phase Motor:

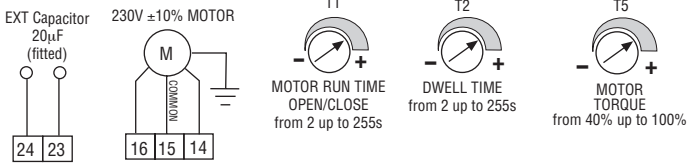

Flashing lamp:

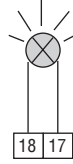

DIP-SWITCH 4 and 7:

- 4**
- ON: Pre-flashing
 - OFF: No pre-flashing
- 7**
- ON: Lamp is not operating during Dwell time. Automatic mode.
 - OFF: It flashes during Dwell Time. Automatic Mode.

Power supply:

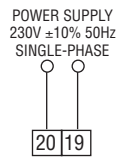

Courtesy Light 230V max 100W:

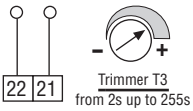

OPERATING MODES

Automatic / Semiautomatic:

Automatic Operation: any pulse opens the gate, the gate stays open as long as the Dwell time expires as set by T2 trimmer, then it closes automatically, no pulsing is required.

Semi-automatic Operation: any pulse opens the gate that stays open. A second pulse to Close is required for the gate to close.

DIP-SWITCH N°3

- ON= Automatic Closing
- OFF= No Automatic. Semi-automatic closing by pulse

Hold on switched (Deadman) control:

Open and Close operations are achieved "by holding a switch on" (no relay self-holding is involved) therefore a physical attendance is required to keep the gate opening or closing until either the button or key is released.

DIP-SWITCH N°6=ON

- ON= Deadman Control. Dip-switch 4=OFF and Dip-switch 3=OFF
- OFF= Standard Operations

Pedestrian Opening:

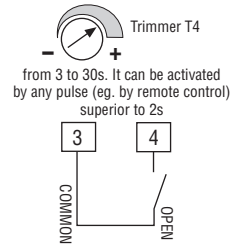

Time clock installation:

How it works: Set the clock to the required times. On the pre-set time the gate is automatically opened and held open. Any further pulsing (even by remote control) is not accepted by the system until the time pre-set by the clock has expired. On expiring and after the pre-set dwell time the gate is closed automatically. T4 trimmer on to zero, Dip-Switch 3=ON.



DIP-SWITCH No.3=ON Automatic Closing

- ON= Automatic Closing
- OFF= No Automatic. Semi-automatic closing by pulse

External Time Clock

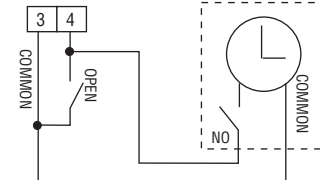

Drwg. No. 4136

PIC. 12

- Please note that a **low voltage** cut off switch is fitted to the right side of the control box. The contacts are closed when the operator lid is put back (Pic. 13).

- Instead of the low voltage cut off microswitch (ie. LOGIC switch) see Pic. 13, you can request and have a line switch fitted to interrupt the mains. Like the other one, it is also controlled by the operator lid when you remove it or put it back to the original correct position by means of the specially toothed key. Once the lid is locked back, you have the certainty of the made contact.

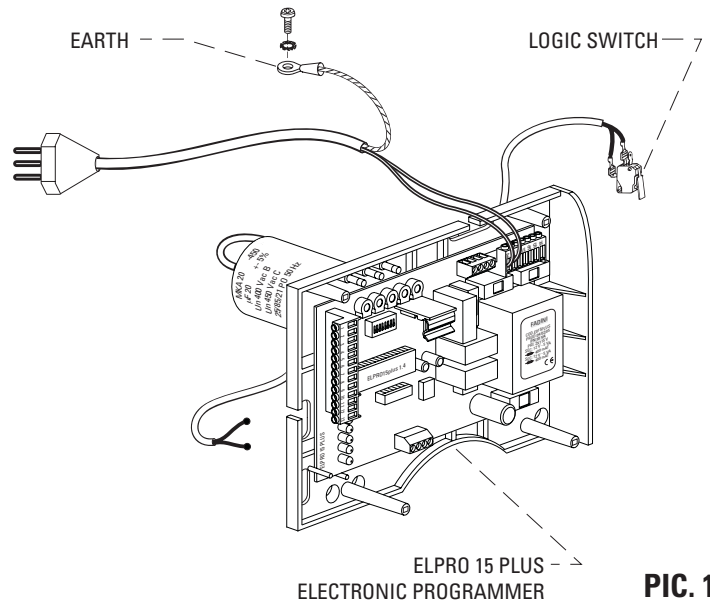

PIC. 13

“General Line Switch” electric current inlet (Pic. 14).

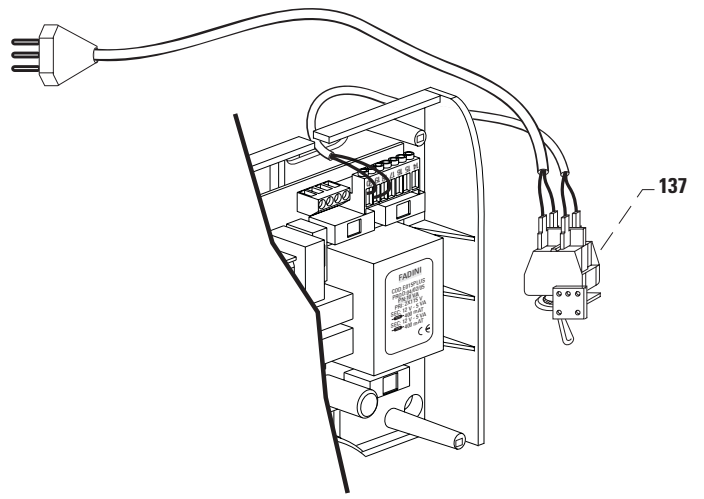

PIC. 14 ◀

- It is recommended to make all the connections as described in the diagram No. 4136 which is included inside the control box; the diagram describes the features of the control panel and how to plug in the radio receiver for the automatic operation by transmitter (Pic. 12).

- Also, should the motor fails when pulsed to start because of shortage of electric power, parallel connect a 12.5 μ F capacitor in addition to the existing one (Pic. 15).

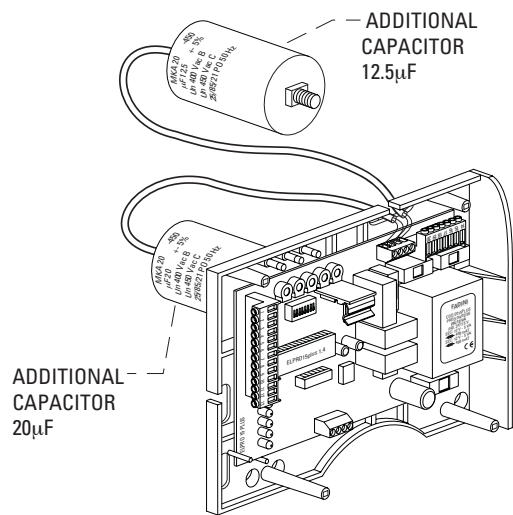

PIC. 15 ◀

To increase the torque of the electric motor, adjust the Motor Torque Trimmer **T5**. Pic. 16.

Turn the trimmer to the right to increase the torque or the other way to the left to decrease it. Pic. 17.

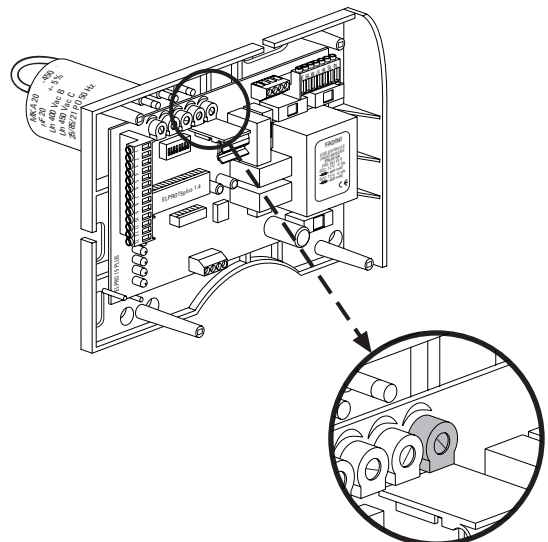

PIC. 16 ◀

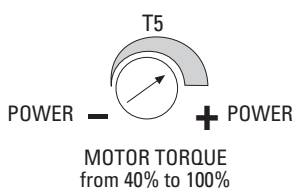

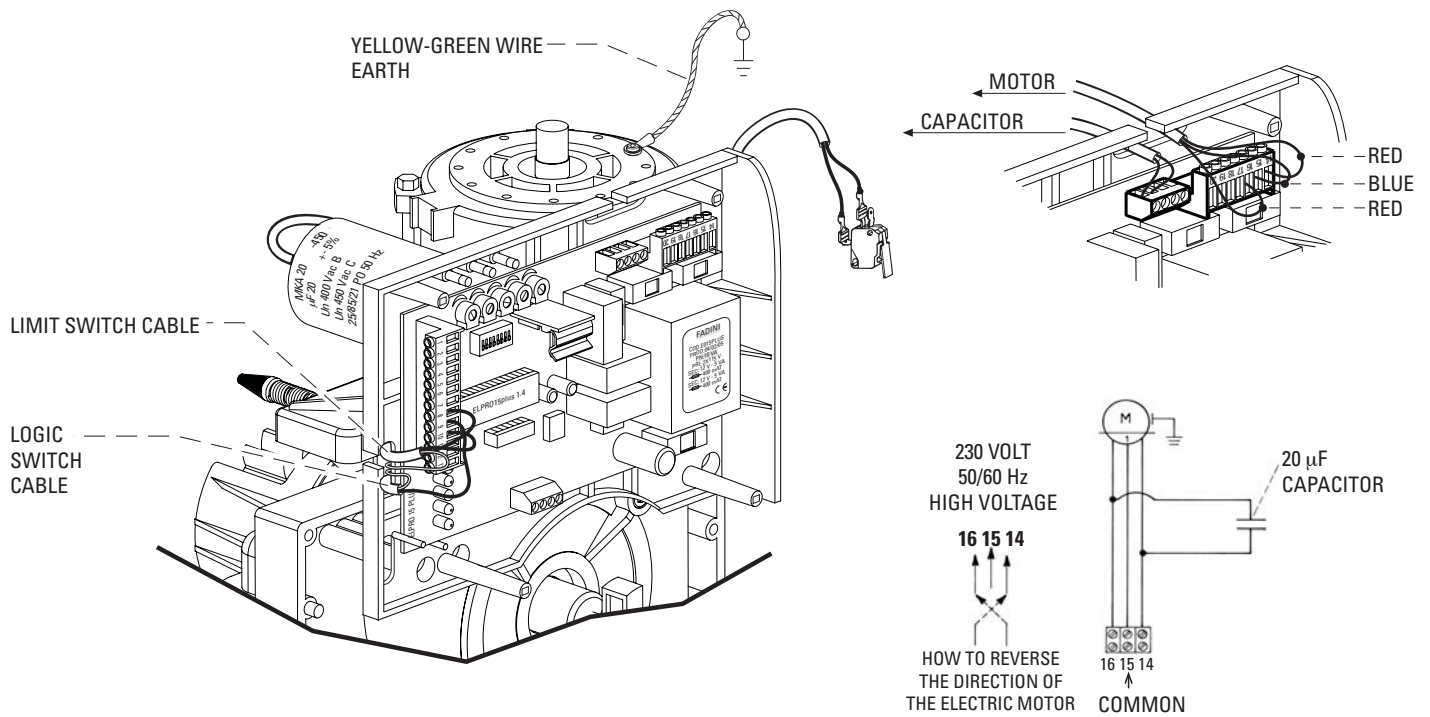

PIC. 18 ◀

If, during the first run test, you realize that the electric motor turns in the wrong direction and the limit switch rod is not activated (that is when the limit switch rod is pushed in the same direction of the gate, which does not stop), you must remove the cover and reverse the position of the electric motor wires 16 and 14, change over No. 16 to 14 and No. 14 to No. 16. See picture 18.

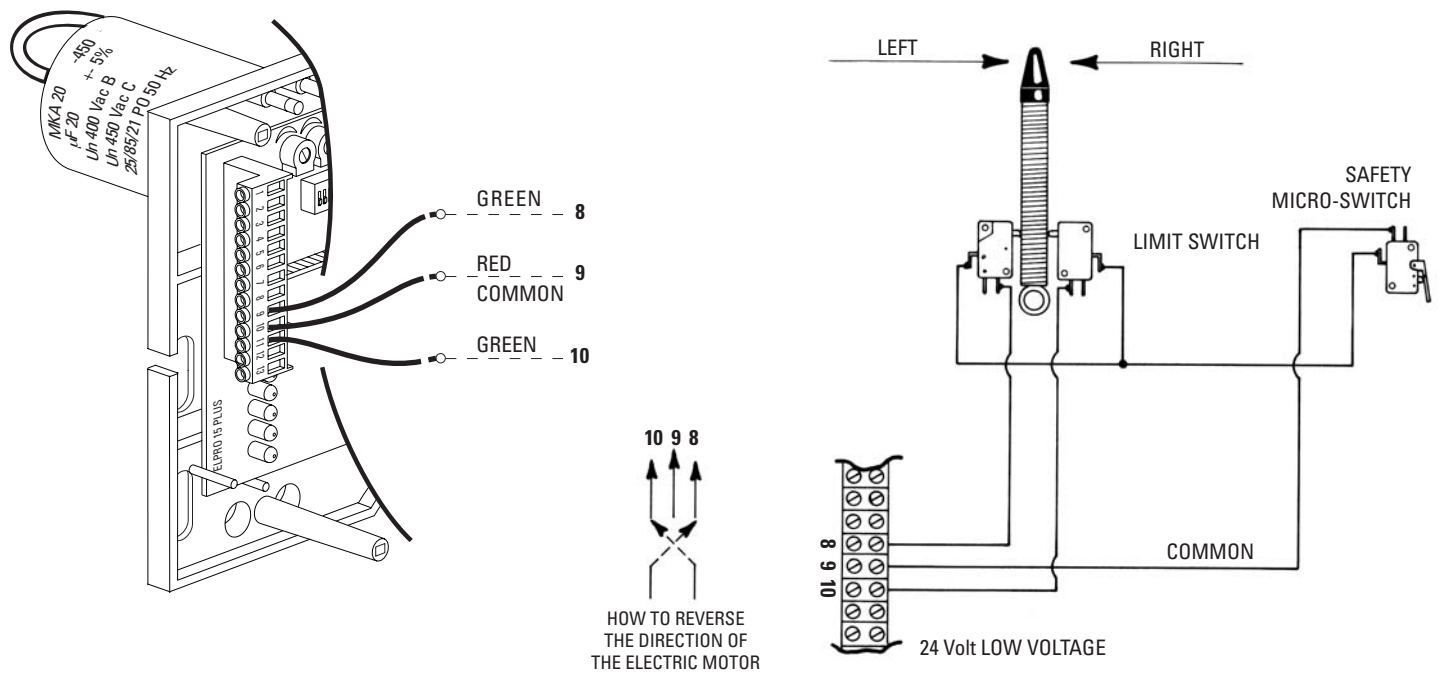

PIC. 19 ◀

Once the electric motor wires have been swapped around, you must also reverse the two limit switch wires in the terminal board. See Pic. 19. Swap No. 8 with No. 10 and No. 10 with No. 8. Once satisfied that the electrical connections are now all right, repeat the test: the motor starts, the gate moves to the right and, by pushing the limit switch rod to the right, it must stop at once; should it not, swap again the wires No. 8 and 10.

It is important that the limit switches are activated according to the rotation direction of the electric motor; in fact, during the "dwell" time, the gate fully open, automatic mode, the limit switch "open" controls the seconds the gate has to stay open before it is automatically pulsed to close after the dwell time as pre-set by trimmer T2 (Pic.12 pages 8-9).

CHECKING AND MAINTENANCE:

To achieve an optimum performance and longer life of the equipment and in observance of the safety regulations, it is recommended that inspections and proper maintenance are made by qualified technicians to the whole installation ie. both the mechanical and electronic parts, as well as wiring.

- Mechanical parts: maintenance every 6 months approx.
- Electronic apparatus and safety equipment: maintenance every month approx.

GIRRI 130 TECHNICAL SPECIFICATIONS

OVERALL DIMENSIONS

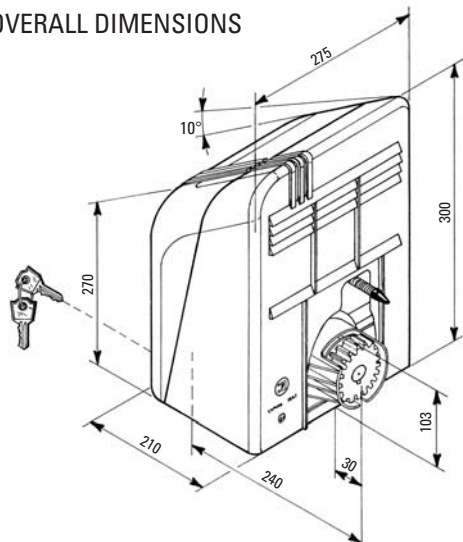

FIXING BASE PLATE

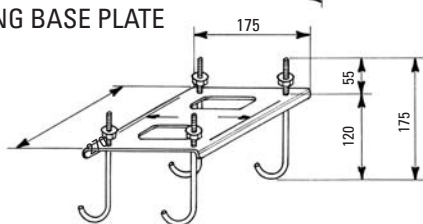

ELECTRIC MOTOR

Power output.....	0.25 KW (0.33 HP)
Supply voltage	230 V
Frequency.....	50 Hz
Absorbed power.....	530 W
Absorbed current.....	2.5 A
Insulation class.....	F
Motor rotation speed	1'320 r.p.m.
Capacitor.....	20 µF/450 V
Intermittent service	S 3

ELECTRO-MECHANICAL OPERATOR

Type of lubrication by AGIP	MU/EP1 grease
Travel speed	10 m/min.
Rated torque.....	28.0 Nm
Weight of the operator.....	14 Kg
Static weight of the gate	400 Kg
Gear rating.....	1/30
Working temperature.....	-25°C +70°C
Protection standards.....	IP 535
Duty cycles.....	30 sec. Open - 30 sec. Dwell - 30 sec. Close
Time of one complete cycle.....	90 s
Complete cycles Open-Dwell-Close.....	No 40/hour
Cycles per year, 8 hour service per day.....	No 116'000

WARNINGS

- Before installing the equipment carry out a **Risk Analysis** and fit any required device in compliance with EN 12445 and EN 12453 Safety Norms.
- It is highly recommended to keep to these instructions. Check the specifications on the motor label with the site voltage supply.
- Dispose properly of the packaging materials such as cardboard, nylon and polystyrene through specialized companies.
- Should the operator be removed for servicing or repairing, **do not cut away** the electrical wires, but properly remove the terminal boards from their seat.
- All the equipment must be duly earthed by means of the specifically provided earthing screw.
- It is also advised to carefully read the regulations, advice and suggestions in the book "Safety Norms".



FADINI
the gate opener
Made in Italy

The growth of MECCANICA FADINI has always been based on the development of guaranteed products thanks to our "TOTAL QUALITY CONTROL" system which ensures constant quality standards, updated knowledge of the European Standards and compliance with their requirements, in view of an ever increasing process of improvement.

The "CE" mark certifies that the operator conforms to the essential requirements of the European Directive art. 10 EEC 73/23, in relation to the manufacturer's declaration for the supplied items, in compliance with the body of the regulations ISO 9000= UNI EN 29000. Automation in conformity to EN 12453, EN 12445 safety standards.

CE EUROPEAN MARK CERTIFYING CONFORMITY TO THE ESSENTIAL REQUIREMENTS OF THE STANDARDS 98/37/EC

- DECLARATION OF CONFORMITY
- SAFETY NORMS
- EN 12453, EN 12445 STANDARDS
- CEI EN 60204-1 STANDARDS
- WARRANTY CERTIFICATE ON THE CUSTOMER'S REQUEST



AUTOMATIC GATE MANUFACTURERS

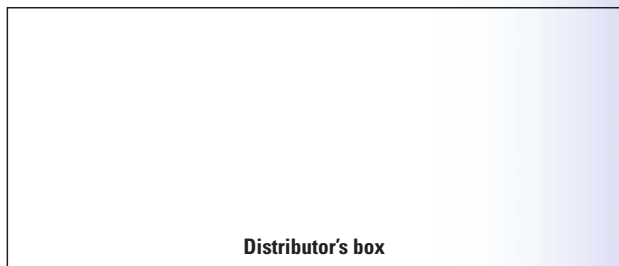

The manufacturers reserve the right to change the products without any previous notice