

Reactive Power Controller

Prophi®

Operating instructions

Brief instructions see last page

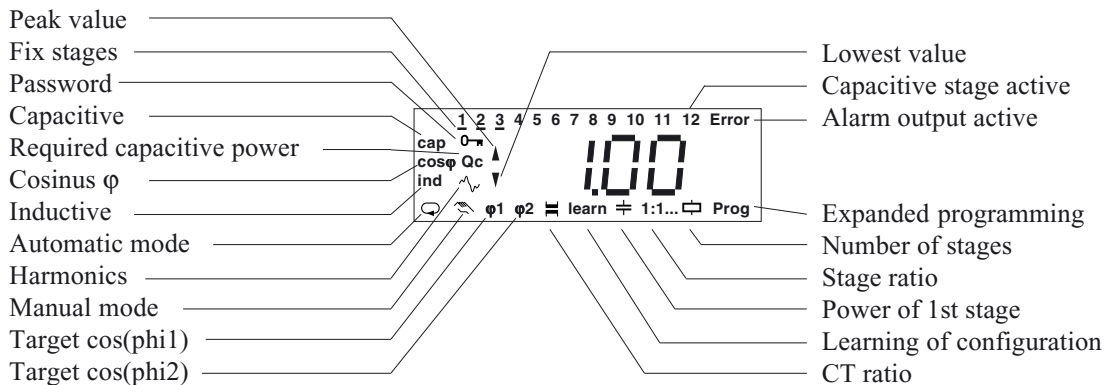
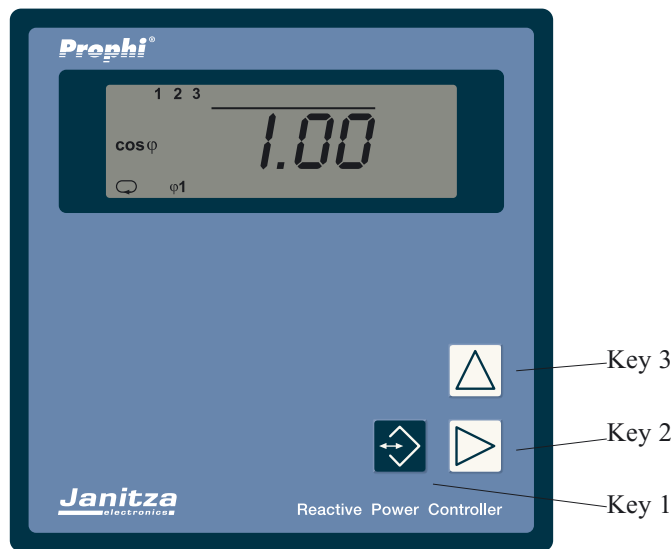

Contents

Receipt Control	4	Expanded programming	25
Meaning of the symbols	4	Fix stages	25
Hints for usage	4	Discharge time	26
Product description	5	Disconnection pause	26
Intended use	5	Power station service	27
Data protection	5	Stage power	28
Hints for maintenance	5	Choke degree	28
Repairing and calibration	5	Voltage transformer ratio	29
Front foil	5	Harmonic thresholds	30
Waste management	5	Switching frequency	31
Funktional description	6	Alarm output	32
Measurement	6	Alarm call	32
Switching of capacitor stages	6	Give a receipt for alarms	32
Switching outputs	6	Lower voltage (1)	33
Net return	6	Overvoltage (2)	33
Hints for installation	8	Underscoring of the measurement current (3)	33
Mounting place	8	Exceeding of measuring current (4)	33
Measurement and supply voltage	8	Insufficient capacitor output (5)	33
Sum current measurement	9	Supply of real power (6)	33
Current measurement	9	Harmonic thresholds (7)	33
Installation and putting into service	10	Overtemperature (8)	33
Measurement and supply voltage	10	Averaging time for the mean value $\cos(\phi)$	34
Current measurement	11	Averaging time of reactive power	34
Real power	11	Ventilator control	35
Switching outputs	12	Ventilation control	35
Transistor outputs	12	Upper temperature limit	35
Target- $\cos(\phi)$ changeover	13	Lower temperature limit	35
Alarm output	13	Switching output	35
Check alarm output	13	Overtemperature disconnection	37
RS485 Interface (Option)	14	Upper temperature limit	37
Transmission protocols	14	Lower temperature limit	37
Bus structure	14	Pause time	37
Shielding	14	Indication in manual mode	38
Cable length	14	Password	39
Terminal resistors	14	Program password	39
Removal of errors	15	Enter password	39
Service	16	Change password	39
Display and use	17	Contrast	40
Automatic mode	17	Reset programming	41
Manual mode	17	Connection configuration	42
Key functions	18	Correction angle	42
Standard programming	19	Software release	43
Target $\cos(\phi)$	19	Serial number	43
Current transformer ratio	20	Serial interface (Option)	44
Learning of the configuration	21	Device address	44
Stage power	22	Transmission protocol	44
Stage ratio	22	Baud rate	45
Switching outputs	23	Modbus RTU	45
Delete peak and lowest values	24	Profibus DP V0	45
		Table Modbus	46
		Table Profibus	47

Display overview	48
Measured value indications	48
Display in standard programming	50
Display in expanded programming	51
Configuration data	53
Setting range	53
Manufacturer's presetting	53
Technical data	54
Ambient conditions	54
Inputs and outputs	54
Measurement	54
Measurement accuracy	54
Back Side	55
Side view	55
Short manual	56

Issue Note

30.06.1999	First edition
21.07.1999	Indication $\cos(\phi)=0.00$; Switching of fixed stages.
12.08.1999	Measurement accuracy, switching frequency.
30.08.1999	Page 30, table of correction angle changed.
31.08.1999	Fuses and connection diagrams have been corrected.
12.11.1999	Switching in manual mode
23.03.2000	Maximum and minimum storage all 15 minutes.
21.09.2000	Functional expansion.
19.01.2001	Technical data and brief instructions added.
20.03.2001	Generator mode = oFF.
04.04.2001	RS485 interface.
22.10.2001	Serial interface does not work at 50Hz switching frequency.
28.01.2002	Connection diagrams alarm output.
12.08.2002	Address list Modbus expanded by harmonics U/I.
22.08.2002	Description of password programming.
23.09.2002	Measurement and supply voltage L-N.

All rights reserved. No part of this manual may be reproduced or duplicated without the written permission of the author. Any contraventions are punishable and will be prosecuted with all legal means.

No liability can be taken for the faultless condition of the manual or damage caused by the use of it. As failures cannot be avoided completely, we shall be very grateful for any advice. We will try to remove any failures as soon as possible. The mentioned software and hardware descriptions are registered trademarks in the most cases and are subjected to the regulations by law. All registered trademarks are property of the corresponding companies and are fully recognized by us.

Receipt Control

In order to ensure a perfect and safe use of the device, a proper transport, expert storage, erection and mounting and careful usage and maintenance are required. When it may be supposed, that a safe operation is no longer possible, the device has to be put out of service and be protected against unintentional putting into service.

A safe operation can no longer be assumed, when the device

- shows visible damage,
- does not work in spite of intact net supply,
- has been exposed to disadvantageous conditions for a longer time (e.g. storage out of the allowed climate without adaption to the room climate, dew etc.) or transport use (e.g. falling from great height, even without visible damage).

Please test the contents of delivery for completion, before starting the installation of the device. All delivered options are listed on the delivery papers.

In the attached description doc. no.: 1.020.030.x all delivery types and options for the reactive power controller Prophi are listed.



Attention!

This manual also describes options and types, which were not delivered and therefore, do not belong to the contents of delivery.

Hints for usage

Safe and failure free operation can only be granted, when the device is operated according to this manual!

This device may be put into service and used by qualified personnel according to the safety regulations and instructions only. Please mind the additional legal and safety regulations for the respective application.

Qualified personnel are persons, familiar with erection, mounting, putting into service and usage of the product and having the qualifications such as:

- education or instruction / entitlement to switch, release, ground or characterize current circuits and devices according to the standards of safety techniques.
- education or instruction in the care and usage of suitable safety equipment according to the standards of safety techniques.

Meaning of the symbols



Warning of dangerous electrical voltage.



This symbol shall warn you of possible dangers, which can occur during maintenance, putting into service and while usage.



Protective wire connection

Product description

Intended use

The reactive power controller Prophi together with external capacitor stages, serves for step by step controlling of the phase shift angle $\cos(\phi)$ in 50/60Hz low voltage networks. Depending on the type of the reactive power controllers Prophi, contactors or semi conductor switches can be controlled directly.

Additionally, the following electrical quantities are measured and indicated:

- Voltage L2-L3,
- Current in L1,
- Frequency,
- Sum real power (Consumption/supply),
- Sum reactive power (ind./cap.),
- uneven current harmonic waves 1. - 19. in %,
- uneven voltage harmonic waves 1. - 19. in %.

The harmonic contents are related to the rated voltage or rated current.

The connection is carried out on the back side via touch proof spring power terminals.

Measurement and supply voltage are taken from the measurement voltage and must be connected to the building installation via a separation (switch or power switch) and an overcurrent protection (6,3A).

The current measurement is carried out via a $\dots/5A$ or $\dots/1A$ current transformer in one outer conductor.

The relay outputs are suitable for contactor control, the transistor outputs are provided for the control of fast switching thyristor modules, switching at zero crossing.

Hints for maintenance

Before delivery the device is tested in various safety checks and marked with a seal. If the device is opened, these checks must be repeated.

There is no guarantee for devices, which are opened out of the manufacturing works.

Repairing and calibration

Repairing and calibration work can be carried out in the manufacturing works only.

Front foil

The cleaning of the front foil must be done with a soft cloth using a common cleansing agent. Acid or acidic agents may not be used for cleaning.

Waste management

The device can be disposed as electronical waste according to the legal regulations and recycled.

Data protection

The data protection is carried out in a none volatile memory (EEPROM).

Changed programming data are saved immediately.

Funktional description

Measurement

The measurement is suited for 3 phase systems with or without neutral conductor for frequencies of 50Hz or 60Hz. The electrical measurement system records and digitalizes the effective values of voltage between L2 and L3 (L-N Option) and the current in L1.

In each second several snap check measurements are carried out. As the current is only measured in one outer conductor, and the voltage only between two outer conductors, the measured values, which are related to all three outer conductors, are exact for equal loaded outer conductors only.

The following electrical quantities are calculated:

- Current and current harmonics
- Voltage and voltage harmonics
- Real power, sum
- Apparent power, sum
- Reactive power, sum
- Reactive power for each stage
- Reactive current for each stage
- Cos(phi),
- Net frequency.

The following information can be indicated:

- Number of switchings of each stage,
- total connection time of each stage and
- the inner temperature.

Prophi measures the frequency of the measurement and supply voltage and shows the average over 10 seconds.

Switching of capacitor stages

Prophi calculates the required reactive power to reach the set target-cos(phi) from the current from one outer conductor and the voltage between two outer conductors. If the cos(phi) deviates from target cos(phi), external capacitor stages or transistor outputs are switched on or off.

In automatic mode the capacitor stages are switched in or off, when the required reactive power is higher or equal to the smallest stage power.

If the power of the first capacitor stage is three times as high as the measured real power, all capacitor stages are switched off.

Switching outputs

Depending on the variety of Prophi, relay or transistor outputs serve as switching outputs.

The relay outputs are suitable for controlling contactors and the transistor outputs can switch thyristor modules, that switch in zero crossing of voltage.

For relay outputs the time between two connections or disconnections is set to two seconds. Transistor outputs have no limitation of the switching period.

Net return

After net return, the set discharge time runs for the relay outputs. The transistor outputs do not mention the discharge time.

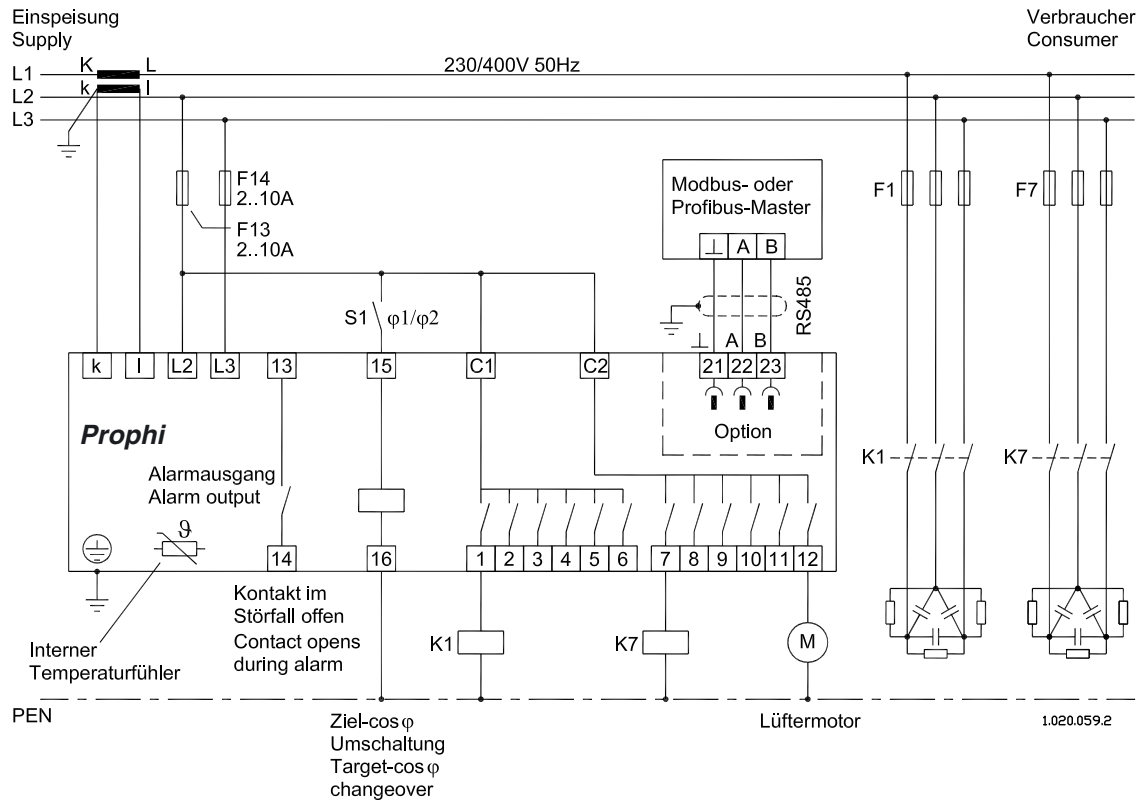

Diagr.: Connection example, power factor controller with measurement and supply voltage L2-L3, 12 relays outputs, target cos(phi) changeover and alarm output.

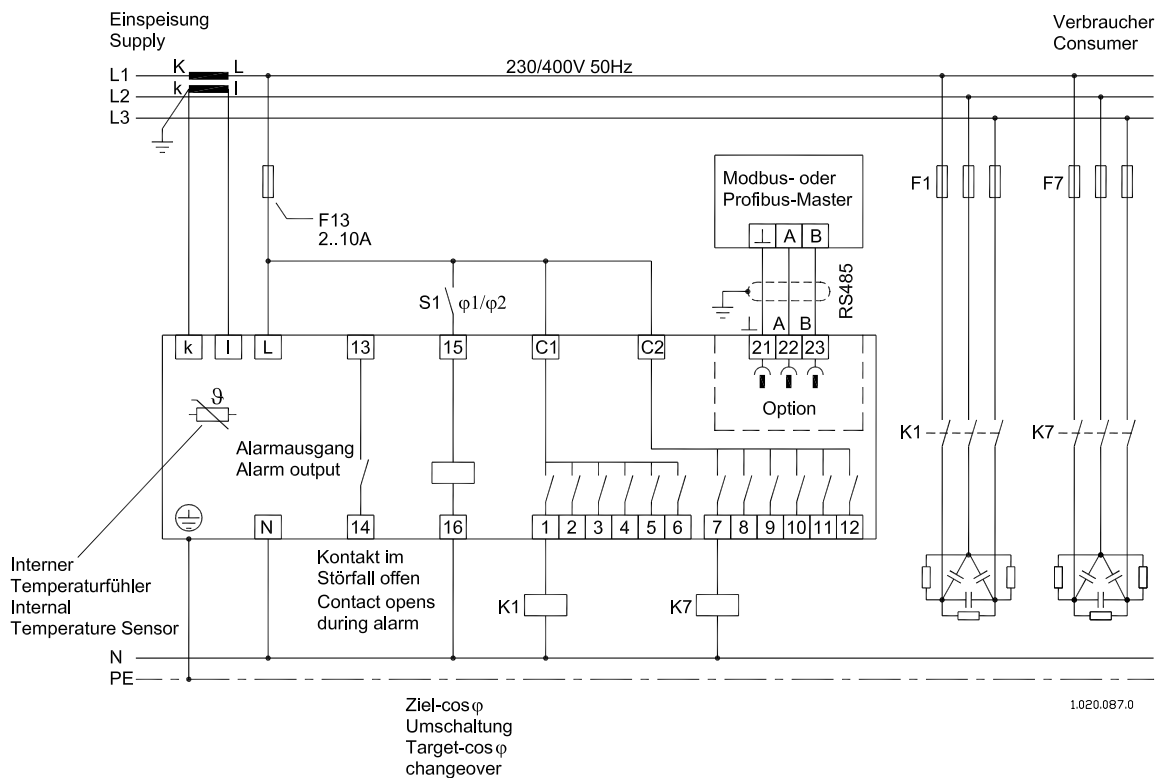

Diagr.: Connection example, power factor controller with measurement and supply voltage L-N, 12 relays outputs, target cos(phi) changeover and alarm output.

Hints for installation

Mounting place

The reactive power controller Prophi is suited for mounting and operation in reactive power compensation systems.

The connection is carried out on the back side via touch proof spring terminals.

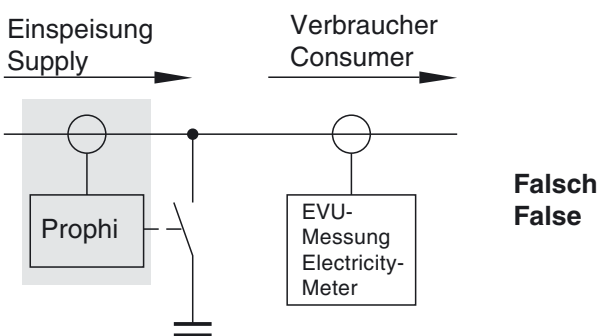
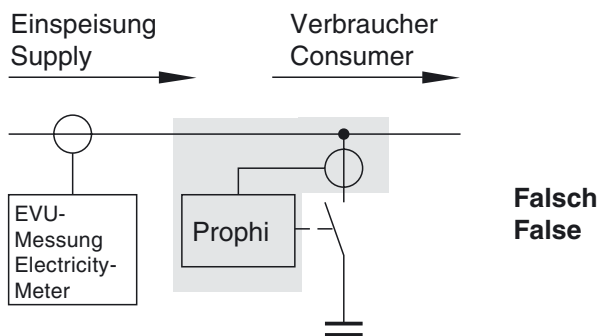
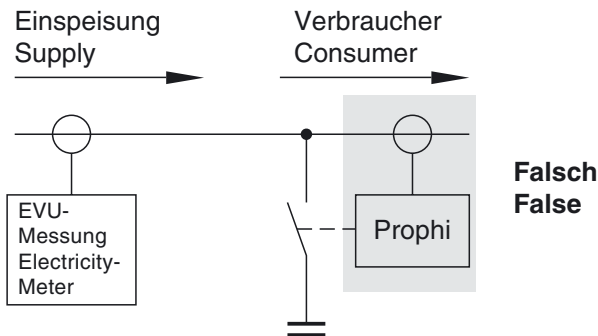
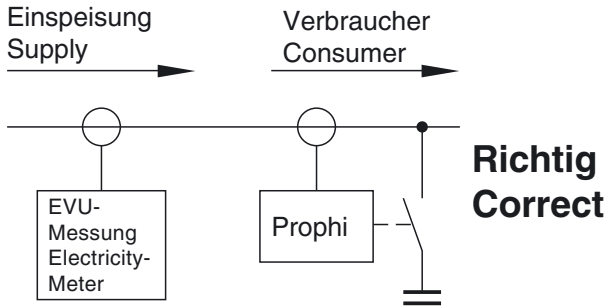

Measurement and supply voltage

The measurement is suited for 3 phase systems with or without neutral conductor. Measurement and supply voltage are taken from the measurement voltage and must be connected to the building installation via a separation (switch or power switch) and an overcurrent protection (2A...10A).



Attention!

The operating voltage for the contactors should be taken from an outer conductor connected to the reactive power controller.

The reactive power controller measures and supervises the voltage between two outer conductors. If one of those two fails, the reactive power controller gets no more measurement and operating voltage, and switches on the capacitive stages after net return according to the programmed times.

If the third outer conductor is missing, this will not be recognized by the reactive power controller. If the contactors are supplied by this outer conductor, the contactors can attract simultaneously and without consideration of the discharge time after net return.



Abb.: Anschluss der Mess- und Hilfsspannung zwischen L2-L3 und der Strommessung über Stromwandlers.



Abb.: Anschluss der Mess- und Hilfsspannung zwischen L1-N und der Strommessung über Stromwandlers.

Sum current measurement

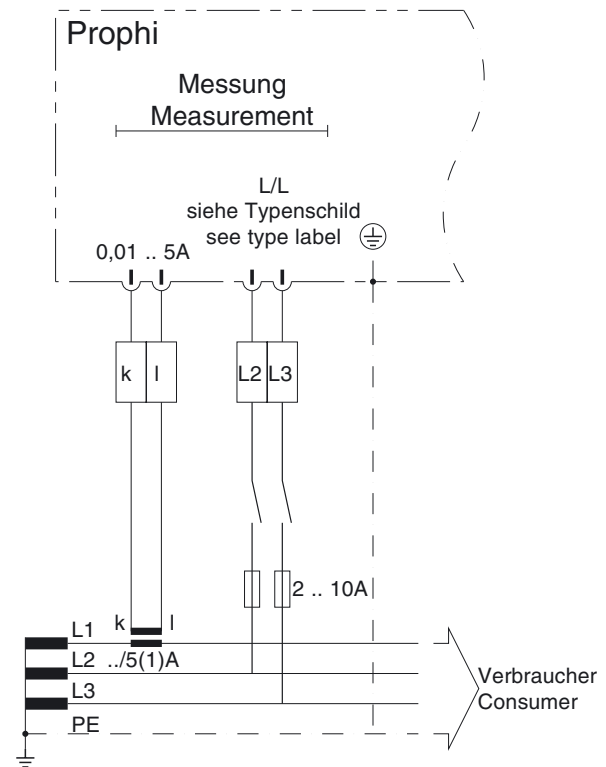
If Prophi is connected to a sum current transformer, the total transformation ratio must be programmed.

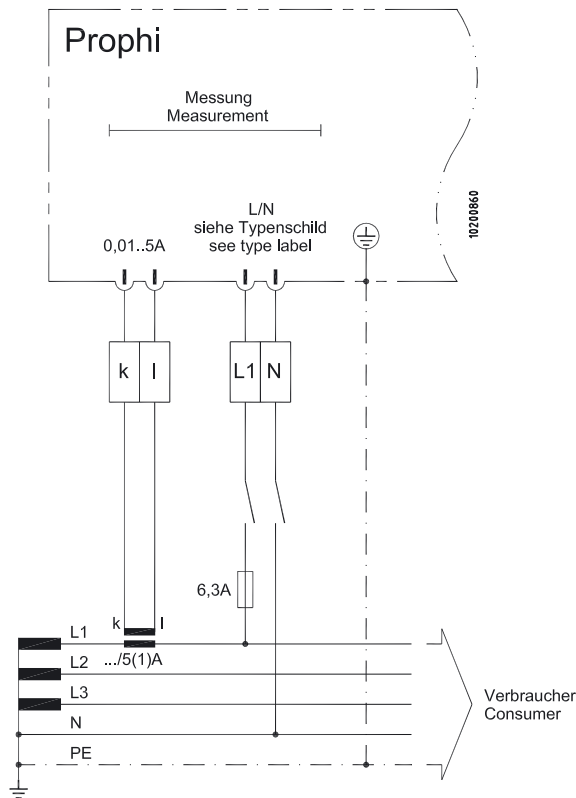
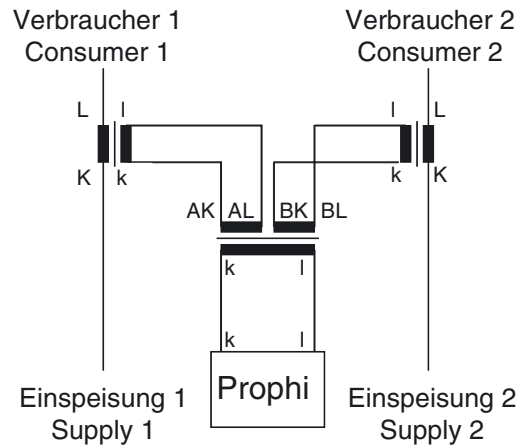

Diagr. Measurement via sum current transformers



Attention!

For unequal load of the outer conductors, the current should be measured in the outer conductor, which is loaded most heavily.

Current measurement

The current measurement is carried out via $\dots/5A$ or $\dots/1A$ current transformers.

If the current must be measured with an Amperemeter additionally to Prophi, it must be connected in series.

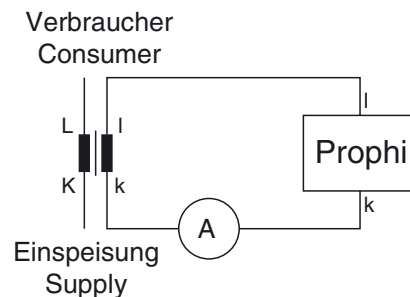

Diagr. Measurement with Amperemeter in series

Installation and putting into service

Measurement and supply voltage

The controller Prophi can be delivered in two connection varieties for the measurement and supply voltage. In the version **measurement L-L**, the measurement and supply voltage must be taken from two outer conductors. In version **measurement L-N**, the measurement and supply voltage must be taken between outer conductor L and neutral N.

Before connection, please ensure, that the local net conditions match the data on type plate. The range of the measurement and supply voltage is given by the type plate and is connected via a fuse (2...10A, time lag type)



Attention!

The measurement and supply voltage must come from the low voltage net, which is supervised.

The connected measurement and supply voltage may not exceed the voltage, mentioned on type plate for more than 10% or underscore for more than 15%. To ensure, that the connected measurement and supply voltage is within the allowed range, please check the voltage at the terminal with a voltmeter.



Attention!

Voltage, which is out of the indicated range on type plate can destroy the instrument.

If the measurement and supply voltage is within the allowed range, Prophi indicates the voltage on the terminal.

While measuring via voltage transformers, the voltage transformer ratio must be programmed.



Attention!

The operating voltage for the contactors should be received from an outer conductor connected to the controller.

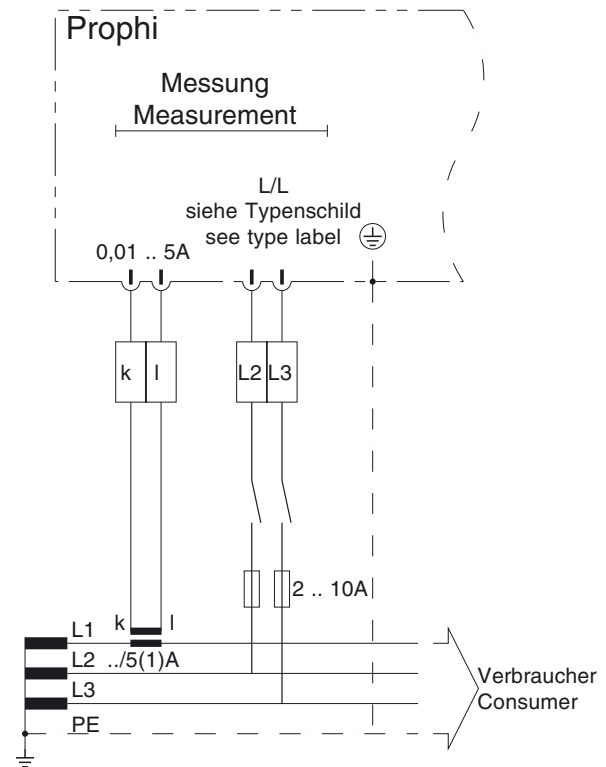

Diagr.: Connection of measurement and supply voltage (L2-L3) and current transformer.

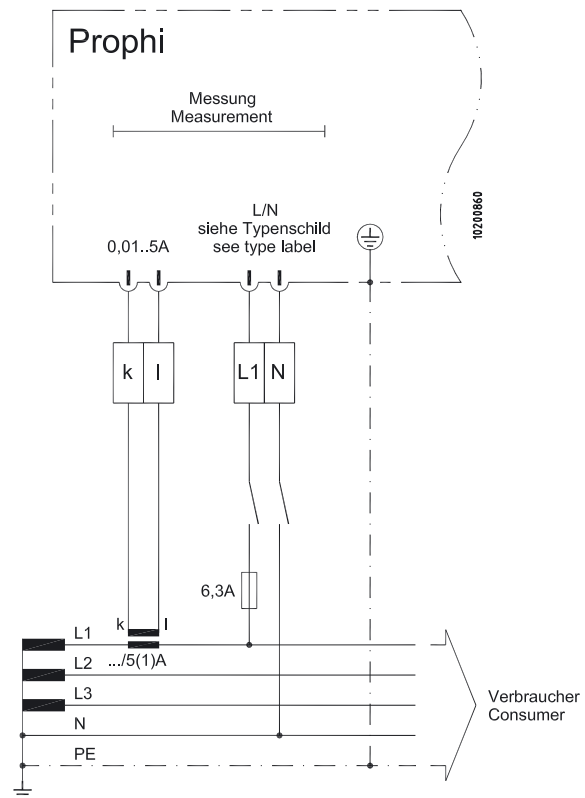

Diagr.: Connection of measurement and supply voltage (L1-N) and current transformer.

Current measurement

The current transformer is connected to the clamps k and l (/5A or /1A) from the outer conductor L1.

Please ensure during the installation of the current transformer, that the current transformer is passed by the consumer current but not by the compensation current.

The current can be measured by an Amperemeter to compare it with the current indicated by Prophi to check. Please note, that the factory's presettings of the current transformer ratio is set to 10 and must be adapted to the existing current transformer.

If you should short-circuit the current transformer, the indicated value on Prophi must decrease to 0A.

Examples for the setting of the current transformer

Example 1

Current transformer	200A/5A
Set Prophi to	40

Example 2

Current transformer	500A/1A
Set Prophi to	500

Example 3

Sum current transformer	1000A+1000A/1A
Set Prophi to	2000

Real power

If current and voltage are connected to Prophi according to the connection diagram, a positive real power is displayed in case of real power consumption. Real power with a negative sign in the indication points to the supply of real power or an error of connection.

Possible error:

- Voltage and current are measured in the wrong outer conductor.
- The current transformer clamps (k-l) are exchanged.



Attention!

For unequal load of the outer conductors, the current should be measured in the outer conductor, which is loaded most heavily.



Attention!

None earthed current transformer clamps can be live.

Switching outputs

The reactive power controller Prophi can be equipped with up to 12 switching outputs. The switching outputs can be equipped either with relay or transistor outputs. If a device is equipped with relay or transistor outputs it is not shown on display. The equipment can be seen in the connection diagram on the back of Prophi.

Relay outputs

Capacitor contactors can be connected to the relay outputs according to the connection example "Relay outputs".

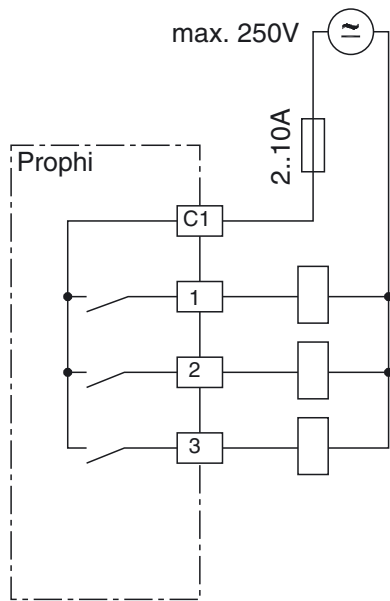

Diagr.: Connection example "Relay outputs"



Attention !

For devices with relay or transistor outputs, there are different control voltages applied to the switching outputs.



Attention!

The relai and transistor outputs are live.



Attention!

If a switching frequency of 50Hz is programmed for the transistor outputs, the serial interface does not work!

Transistor outputs

Semi conductor switches, switching at zero crossing, must be connected to the transistor outputs of the reactive power controller.

The transistor outputs switch the voltage of an external d.c. net supply to the semiconductor switches.

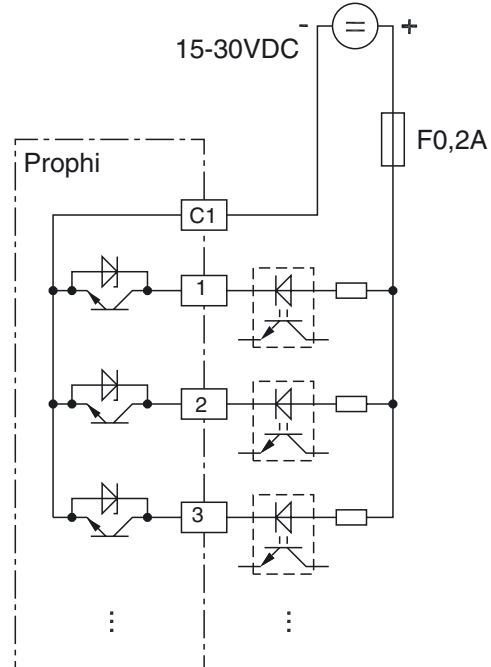

Diagr.: Connection example "Transistor outputs"

Check switching outputs

Please switch in the capacitor stages in manual mode:

The inductive reactive power is decreased by the power of the respective capacitor stage.

Please switch off the capacitor stages in manual mode:

The inductive reactive power is increased by the power of the respective capacitor stage.

Possibility of errors:

The outputs do not switch

- Relay output defective.
- Transistor output defective.

The change of the reactive power is faulty

- The current is measured incorrectly.
- A wrong current transformer ratio is set.
- The current is measured in the wrong outer conductor.
- The voltage is measured in the wrong outer conductors.
- The current transformer clamps k-l are exchanged.

The reactive power does not change

- The current transformer is installed at the wrong place.
- Switching outputs faulty.
- The wrong control voltage is connected to the switching outputs.

Target-cos(phi) changeover

Via the input *target-cos(phi) changeover* it can be changed over between *target-cos(phi1)* and *target-cos(phi2)*.

If there is no voltage at the input, the *target-cos(phi1)* is active. If there is a 85 bis 265V AC connected to the input, the *target-cos(phi2)* is active.

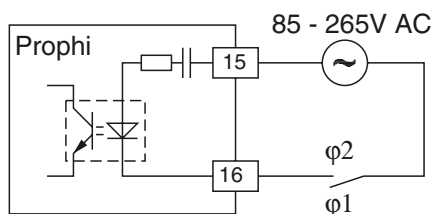

Diagr.: Connection diagram target-cos(phi) changeover

In the standard display (please see example), apart from the active channels and the actual cos(phi) also the active target-cos(phi) is indicated.

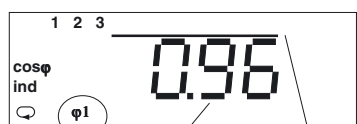

Target-cos(phi1) is active. Actual cos(phi) mean value



Target-cos(phi2) is active. Actual cos(phi) mean value

Alarm output

The alarm relay attracts in undisturbed operation, and the contact of the alarm output is closed. If a disturbance occurs, the alarm relay releases and the contact is opened. Various events can be assigned to the alarm output via OR-logic interconnections. Each event is assigned to an alarm number, an alarm delay and alarm duration.

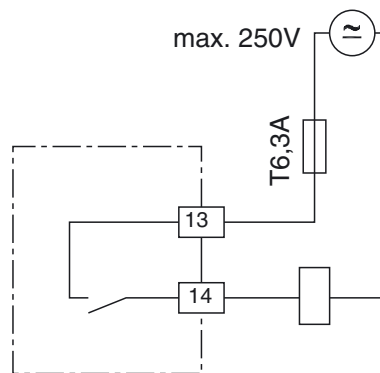

Diagr.: Connection diagram alarm output

Check alarm output

If there is no alarm, the alarm relay attracts immediately. In order to trigger off an alarm, the threshold for overtemperature can be set to zero, for instance, and the alarm relay releases immediately.



RS485 Interface (Option)

Transmission protocols

Two transmission protocols are available for the connection to an existing field bus system:

- 0 - Modbus RTU (Slave) and
- 1 - Profibus DP V0 (Slave) .

With Modbus protocol you can have access to the data of table 1, and with Profibus protocol you can have access to the data of table 2.

Bus structure

All devices are connected in bus structure (line). In one segment up to 32 participants can be assembled. At the end and the beginning of each segment, the cable must be terminated by resistors. In **Prophi** you can activate these resistors with two plug-ins.

For more than 32 participants you must use a repeater (line amplifier) to connect the single segments.

Shielding

For connections via RS485 interface, you need a protected and twisted cable. To achieve a sufficient protection result, the shielding must be connected at both ends extensively to the housing or parts of the cabinet.

Cable specifications

The maximum cable length depends on cable type and transmission speed. We recommend cable type A.

Cable parameter	Type A	Typ B
Impedance	135-165Ohm (f = 3-20MHz)	100-130Ohm (f > 100kHz)
Capacity	< 30pF/m	< 60pF/m
Resistance	< 110 Ohm/km	-
Diameter	>= 0,34mm2 (AWG22)	>= 0,22mm2 (AWG24)

Cable length

The following table shows the maximum cable length in meters (m) for various transmission speed

Cable type	Baud rate (kbit/s)					
	9.6	19.2	93.75	187.5	500	1500
Type A	1200	1200	1200	1000	400	200
Type B	1200	1200	1200	600	200	70

Terminal resistors

If **Prophi** is connected to the end of the bus cable, the bus cable must be terminated at this point with resistors. The required resistors are integrated within the **Prophi** and are activated in position ON.

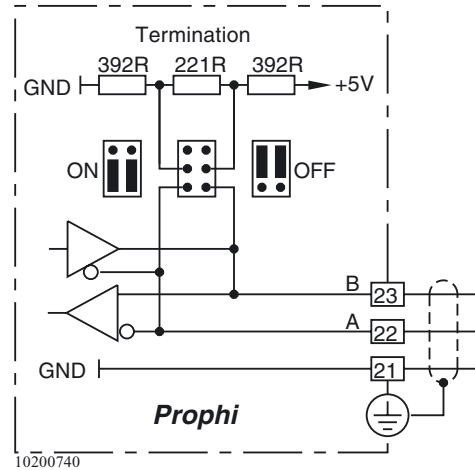

Diagr. Connection RS485 interface

Removal of errors

Description of the error	Possible cause	Remedy
No indication.	<ul style="list-style-type: none"> - Wrong measurement and supply voltage connected. - Prefuse (10A time-lag type) has triggered. 	Please check measurement and supply voltage.
Current too little / too high.	<ul style="list-style-type: none"> - Current measurement in the wrong outer conductor. - Wrong current transformer ratio. - Current out of measuring range. - Current transformer clamps are bridged. - One current transformer line is interrupted. - A current measuring device is connected parallelly. - Wrong voltage transformer ratio. 	Please check current measurement.
Voltage L2-L3 too little / too high.	<ul style="list-style-type: none"> - Uneven load of the outer conductors. - Wrong voltage transformer ratio. 	Please check voltage measurement.
Real power too little / too high.	<ul style="list-style-type: none"> - Voltage and/or current are measured incorrectly. - Voltage and current are measured in the wrong outer conductors. 	Please check current and voltage measurement.
Real power supply/consumption exchanged.	<ul style="list-style-type: none"> - Voltage and/or current are measured incorrectly. - The current transformer connection (k-l) is exchanged. 	Please check current and voltage measurement.
Cos(phi) = 0.00	<ul style="list-style-type: none"> The measuring current is smaller but 10mA. The measuring voltage is interrupted. The current transformer clamps are bridged. 	Please check current measurement.
Cos(phi) too high / too little.	<ul style="list-style-type: none"> - Voltage is measured incorrectly. - Current is measured incorrectly. - Real power is measured incorrectly. 	Please check current and voltage measurement.
Cos(phi) does not change, although all capacitor stages were switched in.	<ul style="list-style-type: none"> The current transformer is installed after the measurement of the energy supplier. 	Check and correct connection. (Please see hints for installation)
Cos(phi) is indicated capacitive on Prophi, but, nevertheless, the reactive power meter measures reactive power.	<ul style="list-style-type: none"> Current and voltage are connected incorrectly. 	Check and correct connection. (Please see hints for installation)
Prophi only connects stages, but does not disconnect.	<ul style="list-style-type: none"> The capacitor current is not detected by the current transformer. Capacitive stages are faulty. 	Check and correct mounting position of the current transformer. Check capacitive stages.
The outputs can only be disconnected.	<ul style="list-style-type: none"> The measurement and operating voltage is exceeded by more than 10%. 	Check measurement and operating voltage.
Prophi shows a cos(phi) of 0,2 - 0,4 capacitive.	<ul style="list-style-type: none"> Current measurement in wrong phase. L1 and L3 are exchanged. 	Check measurement and operating voltage.
It does not work.	<ul style="list-style-type: none"> The device is defective. 	Send the device to the manufacturer with an exact description of the error.

Service

If certain questions appear, which are not mentioned in this handbook, please call us directly.

To be able to support you, we require the following information:

- Device description (see type plate),
- Serial number (see type plate),
- Software Release,
- Measurement and supply voltage and
- Exact description of the error.

You can reach us:

Monday to Thursday from 07:00 to 15:00

and on Friday from 07:00 to 12:00

Janitza electronics GmbH

Vor dem Polstück 1

D-35633 Lahnau

Support:

Tel. (0 64 41) 9642-22

Fax (0 64 41) 9642-30

e-mail: info@janitza.de

Display and use

In the front side of Prophi there is a digital indication and three keys, with which you can question data and program the device.

If you are in automatic mode, you can change between the operating modes using key 1:

- automatic mode,
- manual mode,
- standard programming and
- expanded programming

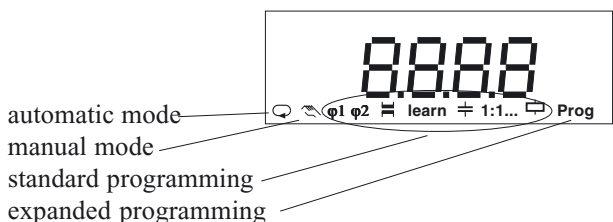

In standard programming often needed settings are carried out such as current transformer ratio or the number of stages.

In expanded programming those settings are carried out, which are used not as often, such as discharge time or choke degree.

To reach the expanded programming from automatic mode, leaf through the standard programming using key 1 until the symbol "Prog" appears. Confirm selection with key 2, and you are in expanded programming.

Automatic mode

Automatic mode is marked by the symbol .

In automatic mode, there is:

- the switching condition of capacitive stages,
- the actual value of $\cos(\phi)$ indicated,
- Connection and disconnection of capacitive stages,
- all 15 minutes saving of peak and lowest values, number of switchings of the capacitor stages and the switching times of capacitor stages.
- Indication of measured values using key 2 and 3.

There are three possibilities to reach automatic mode:

- after net return,
- pressing key 1 for about 2 seconds,
- pressing no key in programming mode for 1

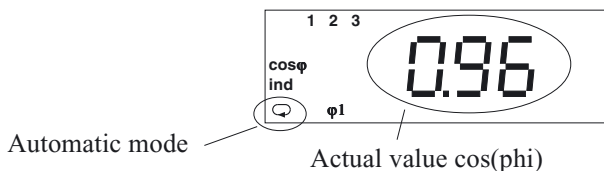

Manual mode







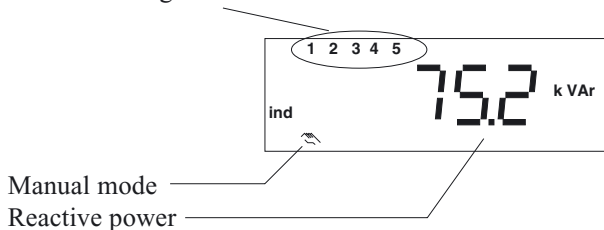









In manual mode, you can switch in capacitor stages using key 3, and switch off capacitor stages using key 2. The time between two switchings is only limited by the programmed discharge time. If one stage shall be connected in manual mode and a discharge time is running, the number and capacitor stage is flashing.

If no capacitors are switched in manual mode, an automatic jumpback to automatic mode is carried out after 15 minutes.

Connected stages



Key functions

	Automatic mode	Manual mode		
		Standard programming	Expanded programming	
Change mode	<p>↻</p> <p>short  → Password</p> <p>←  2 seconds</p> <p>←  → C. In_{Prog}</p> <p>←  2 seconds</p>			
Leaf	<p>long ↑ Meas. values</p> <p> Meas. values</p> <p>short ↓ Meas. values Meas. values</p> <p>← long  short →</p>		<p>Programming Menue</p> <p> Programming Menue</p> <p>short ↓ Programming Menue</p>	<p>long ↑ Programming Menue</p> <p> Programming Menue</p> <p>short ↓ Programming Menue</p>
Programming			<p>Programming Menue</p> <p> Confirm selection</p> <p> Select number</p> <p>8</p> <p> short number +1 long number -1</p> <p>8888</p> <p> short value *10 long value /10</p>	<p>Programming Menue</p> <p> Confirm selection</p> <p> Select number</p> <p>8</p> <p> short number +1 long number -1</p> <p>8888</p> <p> short value *10 long value /10</p>

Standard programming

In the standard programming, the settings needed frequently are carried out, such as:

- target-cos(phi1),
- target-cos(phi2),
- current transformer ratio,
- learning of configuration,
- power of the first capacitive stage,
- stage ratio,
- number of stages,
- delete peak values (no indication).

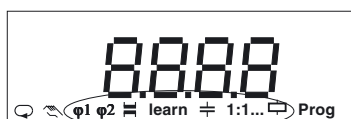

Standard-Programming

In delivery condition no password is programmed. The change from automatic mode into standard programming is carried out without password protection.

If a password is programmed by the user, the change from automatic mode to standard programming is carried out only after password clearance.

Change from automatic mode to standard programming and back:

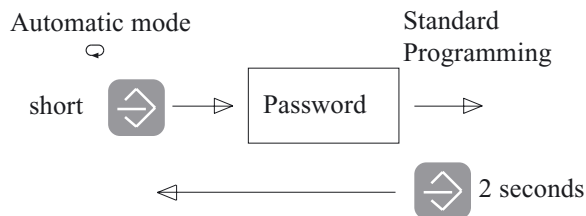

Target cos(phi)

In automatic mode Prophi tries to reach the set target power factor by switching in or off the capacitor stages.

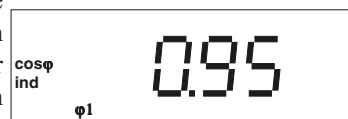

It is possible to set a target-cos(phi1) and a target-cos(phi2). Devices without target-cos(phi) changeover always use the target-cos(phi1). Devices with an input for target-cos(phi) changeover switch to target-cos(phi2), whenever the input is active.

Range 0.80cap. - 1.00 - 0.80ind.

The active target-cos(phi) is indicated in the measured value indication for the actual-cos(phi).

Example:

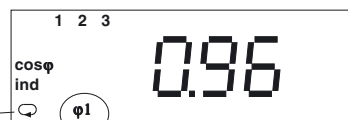

Automatic mode

Target-cos(phi1) is active.

Programming

Press key for about 2 seconds to select automatic mode.

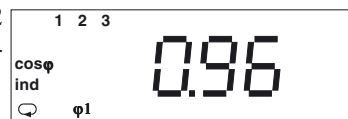

Automatic mode

Press key 1 to leaf to manual mode until indication target cos(phi).



Manual mode

Select the number to be changed using key 2. The selected number flashes. Change the selected number by pressing key 3.

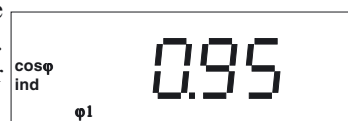

Target cos(phi1)

Press key 1 for about 2 seconds. You return to automatic mode, and the changes are saved immediately.

Current transformer ratio

At the measuring input of the current measurement either / 5A or /1A current transformers can be



connected. In order to get a correct current and power indication, the current transformer ratio of the connected current transformer must be set to Prophi. If the current is measured via a sum current transformer, the total current transformer ratio must be set.

Example 1: Current transformer 500A/5A

The current transformer ratio is now calculated to

$$500A : 5A = 100$$

A ratio of 100 must be set on the device.

Example 2: Current transformer 200A/1A

The current transformer ratio is calculated to

$$200A : 1A = 200$$

A ratio of 200 must be set on the device.

Example 3: Sum current transformer

Transformer 1 200/5A

Transformer 2 400/5A

Sum current transformer 5+5/5A

The current transformer ratio is calculated to

$$(200A + 400A) : 5A$$

$$600A : 5A = 120$$

Programming

Example: Current transformer ratio 1000

Select indication for current transformer ratio using key 1.

The automatic symbol disappears.

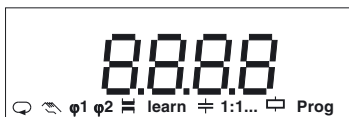

CT ratio

Automatic mode

Select the digit to be changed. The selected digit is flashing.

Change the selected digit pressing key 3.



Current transformer ratios of more but 1000 are indicated with a decimal point automatically.

Example: Current transformer ratio = 1200

$$1200 = 1.200k$$

Indication on display "1.200k"

Learning of the configuration

After installation of the controller there is the possibility to learn and save the configuration with the function "learn".



Important requirements are:

- The discharge time for capacitors is set to 60 seconds, when the device is delivered. For capacitors with longer discharge times, **the discharge time must be checked and changed before using the "learn" function.**
- The current transformer must be flown through by consumer and compensation current.
- The measurement and supply voltage may not be taken from phase to N.
- The compensation system must be ready for operation.

The learning function of the controller is divided into two steps:

Step 1 - Learning of the connection configuration

Here the correction angle between current transformer and measurement and supply voltage is detected.

Step 2 - Learning of the capacitor stages

Here the number of outputs and the stage power of each stage is detected.

The following requirements are necessary:

- The switching of a capacitor stage must cause a change of current of at least 50mA at current input.
- The stage power of the stage to be learned must be bigger than 1% of the measuring range of the controller.

Attention!

After learning, the saved configurations must be checked, if they are plausible.

Attention!

After learning, the saved configurations must be checked, if they are plausible.

The following actions can be carried out:

- oFF - No learning.
- 1 - Step 1, learning of the connection configuration.
- 2 - Step 2, learning of capacitor stages.
- 3 - Step 1 + 2, learning of the connection configuration and capacitor stages.

Start learning

Go to symbol **learn** using key 1.

Select action (oFF, 1, 2, 3) with key 3.

Start learning with key 1.

The symbol **learn** flashes. The controller learns.

During the learning the capacitor stages are switched for several times. The learning can only be interrupted by switching off the power factor controller.

The duration of the learning procedure depends on the net conditions, the number of capacitor stages and the set discharge time for the capacitors.

When the learning procedure is finished, the detected correction angle, in the example 270°, is indicated.

The learned characteristics are saved.

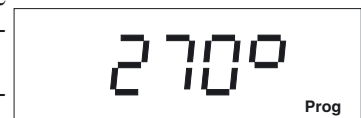
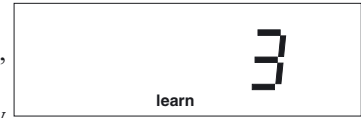

After 60 seconds the controller changes to automatic mode. Pressing key 1 for 2 seconds, you reach automatic mode at once.

Stage power

The stage power is the power of a capacitor stage. In the standard programming the stage power can only be programmed for the first stage. In the expanded programming you can set the stage power for each capacitor stage. If you only enter the stage power for the first capacitor stage, the other stages are fixed by the stage ratio. The stage power of each capacitor stage can be calculated from the first stage and the corresponding stage ratio.



Ratio 0var - 9999kvar

Example 1

Power of the first capacitor stage = 10kvar
 Stage ratio = 1:1:1:1:1....
 All following stages have the power: 10kvar

Example 2

Power of the first capacitor stage = 20kvar
 Stage ratio = 1:2:4:8:8....
 The stages have the power:
 1. Stage = 20kvar
 2. Stage = 40kvar
 3. Stage = 80kvar
 4. Stage = 160kvar
 5. Stage = 160kvar
 etc.

Example: Programming stage power

Please select the indication for stage power using key 1. The automatic symbol disappears.

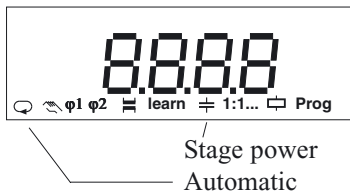

Select the digit to be changed using key 2. The selected digit is flashing. Change the digit by pressing key 3.



If all numbers are flashing, the decimal point of the set number is moved.

Stage ratio

The stage ratio states the ratio of the stage power of the various capacitor stages. The power of the first capacitor stage serves as a reference. The stage ratio is programmable for each stage up to the fifth stage.

Setting range : 0 - 9

In the display only the stage ratio for the capacitor stages 2, 3, 4 and 5 are indicated. The stage ratio for the first capacitor stage is always 1.

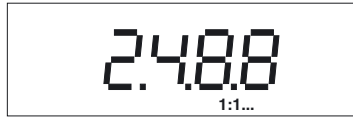

Example 1

The stage ratio is programmed to 1:2:4:8:8..., and in the four digit-display, only the part "2:4:8:8" is indicated.

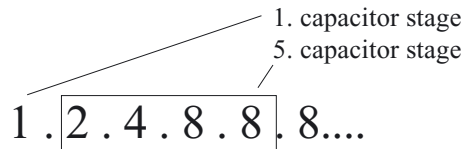

Indicated on display.

Example 2

The stage ratio is programmed to 1:2:0:2:2.... In the 4-digit display only the part "2:0:2:2" is indicated.

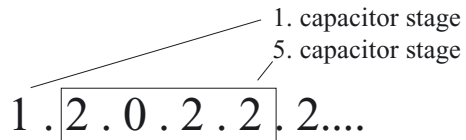

Indicated on display.

If the first capacitor stage has a power of 10kvar, the following stages have the power:

- 1. Stage = 10kvar
- 2. Stage = 20kvar
- 3. Stage = 0kvar**
- 4. Stage = 20kvar
- 5. Stage = 20kvar
- etc.

Example: Programming stage ratio

Please select the indication of the stage ratio using key 1. The automatic symbol disappears.

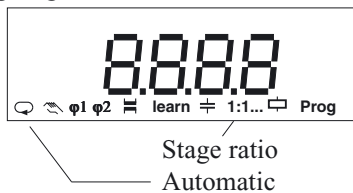

Please select the digit to be changed using key 2. The selected digit is flashing. Change the selected digit by pressing key 3.

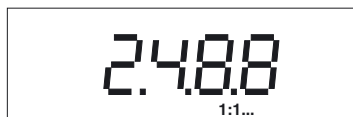

Switching outputs

The reactive power controller Prophi can be equipped with up to 12 switching outputs.



Switching outputs

The switching outputs can be equipped with either relay or transistor outputs.

If a device is equipped with relay or transistor outputs it cannot be read on display. The equipment can only be seen on the back side of Prophi in the connection example.

Prophi is available in three varieties regarding the switching outputs.

1. Only relay outputs
2. Only transistor outputs
3. Relay and transistor outputs mixed

In the menus of the standard programming, only the variations 1 and 2 can be programmed.

In mixed operation the switching outputs with smaller numbers are always the relay outputs.

The relay outputs in mixed operation are programmed in the menu of standard programming, and the transistor outputs are programmed in the menu of expanded programming. The programming of the transistor outputs is carried out indirectly via the stage power of the switching outputs. For transistor outputs, to which no semiconductor switch is connected, a capacitor power of 0kvar is set.

Variety	Switching outputs											
	1	2	3	4	5	6	7	8	9	10	11	12
3R	R	R	R									
3T	T	T	T									
6R	R	R	R	R	R	R						
6T	T	T	T	T	T	T						
6R6T	R	R	R	R	R	R	T	T	T	T	T	T
12R	R	R	R	R	R	R	R	R	R	R	R	R
12T	T	T	T	T	T	T	T	T	T	T	T	T

T= Transistor outputs

R= Relay outputs

Diagr. Varieties of the switching outputs

Example 1: Prophi with 12 relay outputs

10 of the 12 existing outputs shall be engaged.

The programming and indication of the switching outputs is carried out in the menu standard programming.

Please select the indication of the switching outputs using key 1.

The automatic symbol disappears.

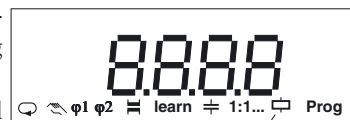

Switching outputs
Automatic

Please select the digit to be changed using key 2. The selected digit is flashing.

Change the selected digit by pressing key 3.



Example 2: Prophi with 3 transistor outputs

Please check, if 3 transistor outputs are programmed.

The programming and indication of the switching outputs is carried out in the menu standard programming.

Please go to the indication of the number of stages.

The automatic symbol disappears.

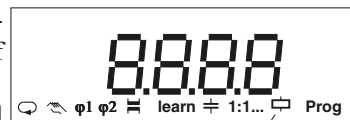

Switching outputs
Automatic

Only two stages are programmed!

Select the digit to be changed using key 2. The selected digit is flashing.

Change the selected digit using key 3.



Example 3: Prophi 6R6T with 6 transistor outputs and 6 relay outputs

Two transistor outputs and 6 relay outputs shall be programmed.

The programming of the relay outputs is carried out in the menu standard programming, and the programming of the transistor outputs is carried out in the menu expanded programming.

1. step: Programming of the relay outputs.

In standard programming you move to the indication of the number of stages using key 1. 6 stages are programmed, so no change is required.



2. step: Programming of the transistor outputs.

The programming of the transistor outputs is carried out in the expanded programming.

Please move to the expanded programming using key 1. Now press key 2.



In the expanded programming appears the menu point "Fix stages".



Using key 3, you reach the indication stage power.



Here the stage (7) is selected by pressing key 2. Please confirm with key 1. One digit for the stage power is flashing.

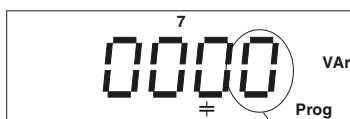

If this stage is engaged, the required stage power must be programmed by pressing the keys 2 and 3.

Select the digit to be changed using key 2. The selected digit is flashing. Now change the digit using key 3.

If all ciphers are flashing, the shown digit can be multiplied by 10 using key 3. Also the dimension of the unit can be changed.

Delete peak and lowest values

Peak and lowest values of various measured values are saved every 15 minutes.



The peak values and lowest values can only be deleted altogether.

The following values are not deleted:

- Peak temperature value,
- Switching time of the capacitor stages and
- Number of switchings per stage.

Example: Delete peak values

Move to indication for peak and lowest values by pressing key 1.



The automatic symbol disappears.



Select delete with key 3. Text "on" is flashing. With key 1 you move to the expanded programming and activate deletion.



Expanded programming

In the expanded programming those settings are carried out, which are required very rarely.



With key 3 you can change between the indications. With key 1 the selected indication can be chosen for changing.

The following settings and readings can be carried out in expanded programming:

- Fix stages,
- Discharge time,
- Disconnection pause of relay stages,
- Power station service,
- Stage power, 1. - 2. stage,
- Choke degree,
- Voltage transformer ratio,
- Harmonic table,
- Switching frequency of transistor stages,
- Alarm calls,
- Averaging time for reactive power,
- Averaging time of the mean value cos(phi),
- Fan control,
- Overtemperature disconnection,
- Indication in manual mode,
- Password,
- Contrast,
- Reset of programming,
- Connection configuration,
- Software release and
- Serial number. Power station service,
- Stage power, 1. - 2. stage,
- Choke degree,
- Voltage transformer ratio,
- Harmonic table,
- Switching frequency of transistor stages,
- Alarm calls,
- Averaging time for reactive power,
- Averaging time of the mean value cos(phi),
- Fan control,
- Overtemperature disconnection,
- Indication in manual mode,
- Password,
- Contrast,
- Reset of programming,
- Connection configuration,
- Software release,
- Serial number and
- RS485 interface.

Fix stages

The first three capacitor stages can be fixed switched in alternatively. Fix stages are marked by a line below the number of the capacitor stage.



Fix stages cannot be included in the controlling. Nevertheless they are considered in the stage ratio, so that in the stage ratio in the most disadvantageous case (three fix stages) in the standard programming only two stage ratios are available. To get a better solution of the stage power, the capacitor power must be set for every single stage in the expanded programming.

Example 1: Indication of stage ratio

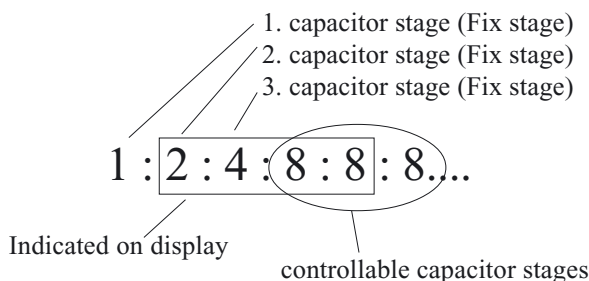

Example 2: Indication of fix stages in automatic mode

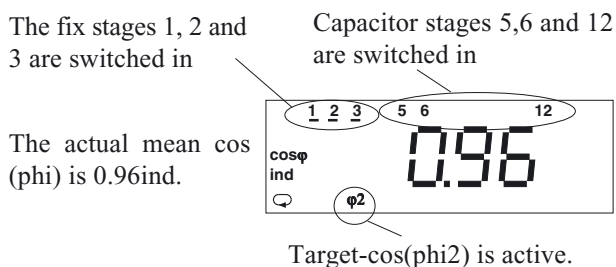

Example: Programming of fix stages

Please select the fix stages by using key 1. The first three stage numbers are flashing.



All three fix stages are switched on.

With key 3 you switch in the fix stages. With key 2 you disconnect the fix stages. Confirm selection with key 1 and continue with expanded programming using key 3.

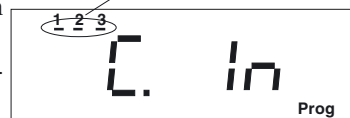

Discharge time

The discharge time means the time, which each capacitor stage has got for discharge.



Setting range : 0 - 1200 seconds

The discharge time will be started after a net return and after switching of a capacitor stage.

Capacitor stages controlled by transistor outputs must not consider the discharge time, as the therewith controlled semiconductor switches in the zero crossing of voltage.

Example: Programming discharge time

With key 3 you can leaf to the discharge time in the expanded programming. With key 1 you get into programming mode. In this example a discharge time of 60 seconds is indicated.

Select the digit to be changed using key 2. The selected digit is flashing.

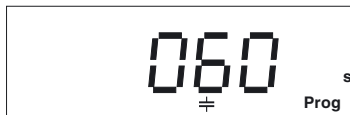

Change digit using key 3.

Pressing key 1 you leave the programming mode and with key 3 you can continue leafing through the expanded programming.

Disconnection pause

The disconnection pause means the time after the connection of a capacitor stage, in which it is forbidden to disconnect the next stage.



Setting range : 0 - 1200 seconds

The disconnection pause is not valid for capacitor stages, switched via transistor outputs.

Example: Programming of disconnection pause

With key 3 you leaf to the disconnection pause in expanded programming. Please press key 1. In this example a disconnection pause of 15 seconds is indicated.

Select the digit to be changed by using key 2. The selected digit is flashing.

Change the selected digit using key 3.



Pressing key 1 you leave the programming mode and with key 3 you can continue leafing through the expanded programming.

Power station service

By setting "power station service" the reaction of the controller at small currents is controlled.

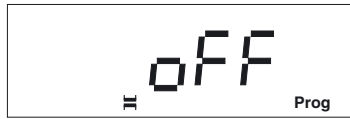

Presetting: Power station service = "oFF"

Power station service= "oFF"

If no or a very small current is flowing through the current transformer, all connected capacitor stages are switched off one after the other.

Power station service = "on"

If delivery (power station service) and consumption is possible, connected stages must remain connected to the net, even if no current is measured.

Programming

Example: Power station service

Go to power station service in expanded programming using key 3.

Confirm selection with key 1.

Text "on" flashes.

Set function "power station service" to "oFF" using key 2 and to "on" using key 3.

Confirm with key 1 and continue with expanded programming pressing key 3.



If real power is generated in a certain application, the following situations can arise:

Case a.

The generated real power is smaller than the demand. Additionally real power is delivered by the energy supplier.

Case b.

The generated real power is bigger than the demand. Real power is supplied.

Case c.

The generated real power corresponds to the demand.

In all cases the required reactive power is supplied by the energy supplier, or even better, by a compensation system.

The following situation can come into being. The needed real power is completely generated (case c.) by the generator, and the reactive power is completely supplied by a compensation system.

There is no current flowing through the current transformer. If the power station service, by mistake, is on "oFF", the capacitor stages are disconnected. Then a reactive current is flowing again through the current transformer. The controller detects a need for compensation, and connects the stages again. The reactive current is compensated. Again, no current is flowing.

The problem is, that the number of switchings is increased.

For power station service, especially in case c, the **power station service should be set to "on"**.

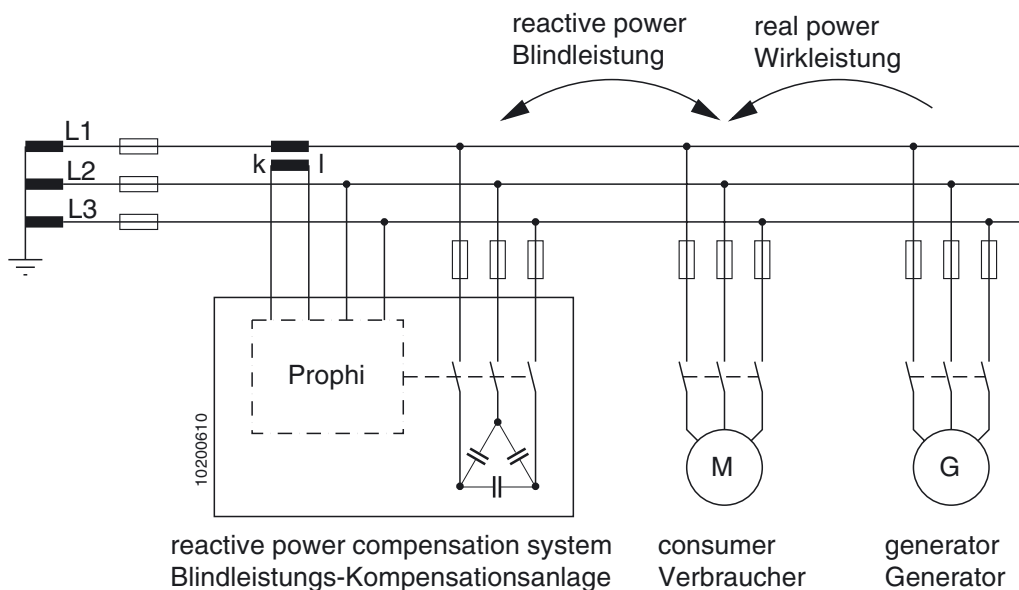

Diagr.: Connection example power station service

Stage power

The stage power is the capacitive reactive power of a capacitor stage. The stage power can be set in the expanded programming for each stage. In the standard programming, the stage ratio 0000 is indicated.

Setting range 0 var - 9999kvar



Example: Programming stage power

With key 3 you can leaf to the stage ratio in expanded programming. Please press key 1 to confirm. In this example, a stage power of 10kvar is indicated for the first capacitor stage.

Select the digit to be changed using key 2. The selected digit is flashing.



Change the selected digit using key 3.

Pressing key 1 you leave the programming mode and with key 3 you can continue leafing through the expanded programming.

Choke degree

The choke degree must be set for choked or combined choked compensation systems. The choke degree is needed

for the exact determination of the capacitor current.

With the choke degree you lay down the switching order in combined choked compensation systems. Capacitor stages with a high choke degree and low choke degree are switched alternately. Capacitor stages with a high choke degree are switched in first.

If more but two different choke degrees are set, the capacitor stages with the middle choke degrees are switched as unchoked capacitor stages.

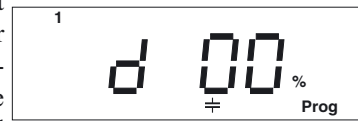

Attention!

To reduce the programming expenditure, the programming of the first capacitor stage is taken over for all the following capacitor stages. Nevertheless, the choke degree can be changed for the following capacitor stages afterwards.

The choke degree is given for each capacitor stage in percent.

Setting range : 0 - 15%

Example: Programming choke degree

Please leaf to the choke degree in the expanded programming using key 3. In this example, for the first stage a choke degree of 5,7% is needed. For the programming, 6% was selected.

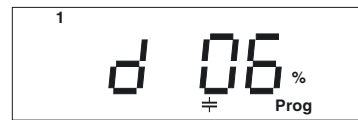

If the choke degree for the second capacitive stage must be programmed, you leaf to the desired capacitor stage pressing key 2.

The selected capacitor stage is confirmed by pressing key 1.

Select the digit to be changed using key 2. The selected digit is flashing.

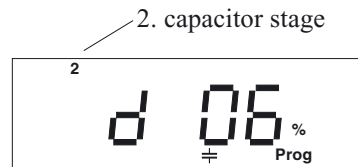

Change the selected digit by pressing key

Pressing key 1 you leave the programming mode and with key 3 you can continue leafing through the expanded programming.

Voltage transformer ratio

If the measurement and operating voltage for Prophi is taken from a voltage transformer, the voltage transformer ratio can be set. This ratio is build by *number 1* and *number 2*.

$$\text{Voltage transformer ratio} = \frac{\text{number 1}}{\text{number 2}}$$

The setting ranges for the *numbers* 1 and 2 are:

- number 1* : 1 - 9.999k
- number 2* : 1, 10, 100, 110, 200, 230, 400

In this example, the presettings are indicated with

- number 1* = 1 and
- number 2* = 1.

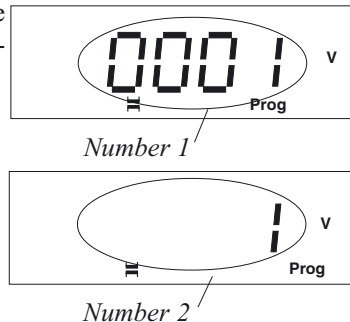

Example: Programming voltage transformer ratio

A voltage transformer has a primary of 20000V and a secondary of 100V.

The result is a ratio of

$$\frac{20000\text{V}}{100\text{V}} = \mathbf{200}$$

The measurement and supply voltage mentioned on type plate of Prophi must be 100V.

To set the ratio of **200**, several combinations of *number 1* and *number 2* are possible.

e.g.
$$\frac{\text{number 1}}{\text{number 2}} = \frac{200}{1} = \mathbf{200}$$

or
$$\frac{\text{number 1}}{\text{number 2}} = \frac{2000}{10} = \mathbf{200}$$

Programming *number 1*

Leaf to *number 1* for voltage transformer ratio in expanded programming using key 3. Confirm with key 1. In this example, *number 1* = 1.



Select the digit to be changed by pressing key 2. The selected digit is flashing.

Change the selected digit using key 3.

With key 1 you can leave programming mode and with key 3 you continue expanded programming.

Number 1 is indicated with a decimal point automatically, when the value gets bigger than 1000.

Example: Voltage transformer ratio = 1200
1200 = 1.200k

Indication "1.200kV"

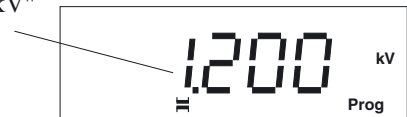

Programming *number 2*

Leaf to *number 1* for voltage transformer ratio in expanded programming using key 3. Change to *number 2* with key 2. In this example a value of 1 is indicated for *number 2*. Confirm selection with key 1.

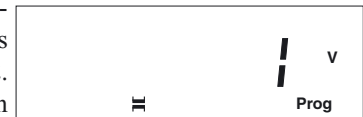

The value flashes.

With key 2 and key 3 the needed value can be selected for *number 2* from a list of values (1, 10, 100, 110, 200, 230, 400).

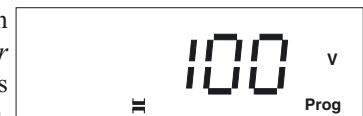

Confirm selection with key 1. The selected value does not flash anymore.

Continue expanded programming with key 3.

Attention! If a wrong voltage transformer ratio is set, all voltage as power is indicated incorrectly.

Harmonic thresholds

In order to avoid resonance in the net and to protect capacitors from overload, a threshold row should be selected



from the threshold table. If a harmonic threshold is exceeded, capacitive stages are switched off for the duration of the discharge time.

Setting range 0 - 10

In order to avoid too much switchings of capacitor stages, the capacitor stages are only switched on, when the harmonic threshold of a lower threshold row is exceeded.

If the threshold row is selected for 0, no capacitor stages are switched off. The thresholds of threshold row 0 are only taken as the lower threshold row for threshold row 1.

Example: Programming threshold row

Leaf to the harmonic table in the expanded programming using key 3. Confirm with key 1. In this example the threshold row 1 is indicated.

Select the digit to be changed by pressing key 2. The selected digit is flashing.

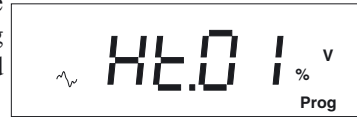

Change the selected digit by pressing key 3.

Pressing key 1 you leave the programming mode and with key 3 you can continue leafing through the expanded programming.

Harmonic thresholds in % of nominal voltage

Harmonic number	Threshold row number									
	1	2	3	4	5	6	7	8	9	10
3.	3.5	4.0	4.5	5.0	5.5	6.0	6.5	7.0	7.5	8.0
5.	4.5	5.0	5.5	6.0	6.5	7.0	7.5	8.0	8.5	9.0
7.	3.5	4.0	4.5	5.0	5.5	6.0	6.5	7.0	7.5	8.0
9.	1.2	1.2	1.5	1.5	2.0	4.0	4.5	5.0	5.5	6.0
11.	2.5	3.0	3.0	3.5	4.0	5.0	5.5	6.0	6.5	7.0
13.	2.0	2.1	2.5	3.0	4.0	5.0	5.5	6.0	6.5	7.0
15.	1.0	1.2	1.5	1.5	1.8	2.0	2.2	2.5	2.0	2.3
17.	1.5	1.5	2.0	2.0	2.3	2.0	2.5	3.0	3.5	4.0
19.	1.0	1.2	1.5	1.5	1.8	2.0	2.2	2.5	3.0	3.5

Switching frequency

The switching frequency determines, how often per second a transistor output may be switched at maximum.

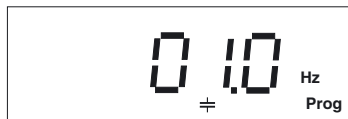

Possible switching frequencies are:

- 0,1Hz, (preset)**
- 0,2Hz,
- 0,5Hz,
- 1,0Hz,
- 10,0Hz and
- 50,0Hz.

The delay time between two switchings of transistor outputs is fixed to a minimum of 70ms, except for "50.0Hz".

Switching frequency 0,1Hz

If a switching frequency of 0,1Hz is set, a transistor output is switched in and off within 10 seconds one time at maximum.

Switching frequency 10Hz

If a switching frequency of 10Hz is set, a transistor output is switched in and off 10 times per second at maximum.

Schaltfrequenz „50,0Hz“

Die Zeit von einer Signaländerung im Netz, bis zum Auslösen einer Schalthandlung am Transistorausgang des Prophi, beträgt maximal 20ms. Die Zeit zwischen zwei Schalthandlungen beträgt minimal 50ms. Wird eine Schaltfrequenz von 50Hz für die Transistorausgänge programmiert, so ist die serielle Schnittstelle außer Funktion.

Example: Programming switching frequency

Go to the switching frequency using key 3 in expanded programming. Change to programming mode with key 1. In this example, a switching frequency of 10,0 Hz is indicated.

The set frequency is flashing.

Now select the needed frequency with key 2 and 3.

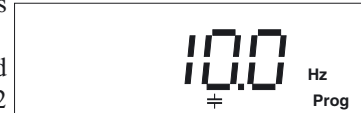

Pressing key 1 you leave the programming mode and with key 3 you can continue leafing through the expanded programming.



Attention!

If a switching frequency of 50Hz is programmed for the transistor outputs, the serial interface does not work!

Alarm output

In undisturbed operation, the alarm relay attracts, and the contact of the alarm output is closed. In case of a disturbance, the alarm relay releases and the contact is opened. Various events can be assigned to the alarm output via or-conjunctions. One alarm number, one alarm delay and one alarm duration are assigned to each event. The alarm call can be activated or deactivated for each event.



"on"/number = Alarm call is activated.
 "oFF" = Alarm call is deactivated.

The following events can be assigned to the alarm output:

Alarm-number	Event	Condition
1	Lower voltage	oFF/number
2	Overvoltage	oFF/number
3	Underscoring of meas.current	oFF/number
4	Exceeding of meas. current	oFF/number
5	Insufficient capacitor output	off/on
6	Supply of real power	off/on
7	Harmonic thresholds	oFF/number
8	Overtemperature	oFF/number

Example: Programming compensation power

Leaf to the first alarm in the expanded programming with key 3. Please leaf to compensation power (5) with key 2 and confirm with key 1.

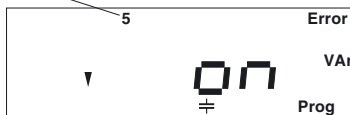

With key 3 the alarm "compensation power" is activated (on), with key 2 the alarm "compensation power" is deactivated (oFF).

Pressing key 1 you leave the programming mode and with key 3 you can continue leafing through the expanded programming.

Alarm call

If one or more alarms occur, Prophi changes to an alarm indication. In the alarm indication, the errors are shown by their number. In the following example, the errors "lower voltage" and "compensation power" occurred. The time and dimension of the error is not saved.

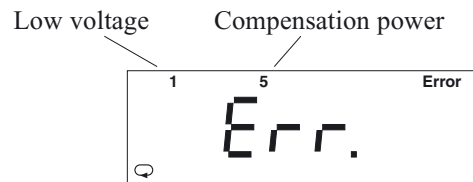

Give a receipt for alarms

If you confirm the alarm message with key 3, you reach the last measured value indication. The error symbol "Error" remains within the measured value indications until the errors are not valid anymore.

Example: Alarm message

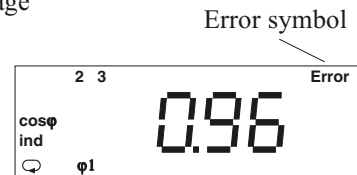

If other error messages appear after the confirmation of an error message, the alarm indication appears again with new error messages. Older errors, which are not valid anymore, are flashing.

Lower voltage (1)

A lower voltage is recognized, when the measurement and supply voltage is smaller or equal to the rated voltage given on type plate.

If lower voltage occurs, it is recognized after 100ms latest, and the alarm output is active for at least 1 minute. The threshold for lower voltage is programmable in 1% steps in the range of 85% and 99%.

Example

Selected threshold : 85%

85% of the rated voltage of 400V make 340V.

If the voltage of 340V is underscored, the alarm relay releases.

Attention!

If the measurement and operating voltage falls below 85% of the rated voltage, all capacitor stages are switched off after about 20ms.

Overvoltage (2)

Overvoltage is recognized, when the measurement and supply voltage is higher or equal to the rated voltage given on type plate.

If overvoltage occurs, this will be recognized after 100ms latest, and the alarm output is active for at least 1 minute.

The threshold for overvoltage can be programmed in the range of 96% up to 110% of the rated voltage in 1% steps.

Example

Selected threshold : 110%

110% of the rated voltage of 400V make 440V.

If the voltage of 440V is exceeded, the alarm relay releases.

Underscoring of the measurement current (3)

The rated current of a measuring input is 5A. If the selected threshold for the measurement current is underscored, after 100ms maximum the alarm relay releases for at least 1 minute.

The threshold for underscoring the measuring current can be programmed in the range of 0% up to 28% of the rated current in 2% steps.

Example

Selected threshold : 10%

10% of the rated current of 5A make 0.5A.

If the current of 0.5A is underscored and the alarm relay releases.

Exceeding of measuring current (4)

The current of current measurement input is 5A. The rated current of the current measuring input is 5A. If the preset threshold for the measurement current is exceeded, the alarm relay releases after 100ms latest for at least 1 minute.

The threshold for exceeding the measurement current can be set in the range of 50% up to 120% of the rated current in 5% steps.

Example 1

Selected threshold : 95%

95% of the rated current 5A make 4.75A.

If the current of 4.75A is exceeded, the alarm relay releases.

Insufficient capacitor output (5)

If the required compensation power is not reached for one hour, the alarm relay releases for at least one minute.

Supply of real power (6)

If more real power is supplied than consumed (power station service), the alarm relay releases after 100ms latest for at least 1 minute.

Harmonic thresholds (7)

If a value in the selected harmonic threshold table is exceeded, the alarm relay releases after 100ms latest for at least 1 minute.

Overtemperature (8)

The reactive power controller is laid out for the operating temperature range between -10°C and +55°C. The inner temperature of the reactive power controller is about 2°C higher than the temperature within the cabinet.

If the programmable threshold for the controller inner temperature is exceeded, the alarm relay releases after 100ms latest for at least 1 minute.

Setting range for the temperature : 0..99°C



Attention!

For inner temperatures of more than 70°C the alarm will always be raised.

Averaging time for the mean value cos(phi)

Prophi measures real and reactive work within the averaging time and calculates the mean value cos(phi).

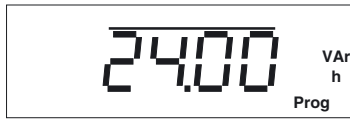

- Setting range:
- 0.25h
 - 0.50h
 - 1.00h
 - 2.00h
 - 12.00h
 - 24.00h (presetting)**

Example: Programming of the averaging time for the mean value cos(phi).

Go to averaging time for the mean value cos(phi) in expanded programming with key 3.
Confirm selection with key 1.

In this example, an averaging time of one hour is indicated and flashes.



With key 2 and 3 the desired averaging time can be selected.
Press key 1 for confirmation and with key 3 you can continue leafing through the expanded programming.

Averaging time of reactive power

The measured reactive power is summarized within the averaging time and the mean value of reactive power is calculated.



- Setting range:
- 0,1 Sec.
 - 0,5 Sec.
 - 1,0 Sec.
 - 5,0 Sec.
 - 10,0 Sec.
 - 30,0 Sec.
 - 60,0 Sec. (Presetting)**

Example: Programming of the averaging time for reactive power.

Go to averaging time for the mean value reactive power in expanded programming with key 3.

Confirm selection with key 1.

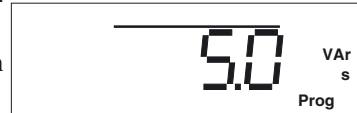

In this example an averaging time of 5 seconds is indicated and flashing.
Now the desired averaging time can be selected with key 2 and key 3.
Press key 1 for confirmation and with key 3 you can continue leafing through the expanded programming.

Ventilator control

With the temperature feeler, inserted in Prophi, and a ventilator, a simple ventilator control can be established.

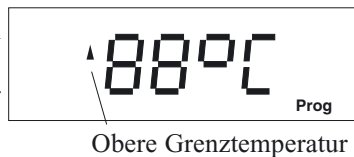

Therefore, an upper temperature limit, a lower temperature limit and a switching output must be fixed.

Please note, that the inner temperature of the Prophi is about 2°C over the outer temperature.

A relay output or the alarm output (option) serves as ventilator output.

If the switching output 0 is assigned to the ventilator control, the ventilator control is not active.

An upper and lower temperature limit can be set. The temperature limits can be set in the range of 0°C and 98°C in 1° steps. While programming, you can only set an upper limit, when it is at least 1°C over the lower limit.

Attention! If an output is programmed for ventilator control, and if it is also programmed for a fix stage or alarm output, the ventilator control has higher priority.

Ventilation control

Using the temperature sensor, which is inserted within Prophi, a simple ventilation control can be built.

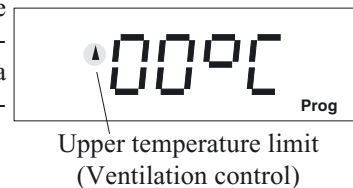

To reach this goal, an upper temperature limit, a lower temperature limit and a switching output must be determined.

While programming of temperature limits, please mind, that the inner temperature of Prophi is about 2°C above the outer temperature.

The temperature limits can be set in the range of 0°C and 98°C in 1°C steps.

While programming, it is only possible to set the upper temperature limit, when it is at least 1°C above the lower limit.

Upper temperature limit

If the upper limit is exceeded, the ventilation is switched on.

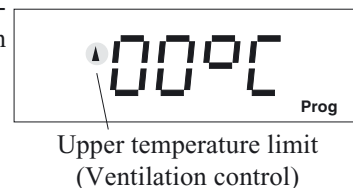

Lower temperature limit

If temperature is below the lower limit, the ventilation is switched off.

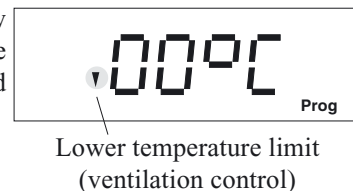

Switching output

One of the relay outputs or the alarm output can be used as switching output of Prophi.

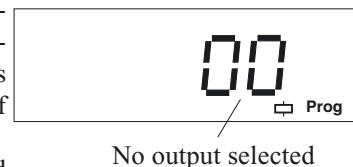

If output 0 is assigned to the ventilation control, the ventilation control is inactivated.



Attention!

If one output has been programmed for ventilation control, and additionally, it is programmed as a fix stage or alarm output, the ventilation control has priority.

Reactive Power Controller **Prophi**[®]

Example: Programming of the lower temperature limit

Go to upper temperature limit in expanded programming using key 3.



Upper temperature limit

Go to lower limit using key 2.

Confirm selection with key 1. The first number is flashing.



Lower temperature limit

Select number with key two and change with key 3.

Confirm selection with key 1. No digit is flashing.

Carry on in expanded programming with key 3.

Example: Assign one output to ventilator control

Go to upper temperature limit in expanded programming using key 3.



No output selected

Move to selection of the output using key 2.

Output number 13 means the alarm output. Confirm selection with key 1. The first digit is flashing.

Select the digit to be changed with key 2 and change with key 3.

Confirm selection with key 1. No digit is flashing.

Carry on in expanded programming with key 3.

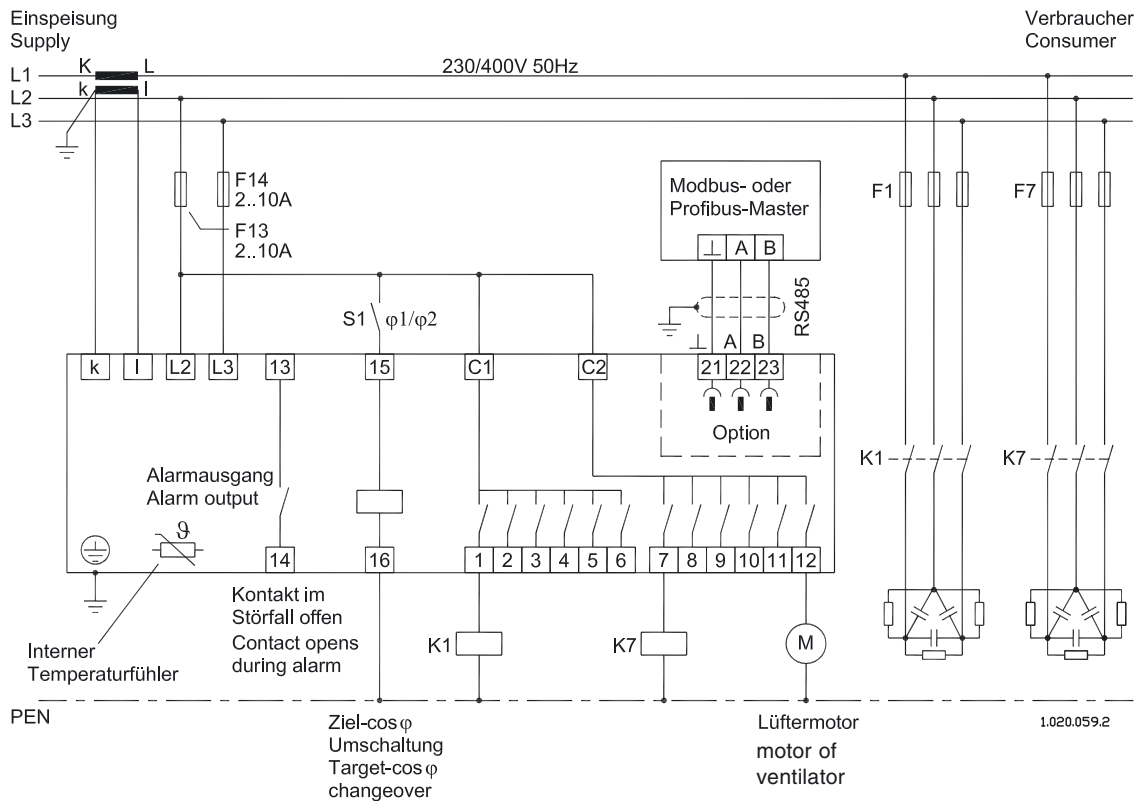

Diagr.: Connection example, reactive power controller with connected ventilator motor

Overtemperature disconnection

In cabinets there might be an exceeding of the inner cabinet temperature, effected by power dissipation of connected capacitor stages or too high outer temperature.



In that case, also the Prophi controller is heated up, and the inner temperature feeler detects this rise of temperature with a little delay. With the overtemperature disconnection, connected stages can be disconnected in order to decrease the inner temperature and to protect the capacitors from damage.

The following values can be set:

- upper temperature limit,
- lower temperature limit and
- pause time.



Attention! The overtemperature disconnection also disconnects programmed fix stages.

Upper temperature limit

If the upper temperature limit is exceeded, connected capacitors are disconnected.

Lower temperature limit

If the lower temperature limit is exceeded, no more stages are connected anymore.

Pause time

If the lower temperature limit is exceeded, one capacitor stage will be disconnected, and the pause time is started. After the pause time is over, the next capacitor stage can be disconnected.

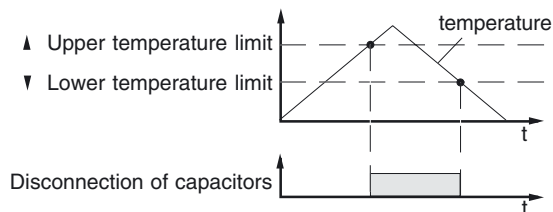

Diagr.: Overtemperature disconnection with hysteresis



Attention! If the upper temperature limit is set below the lower temperature limit while editing, the lower limit is decreased automatically.

Example: Programming of the upper temperature limit

Go to upper temperature limit in expanded programming using key 3.



Confirm selection with key 1. The first digit is flashing.

Select number with key 2 and change with key 3.

Confirm selection with key 1. No digit is flashing.

Carry on in expanded programming with key 3.

Example: Programming of the lower temperature limit

Go to upper temperature limit in expanded programming using key 3.

Then move to lower limit with key 2.

Confirm selection with key 1. The first digit is flashing.

Select number with key 2 and change with key 3.



Confirm selection with key 1. No digit is flashing.

Carry on in expanded programming with key 3.

Example: Programming of the pause time

Go to upper temperature limit in expanded programming using key 3.

Go to pause time with key 2.

Confirm selection with key 1. The first digit is flashing.

Select number with key 2 and change with key 3.

Confirm selection with key 1. No digit is flashing.

Carry on in expanded programming with key 3.



Indication in manual mode

While switching capacitor stages in manual mode, either the actual $\cos(\phi)$ or actual real power can be indicated.



CAr = Indication of reactive power

CoS = Indication of $\cos(\phi)$

Example: Selection of indication in manual mode

Move to selection of the indication in manual mode with key 3.

Confirm with key 1.

The last selected value, CoS or CAr, is flashing.



With key 3 can be changed over to CoS and with key 2 to CAr.

Confirm selection with key 1.

The selected text is no longer flashing.

Carry on expanded programming using key 3.

Password

The settings of Prophi can be protected against unintentional change by a four digit user password. This denies the access to the menus:

- manual mode
- standard programming and
- expanded programming.

Prophi works in automatic mode and only the measured values can be seen.

In **delivery condition, no password** ("0000") is programmed, the user has full access to all menus.

After programming a password, it is always requested before accessing one of the locked menus. The password can be changed within the expanded programming. If ("0000") is entered as a password, the user has full access to all menus.



If a changed password is not known anymore, the device has to be sent back to the manufacturing work.



Enter password

If the programming is protected by a password, you must enter this password to have access to the locked menus.

Press key 1. The first digit is flashing.

Select the number, which should be changed with key 2.

The selected number flashes.

Change number with key 3.

If the password is completed, end input with key 2.

If the password was invalid, the request for a password appears again.



If the password was correct, you are in menu "manual mode" of the standard programming.

Scroll to the required programming menus with key 1.



The programming menus are locked again automatically, when no key was pressed over 60 seconds.

Program password

If no password was programmed so far, please proceed as follows:

Scroll to expanded programming by pressing key 1. The symbol "Prog" is flashing. Confirm selection with key 2.

The menu for programming the fix stages appears.

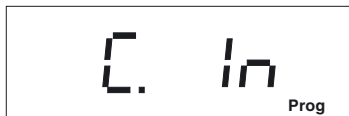

Scroll to menu password by pressing key 3. Confirm selection with key 1.

The first number of the password is flashing.

Select the digit, which shall be changed, with key 2.

The selected number is flashing.

Change number with key 3.

If the password has been completed, confirm password with key 1.

No digit is flashing now.

The new password is active.



Change password

To enter a new password, please change to expanded programming by using the old password, which has to be entered first.

Confirm with key 1.

The first digit of the password is flashing.

Now enter the old password.

Select the number to be changed by key 2, the selected number is flashing.

Change the selected number with key 3.

If the password is completed, confirm with key 2.

If the password was invalid, the request for the password appears again.



If the password was correct, you are in menu "manual mode" of the standard programming.

Now you can overwrite the password as described under "program password".



Entering the password "0000" releases the lock of the programming menus.

Contrast

The preferred view of the indication is "from below", which means, that the display can be read best in this view.

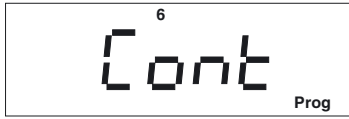

The contrast between the characters and the background is the highest. Little changes of the view can be evened out by the contrast setting. The contrast of the indication can be changed by the user.

Setting range 1 - 12

To get an optimal contrast for the whole temperature range, the contrast of the indication is self adjusting for changes of the ambient temperature. This correction is not indicated in the contrast setting.

Example: Programming contrast

Move to contrast in the expanded programming using key 3. Confirm with key 1. The text "Cont" is flashing.

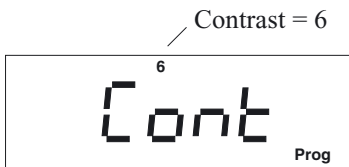

Go to the next higher digit using key 2.

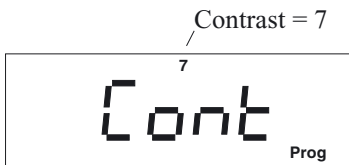

Go to the next smaller digit using key 3.

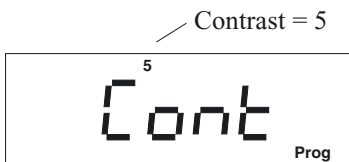

Pressing key 1 you leave the programming mode and with key 3 you can continue leaving through the expanded programming.

Reset programming

With the function "Reset programming" the programming carried out are deleted and overwritten by the

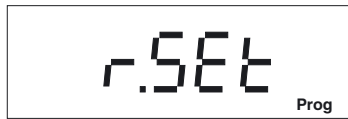

manufacturer's programming. The programming is now in the same condition as delivered.

To avoid unintentional deleting, the four digit reset password must be entered additionally. The reset password can be requested in the manufacturing work.

Example: Programming reset

Go to reset in the expanded programming using key 3.

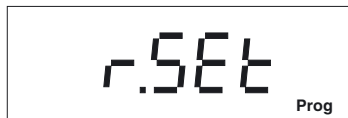

Confirm with key 1.

The password indication appears.

Enter password.



Select the digit to be changed using key 2.

The selected digit is flashing

Change the selected digit by pressing key 3.

If all ciphers are programmed correctly, all ciphers disappear in the indication, and the manufacturer's programming is loaded. Prophi keeps working in automatic mode.

Connection configuration

Prophi can be delivered in two connection varieties for the measurement and supply voltage.



In the version **measurement L-L**, the measurement and supply voltage must be taken from two outer conductors. In version **measurement L-N**, the measurement and supply voltage must be taken between outer conductor L and neutral N.

Correction angle

The controller Prophi indicates the power factor, real and reactive power correctly, if current and voltage were connected according to the type plate and connection diagram. The phase shift between voltage and current must not be corrected, and the correction angle is 0°.

The correction angle can be selected in the range of 0° - 359° in one degree steps.

If the user cannot connect Prophi according to the connection diagram, this can be corrected according to the correction values of table 1 or 2.

Devices for version **L-N** can be corrected with the correction angles of table 1.

Devices for version **L-L** can be corrected with the correction angles of table 2.

If the connection fault is not known, the correction angle can be determined automatically by using the **"learn"** function.

Example : Programming of the correction angle

The current transformer is installed in L2. "k-l" is not exchanged. The voltage measurement is done according to connection diagram between L2-L3.

Table: Correction angle

Current in	Voltage between					
	L1-L2	L2-L1	L2-L3	L3-L2	L3-L1	L1-L3
L1 k-l	240°	60°	0°	180°	120°	300°
l-k	60°	240°	180°	0°	300°	120°
L2 k-l	120°	300°	240°	60°	0°	180°
l-k	300°	120°	60°	240°	180°	0°
L3 k-l	0°	180°	120°	300°	240°	60°
l-k	180°	0°	300°	120°	60°	240°

In that case you can read the angle of 240° in the table "correction angle".

Confirm selection with key 1. One digit is flashing.



Change the selected digit using key 2. The selected digit is flashing. Change the selected digit using key 3.

Leave programming mode with key 1. No digit is flashing anymore.

With key 3 you continue moving through the expanded programming.

Table 1: Correction angle, **measurement L-N**

Current in	Voltage between					
	L3-N	N-L3	L1-N	N-L1	L2-N	N-L2
L1 k-l	240°	60°	0°	180°	120°	300°
l-k	60°	240°	180°	0°	300°	120°
L2 k-l	120°	300°	240°	60°	0°	180°
l-k	300°	120°	60°	240°	180°	0°
L3 k-l	0°	180°	120°	300°	240°	60°
l-k	180°	0°	300°	120°	60°	240°

Table 2: Correction angle, **measurement L-L**

Current in	Voltage between					
	L1-L2	L2-L1	L2-L3	L3-L2	L3-L1	L1-L3
L1 k-l	240°	60°	0°	180°	120°	300°
l-k	60°	240°	180°	0°	300°	120°
L2 k-l	120°	300°	240°	60°	0°	180°
l-k	300°	120°	60°	240°	180°	0°
L3 k-l	0°	180°	120°	300°	240°	60°
l-k	180°	0°	300°	120°	60°	240°

Software release

The software for Prophi is improved and ex-panded continuously. The software release of the device is given by a number, the software release. The software release cannot be changed by the user.



Serial number

Each device has its own unchangeable 8 digit serial number. The serial number is laid down in two pictures.

If you are in the indication of the software release, please call the first and second part of the serial number by pressing key 2.

Serial number, part 1

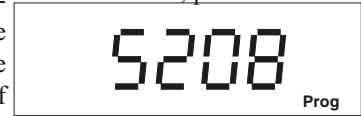

Serial number, part 2



Serial interface (Option)

Device address

If several devices are connected via RS485, a master (PC/PLC) can tell the difference between them by their de-



vice addresses. Within one network, each **Prophi** must have its own device address.

If Profibus protocol has been chosen, the address can be given between 0 and 126. If Modbus protocol has been chosen, the address can be given between 0 and 255.

The device address can be requested and changed in menu "advanced programming".

Example: Change device address.

With key 3 you can move to device address in expanded programming.



Confirm selection with key 1.

In this example the device address is indicated as 1.

Select the number to be changed by using key 2.

The selected digit is flashing.

Change digit with key 3.

Confirming key 1 for about 2 seconds, the changes are saved and **Prophi** keeps working in automatic mode.

Transmission protocol

For the connection of Prophi to an existing field bus system are two transmission protocols available:



0 - Modbus RTU (Slave) and

1 - Profibus DP V0 (Slave) .

With Modbus protocol you have access to the data from table 1 and with Profibus protocol you have access to the data of table 2.

Example: Select transmission protocol.

Please move to device address in expanded programming using key 3. Now press key 2 for transmission protocol.



Confirm selection with key 1.

In this example the transmission protocol is protocol 1=Profibus DP. Digit 1 is flashing.

Please change over between protocol 1 and 2 by pressing key 3.

Confirming key 1 for about 2 seconds, the changes are saved and **Prophi** keeps working in automatic mode.



Attention!

If a switching frequency of 50Hz is programmed for the transistor outputs, the serial interface does not work!

Baud rate

The setting of the baud rate is valid for Modbus RTU only.



For Profibus DP V0 protocol the set baud rate is not used, but will be determined by the master (e.g. PLC) and transmitted to **Prophi**.

Example: Select baud rate.

Please move to device address in expanded programming using key 3.



Now go to baud rate using key 2.

Confirm with key 1.

In this example, the baudrate 4= 115.2kbps is indicated, the number is flashing.

Select baud rate with key 3 (0, 1, 2, 3 or 4).

Confirming key 1 for about 2 seconds, the changes are saved and **Prophi** keeps working in automatic mode.

Number	Baud rate for Modbus RTU
0	9.6 kbps
1	19.2 kbps
2	38.4 kbps
3	57.6 kbps
4	115.2 kbps

Modbus RTU

Transmission mode

RTU-Mode with CRC-Check

Transmission parameters

Baud rate : 9.6, 19.2, 38.4, 57.6, 115.2kbps

Data bits : 8

Parity : none

Stop bits : 2

Realised functions

Read Holding Register, Function 03

Preset Single Register, Function 06

Preset Multiple Register, Function 16

Data formats

char : 1 Byte (0 .. 255)

word : 2 Byte (-32768 .. +32767)

long : 4 Byte (-2 147 483 648 .. +2 147 483 647)

The sequence of bytes is highbyte before lowbyte.

Profibus DP V0

The **Prophi** is a slave device and corresponds to the fieldbus directive PROFIBUS DP V0, DIN E 19245 part 3. The PROFIBUS user organization has listed **Prophi** with the following entries:

Device description : Prophi

Ident-Number : 04B9 HEX

GSD : PROF04B9.GSD

The GSD file is specific for the device. Here the transmission parameters and the kind of measured data are determined. The GSD file for **Prophi** with option "Interface" belongs to the contents of delivery.

While creating the program for the PLC (master), the GSD file is implemented into PLC program.

Table Modbus

Description	Address	r/w	Format	Unit	Comment
Current	1000	r	word	mA	
Voltage L-L	1002	r	word	V	Urated +10% -15%
Reactive power	1004	r	word	Var	+ = cap, - = ind
Cos(phi)	1006	r	word		+ = cap, - = ind
Outputs	1008	r	word		Bit 0 K1 (1=On, 0=Off) Bit 1 K2 Bit 2 K3 Bit 11 K12 Bit 12 Alarm output
Alarm calls	1010	r	word		Bit 0 Low voltage Bit 1 Overvoltage Bit 2 Current too low Bit 3 Current too high Bit 4 Insufficient capacitor power Bit 5 Supply of real power Bit 6 Harmonic limits exceeded Bit 7 Overtemperature
Switchings, K1	1012	r	unsigned long		Number of switchings per capacitor stage (0 .. 4 200 000 000)
Switchings, K2	1016	r	unsigned long		
...					
Switchings, K12	1056	r	unsigned long		
Connect. time, K1	1060	r	unsigned long		Total connection time per capacitor stage in seconds. (0 .. 4 200 000 000)
Connect. time, K2	1064	r	unsigned long		
...					
Connect. time, K12	1104	r	unsigned long		
Outputs, remote	2000	w	word		Bit 0 K1 (1=On, 0=Off) Bit 1 K2 Bit 2 K3 Bit 11 K12 Bit 12 free Bit 13 Tariff Bit 14 Remote Tarif Bit 15 Remote Outputs
1. Harmonic, I	1108	r	word	mA	16 Bit, 0..5000mA
3. Harmonic, I	1110	r	word	mA	16 Bit, 0..5000mA
...					
19. Harmonic, I	1126	r	word	mA	16 Bit, 0..5000mA
1. Harmonic, U	1128	r	word	0,1V	16 Bit, Unit 0.1Volt
3. Harmonic, U	1130	r	word	0,1V	16 Bit, Unit 0.1Volt
...					
19. Harmonic, U	1146	r	word	0,1V	16 Bit, Unit 0.1Volt
Current transformer ratio	1148	r	word	16Bit	
Voltage transformer Primary	1150	r	word	16Bit	



Attention!

The current and voltage transformer ratios have not been respected at the statements for the measured values.

Table Profibus

Description	PEW	PAW	Format	unit	Comment
Current	0		word	mA	
Voltage L-L	2		word	V	Urated +10% -15%
Reactive power	4		word	Var	+ = cap, - = ind
Cos(phi)	6		word		+ = cap, - = ind
Outputs	8		word		Bit 0 K1 (1=On, 0=Off) Bit 1 K2 Bit 2 K3 Bit 11 K12 Bit 12 Alarm output
Alarm outputs	10		word		Bit 0 Low voltage Bit 1 Over voltage Bit 2 Current too low Bit 3 Current too high Bit 4 Insufficient capacitor power Bit 5 Supply of real power Bit 6 Harmonic limits exceeded Bit 7 Over temperature
Outputs, remote		0	word		Bit 0 K1 (1=On, 0=Off) Bit 1 K2 Bit 2 K3 Bit 11 K12 Bit 12 free Bit 13 Tariff Bit 14 Remote Tarif Bit 15 Remote Outputs



Attention!

The Current and voltage transformer ratios are not mentioned for measured values.

Display overview

Measured value indications

Diagr.: Measured value indications, part 1 of 2

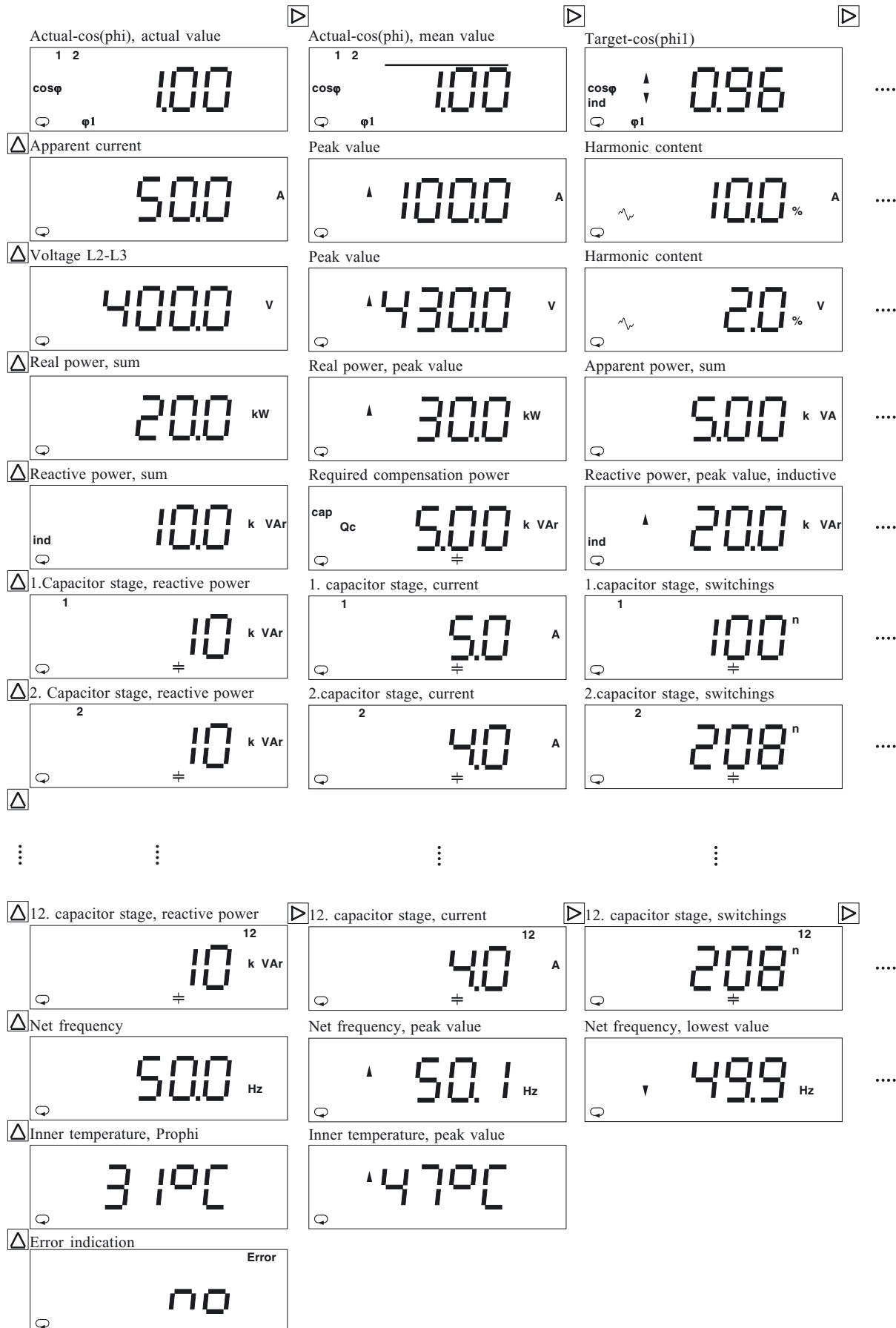

Diagr.: Measured value indications, part 2 of 2

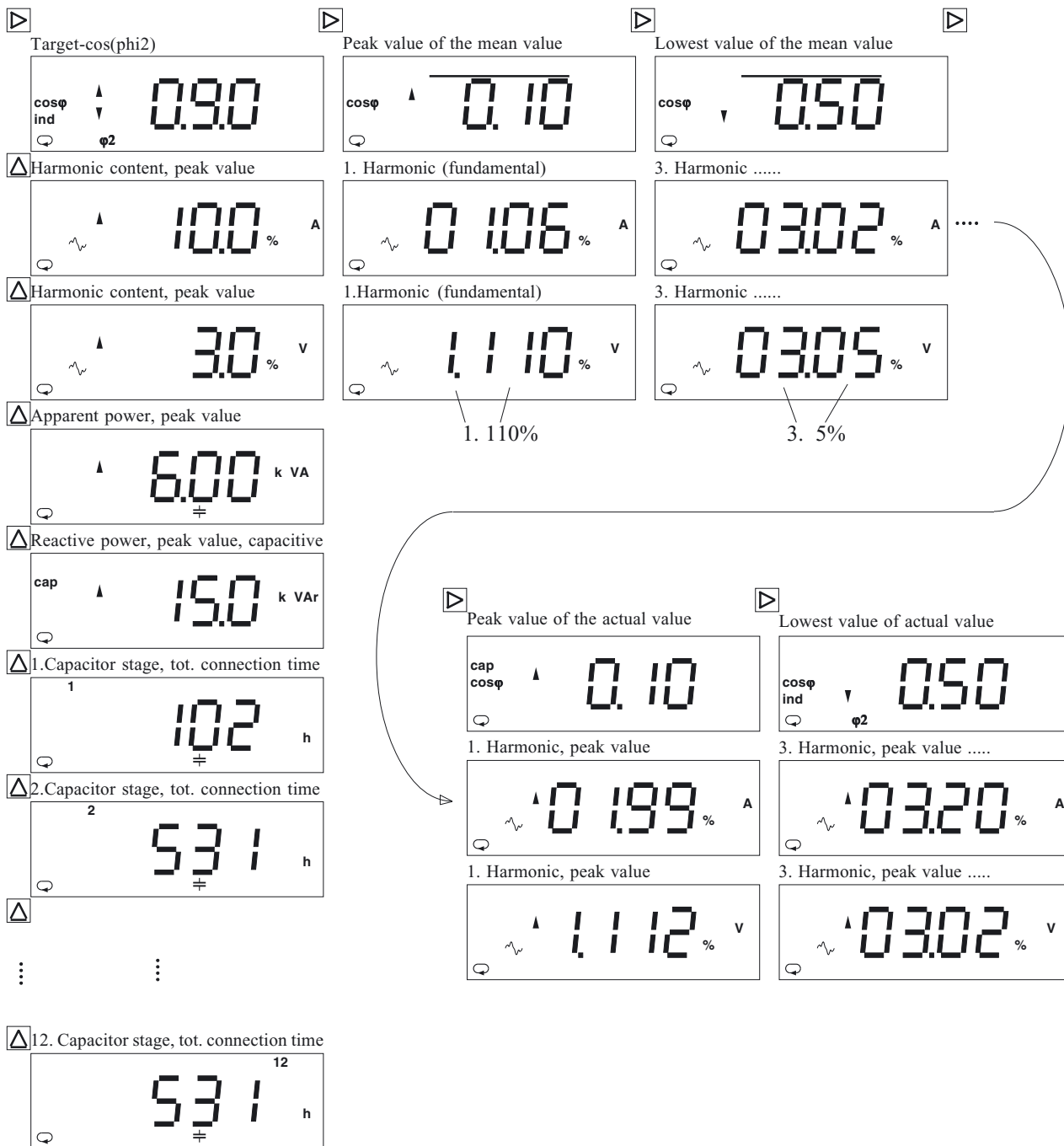

Display in standard programming

Diagr.: Standard programming

Target-cos(phi1)

cosφ
ind
φ1
0.95

⇒ Target-cos(phi2)

cosφ
ind
φ2
0.90

⇒ Current transformer ratio

1000 k
IT

⇒ Learning of connection configuration

oFF
learn

⇒ Stage power of the first stage

10.00 k VAr
=

⇒ Stage ratio

2.488
1:1...

⇒ Number of switching outputs

12
□

⇒ Delete peak values

↓ dEL

⇒ Expanded programming

Pro.
Prog

Display in expanded programming

Diagr.: Expanded programming, Part 1 of 2

Fix stages

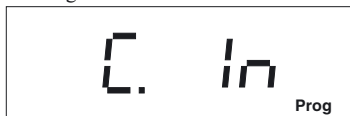

Discharge time

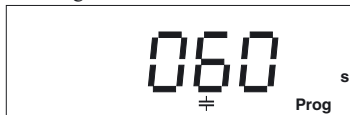

Disconnection pause for relay stages

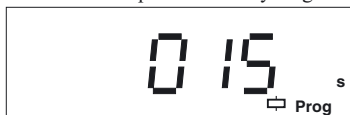

Power station service

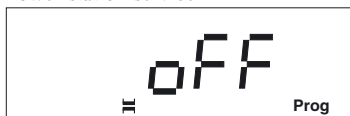

Stage power



Stage power

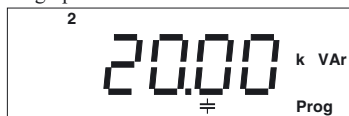

Stage power



Choke degree

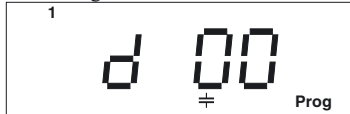

Choke degree, 2. capacitor stage

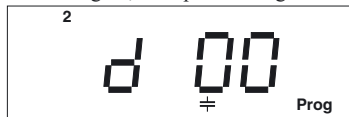

Choke degree, 3. capacitor stage

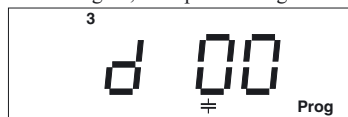

Voltage transformer ratio



Harmonic table

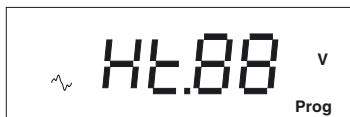

Alarm message, overtemperature



Switching frequency

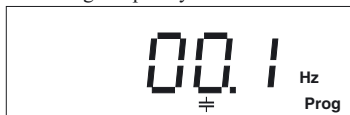

Alarm message, max. measured current



Alarm message, harmonic table



Alarm message, min. measured current

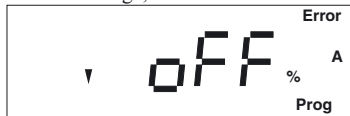

Alarm message, supply of real power

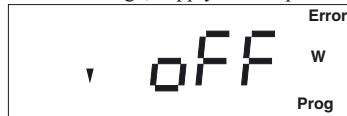

Alarm message, lower voltage



Alarm message, over voltage



Alarm message, compensation power

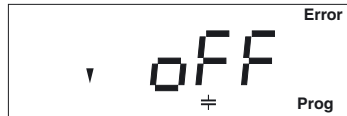

Reactive Power Controller **Prophi**[®]

Diagr.: Expanded programming, part 2 of 2

Averaging time for mean value cos(phi)

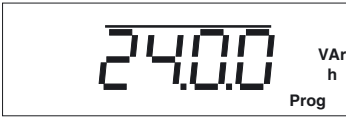

Averaging time for reactive power



Ventilator control, upper temperature limit



Fan control, lower temperature limit



Ventilator control, output



Overtemperature disconnection, pause time



Overtemperature disconnection, upper limit

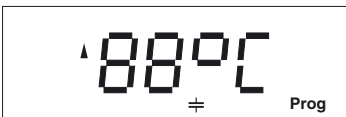

Overtemperature disconnection, lower limit

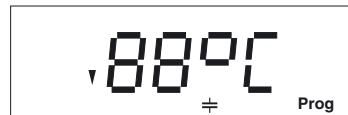

Display in manual mode



Password



Contrast

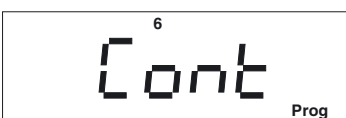

Reset programming

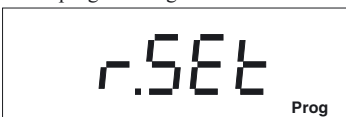

Connection configuration



Software Release

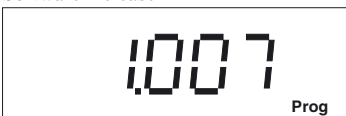

Serial number, part 1

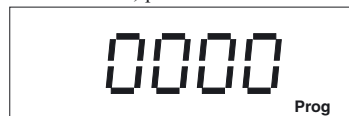

Serial number, part 2



Address



Protocol

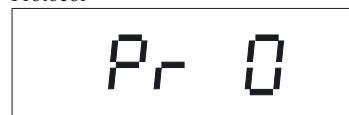

Baud rate



Configuration data

	Description	Setting range	Manufacturer's presetting
Standard programming	Target-cos(phi1)	0.80cap. .. 1.00 .. 0.80ind.	0.96ind
	Target-cos(phi2)	0.80cap. .. 1.00 .. 0.80ind.	0.90ind
	CT ratio	1 .. 9999	10
	Learning of configuration	oN, oFF	oFF
	Stage power of 1. stage	0var .. 9999kvar	10kvar
	Stage ratio	0 .. 9	1:1:1:1
	Switching outputs	1 .. 12	all stages
Expanded programming	Fix stages	0 .. 3	0 = no fix stages
	Discharge time	0 .. 1200 seconds	60 Sec.
	Disconnection pause for relay stages	0 .. 1200 seconds	40 Sec.
	Switching frequency for semic. stages	0.1, 0.2, 0.5, 1.0, 10.0, 50.0Hz ¹⁾	1.0 Hz
	Power station service	on, oFF	oFF
	Stage power, 1. - 12. capacitor stages	0var .. 9999kvar	10kvar
	Choke degree	0 .. 15%	0 %
	VT ratio		
	Number 1 (Primary)	1 .. 9.999k	1
	Number 2 (Secondary)	1, 10, 100, 110, 200, 230, 400	1
	Harmonic table number	0 .. 10	0
	Alarm calls		
	Low voltage	on/1, oFF	oFF
	Overvoltage	on/2, oFF	oFF
	Current too low	on/3, oFF	oFF
	Current too high	on/4, oFF	oFF
	Insufficient capacitor power	on/5, oFF	oFF
	Supply of real work	on/6, oFF	oFF
	Harmonic limits exceeded	on/7, oFF	oFF
	Overtemperature	on/8, oFF	oFF ²⁾
	Averaging time of reactive power	0.1, 0.5, 1.0, 5.0, 10.0, 30.0, 60.0Sek.	60.00 Sec.
	Averaging time for mean value cos(phi)	0.25, 0.50, 1.00, 2.00, 12.00, 24.00h	24.00 h
	Ventilator control		
	Upper temperature limit	0 .. 99°C	0°C
	Lower temperature limit	0 .. 98°C	0°C
	Output number	0 .. 13 (13 = alarm output)	0 = no ventilator control
	Overtemperature disconnection		
	Upper limit	0 .. 99°C	55°C
	Lower limit	0 .. 98°C	50°C
	Pause time	0 .. 1200 seconds	600 seconds
	Indication in manual mode	CoS = cos(phi), CAr = react. power	CAr = react. power
	Password	0 .. 9999	0000 = no password
	Contrast	1 .. 12	6
Reset programming			
Connection configuration	0° .. 359°	000°	
Software Release	x.xxx	actual version	
Serial number part 1	xxxx	depending on device	
Serial number part 2	xxxx	depending on device	
Serial interface			
Device address	0 .. 126	001	
Protocol	0 .. 1	0	
Baud rate			
Modbus RTU	0=9.6, 1=19.2, 2=38.4, 3=57.6, 4=115.2	0 (= 9.6kbps)	
Profibus DP V0	Automatical adaption up to 1.5Mbps at maximum		

¹⁾ For inner temperatures of over 70°C an alarm is always raised.

²⁾ If a switching frequency of 50Hz is programmed for the transistor outputs, the serial interface does not work!

Technical data

Weight	: 1kg
Combustion value	: ca. 700J (190Wh)
Ambient conditions	
Overvoltage class	: III
Pollution degree	: 2
Operating temperature	: -10°C .. +55°C
Storing temperature	: -20°C .. +60°C
Sensibility to disturb. (industrial areas)	: EN55082-2:1995
Spurious radiation (residential areas)	: EN55011 10.1997
Safety guidelines	: EN61010-1 03.1994 + A2 05.1996 IEC1010-1 1990 + A1 1992
Mounting position	: any
Operating height	: 0 .. 2000m over NN
Humidity class	: 15% to 95% without dew
Protection class	: I = Device with protective wire
Protection class	
Front	: IP65 according to IEC529
Back	: IP20 according to IEC529

Inputs and outputs

Tariff changeover	
Current consumption	: about 2,5mA .. 10mA
Switching outputs	
Testvoltage against ground	: 2200V AC
Relay outputs	
Switching voltage	: max. 250VAC
Switching power	: max. 1000W
Max. switching frequency	: 0,25Hz
Mechanical life expectancy	: >30x10 ⁶ switchings
Electrical life expectancy	: >7x10 ⁶ switchings (Load = 200VA, cosphi=0,4)
transistor outputs	
Switching voltage	: 15 .. 30VDC
Switching current	: max. 50mA
Max. switching frequency	: 10Hz

Measurement

Measurement and supply voltage U:	see type plate
Range for U	: +10% , -15%
Prefuse	: 2A .. 10 A
Power consumption	: max. 7VA
Rated pulse voltage	: 4kV
Tested voltage against ground	: 2200V AC
Frequency of fundamental	: 45Hz .. 65Hz
Current measurement	
Signal frequency	: 45Hz .. 1200Hz
Power consumption	: about 0,2 VA
Rated current at..5A (/1A)	: 5A (1A)
Minimum working current	: 10mA
Maximum current	: 5,3A (sinus shape)
Overload	: 180A for 2 Sec.
Measuring rate	: 30(50) Measurement/Sec.
Actualization of indication	: 1 / second
Zero voltage release	: < 15ms

Measurement accuracy

Voltage	: +- 0,5% omr
Current	: +- 0,5% omr
cos(phi)	: +- 1,0% omv ¹⁾²⁾
Power	: +- 1,0% omr
Frequency	: +- 0,5% omv ²⁾

Those specifications presuppose a yearly calibration and a preheating of 10 minutes.

omr = of measuring range
omv = of measured value

1) Valid for current inputs >0.2A and in cos(phi) range 0,85 up to 1,00.

2) In the range of -10..18°C and 28..55°C an additional inaccuracy of +-0,2% of measured value per K must be respected.

3) Devices with option "RS485 interface" are only suitable for an ambient temperature of -10°C .. +50°C.

Back Side

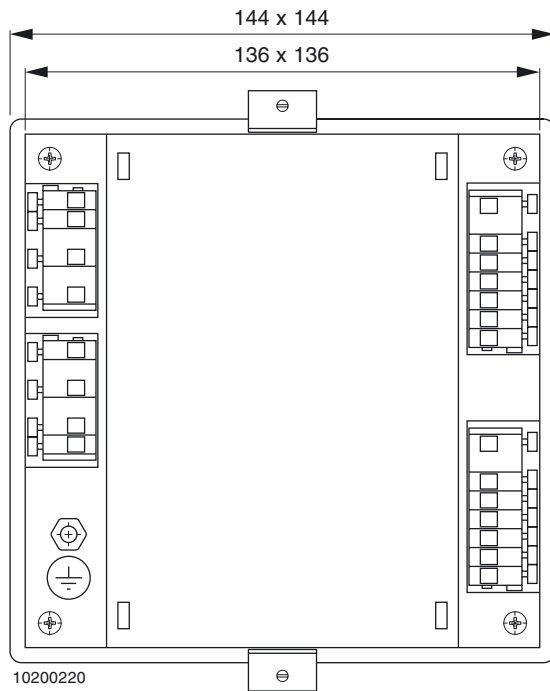

Side view

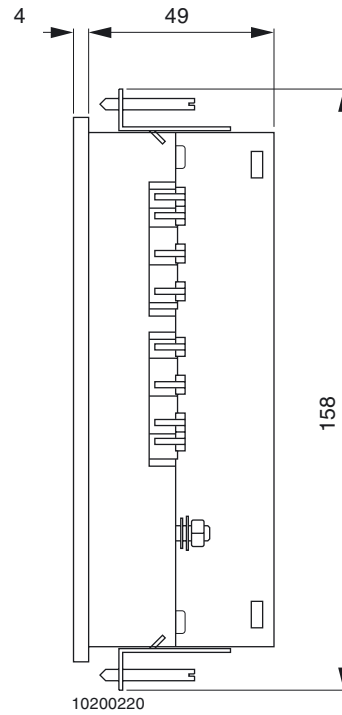

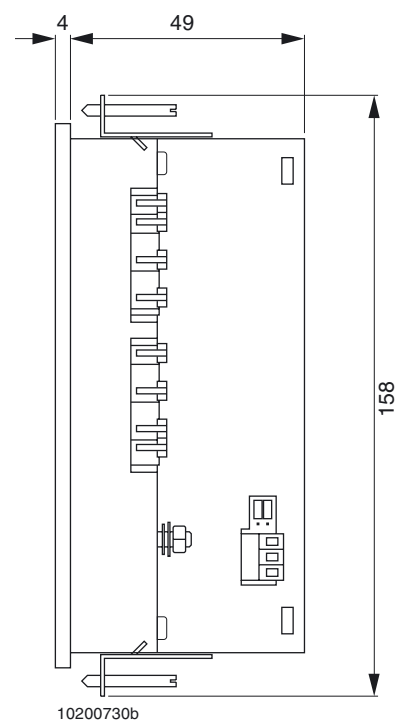
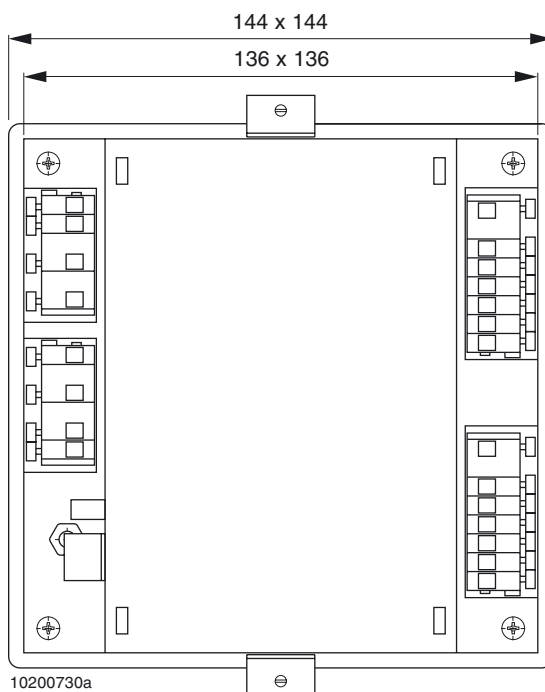

Dimension sketch for devices with option "RS485 interface"







Short manual

Learning of configuration

<p>Target-cos(phi1)</p> 	<ul style="list-style-type: none"> ⇨ 2 Sec. Select automatic mode ⇨ 2 x Select target-cos(phi1) ▶ Select digit △ Change digit ⇨ 2 Sec. Save and go to automatic mode
<p>Current transformer ratio</p> 	<ul style="list-style-type: none"> ⇨ 2 Sec. Select automatic mode ⇨ 4 x Select current transformer ratio ▶ Select digit △ Change digit ⇨ 2 Sec. Save and go to automatic mode
<p>Learning</p> 	<ul style="list-style-type: none"> ⇨ 2 Sec. Select automatic mode ⇨ 5 x Select learn △ Select no. 3 ⇨ Start learning procedure

or

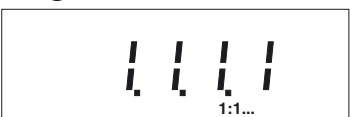
Programming of configuration

<p>Target-cos(phi1)</p> 	<ul style="list-style-type: none"> ⇨ 2 Sec. Select automatic mode ⇨ 2 x Select target-cos(phi1) ▶ Select digit △ Change digit ⇨ 2 Sec. Save and go to automatic mode
<p>Current transformer ratio</p> 	<ul style="list-style-type: none"> ⇨ 2 Sec. Select automatic mode ⇨ 4 x Select current transformer ratio ▶ Select digit △ Change digit ⇨ 2 Sec. Save and go to automatic mode
<p>Stage power</p> 	<ul style="list-style-type: none"> ⇨ 2 Sec. Select automatic mode ⇨ 6 x Select stage ratio ▶ Select digit △ Change digit ⇨ 2 Sec. Save and go to automatic mode
<p>Stage ratio</p> 	<ul style="list-style-type: none"> ⇨ 2 Sec. Select automatic mode ⇨ 7 x Select stage ratio ▶ Select digit △ Change digit ⇨ 2 Sec. Save and go to automatic mode
<p>Number of stages</p> 	<ul style="list-style-type: none"> ⇨ 2 Sec. Select automatic mode ⇨ 8 x Select number of stages ▶ Select digit △ Change digit ⇨ 2 Sec. Save and go to automatic mode