

Two-Wheel Tractor 3900

Petrol Engine EH 25 D
Diesel Engine L100AE

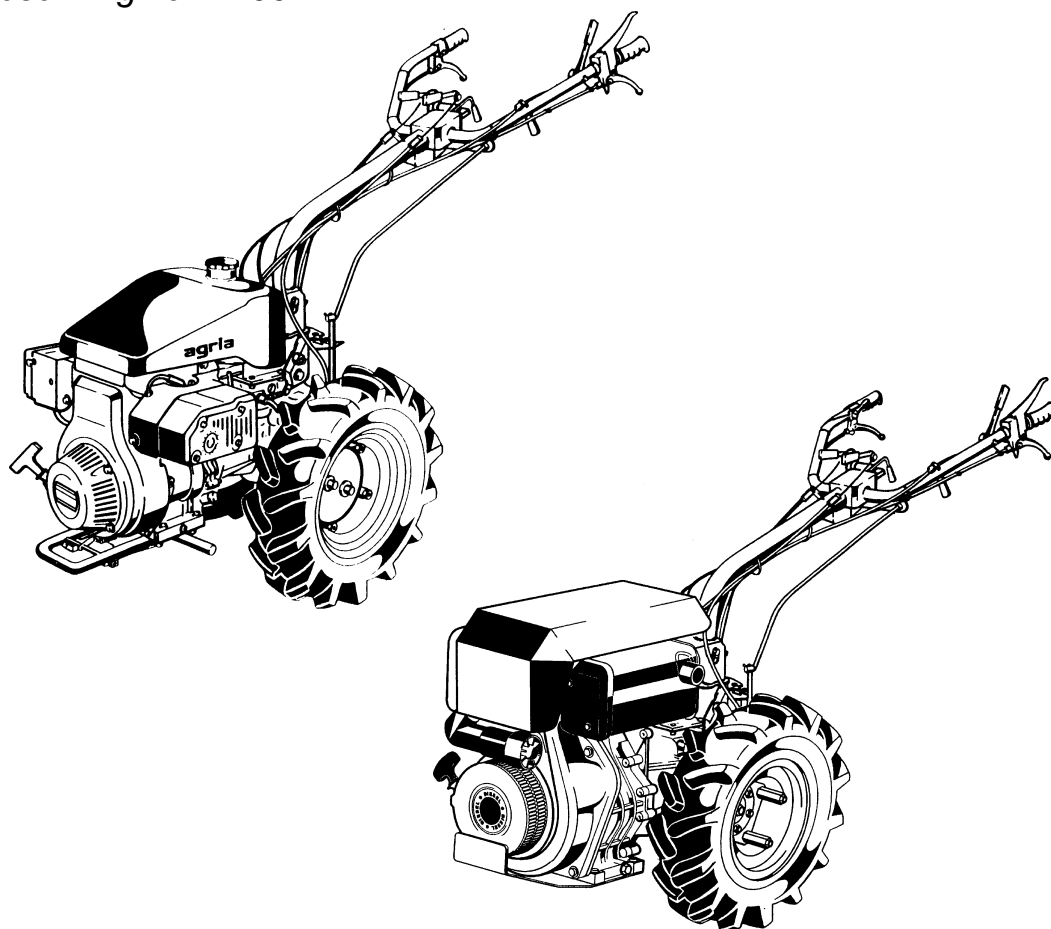

3658; 4431



Before commissioning the machine, read operating instructions and observe warnings and safety instructions.



Please complete:

Machine Type No.:.....
ID/Machine No.:
.....
Engine Type:.....
Engine No.:.....
Date of Purchase:.....

For name plate, refer to p3/fig. A/15, p7/fig. C/15.

For engine type and number, refer to p66/fig. D/17 and p70/fig. E/5.

Please state these data when ordering spare parts to avoid wrong deliveries.

Only use original agria spare parts!

Specifications, figures and dimensions stated in these instructions are not binding. No claims can be derived from them. We reserve the right for improvements without changing these instructions.

This delivery comprises:

- Operating instructions
- Two-wheel tractor
 - Basic machine
 - Steering handle
- Tool kit

→ **agria - Service** ← = contact your agria-workshop

Symbols



Warning – Danger



Important information



Fuel



Choke



Battery charge indicator



Clutch



Forward



Reverse



Fast



Slow



Differential Lock



wheel drive



PTO



Brake



Parking Brake



Closed (locked)



Open (unlocked)

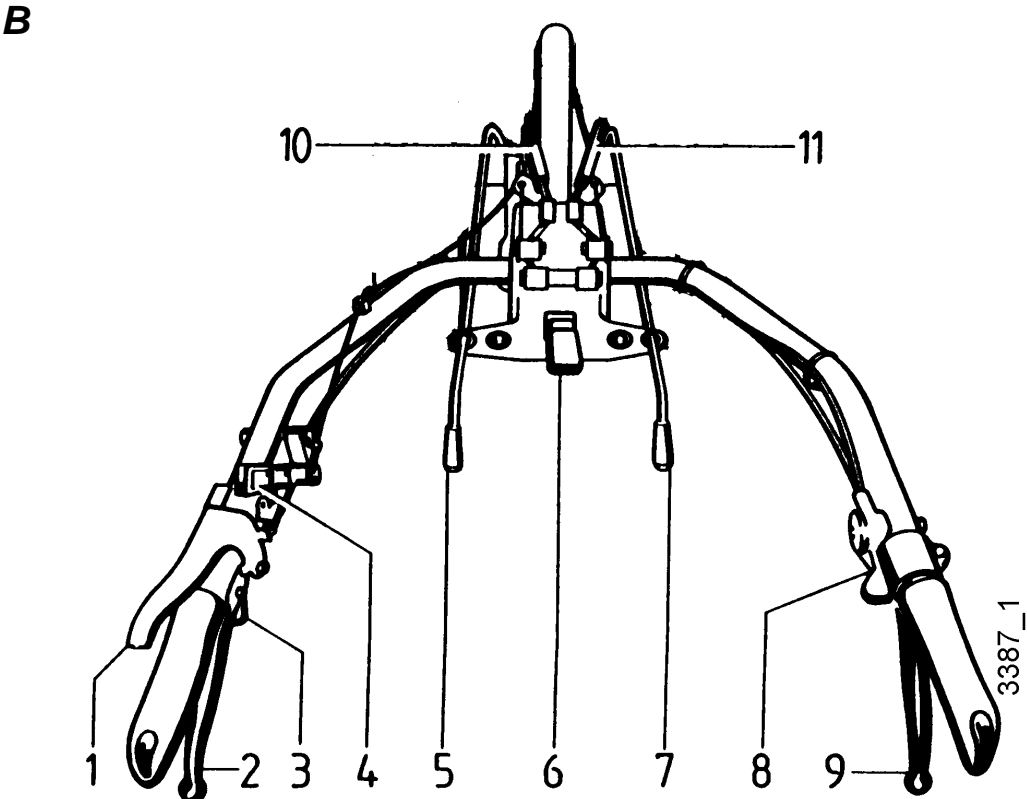
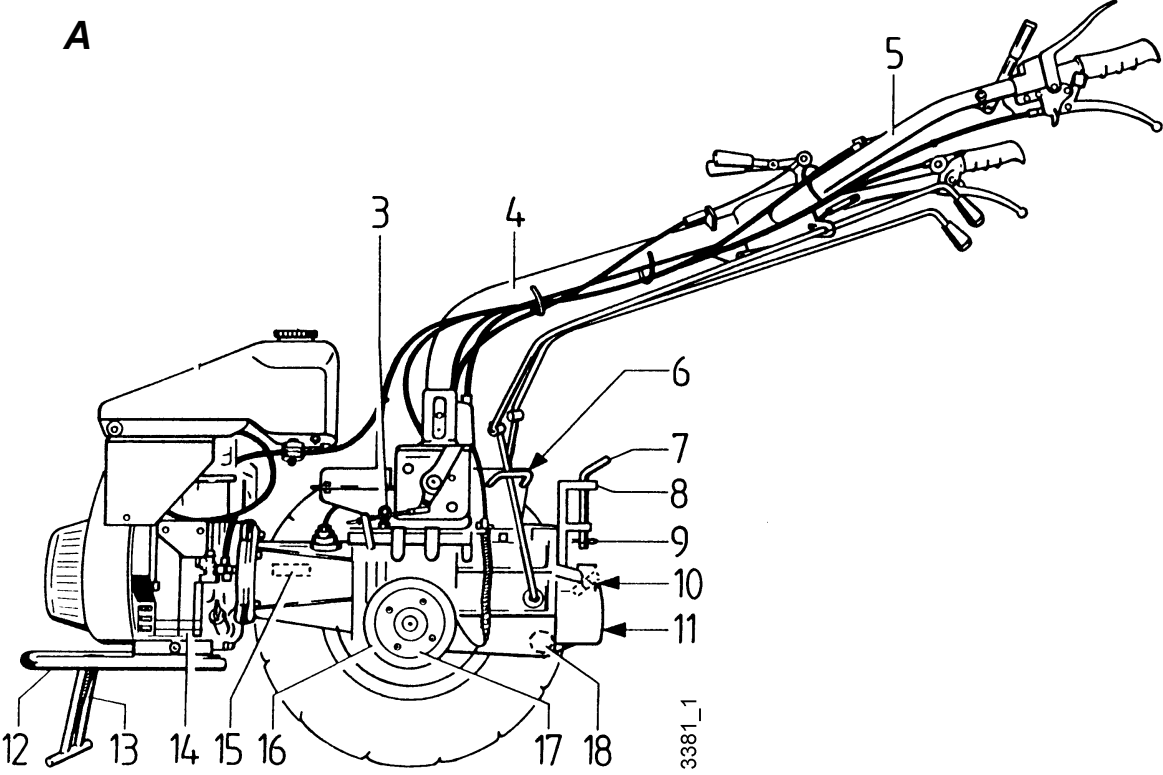

Figure A:

- 3 Oil filling opening of drive gear
- 4 Steering bar
- 5 Handlebar
- 6 Reverse lock
- 7 Lock pin
- 8 Clevis
- 9 W-clip
- 10 Locking lever for attachment coupling
(on the right, seen in travel direction)
- 11 Attachment coupling point with integrated PTO
- 12 Weight support and engine hoob guard
- 13 Support leg
- 14 Engine
- 15 Name plate (on the right, seen in travel direction)
- 16 Single wheel brake
- 17 Wheel flange
- 18 Transmission oil drain plug (on the right, seen in travel direction)

Figure B:

- 1 Safety lever
- 2 Hand lever for engine clutch
- 3 Pawl for engine clutch hand lever
- 4 Hand lever for differential lock
- 5 PTO shifter
(with steering handle swivelled [front attachment] = Gear shifter)
- 6 Locking lever for steering handle side adjustment
- 7 Gear shifter
(with steering handle swivelled [front attachment] = PTO shifter)
- 8 Speed adjustment lever
- 9 Handle lever
- 10 Hand lever for steering brake, left
- 11 Hand lever for steering brake, right

Amount of Delivery 2

Recommendations

Lubricants 6

Maintenance and Repair 6

Fuel 9

Assembly Instructions 10

Designation of Parts 3, 7, 66, 70

1. Safety Instructions 12 - 18

2. Specifications

Dimensions 19

Track Width 19

Machine 20

Vibration Acceleration Value 20

Petrol Engine 21

Diesel Engine 22

Noise Levels 21, 22

Operation on Slopes 21, 22

3. Devices and Operating Elements

Engine 23

Safety Circuit 24

Clutch 25

Gearbox 26

Differential Gear 26

Single-Wheel Brake 27

Central Brake 27

PTO 28

Reversing Lock 28

Steering Handle 29

Drive-Wheels 31

Front Weight 32

Support leg 32

Coupling and Decoupling Attachments 33

Engine Cover 36

4. Commissioning and Operation

Commissioning the Petrol Machine 37

Starting the Petrol Engine 38

Switching off the Petrol Engine 39

Commissioning the Diesel Machine 40

Starting the Diesel Engine 41

Switching off the Diesel Engine 42

Operations 43

1

2

5. Maintenance

Petrol Engine 45–49

- Air Filter 46

- Spark Plug 47

Diesel Engine 50 - 53

- Engine Oil Filter 50

- Air Filter 51

Machine 54

Adjustments on Hand Levers 56

General 57

Storage 58

3

4

6. Troubleshooting 60 - 62

Electrical Wiring Diagram 63

Varnishes, Wear Parts 64

Inspection and Maintenance Chart 68

Conformity Declaration 71



Note fold-out pages!

Fig. A + B, Petrol Engine Vers. . 3

Fig. B + C, Diesel Engine Vers. 7

Fig. D, Diesel Engine 66

Fig. E, Petrol Engine 70

5

6

Lubricants and Anti-Corrosive Agents:

Use the lubricants specified for engine and gearbox (see “Specifications”).

We recommend using **Bio-lubricating oil** or **Bio-lubricating grease** for “open” lubrication points or nipples (as specified in the operating instructions).

We recommend using **Bio-slushing oil** to preserve machines and attachments (do not apply on painted covers). you can brush or spray the oil.

Anti-corrosive agents are environmentally friendly and degrade fast.

Using ecologically safe Bio-lubricants and Bio-anti-corrosives, you contribute to environmental protection and to the wellbeing of humans, animals and plants.

Maintenance and Repair:

The trained mechanics of your agria workshop expertly carry out any maintenance and repair work.

you should only carry out major maintenance work and repairs on your own, if you have the proper tools and knowledge of machines and internal combustion engines.

Do not hammer against the flywheel with a hard object or metal tools as it might crack and shatter in operation, causing injuries and damage. Only use suitable tools to pull off the flywheel.

C

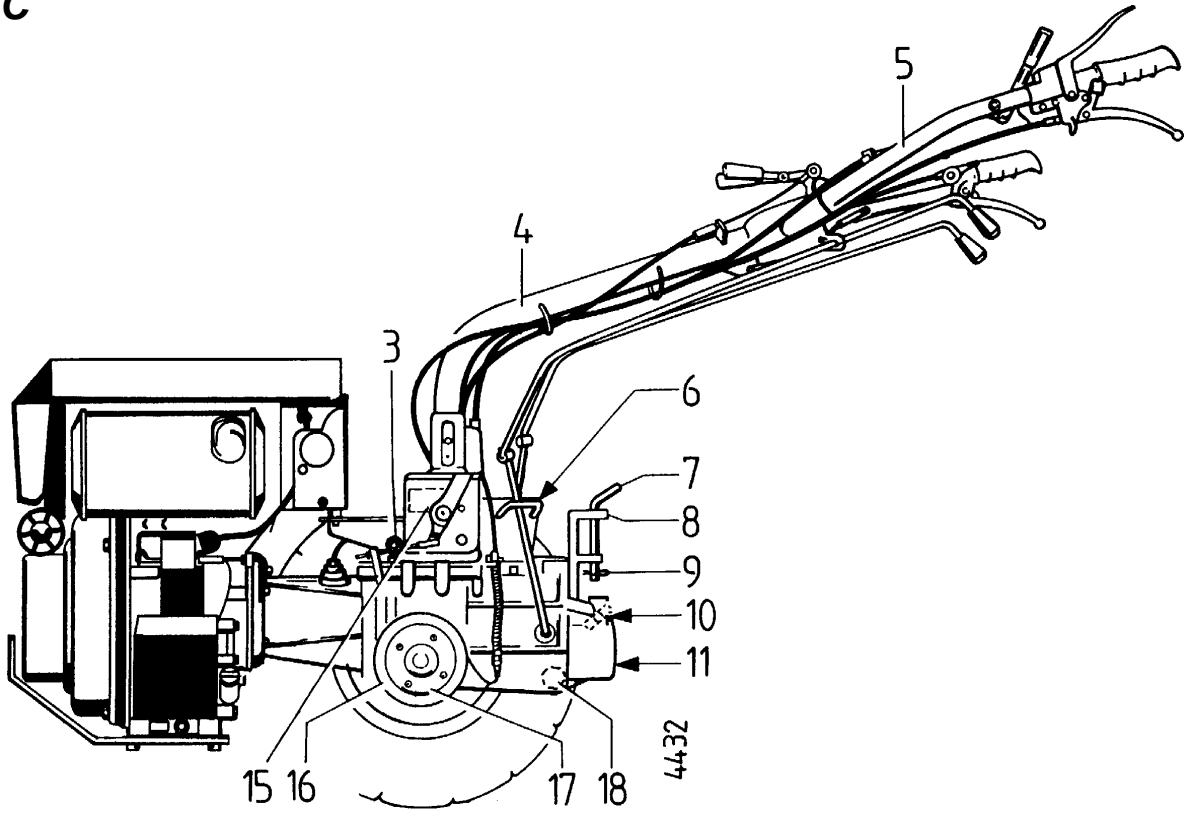

B

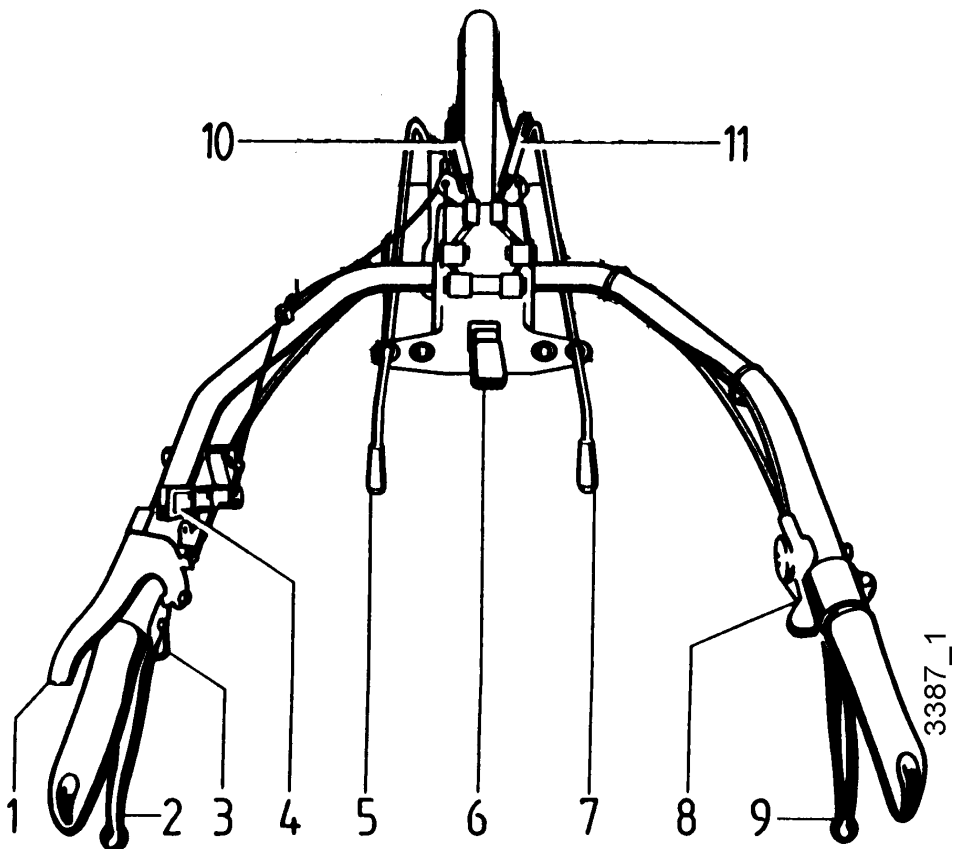

Figure C:

- 3 Oil filling opening of drive gear
- 4 Steering bar
- 5 Handlebar
- 6 Reversing lock
- 7 Lock pin
- 8 Clevis
- 9 W-clip
- 10 Locking lever for attachment coupling
(on the right, seen in travel direction)
- 11 Attachment coupling point with integrated PTO
- 12 Weight support and engine hoob guard
- 13 Support leg
- 14 Engine
- 15 Name plate (on the right, seen in travel direction)
- 16 Single wheel brake
- 17 Wheel flange
- 18 Transmission oil drain plug (on the right, seen in travel direction)

Figure B:

- 1 Safety lever
- 2 Hand lever for engine clutch
- 3 Pawl for engine clutch hand lever
- 4 Hand lever for differential lock
- 5 PTO shifter
(with steering handle swivelled [front attachment] = Gear shifter)
- 6 Locking lever for steering handle side adjustment
- 7 Gear shifter
(with steering handle swivelled [front attachment] = PTO shifter)
- 8 Speed adjustment lever
- 9 Handle lever
- 10 Hand lever for steering brake, left
- 11 Hand lever for steering brake, right

Petrol Engine Robin EH 25 D

This engine runs smoothly on conventional **unleaded regular and supergrade petrol** as well as on **leaded supergrade petrol**.

Do not add oil to petrol.

If, for environmental reasons, you use unleaded petrol, make sure the fuel is drained completely when shutting down the engine for more than 30 days. This is to prevent resin residue from depositing in the carburetor, fuel filter, and tank. Or add a fuel stabilizer to the fuel.

For further instructions see "Engine Preservation".

Diesel Engine Yanmar L100 AE

This Diesel engine runs on conventional Diesel fuel of a min. cetane rating of 45.

Do not use Diesel fuel oil substitutes, they may be harmful to the fuel system. Fuel should be free of water or dust.

Winter operation:

To ensure reliable winter operation use "winter diesel fuel", to be purchased at filling stations.

At outside temperatures of below -15°C, take the following additional precautions:

add commercial flow conditioners

or

add paraffine oil to depress diesel pour-point:

Paraffine oil:	winter diesel fuel	summer diesel fuel
	pour-point	
50%	app. -31°C	app. -25°C
30%	app. -26°C	app. -15°C
10%	app. -20°C	app. -9°C

As a last resort, you can add up to 30% of regular petrol to avoid paraffine deposits. However, this has negative effects on consumption rate and performance.

Instructions for Unpacking and Assembly **agria**

①

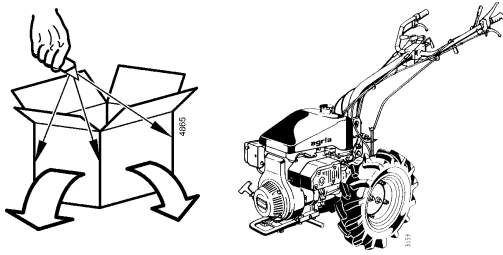

- ① Open top of cardboard box.
- Cut along all four corners of the box and fold down the sides.

② Move the reverse gear lever (4) backwards.

- Fit the steering handle (1) onto the pin (3) of the steering column.

Make sure that Bowden cables 2a are routed on the right side of the steering column and Bowden cables 2b and 2c on the left side of the steering handle (seen in travel direction).

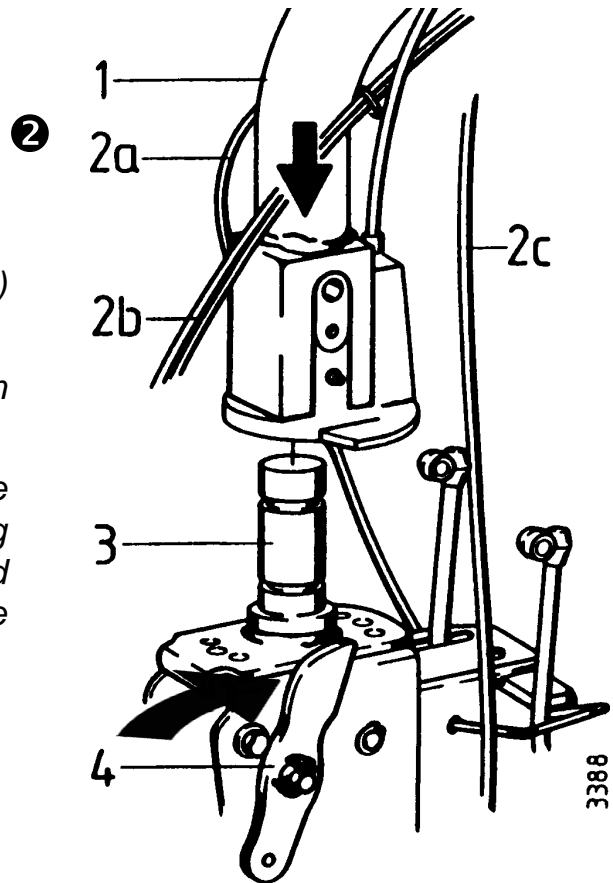

③

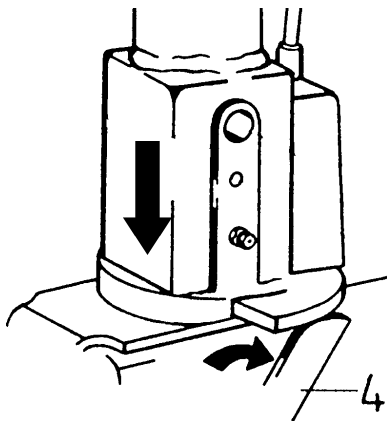

- ③ Press the steering handle all the way down until it rests on the surface of the steering column. Before, push the reverse gear lever (4) all the way back. Use a screw driver or similar tool.

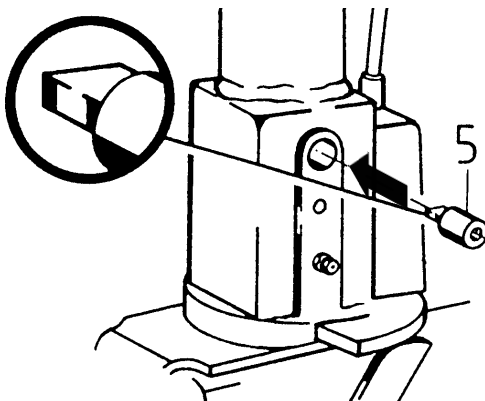

Insert steering handle retaining pin (5) into the hole on the steering column. Hold the flat pin end **horizontally**.

Instructions for Unpacking and Assembly **agri**a

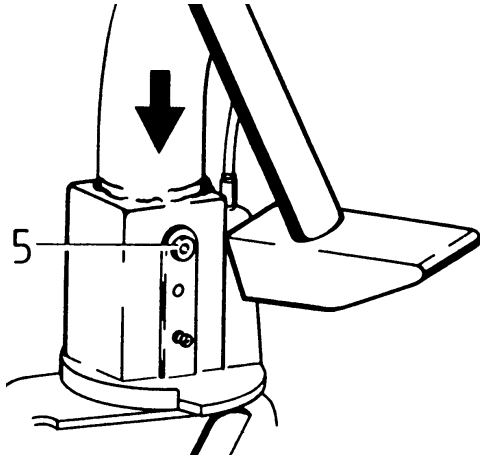

● Carefully hammer the steering handle retaining pin into the steering column until it is flush with the column.

If it is not possible to hammer the pin flush into the steering column, the steering handle may not rest on the surface of the steering column or the flat end of the pin (5) is not horizontal.

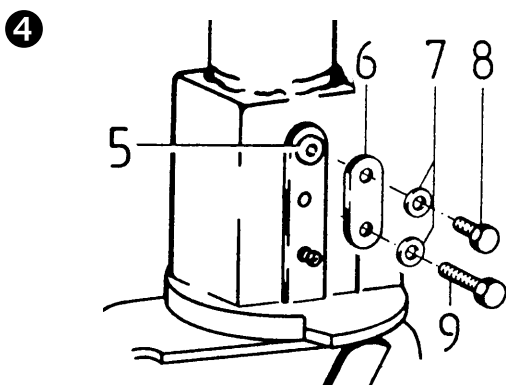

④ Bolt down the retaining pin (5) with bolts and washers 6–9. (Tighten bolts at a torque of approx. 10 Nm).

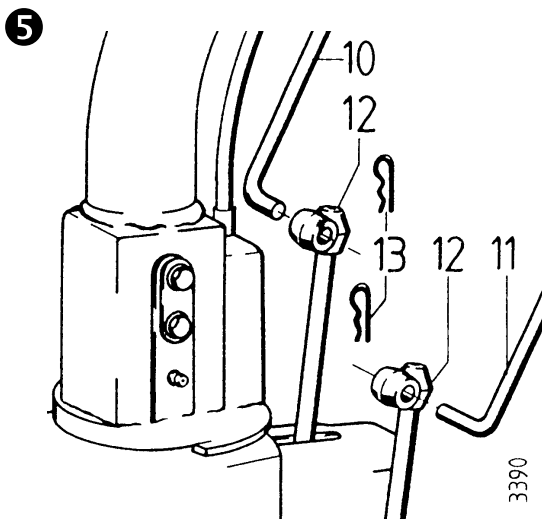

⑤ Fit the shifters (10, 11) into the joints (12) and secure each shifter with a W-clip (13).



⑥ Check Bowden cables to ensure they are not bent and squeezed.

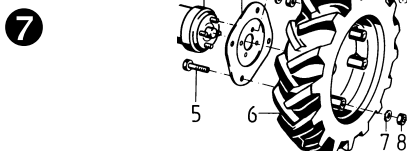

⑦ Fit drive wheels (accessory).



⑧ Carry out all steps for starting-up

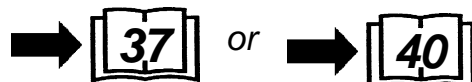

Before starting the engine, read the operating instructions and note:

1

Warning



This symbol marks all paragraphs in these operating instructions which affect your safety. Pass all safety instructions on to other users and operators.

Due Use

The two-wheel tractor and the mounted implements authorized by the manufacturer have been designed for all common applications and tasks in farming and forestry, as e.g. soil cultivation and grassland mowing, this includes winter service and ground clearing (due use).

Any other type of operation is considered undue. The manufacturer is not liable for any damages resulting from undue use, for which the risk lies with the user alone.

Due use includes compliance with manufacturer's instructions on operation, maintenance and repair.

Any unauthorized changes to the two-wheel tractor render manufacturer

liability null and void.

General Instructions on Safety and Accident Prevention

Basic Rule:

The respective national accident prevention regulations have to be adhered to, as well as all other generally accepted rules governing operational safety, occupational health and road traffic regulations.

When driving on public roads, you have to observe the current traffic code.

Accordingly, check the two-wheel tractor for road and operational safety each time you take up operation.

Only persons familiar with the tractor and instructed on the hazards of operation are allowed to use, maintain and repair the tractor.

Teenagers younger than 16 years are not allowed to operate the two-wheel tractor!

Only work in good light and visibility.

Operator's clothes should fit tight. Avoid wearing loose fitting clothes. Wear solid shoes.

Note the warning and instruction signs on the tractor for safe operation. Comply for your own safety.

When transporting the tractor on vehicles or trailers outside the area to be cultivated, ensure that the engine is turned off.

Careful with rotating tools – keep at a safe distance!

Beware of coasting tools. Before you start any maintenance or repair on them, wait until tools have come to a complete stop.

Foreign powered parts shear and crush! Riding on the attachment during operation is not permitted.

Mounted or trailed attachments affect the tractor's driving, steering, braking, and tipping characteristics. Therefore, ensure that steering and braking functions are sufficient. Match operating speed to conditions.

Do not change settings of governor. High engine speed increases risk of accidents.

Working Area and Dangerous Area

The user is liable to third parties working within the tractor's working range.

Staying in hazardous area is not permitted.

Check the immediate surroundings of the tractor before you start it. Watch out for children and animals.

Before you start work, clear the area from any foreign object. During operation, always watch out for further objects and remove them in time.

For operation in enclosed areas, ensure that a safety distance is kept to enclosures to prevent damage to tools.

Operation and Safety Devices

Before you start the engine

Become familiar with the devices and operating elements and their functions. Above all, learn how to turn the engine off quickly and safely in an emergency.

Ensure that all protective devices are mounted and positioned to provide protection.

With no attachment mounted, make sure PTO-shaft is covered with the protective cap.

Starting the engine

Do not start engine in closed rooms. The carbon monoxide contained in the exhaust fume is extremely toxic when inhaled.

Before you start the engine set all operating elements to neutral or idling position.

When starting the engine, do not step in front of the two-wheel tractor and the attachment.

Do not use assist-starting liquids when using electrical assist-starting devices (jumper cable). Danger of explosion.

Operation

Never leave the operator's position at the steering handle while tractor is at work.

Never adjust the handles during work - danger!

1. Safety Instructions

1

During operation do not leave the operator's position at the steering handle, especially not when you turn the machine.

Riding on the attachment during operation or in transport is not permitted.

If clogging occurs in the attachment, turn off the engine and clean the attachment with an appropriate tool.

In case of damage to the two-wheel tractor or to the attachment, immediately turn off the engine and have it repaired.

If steering causes problems, immediately bring the two-wheel tractor to a halt and turn it off. Have the malfunction removed without delay.

To prevent the tractor from slipping in hillside operation, make sure it is secured by another person who uses a bar or a rope to hold the tractor. This person has to be located at a higher position than the vehicle and at a safe distance from the tools at work.

If possible, always work diagonally to the slope.

End of Operation

Never leave the two-wheel tractor unattended with the engine running.

Before you leave the two-wheel tractor, turn off the engine. Then close fuel taps.

Secure the two-wheel tractor against unauthorized use. If tractor is equipped with an ignition key, remove the key. For all other versions, remove the spark plug connector to secure the tractor.

Attachments

Only mount attachments with the engine and PTO switched off.

Always use appropriate tools and wear gloves when changing attachments and parts thereof.

To fitt and remove attachments, bring the support leg into proper position and ensure stability.

Secure the two-wheel tractor and attachments against rolling off (parking brake, wheel chocks).

Beware of injuries while coupling attachments.

Couple the attachments as specified and only couple at specified points.

Secure the two-wheel tractor and attachment against unauthorized use and rolling off when you leave the machine. If necessary, install transport or security devices and secure them.

Hoeing Attachment

Adjust the protective covers in such a way that only the hoeing tools penetrating the soil are not covered.

When hoeing, make sure the hoeing skid is adjusted properly.

1. Safety Instructions

Mowing Attachment

Handle with care! Sharp blades of the cutter bar may cause injuries when handled improperly! Remove protective knife strips only for mowing and refit immediately after work has finished.

For transport and storage always fit the protective knife strips. Secure finger bars additionally with tension springs.

Do not transport the removed cutter bar without protective strips.

When fitting/removing the cutter bar, make sure all blades are protected by the knife strip.

To exchange the knife and to fit/remove the knife driver, make sure that you turn screws and bolts away from the cutting blades to remove them.

To grind the mowing knives, always wear safety goggles and gloves.

Trailer

Make sure to not exceed permissible tongue load of trailer coupling, drawbar or hitch.

When coupling the drawbar, make sure manoeuvrability at coupling point is sufficient.

Do not exceed gross axle weight rating, towing capacity and gross weights.

Before driving, check brake function and rear lighting for proper operation.

Regularly check brake systems closely.

Have adjustments and repairs on the brake system only carried out by a professional workshop or an authorized brake service station.

When driving with a trailer mounted, make sure single-wheel braking is not used.

On tractors equipped with single-wheel gear-shift do not engage single-wheel shift – single-wheel shift must be locked!

On tractors equipped with differential lock; do not use differential lock when driving in curves.

Only one passenger may ride on the trailer, provided a safe passenger seat is available.

No additional passengers may be carried.

When driving downhill, shift into lower gears in time. On slopes never de-clutch to change gears.

Weights

Always fit weights properly and at specified points.

Maintenance

1

Never carry out any maintenance or cleaning while the engine is running.

Before you work on the engine, always remove spark plug connector (petrol engine only).

Check regularly and, if necessary, replace all protective devices and tools subject to wear and tear.

Replace damaged cutting tools.

Always wear safety gloves and use proper tools when exchanging cutting tools.

Do not carry out repairs like welding, grinding, drilling, etc. on structural and safety-relevant parts (e.g. coupling devices)!

Keep the two-wheel tractor and the attachment clean to avoid risk of fire.

Check nuts and bolts regularly for tight fit and re-tighten, if necessary.

Ensure that you re-install all safety and protective devices and adjust them properly after maintenance and cleaning.

Only use original agria spare parts. All other conventional spare parts must correspond to quality and technical requirements specified by agria.

Storage

It is not allowed to store the two-wheel tractor in rooms with open heating.

Never park the two-wheel tractor in closed rooms with fuel left in tank. Fuel vapours are hazardous.

Engine, Fuel, and Oil

Never let the engine run in closed rooms. Extreme danger of intoxication! For the same reason, also replace damaged exhaust pipes immediately.

Be careful when dealing with fuel. Great danger of fire! Never refill fuel close to open fire, inflammable sparks or hot engine parts. Do not refill fuel in closed rooms. Do not smoke when refilling!

Refill only with the engine switched off and cooled down.

Do not spill any fuel, use a proper filling device.

In case of fuel-spillage, pull the two-wheel tractor away from the spillage before you start the engine.

Make sure fuel is of specified quality.

Store fuel in approved cans only.

1. Safety Instructions

Liquids leaking under high pressure, e.g. fuel, can penetrate the skin and cause severe injuries. Immediately see a doctor.

Store anti-corrosive agents and stabilizing liquids out of reach of children. If sickness and vomiting occur, see a doctor. If fuel has contacted eyes, rinse them thoroughly, avoid inhaling of vapours.

Read and observe enclosed instructions.

Before you dispose of opened and seemingly empty pressurised tins (e.g. of assist-starting liquids) make sure they are completely empty. Empty them in ventilated places safe from spark formation or flames. If necessary, dispose of tins in hazardous waste deposits.

Be careful when draining hot oil, danger of burns.

Make sure oil used is of specified quality. Storage is in approved cans only.

Dispose of oil, greases, and filters separately and properly.

Tyres and Tyre Air Pressure

When working on the tyres, make sure the two-wheel tractor is parked properly and secured against rolling off.

Any repairs are to be carried out by trained mechanics only and with the appropriate tools.

Regularly check air pressure in the tyres. Excessive pressure may cause bursts.

When adding weight, make sure the air pressure in the tyres is correct.

Re-tighten fastening bolts of drive-wheels or check tightness when doing maintenance work.

Electrical System and Battery

When working on the electrical system, make sure the battery is disconnected (negative terminal) (for tractors equipped with battery).

Make sure to connect the battery properly - first connect the positive terminal and then negative terminal. Disconnect in reverse order.

Be careful with battery gases- explosive!

Avoid spark discharge and open flames near batteries.

Remove plastic cover (if equipped) to recharge battery and to prevent highly explosive gases from building up.

Careful when handling battery fluid!

Only use specified circuit breakers. If the circuit breakers are too strong, they will destroy the electrical system - danger of fire.

Always cover positive terminal with the specified cover or terminal cap.

Persons having a pacemaker may not touch live parts of the ignition system when the engine is running.

1

Explanation of Warning Signs

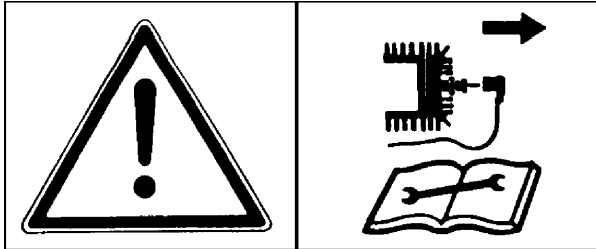

Before any cleaning, maintenance, and repair work switch off the engine and pull spark plug connector.



Do not touch moving machinery parts. Wait until they have come to a complete stop.

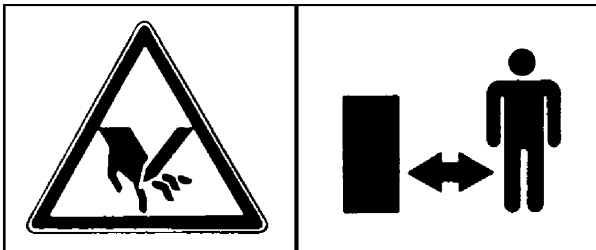

With the engine running, keep at a safe distance from cutting or hoeing tools. Do not work without protective covers

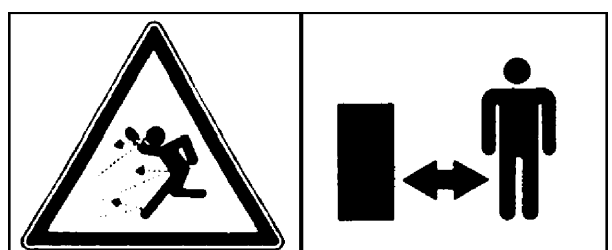

With the engine running, keep at a safe distance from tractor.

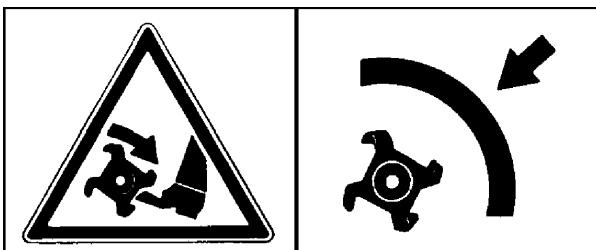

mounted. Before starting the engine, bring covers in proper position.

Signs



When working with the machine, wear individual protective ear plugs.



Wear protective gloves.

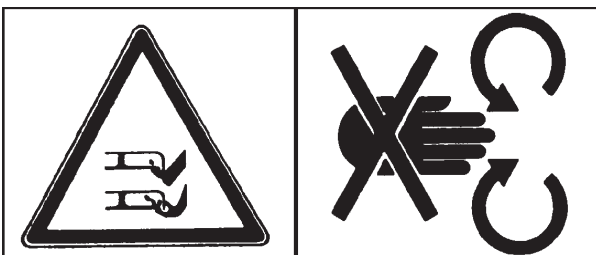

With the engine running, keep at a safe distance from knife.

Two-Wheel Tractor

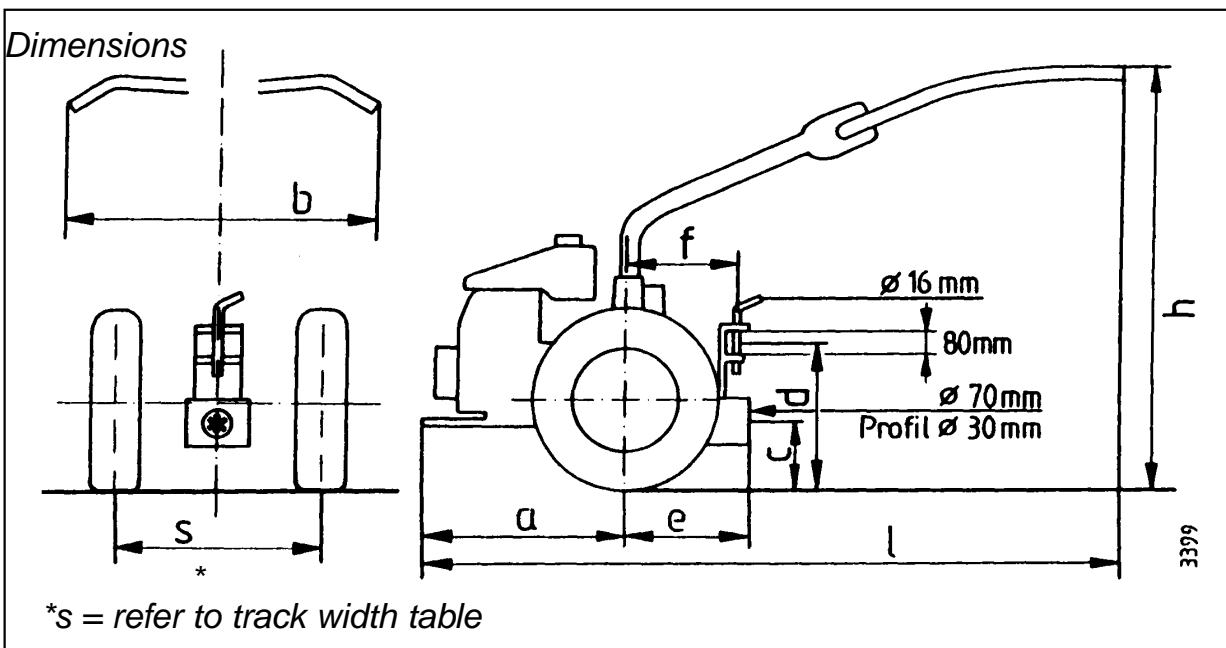

2

		a	b	c	d	e	f	h	l
L100AE	5.0-10	650	570	240	195	300	270	1200	1820
EH25D	5.0-10	580	570	240	195	300	270	1200	1750
L100AE	6.5/80-12	650	570	290	245	300	270	1250	1820
EH25D	6.5/80-12	580	570	290	245	300	270	1200	1750

Tyre: (Accessory)
 3990 111 5.00 -10 field tyre
 3990 411 5.00-12

To fit the drive wheel, see page 31
 Air pressure: 1.2 bar

Track Width Plan: [mm] Tyre: 5.0-10 AS

A	S	i	A	S	i	A	S	i	A	S	S	
490	350	210	510	370	230	530	390	250	590	450	310	5.00-10
									760	600	440	5.00-12

2. Specifications

Petrol Engine

agria

Engine EH 25 D

Manufacturer: Robin

Type: EH 25 D

Version: Fan-air-cooled 1-cylinder-
4-stroke engine (petrol) OHV

Bore: 75 mm

Stroke: 57 mm

Cubic capacity: 251 ccm

Output: 5.9 kW at 3600 rpm

Torque: max 16,7 Nm at 2400 rpm

Spark plug: Bosch WR7AC
NGK BR 6 HS

Spark plug gap: 0.7 mm–0.8 mm

Ignition system:

Contactless electronic magnet
ignition, ignition point is pre-set, radio
remote screened according to VDE
0879

Valve lash (engine cold):

Intake: 0.08 mm–0.11 mm

Outlet: 0.08 mm–0.11 mm

Starter: Recoil starter

Fuel tank capacity: approx. 8 l

Fuel: Commercial petrol
octane number min. 90 RON
(refer to fuel recommendations)

Air filter: Dry filter element
with foamed preliminary filter

Carburetor: Horizontal float
carburetor

Mix control screw:

in basic setting approx. 1/4 revs. open
main jet
idling jet

Rated speed: 3600 rpm

Top no-load speed: 3800 rpm

Idling speed: 1200 rpm

Engine oil:

Filling quantity approx. 0.65 l
Multi-grade oil SAE 10 W-40 API-SC
or higher quality

Noise level:

In accordance with German 3rd
Ordinance on machine-safety law:

Noise level

at operator's ear 87 dB(A)
(in accordance with regulations of
German Agricultural Association)

Sound level: 99.5 dB(A)
in accordance with EC 84/538/EEC at
85% of engine speed

Operability on Slopes:

Engine is suited for use on slopes (with
oil level at "max" = upper level mark)

Continuous operation possible
up to 45° inclination (100%)

2

2. Specifications

Diesel Engine

agria

Diesel Engine

Manufacturer: Yanmar

Type:

Recoil starter version L100AE-DI

Version: Fan-air-cooled
1-cylinder-4-stroke diesel engine

Bore: 86 mm

Stroke: 70 mm

Cubic capacity: 406 ccm

Output: 7.4 kW at 3600 rpm

Max torque: 27 Nm at 1700 rpm

Injection pressure: 200 bar

Valve lash (engine cold)

Intake: 0.15 ± 0.02 mm

Outlet: 0.15 ± 0.02 mm

Starter: Recoil starter

Fuel: conventional fuel,
Min. cetane rating: 45
(refer to fuel recommendations)

Fuel filter:

Coarse-mesh strainer in filler neck

Fine-mesh strainer in fuel tank
drain hole

Fuel tank capacity: approx. 5.5 l

Air filter: Dry filter element with
foamed preliminary filter
and cyclone pre-separator

Rated speed: 3600 rpm

Top no-load speed: 3800 rpm

Idling speed: 1700 rpm

Lubrication: Pressure lubrication
via gear pump
Full flow oil filter

Engine oil:

Filling quantity approx. 1.65 l
Multi-grade oil

at ambient temperature -15° to $+45^{\circ}\text{C}$:
SAE 10W-40 API-SC (or higher)

at ambient temperature -25° to $+15^{\circ}\text{C}$:
SAE 5W-20 API-SC (or higher)

Noise level:

Noise level

at operator's ear 88 dB(A)
(in accordance with EN 709)

Acoustic power level: 99 dB(A)
in accordance with EC 84/538/EEC at
85% of engine rated speed

Operability on Slopes:

Engine is suited for use on slopes
(oil level at "max" = upper mark)

Continuous operation possible
up to 20° inclination (44%)

2

The two-wheel tractor agria 3900 is a powered basic machine and is always operated with an attachment mounted.

Available attachments (among others):

- Rear attachments for
 - hoeing and tilling
 - draft attachments for soil cultivation
 - two-wheel trailers
 - gravel and salt spreading
- Front attachments for
 - mowing
 - sweeping
 - snow clearing and tilling
 - gravel and salt spreading

For a choice of further attachments refer to our price-list.

Engine

- The **four-stroke petrol engine** runs on commercial petrol (refer to fuel recommendations p9).

Ignition System

The engine is equipped with a contact-less ignition system. We recommend to have necessary check-ups done by an expert only.

- The **four-stroke diesel engine** runs on conventional diesel fuel or rape oil (refer to fuel recommendations p9). See to using proper fuel in winter.

During the first 20 operating hours (break-in period) do not use engine to maximum power.

Even after break-in period never use engine at higher speed than necessary for the work in hand.

i High engine speed is harmful to any engine and considerably affects its durability. This applies especially for no load operation. Any overspeed (have the engine roar) can result in immediate damage.

Cooling System

Cooling system is fan-cooled. Therefore keep screen at recoil starter and cooling fins of cylinder clean and free from sucked-in plant trash.

Idling Speed

Always ensure that idling-speed is adjusted correctly. At low speeds and with the speed control lever set to idle, the engine is supposed to run smoothly and without run-out.

Air Filter

The air filter purifies the air intake. A clogged filter reduces engine output.

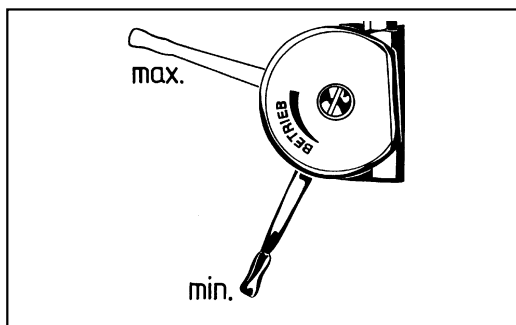

Speed Control Lever

Petrol engine

The speed control lever (B/9) on the steering handle is for stepless setting of engine speed from min. = idle to max. = full throttle.

Diesel engine

The speed control lever (B/9) on the steering handle is for stepless setting of engine speed from min. = idle to max. = full throttle. For settings refer to Fig. J.

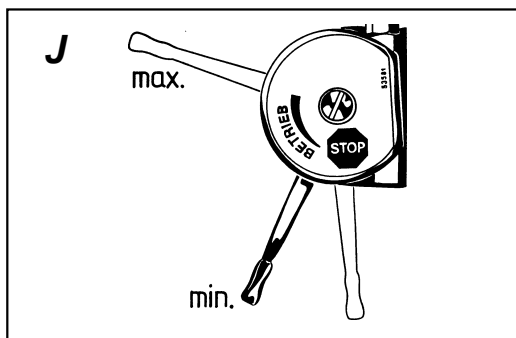

i The engine speed control lever also serves **to shut off the engine in an emergency**. It then goes into STOP position.

3

Safety Circuit

The two-wheel tractor is equipped with a safety lever (lever B/1).

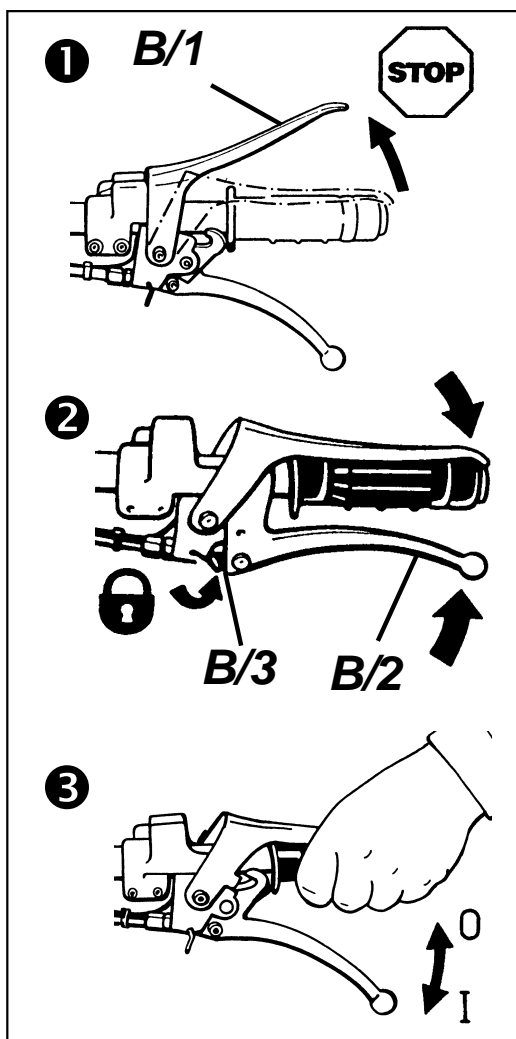

1 Stop position: When releasing the lever (B/1), the engine is shut off. Beware – engine keeps running due to centrifugal mass!

2 Start position: For starting the engine and for short breaks, press the safety lever (B/1), pull the the clutch lever (B/2) and lock with pawl (B/3).

3 Operating position: For machine operation, press safety lever (B/1).

! Do not fasten safety lever.

i The safety lever also serves **to switch off in an emergency**. Release the safety lever for fast engine switch-off. The lever automatically goes to STOP position.

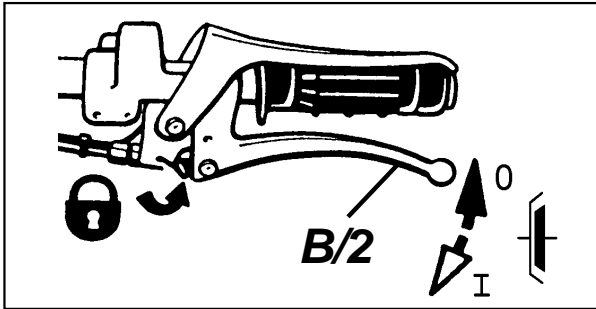

Clutch

The tractor is equipped with a double disc dry clutch which is operated via the hand clutch lever (B/2). When the hand clutch lever is pulled, the clutch is decoupled, i.e. the engine stops driving the two-wheel tractor.

- Watch for the correct clutch play to avoid clutch slipping away during operation.

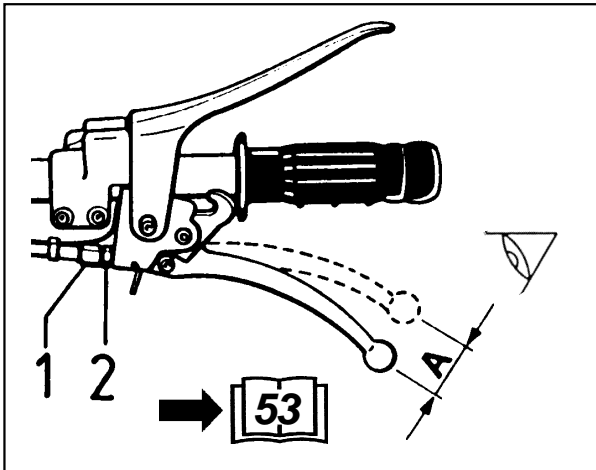

3

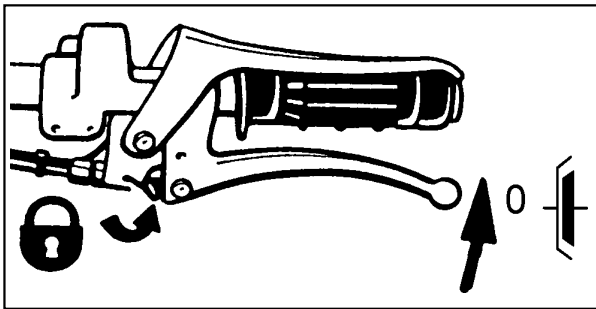

- ⓘ **With the engine running,** do not park the tractor for an extended period of time while the clutch is pulled because this may result in damage to the clutch release bearing.

With **the engine stopped,** always park the two-wheel tractor with the hand lever pulled (pawl is locked into place), otherwise clutch problems may occur due to corrosion.

Gearbox

i Only change gears when the machine is not travelling and when it is decoupled.

With the steering handle swivelled 180° (for front attachment), the gear shifters for transmission and PTO have changed sides → **34**

3

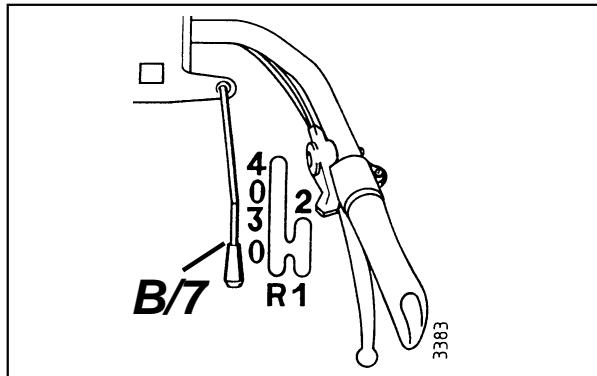

Gearshifting

Gears are engaged via gear shifter (B/7).

Between two gears there is a neutral position.

The position of the shifter in the transmission shift gate indicates the gear selected.

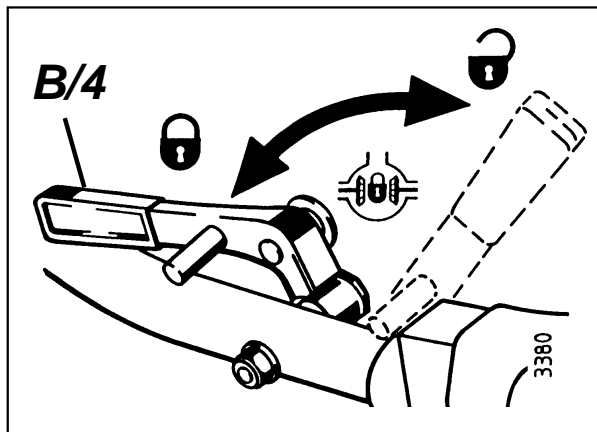

Differential Gear

To improve traction in severe conditions, differential gear can be locked with hand lever (B/4). Keep the differential gear locked only as long as it is necessary.

i As the steering of the tractor is easy, you should disengage the differential lock when driving with a trailer mounted (especially in curves).

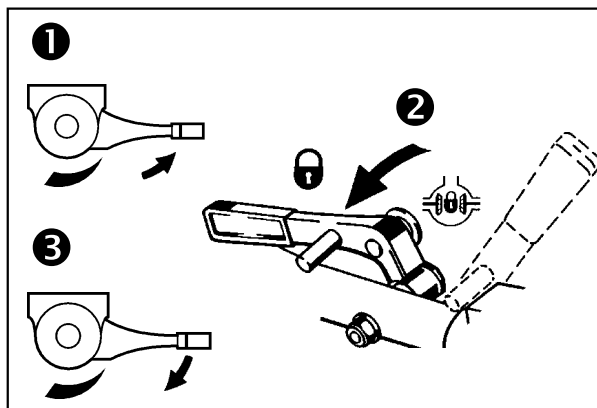

Engaging differential lock

(rigid wheel shaft)

On the go:

- 1** Release the throttle
- 2** Move the hand lever for differential lock (B/4) forward
- 3** Press the throttle accordingly

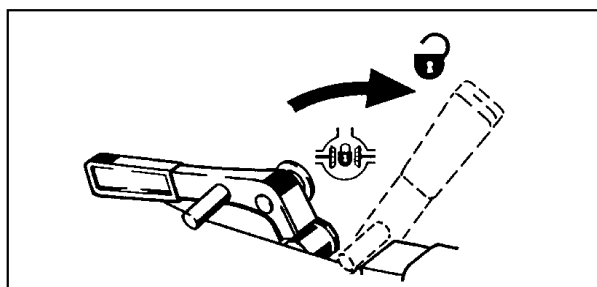

Disengaging differential lock

- Move the hand lever (B/4) for differential lock backward

Single-Wheel Brake

(Turning assistance)

The two-wheel tractor is equipped with a single-wheel brake system for easier steering or turning. This system allows the brake to be engaged on either the left or the right wheel separately, as required.

Engage the brakes via the hand levers (B/10 or B/11).

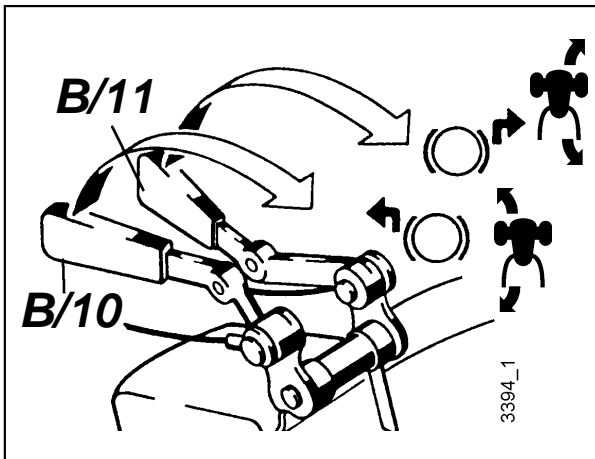

- To turn right, pull hand lever (B/11).
- To turn left, pull hand lever (B/10).

3

! With the steering handle swivelled 180° (f or front attachments), turning procedure is vice versa.



When turning on banks, always turn the machine towards the slope.

! When driving with a trailer mounted, do not use the tractor's single-wheel brake but the operating brake of the trailer.

Central Brake

To slow down or park the on slopes, use the combined central hand brake. For this connect the hand levers with the linch pin.

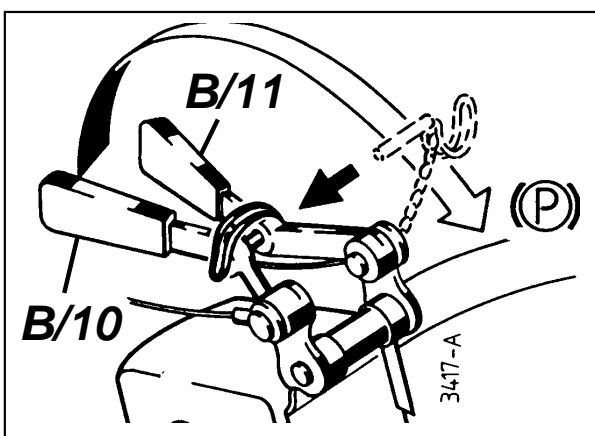

● Central Brake

Clockwise swivel the hand lever (B/10 and 11) backwards – brakes act on both drive-wheels.

Release the hand lever and the lever swivels back to the original position – the brake is released.

● Hand Brake

Clockwise swivel the hand lever (B/10 and 11) backwards beyond the dead centre.

The hand lever automatically comes to a stop – both drive-wheels are locked. To release the hand brake, swivel the hand lever back to original position – the brake is released.

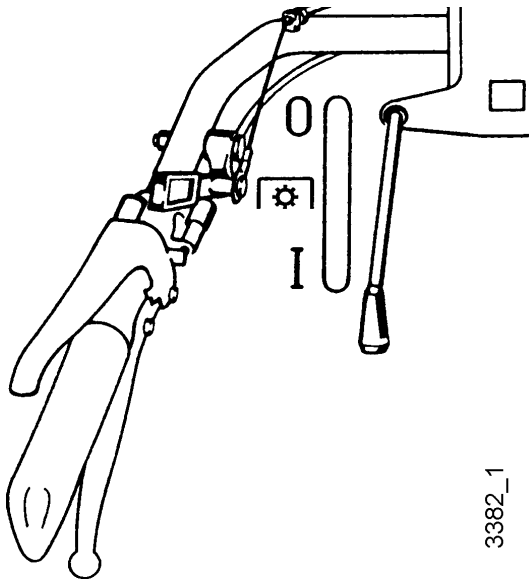

3382_1

PTO drive

The gear independent PTO (A/11 and C/11) is integrated into the coupling flange of the two-wheel tractor.

PTO is turned on/off via the PTO shifter (B/5). Only change PTO speed **when the machine is decoupled**:

- I = PTO on,
pull PTO shifter backward
- 0 = PTO off,
push PTO shifter forward

i When the steering handle is swivelled 180°, the PTO shifter and the gear shifter change sides. Now you change PTO speed in opposite direction

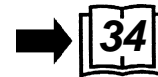

Reversing Lock, PTO Lock

The two-wheel tractor is equipped with an automatic reversing lock (A/6) (Locking lever ①). This prevents the PTO for the hoe from being engaged while the tractor is in reverse. It also prevents the reverse gear from being engaged while the PTO is at work.

3

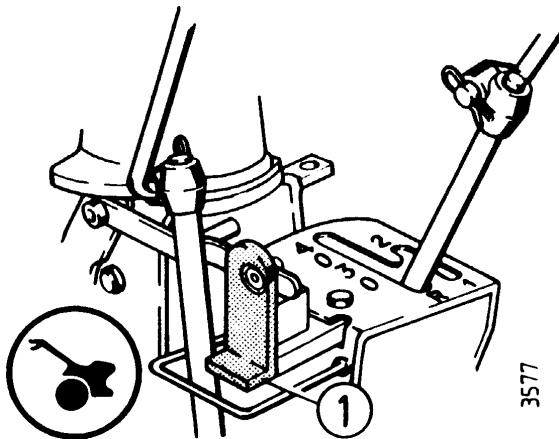

3577

Rear attachments:
Reverse gear is engaged
– pto engagement is locked

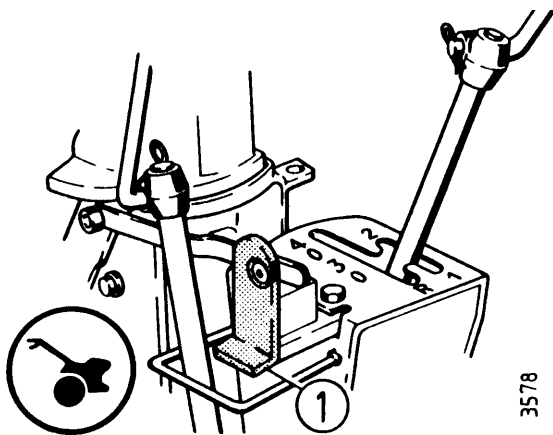

3578

Rear attachments:
Machine is in neutral or in forward gear
– pto engagement is unlocked

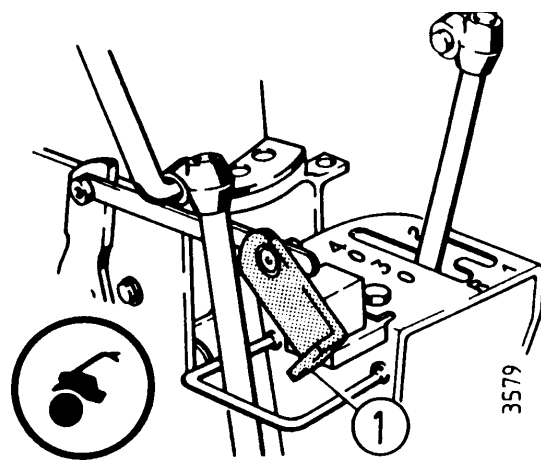

3579

Front attachments:
Pto engagement is unlocked for all speeds

Steering Handle

 Only adjust the steering handle when the machine is in idle or off.

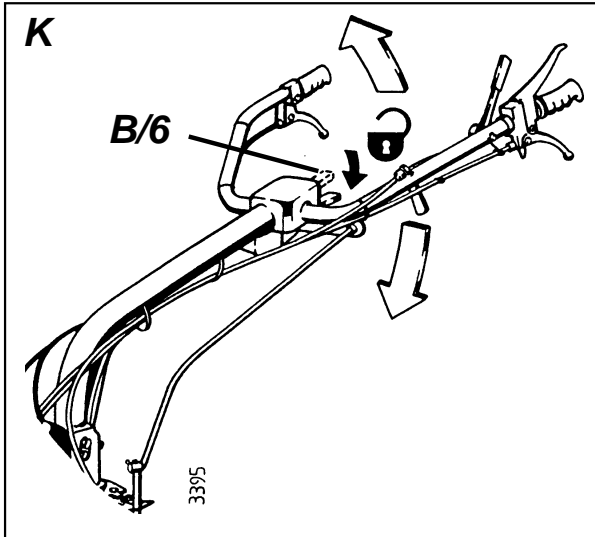

Steering Handle Height Adjustment

- Press down locking lever (B/6), until notches are free.
- Adjust handlebar to desired height (fig. K).
- Release locking lever and fit handlebar into proper notch, in such a way that the locking lever swivels back into its original position.

3

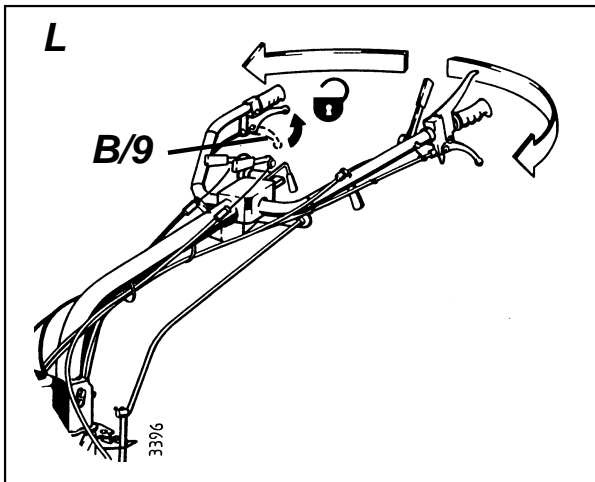

Steering Handle Side Adjustment

you can swivel the steering handle from its normal position (centre position) approx. 30° to the left or right (fig. L).

- Pull handle lever (B/9) and swivel the steering handle to the left or right and into the desired position.
- Release handle lever (B/9) and lock into an appropriate notch on the steering handle.

3

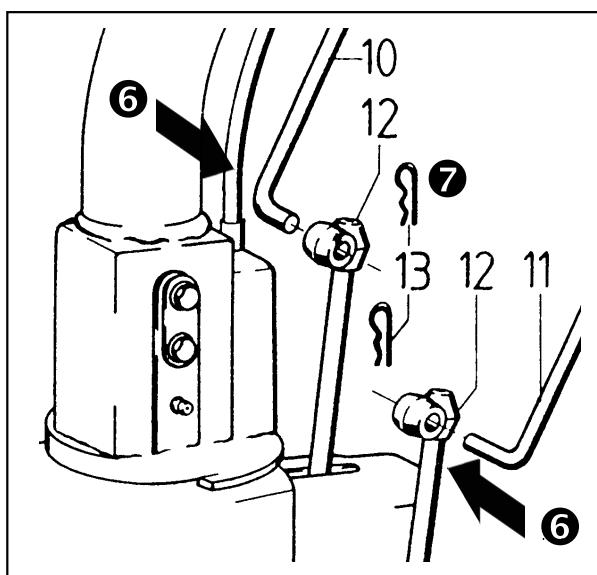
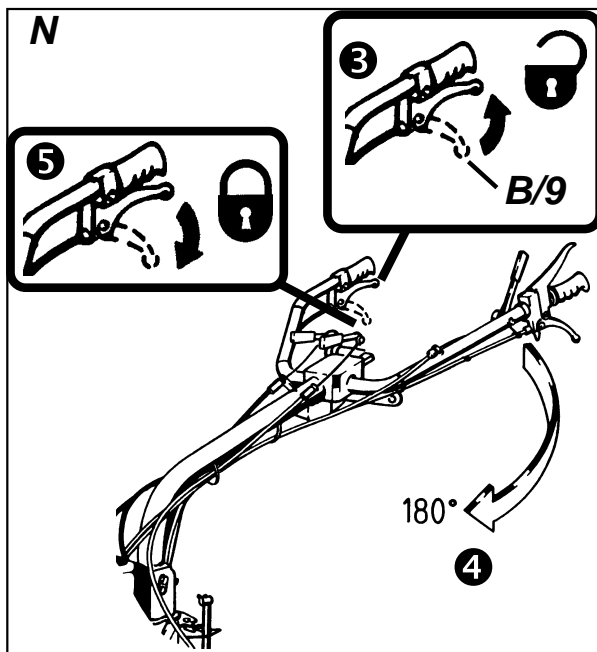
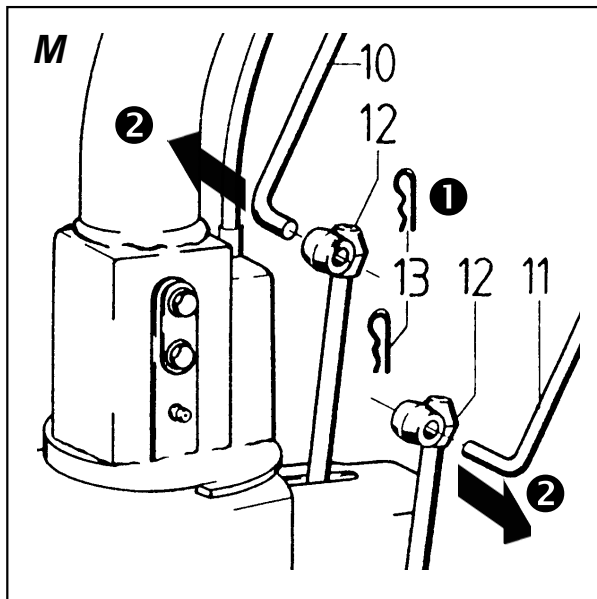

Swivel Steering Handle – 180°

For mounting front attachments, swivel the steering handle 180°.

⚠ Only swivel the steering handle when the engine is turned off.

1 Remove W-clips (M/13) from shifters.

2 Remove shifters (M/10 + 11) from joints (M/12).

3 Pull the handle lever (B/9).

4 At the same time swivel the steering handle clockwise 180° (fig. N).

5 Release handle lever and lock it into an appropriate notch on the steering handle.

6 Reconnect both shifters with outer shift levers.

7 Secure with W-clips.

i Make sure Bowden cables are not twisted or strained when you swivel the steering handle.

The gear shifter is now located on the left side and the PTO shifter on the right side of the steering handle.

In addition, PTO speed shifting and single-wheel braking is now into the opposite direction



Steering handle side adjustment (approx. 30°) is also possible with the steering handle swivelled for front attachments.

Swivel Steering Handle Back to Original Position

To swivel steering handle back to its original position, proceed in the same order, but swivel counter-clockwise.

Drive-Wheels 5.0 - 10

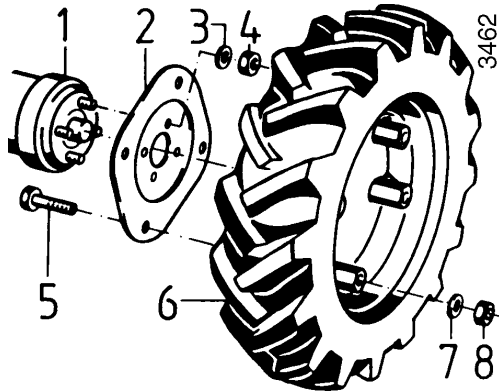

Drive-Wheels 5.00 - 12

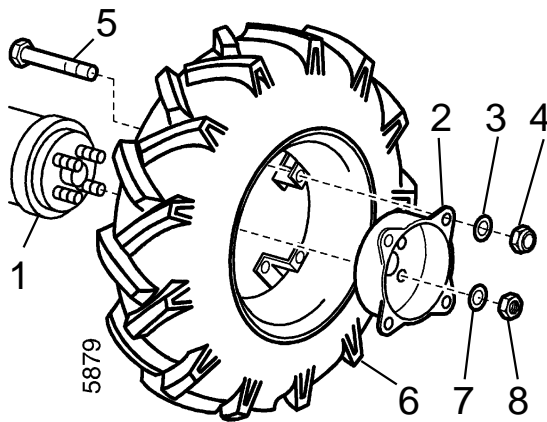

- 1 Wheel flange
- 2 Wheel adapter flange
- 3 Washer
- 4 Wheel nut
- 5 Hexagonal bolt
- 6 Drive-wheel
- 7 Washer
- 8 Wheel nut

Wheel Weight 12"

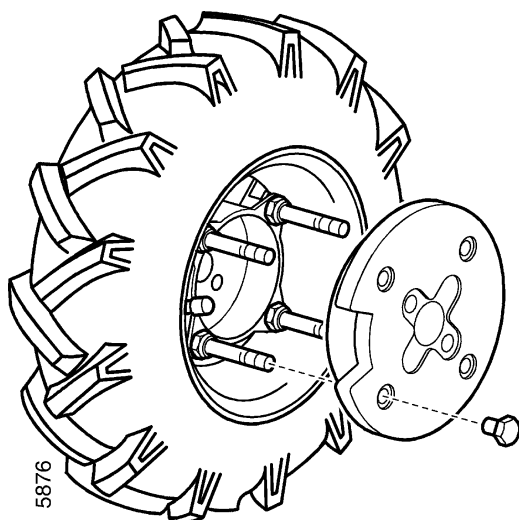

Drive-Wheels

Use wheel nuts (8) to mount the appropriate drive-wheels (6) on the wheel flanges (1).

Before, fit the wheel adapter flanges (2) onto the drive-wheels.

Track width is adjustable to fit requirements (see track width plan p18). For this purpose, mount drive-wheels onto wheel flanges or drive-wheels onto wheel adapter flanges (flanges or wheels turned inward or outward and mounted on their inner or outer sides onto wheel adapter flanges).

For full tractive power, mount wheels with pointed parts of lugs showing in driving direction (wheels seen from above). This applies also when steering handle is swivelled 180° for front attachments.

3

Wheel Fastening Bolts

On new machines and each time you change wheels retighten wheel bolts and wheel nuts at a torque of **50 Nm**. Otherwise tighten bolts and nuts each time you maintain the machine.

Snow Chains

When working with snow chains fitted, observe manufacturer's instructions. Make sure there is sufficient clearance between chains and machine parts.

Front Weight

Only Petrol Engine Version

To improve traction you can fit a front weight.

Fitting

front weight Item No. 3228 011

To fit the front weight onto the tractor equipped with diesel engine and electric starter, you need the front weight support kit (agria No. 719 66).

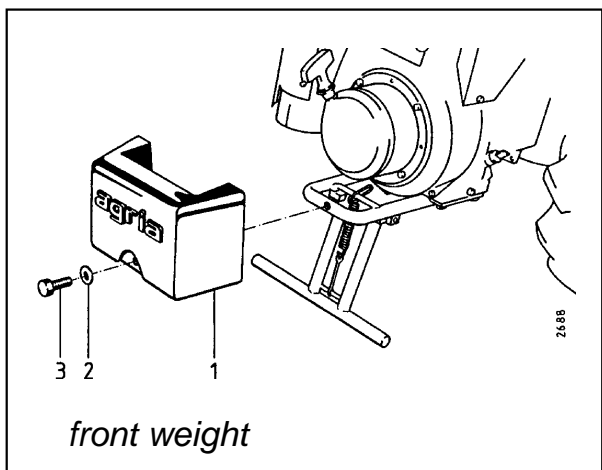

front weight

3

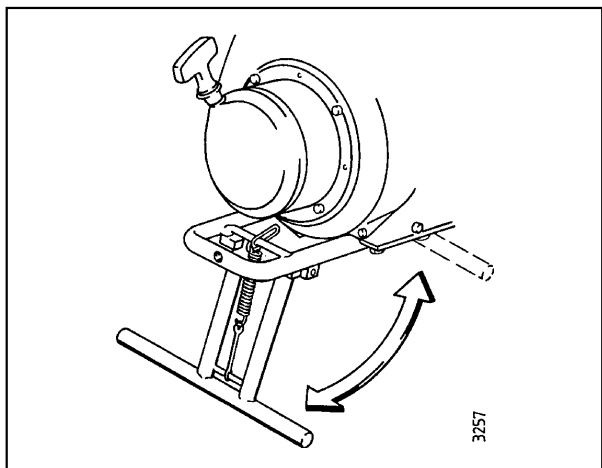

Support Leg

To park the two-wheel tractor with no attachment mounted and to couple attachments more easily, the two-wheel tractor is equipped with a support leg (A/13) which is positioned at the front under the engine hoob guard. To park the tractor, push the leg down and forward. For working, push it back up.

Coupling and Decoupling Attachments

Rear Attachments

⚠ *Mount and remove attachments only with engine switched off!*

Coupling attachments

1 Remove plastic cap from attachment coupling pin.

2 Ensure that coupling surfaces on two-wheel tractor and attachment are clean and greased. Clean and grease, if necessary.

3 Set gearshift to "0".

4 For PTO driven attachments, set PTO shifter (B/5) on two-wheel tractor to position "0".

5 Turn locking lever (A/10; C/10) to position open "🔓".

6 Push attachment in to stop shoulder

7 Turn locking lever (A/10; C/10) to position closed "🔒".

The locking bolt locks automatically. If not, twist and turn the attachment slightly to the left and right.

Decoupling attachments

1 Turn locking lever (A/10; C/10) to position open "🔓".

2 Decouple attachment.

3 Refit cap onto attachment coupling pin.

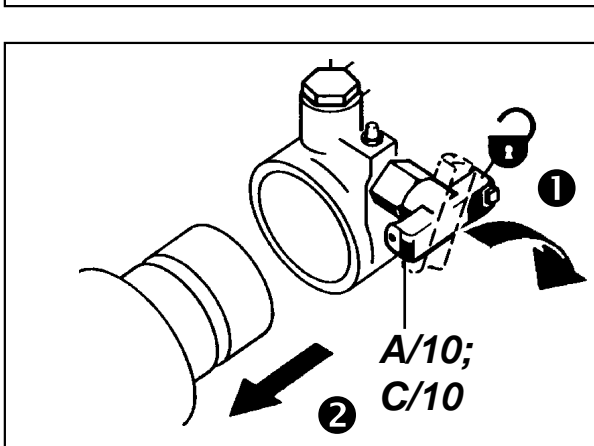
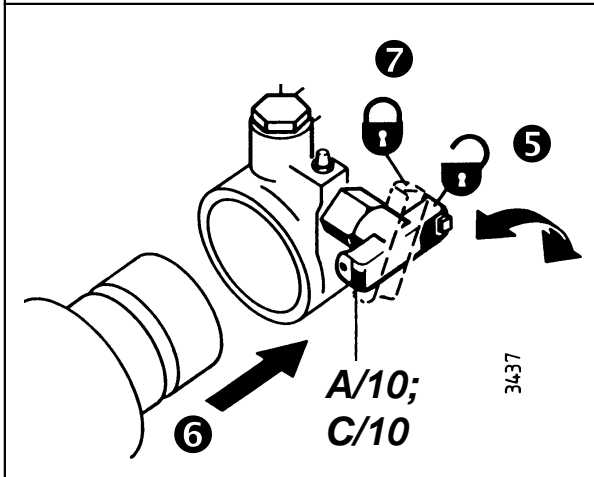
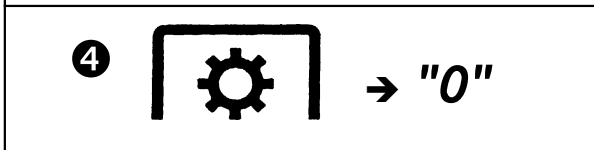
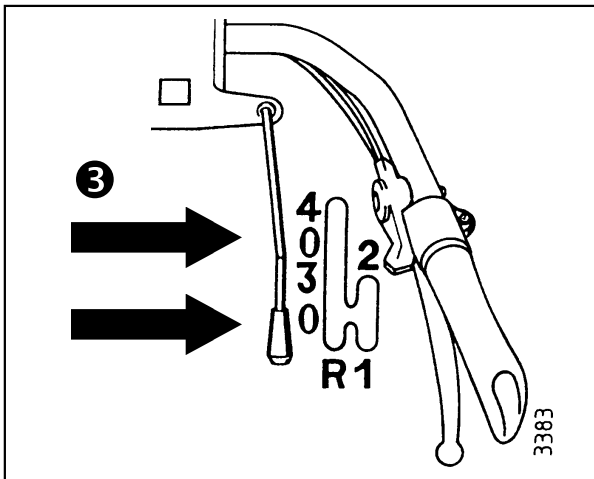

3

Front Attachments

To use the two-wheel tractor with front attachments (e.g. mowing, snow clearing, etc.) swivel the steering handle clockwise 180°:

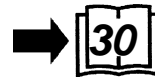

3

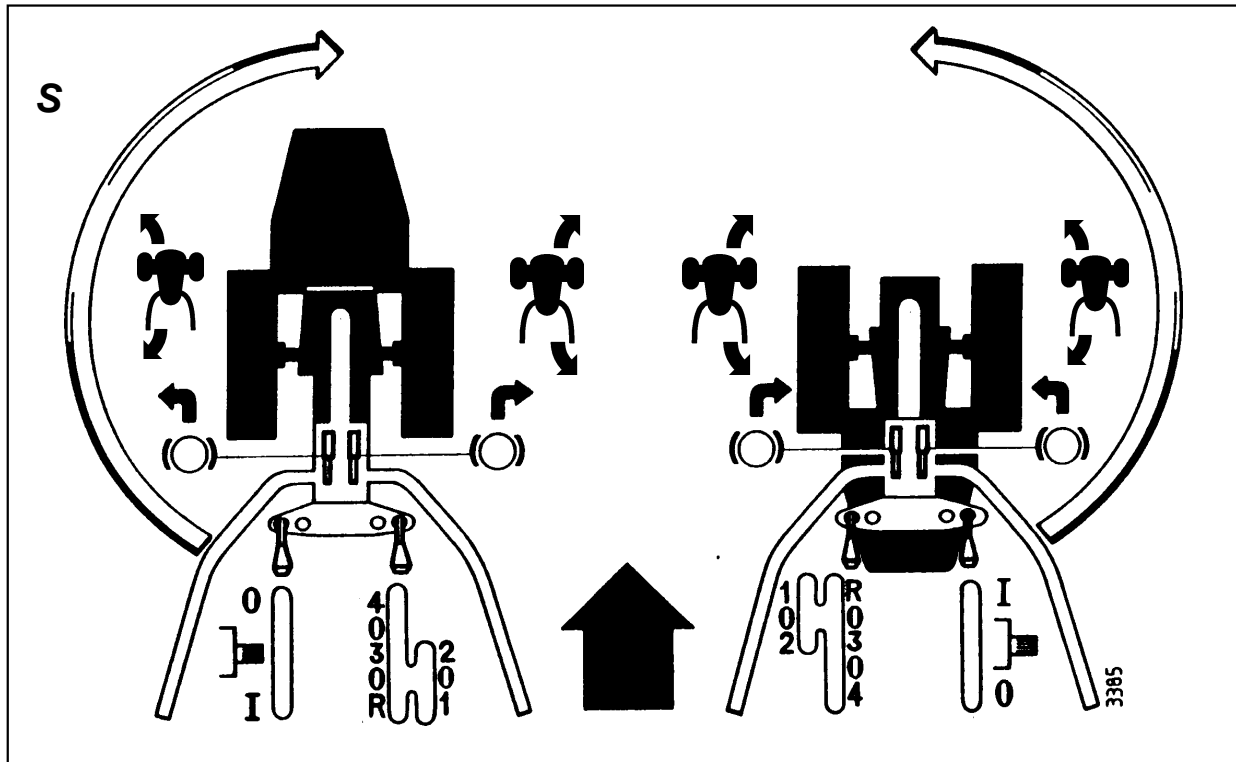

i The gear shifter is now to the left and the PTO shifter is to the right of the steering handle. Speed shift positions are vice versa (Fig. S). In addition, hand lever 1 (see fig. S) now brakes the right wheel and vice versa.

i Each time the steering handle is swivelled 180° for front attachment, the wheels should also change sides for the tread profile to match the new travel direction. For this purpose, remove wheels and fit the right wheel onto the left side and the left wheel onto the right side.

Coupling and Decoupling Attachments

Proceed in same order as for rear attachments



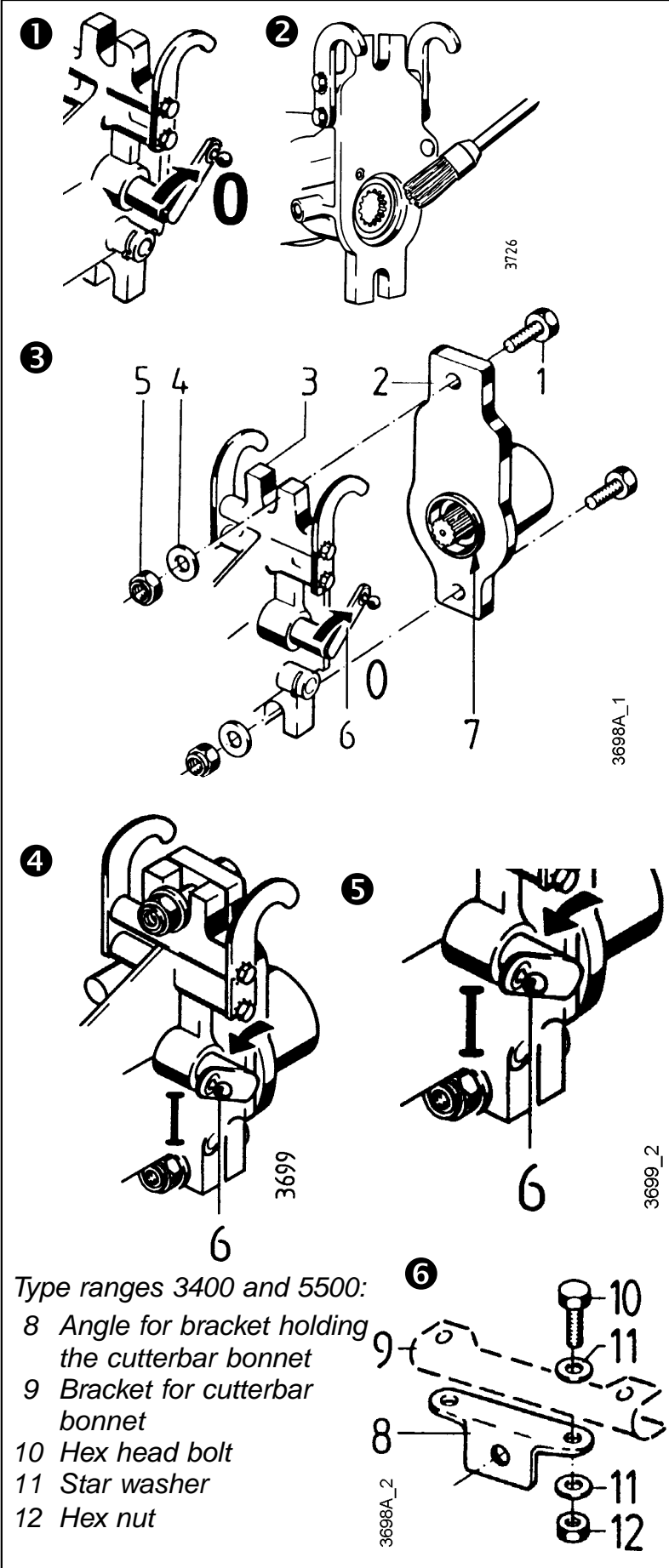

Type ranges 3400 and 5500:

- 8 Angle for bracket holding the cutterbar bonnet
- 9 Bracket for cutterbar bonnet
- 10 Hex head bolt
- 11 Star washer
- 12 Hex nut

Adapter for coupling agria attachments – type ranges 3400 and 5500

Coupling the Adapter

- Ensure that the coupling surfaces on the adapter and on the attachment are clean. Clean them, if necessary.

1 On PTO-driven attachment: Move lever (6) on the attachment to position "0".

2 Ensure some bio-lubricating grease is applied to the coupling sleeve.

3 Inch the adapter (2) towards the attachment (3). Ensure that the flange centerings (7) are in the correct position and that flange surfaces are flush.

4 Attach attachment bolts (1, 4 and 5) and tighten them.

5 On PTO-driven attachments move lever (6) on the attachment to position "I". The PTO is then engaged by actuating the PTO-shifter on the basic machine.

6 To attach the cutterbar type ranges 3400 and 5500, attach the bracket for the cutterbar bonnet (8–12) to the top attachment bolt.

- **Decoupling** in reverse order.



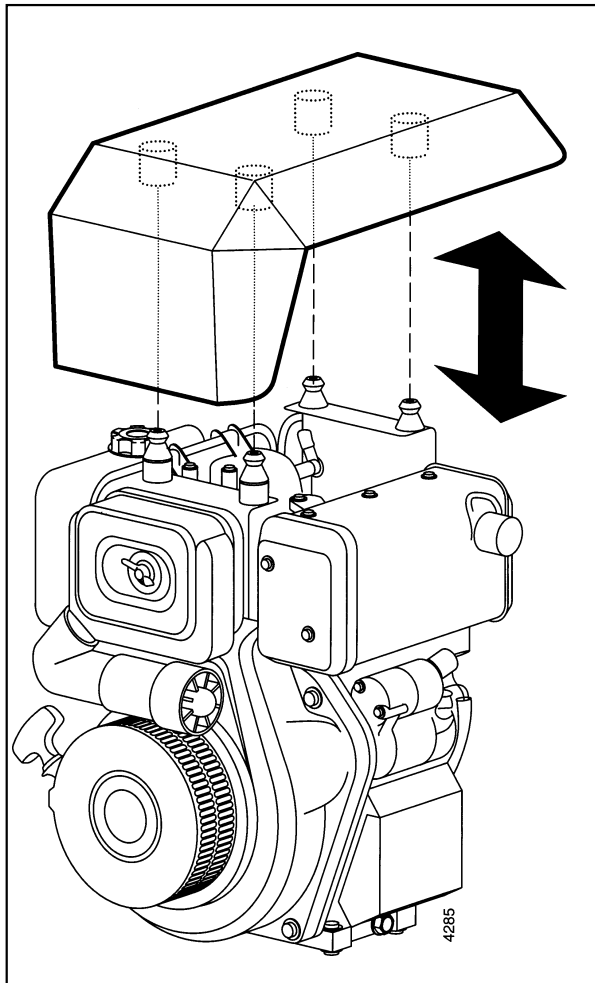

Engine cover

Removing the engine cover

- Pull on the cover at its rear end and lift it
- Pull on the cover at its front end and remove it

Replacing the engine cover

- Place the rubber cups onto the ball-heads
- Then press gently on the front and rear cover ends to lock the cups onto the ball-heads.

i For an easier assembly, apply Bio-lubrication grease on the rubber cups.

Commissioning

Please note that durability and operational safety of the engine depend to a large extent on its breaking-in. Always allow a cold engine to warm up for some minutes and never run it at full throttle at the beginning.

Please note: for the first **20** hours of operation (break-in period) do not use the engine at full power.

Make sure you check and maintain air filters regularly and use clean fuel. Only use branded petrol.

Only use fresh, clean fuel (not older than 3 months) and approved fuel cans to be purchased in special shops. Rusty sheet metal cans or fuel cans not suited for petrol are not permitted.

For the first commissioning or after longer periods of no operation, fill fuel tank to maximum to avoid starting problems.



Be careful when dealing with fuel.



Fuel is easily inflammable and explosive in certain conditions!



- Do not refill in closed rooms.
- Before each fuel fill, shut off the engine and wait until it has cooled off.
- Never refill close to open fire, inflammable sparks or hot engine parts.
- Do not smoke during filling!
- Do not spill any fuel, use a proper filling device.

Do not cause fuel tank to overflow, but leave a 5 mm margin for the fuel to expand.

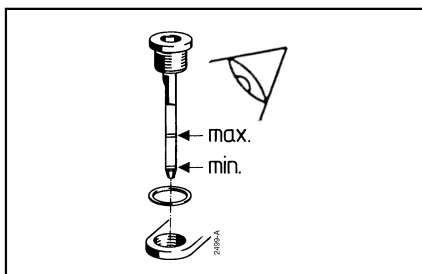

- Check transmission oil level (see page 54).

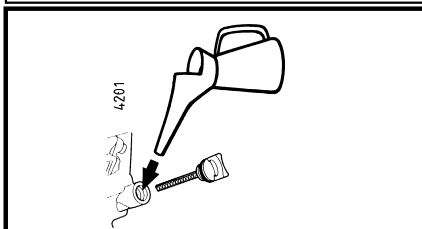

Note: For reasons of transport, the engine is not filled completely with engine oil!

Before you operate the engine the first time, fill in engine oil (see page 45)!

4

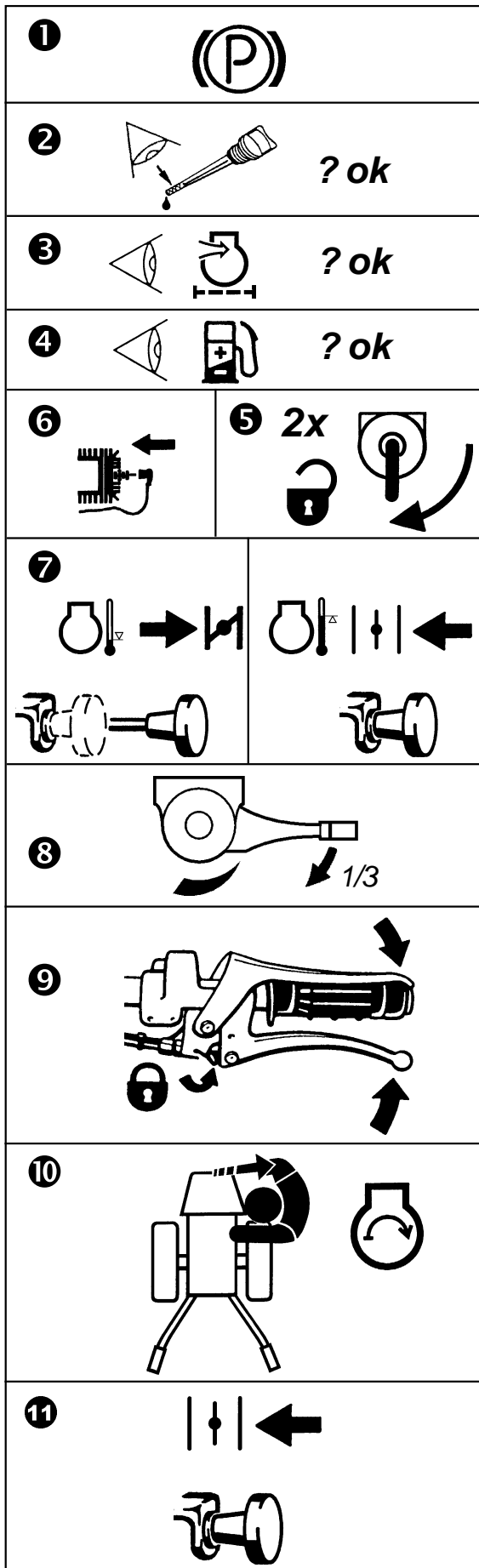

Starting Petrol Engine

⚠ Never start engine in closed rooms. Exhaust fumes contain carbon monoxide, which acts toxic when inhaled.

- 1 Pull the central brake (B/10 und 11).
- 2 Check the engine oil level.
- 3 Air filter cleanful?
- 4 Sufficient fuel is filled into the tank?
- 5 Mount spark plug connector.
- 6 Open fuel tap (E/15).
- 7 Choke
 - **Cold engine:** pull CHOKE knob (E/13)
 - **Warm engine:** leave CHOKE knob in normal operating position or pull out half way.
- 8 Set speed control lever (B/8) to 1/3 throttle.
- 9 Press safety circuit lever and hand clutch lever in start position.
- 10 Start engine from a position outside the danger zone.

Pull starting-rope on handle (E/10) until you feel starter clutch engage. Then **pull hard and fast** to start the engine. After the start, carefully let rope glide back. Do not let snap.
- 11 Once the engine has started, let it warm up for some time. Slowly push choke back into operating position, if necessary.

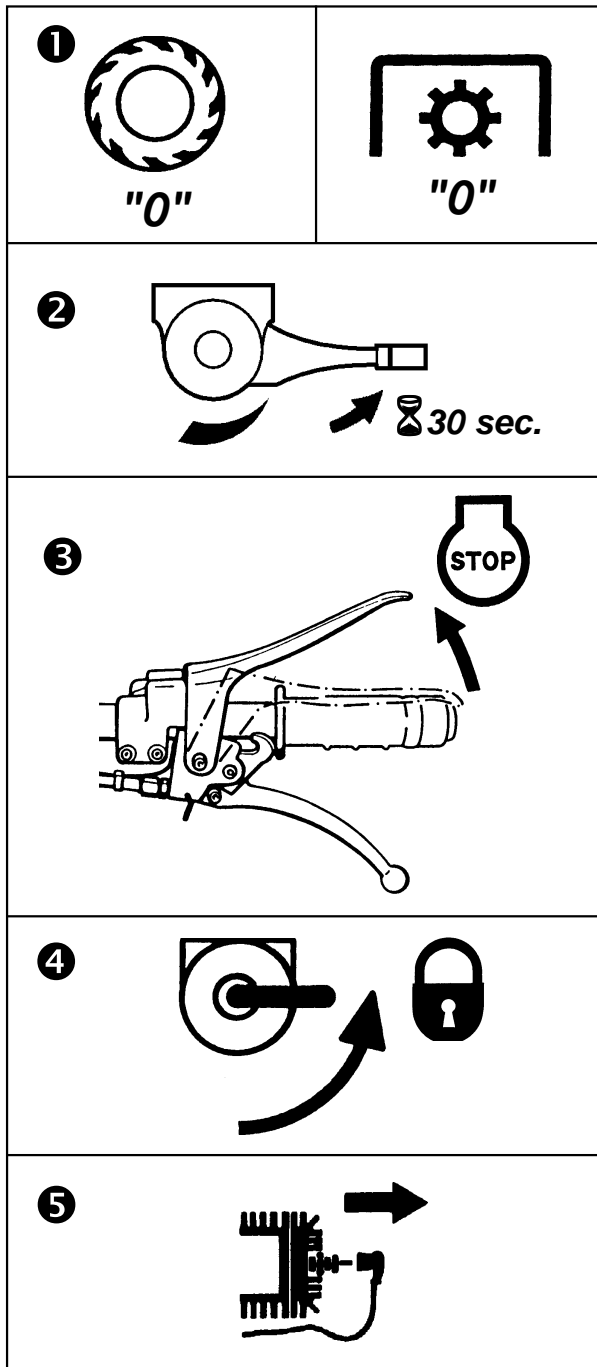

Switching off Petrol Engine

➊ Move the gear shifter and PTO speed shifter to position "0".

➋ Move the speed control lever to idle position and let the engine run idle for approx. half a minute.

➌ Release safety lever (B/1).

➍ Close the fuel tap.

➎ Secure the two-wheel tractor against rolling away and unauthorized use – disconnect spark-plug connector.

i **Note:** Engine-off-switch (B/1) also serves as **emergency off-switch**. If necessary, set switch to "0" to turn engine off.

i To park the machine for longer periods of no operation, do not use the engine-off-switch to turn off the engine, but close fuel taps and let engine run until it slowly comes to a complete stop. This ensures the carburetor to be empty and no resin residue to deposit.

4

4. Commissioning and Operation

Diesel Engine Version

agri^a

Commissioning

Please note that durability and operational safety of the engine depend to a large extent on its breaking-in. Always allow a cold engine to warm up for some minutes and never run it at full throttle at the beginning.

Please note: for the first **20** hours of operation (break-in period) do not use the engine at full power.

i **Make sure you check and maintain air filters regularly and use clean fuel. Only use branded Diesel, ensure timely provision of “winter Diesel fuel” (see page 9).**

Only use approved fuel cans to be purchased in special shops. Rusty sheet metal cans or fuel cans not suited for Diesel are not permitted.

For the first commissioning or after longer periods of no operation, fill fuel tank to maximum to avoid starting problems.

Be careful when dealing with  fuel.

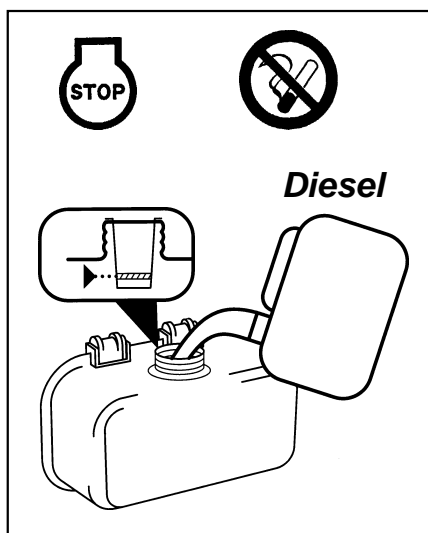

- Do not refill in closed rooms.
- Before each fuel fill, shut off the engine and wait until it has cooled off.
- Never refill close to open fire, inflammable sparks or hot engine parts.
- Do not smoke during filling!
- Do not spill any fuel, use a proper filling device.

Do not fill the fuel tank beyond the red mark on the filler strainer.

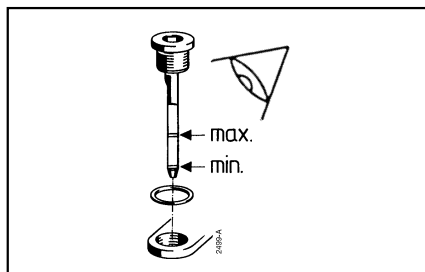

- Check transmission oil level (see page 54)

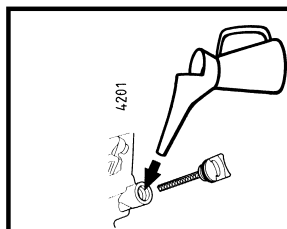

i **Note:** For reasons of transport, the engine is not filled completely with engine oil!

Before you operate the engine the first time, fill in engine oil (see page 50)!

1	
2	? ok
3	? ok
4	? ok
5	
6	
7	
8	
9	
10	
11	

Starting Diesel Engine

⚠ *Never start engine in closed rooms. Exhaust fumes contain carbon monoxide, which acts toxic when inhaled.*

1 Engage the central brake (B/10 and 11) to improve tractor stability.

2 Check the engine oil level.

3 Air filter cleanful?

4 Sufficient fuel is filled into the tank?

5 Open the fuel tap (D/3).

6 Set speed control lever (B/8) to "max."

7 Set safety lever (B/1) and hand clutch lever (B/2) to start position.

8 Slowly pull on the handle of the starting-rope (D/6) until you feel resistance (piston in compression position).

9 Pull decompression rope (D/14) downwards.

10 Start engine from a position outside the danger zone.

Pull starting-rope (D/6) hard and fast to start the engine. After the start, carefully let rope glide back. Do not let snap.

- Decompression automatically goes back into former position.

11 Slowly set speed control lever to centre position (half throttle) and let engine warm up for some time.

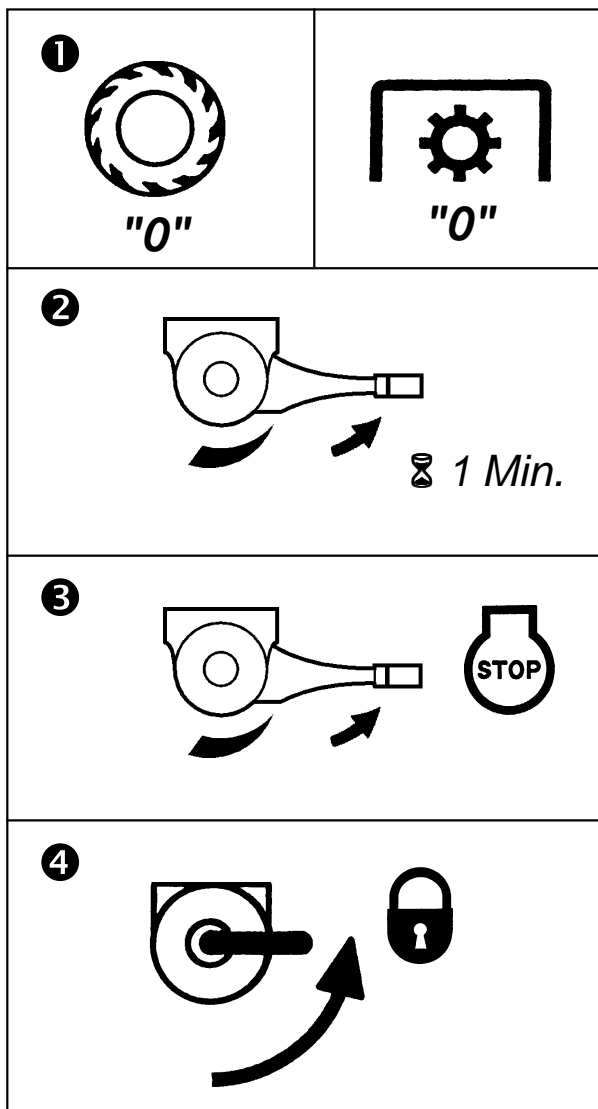

Turning off Diesel Engine

➊ Set gearshift and PTO speed change shift to position "0".

➋ Before you turn off the engine let it run at increased idling speed for 1 minute to cool down and to avoid carbon to deposit on the injection valve. This ensures continued and reliable operation.

➌ Set speed control lever (B/8) to "STOP".

ⓘ For turning off the engine never activate decompression, as this might damage the valves.

➍ Close the fuel tap (D/3).

⚠️ **Secure two-wheel tractor against rolling away and unauthorized use.**

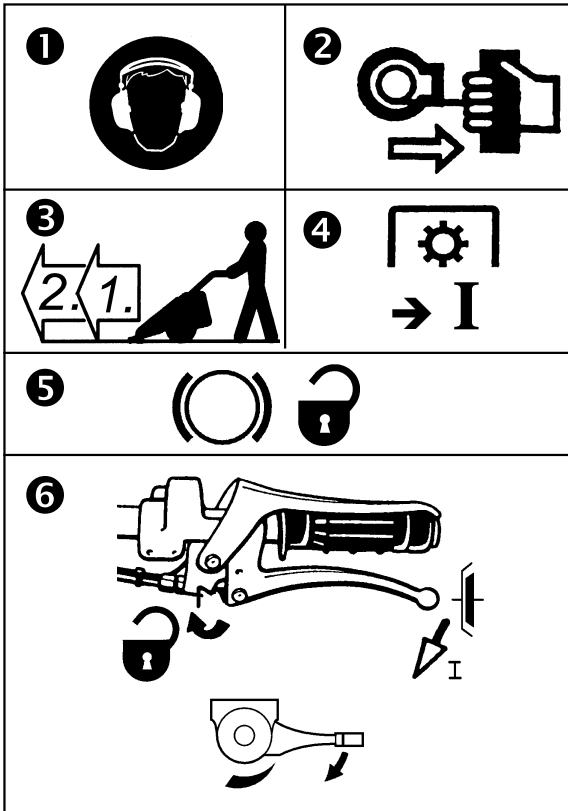

Operations

Check safety circuit function
- Only operate the machine if safety circuit works!

- ❶ Wear individual protective ear plugs and solid shoes.
- ❷ Start the engine as specified in chapter "Starting the Engine".
- ❸ Engage appropriate gear.
- ❹ For operations with PTO-powered attachments: switch on the attachment drive.
- ❺ If required release the brake.
- ❻ Slowly release the hand clutch lever while pressing the throttle.

4

Direction change from forward to reverse:

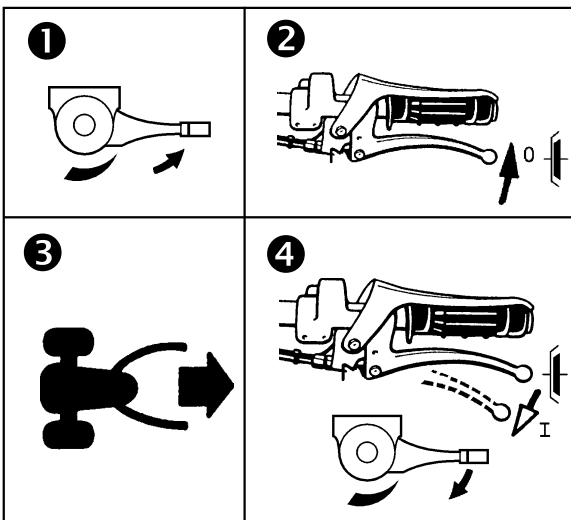

- ❶ Set speed control lever to idling position.
- ❷ Pull hand clutch lever and hold.
- ❸ Move F/R drive to position reverse.
- ❹ Slowly release hand clutch lever while pressing the throttle.

Proceed vice versa for direction change from reverse to forward.

Note for Mowing

After mowing or in case of jams:

- Move gear shifter to idle position. The machine comes to a stop but not the knives, thus freeing the cutter bar from grass.
- Move the PTO speed shift lever to position "0".

Never leave two-wheel tractor unattended with the engine running.

If cleaning becomes necessary during operation, the engine must be switched off and the spark plug connector disconnected for safety reasons.

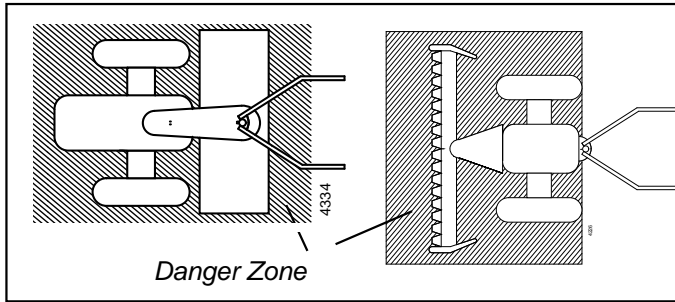

Danger Zone

⚠ Keep out of the machine's danger zone during starts and operation.

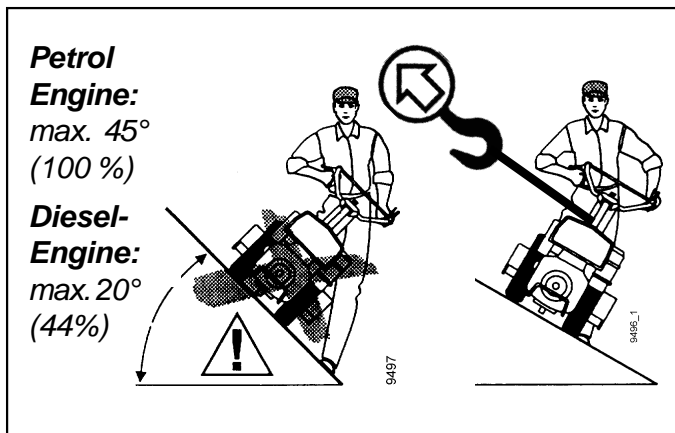

Mowing on Slopes

⚠ To prevent the tool carrier from sliding on slopes make sure it is secured by another person using a bar or a rope. This person must stay at a higher position than the vehicle and at a safe distance from the attachment at work.

4

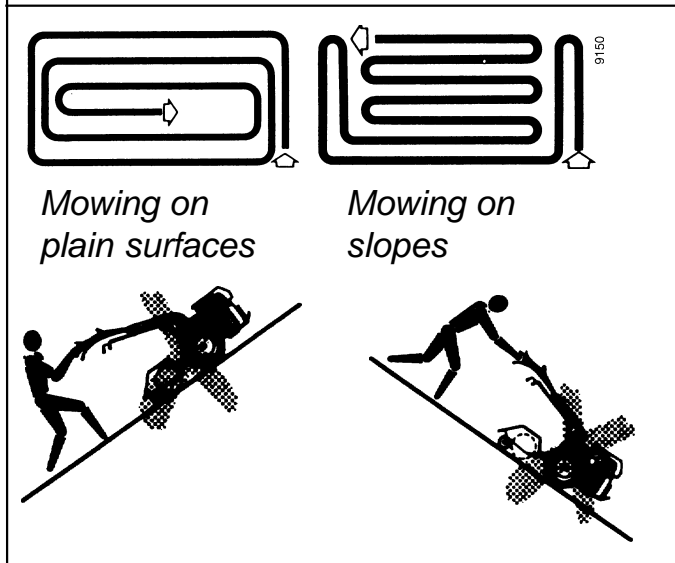

If possible, always work across the slope.

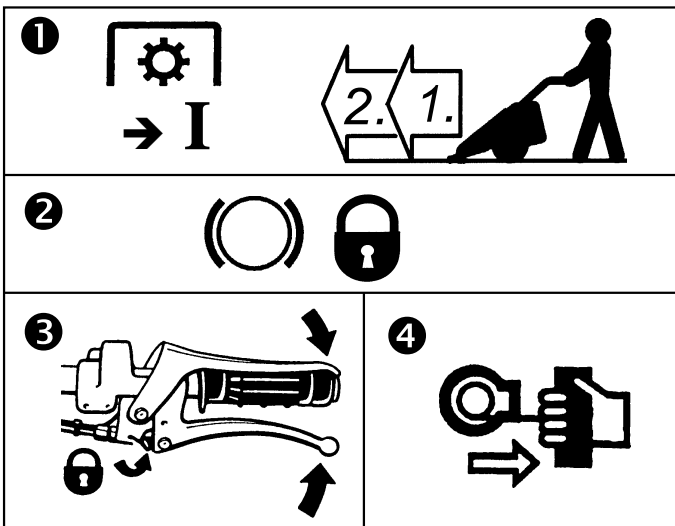

Starting the Engine on Slopes

- 1 Keep gears for attachment drive and travelling drive running; braking effect.
- 2 Engage central brake.
- 3 Move clutch lever and safety circuit lever to start position.
- 4 Re-start engine.



Apart from observing all operating instructions, it is also important to pay attention to the following maintenance instructions.

Please note:



Only do all maintenance work with the engine shut off and spark plug connector disconnected.



When working on mowing knives, wear safety gloves!

Engine

Check oil level

- **each time you take up operation and after 8 operating hours,**
- **only with engine switched off and tractor in horizontal position.**
- **Clean oil plug and surrounding parts.**
- **Remove oil plug, clean dip-stick with a clean cloth and dip back into oil tank (do not screw in), take out dip-stick and read oil level.**
- **In case oil level is below lower mark, refill engine oil (refer to “Specifications”) until oil level reaches rim of oil filler neck.**

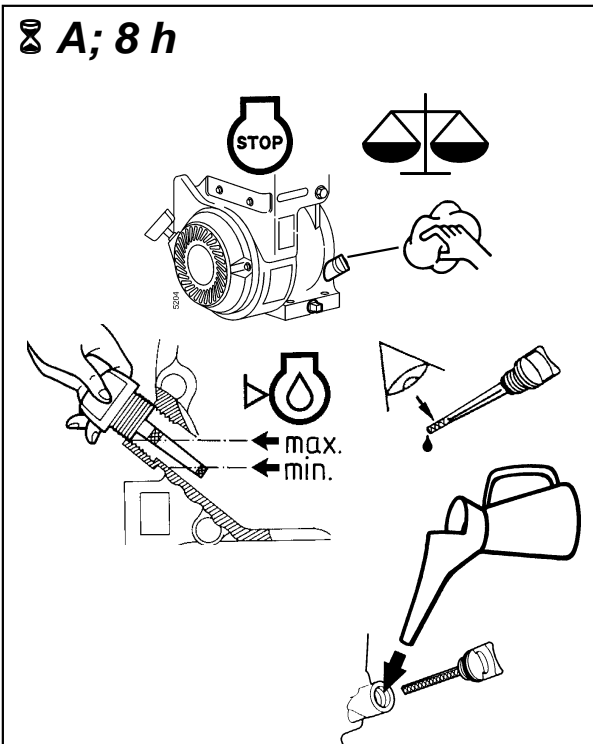

Changing Engine Oil

The first oil change is after 25 operating hours. Following oil changes are after every 50 operating hours. Change oil while engine is still warm, but not hot – danger of burns!

- **Clean drain plug (1) and surrounding parts.**
- **Change the oil and dispose of properly.**



Check sealing washer for good condition and exchange, if necessary!

- For engine oil quality refer to “Specifications”

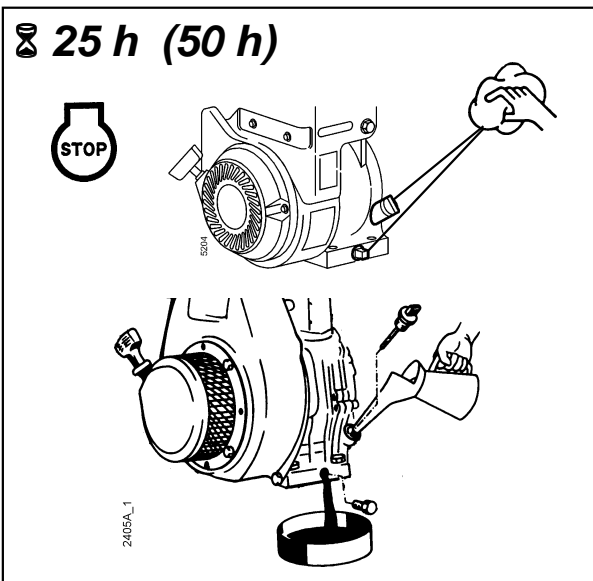

5

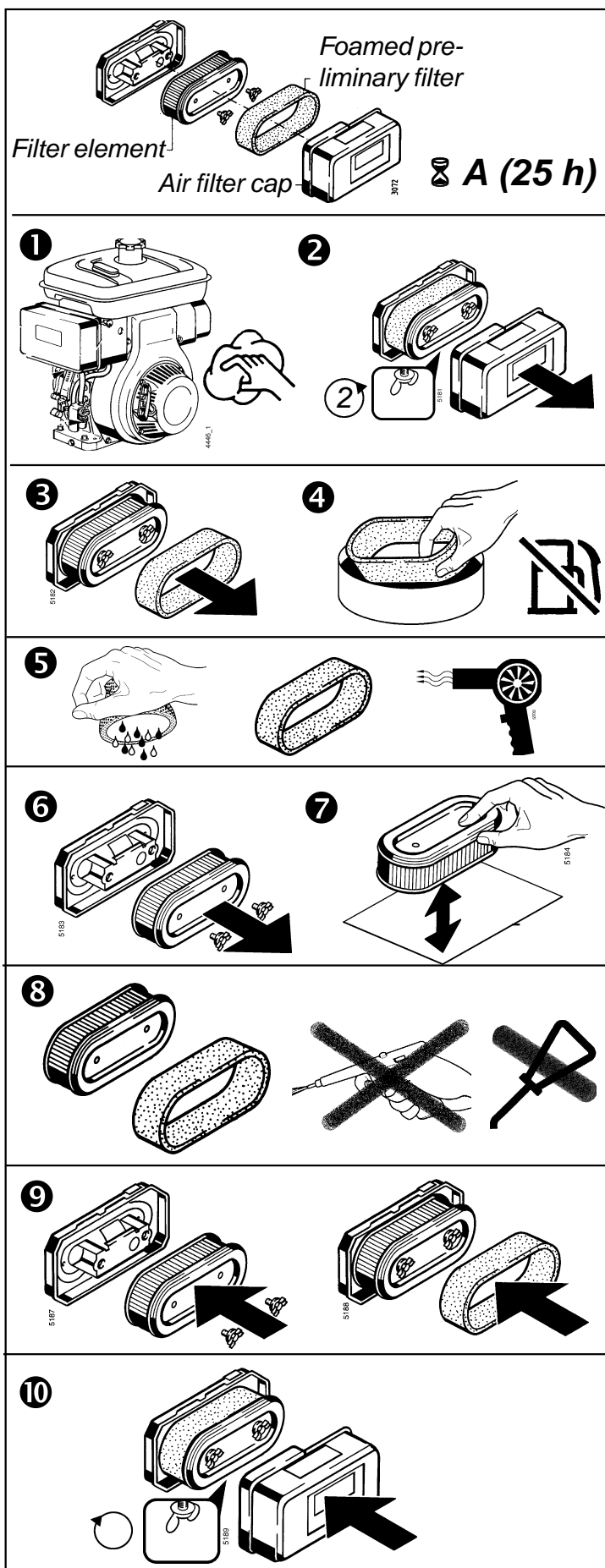

Dry-Type Air Filter

When you take up operation check the air filter (E/12) on dirt, clean it if necessary.

Clean the air filter at least every **25** operating hours or at **3-month** intervals, after some hours in very dusty conditions:

1 Clean the air filter and surrounding parts.

2 Loosen the wing nut and take off the filter cap.

3 Carefully remove the foamed preliminary filter.

4 Wash the foamed preliminary filter in warm lye (do not use petrol).

5 Squeeze the foamed preliminary filter like a sponge and dry it.

6 Remove the filter element.

7 Tap the filter element against a smooth surface.

8 Do not clean the foamed preliminary filter and the filter element using compressed air and do not soak it in oil!

9 Reinstall the filter element and the foamed preliminary filter.

10 Reposition the filter cap and fasten the wing nut.

● Replace the filter element after **5 cleaning actions** or **approx. every 200** operating hours.

ⓘ Replace immediately damaged filter elements.

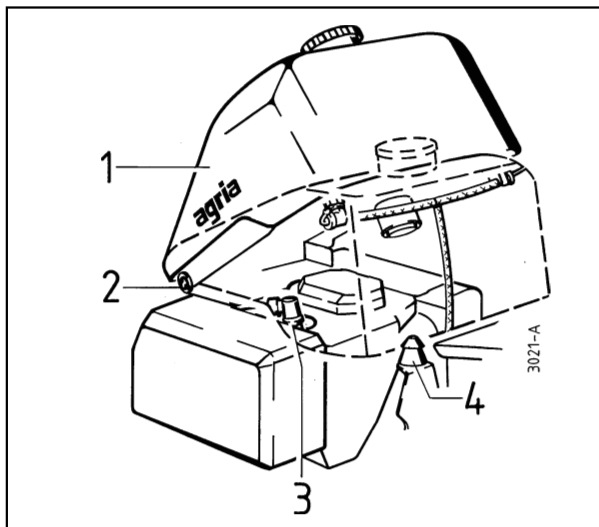

Cleaning the Spark Plug and Readjusting the Electrode Gap

The spark plug (3) is arranged underneath the fuel tank:

❶ Fold up fuel tank (1).

If fuel tank does not stay up in folded position, tighten hinge screws (2) slightly until fuel tank stays up and still folds easily up and down.

❷ Place back:

fold back fuel tank and lock onto ball button (4).

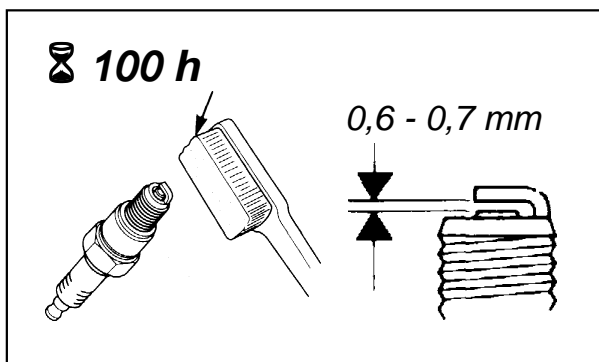

After every **100** operating hours or ignition problems:

- remove soot from spark plug electrodes with a steel brush,
- check spark plug gap and set to 0.6...0.7mm.

Exchange spark plugs after approx. **200** hours of operation.

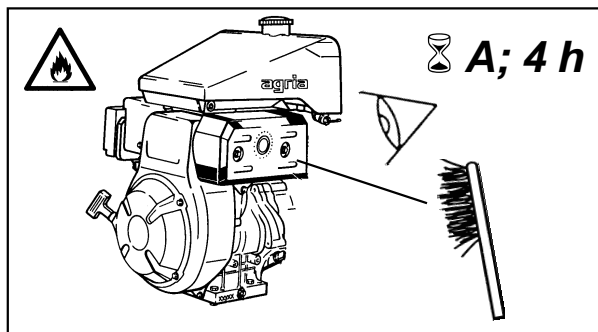
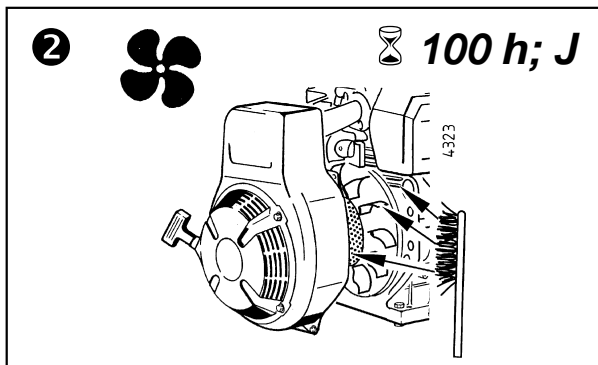
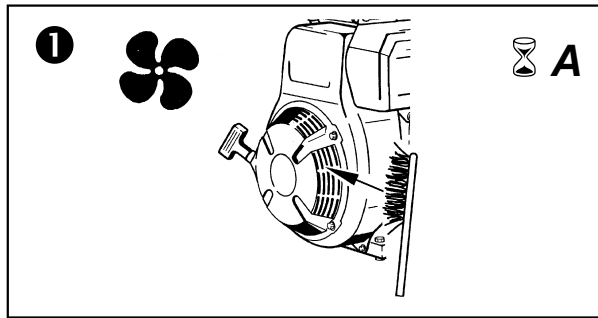

Cleaning the Cooling System

Clogging of plants and dust may occur in the cooling system. Operation with the cooling system clogged lets the engine heat up and causes damage.

① Always check cooling-air screen (E/7) and remove dirt and plants sucked in.

② Clean fan system at least **once per year**, preferably before the season starts. Take off fan case and clean cooling fins on both, cylinder and cylinder head, clean guiding plates and cooling-air screen, both serving for good air circulation. → **agria - Service** ←

Exhaust System

Check exhaust system (E/3) on a regular basis for plant trash and clean, if necessary. Otherwise

danger of fire results.

Check each time before you take up operation.

Fuel Hoses

Exchange fuel hoses every **2 years**. Leaking hoses must be exchanged immediately.

Cleaning the Fuel Strainer

Check the strainer on the fuel tap (E/15) at least **once a year** for water and other impurities.

- Close the fuel tap.
- Remove the fuel strainer and remove the impurities, replace if damaged.
- Rinse the strainer container in fuel.
- Then screw it back on correctly, to avoid fuel leakage.

5

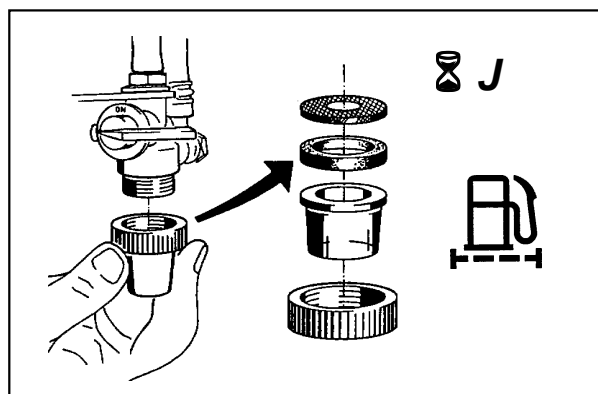

Cleaning Cylinder Head

After every **400** hours of operation take off cylinder head and remove carbon deposits on cylinder, cylinder head, piston crown and valves with a steel brush. Afterwards, clean with soft brush. Renew head gasket and reassemble to cylinder head. Tighten cylinder head bolts in turn. Tighten with a torque of **26 Nm**.
→agria - Service←

Re-adjusting Valve Lash

After every **400** hours of operation, re-adjust valve lash. Intake and outlet valve are at 0.1mm when the engine is cold.
→agria - Service←

Cleaning the carburetor

Clean the carburetor every **400** operation hours and then readjust the idle speed.

Idling Speed

Always ensure that idling engine speed is adjusted correctly.

Ensure smooth running of engine by positioning speed control lever to idling position at stop.

To set engine speed, adjust idling speed control screw (2) and idling speed mix control screw (1) in turn. Then adjust throttle control cable to no play with adjusting or locking screw. Do this while the engine is warm. (For idling speed rates refer to "Specifications").

→agria - Service←

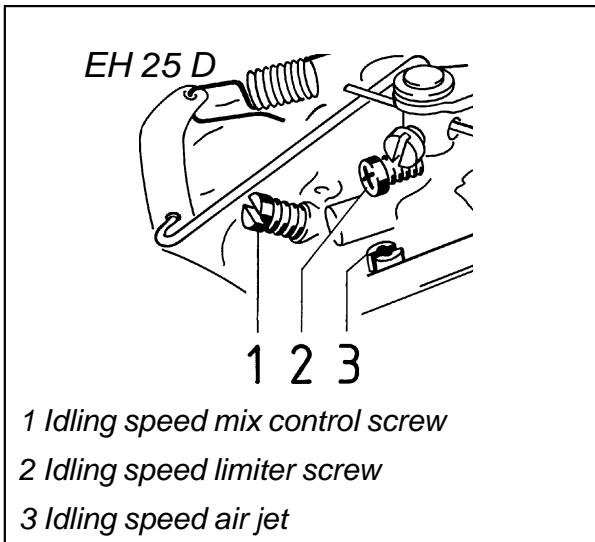

Idling Speed Governor

For correct functioning of the governor on the engine and for adjustment of upper idle speed ranges the governor spring must be in the appropriate place, see fig.

⚠ Any changes to the position of the spring cause warranty and type approval to become void.

Keep governor spring, speed control lever and linkages free from dirt and plant trash at all times.

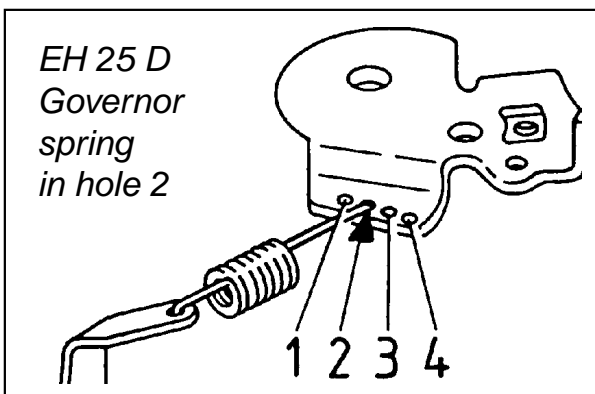

i Apart from observing all operating instructions, it is also important to pay attention to the following maintenance instructions. Please note:

! Only do all maintenance work with the engine shut off and spark plug connector disconnected.

g When working on mowing knives, wear safety gloves!

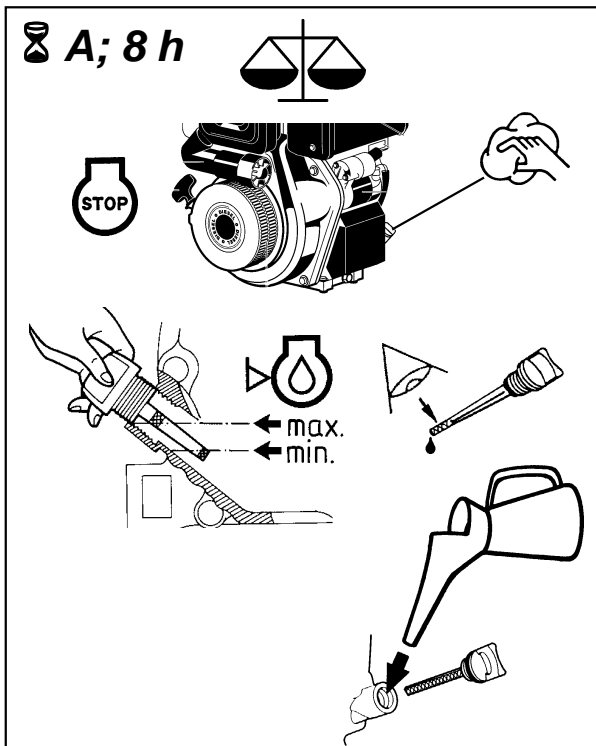

Engine

Checking Oil Level

- Each time you take up operation and after every 8 operating hours.
- Check only with engine switched off and machine in horizontal position.
- Clean oil dip stick and surrounding parts.
- Unscrew the oil dip stick, clean the dip-stick with a clean rag, re-insert it all the way and screw it in.
- Unscrew the oil dip stick and read the oil level.
- Refill oil, if the oil level is below the lower dip-stick mark. Refill engine oil (see "Specifications") up to upper level mark on dip-stick; do not overfill!

5

8 (50 h) 200 h

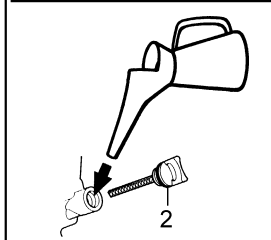
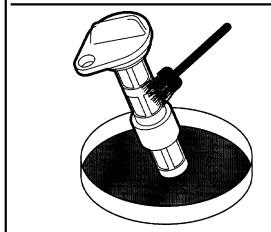
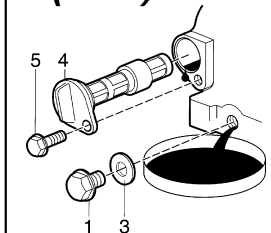

Changing Engine Oil

The first oil change is **after 50 operating hours**. Subsequent oil changes are after **200 operating hours** or **once a year**, depending on which period is completed first. At extreme strain and high temperatures, change oil after **100 operating hours** while the engine is still warm, but not hot – **danger of burns!**

- Clean oil filler plug, drain plug and surrounding parts.
- Open the filling plug and the drain plug and drain the oil into a suitable container and dispose of properly!
- Each time you change engine oil, wash engine oil filter in Diesel fuel. Replace damaged filter.
- Fill fresh engine oil into the oil filling opening.

i Check sealing washer for good condition and exchange, if necessary!

Refer to Specifications for oil quantity and quality. Use a funnel or a similar device to fill the oil reservoir.

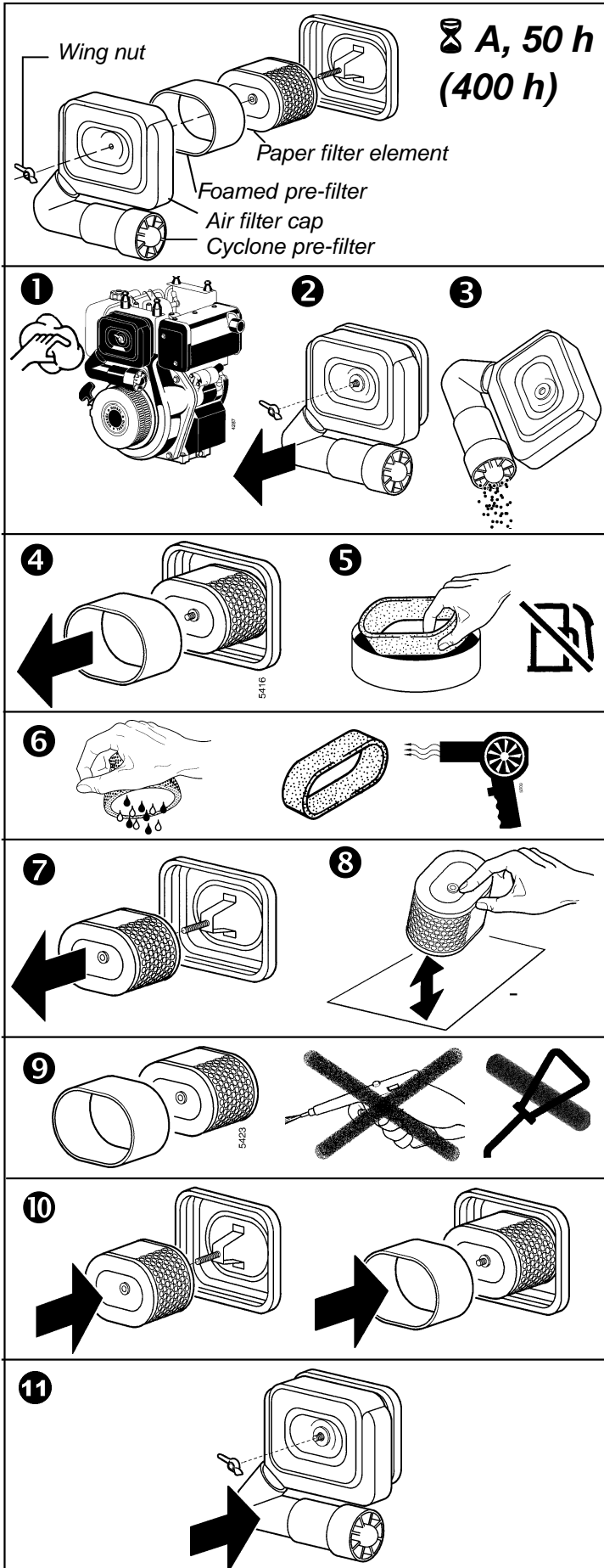

Dry-Type Air Filter

When you take up operation check the air filter (D/4) on dirt, clean it if necessary.

Clean air filter after a maximum of every **50** operating hours or at least after **3 months**, in case of heavy dust occurrence even earlier.

① Clean air filter and outside surrounding parts.

② Remove the wing nut and air filter cap including the cyclone pre-filter.

③ Rotate the air filter cap to allow any dirt inside the cyclone pre-filter drop out.

④ Carefully remove foamed pre-filter.

⑤ Wash foamed pre-filter in detergent and water (no petrol).

⑥ Squeeze foamed pre-filter and dry it.

⑦ Remove paper filter element

⑧ Slightly tap the element on a smooth surface.

⑨ Do not use compressed air to blow out dust of foamed pre-filter and paper filter element. Do not treat with oil.

⑩ Re-insert the filter element and attach the foamed pre-filter.

⑪ Reposition air filter cap and fasten with wing nut.

Replace paper filter element after every **400** operating hours or at least **once a year**.

ⓘ Replace immediately damaged filter elements.

5

Draining fuel

- Provide a proper container with funnel or similar.
- Remove the drain plug (16) and drain the fuel into a proper container.
- Re-attach the drain plug (16) with O-ring and tighten it (check the O-ring and replace it if necessary)

Fuel filter

Clean the fuel filter insert at approx. **200** operating hour intervals, earlier, if engine output drops.

Filter disassembly/assembly:

- Drain the fuel.
- Remove hex head nuts (X/7)
- Remove the filter insert (X/4) from the fuel tank through the filling hole.
- Clean the fuel filter with diesel oil and replace the insert if it is damaged.
- Reverse the above order to reassemble the fuel filter after checking and replacing (if necessary) the gasket (X/5) and o-ring (X/6).
- Tighten the hex nuts.
- Fill fuel and check the fuel system for leakages.
- Bleed the fuel system.
- Exchange the fuel filter after **400** hours.

Fuel Hoses

Exchange after every **2 years**; exchange leaking fuel hoses immediately.

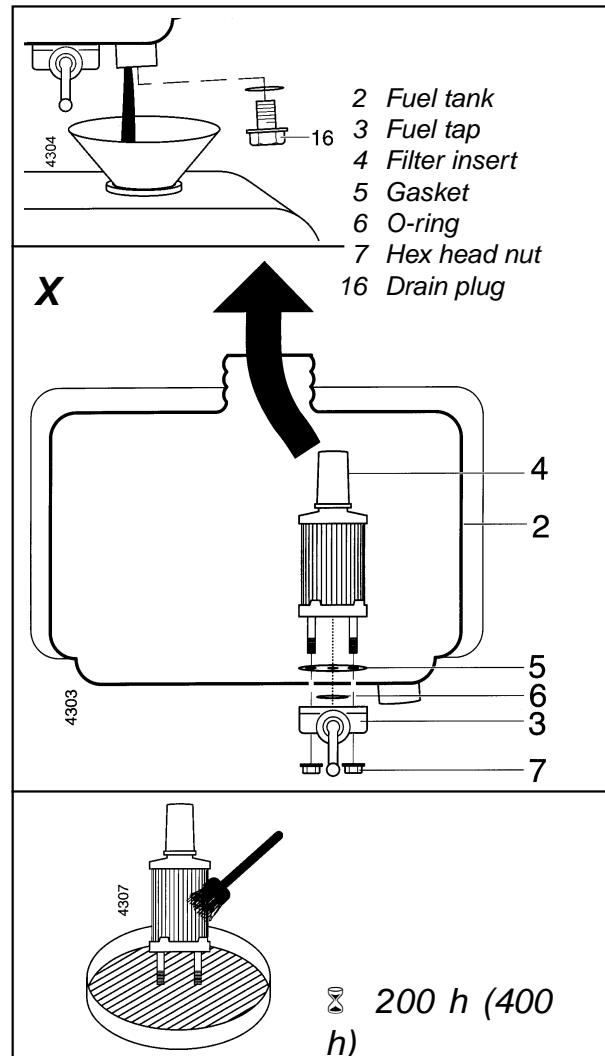

Bleeding the Fuel System

The engine is equipped with an automatic bleeding system, however after the fuel tank was emptied completely or after exchanging or cleaning the fuel-filter/fuel hoses proceed as follows:

- Fill diesel fuel into fuel tank.
- Crank engine several times with recoil starter or electric starter and start engine.
- Let engine run for approx. 1 minute.

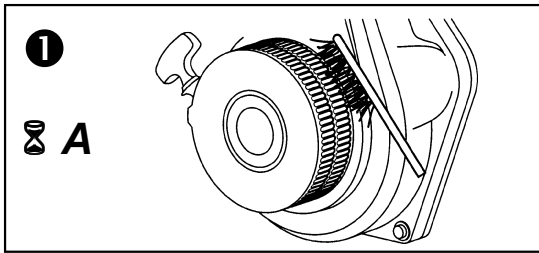

Cleaning the Cooling System

After a long period of operation the cooling system may become clogged by dirt and plant trash. Uninterrupted operation with a clogged cooling system causes the engine to heat up and become damaged.

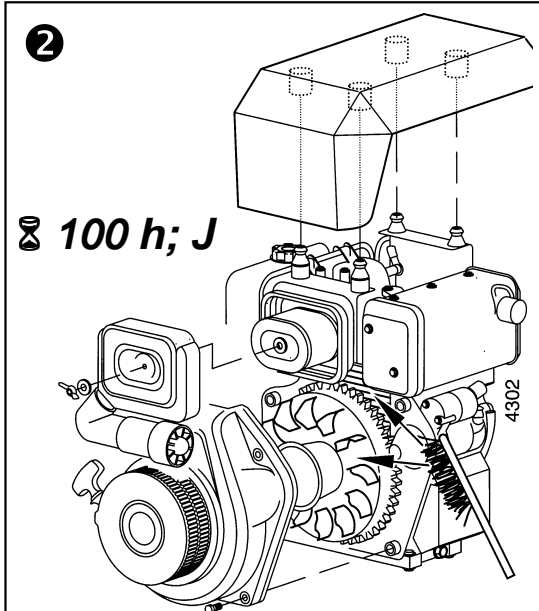

- Always check cooling-air screen (J/10) and free from dirt and plant trash taken in.

- After every **100** operating hours or at least **once a year** before season starts remove fan case to clean cooling fins on cylinder and cylinder head as well as guiding plates and cooling-air screen, both serving for smooth air circulation.

→agri^a - Service←

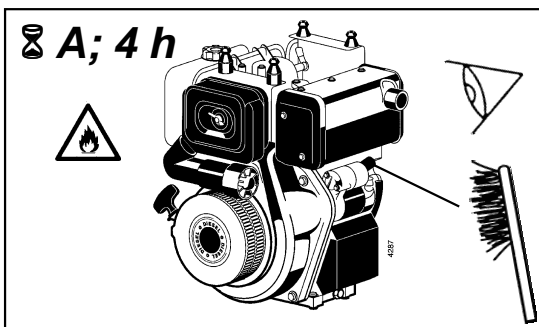

Exhaust System

Constantly check exhaust system (J/9) for plant trash and clean, if necessary. Otherwise **danger of fire!**

Re-adjusting Valve Lash

After every **400** operating hours re-adjust valve lash. Re-adjust outlet and intake valve lash to be 0.15 ± 0.02 mm when the engine is cold.

→agri^a - Service←

Injection Jet

After every **400** operating hours, clean and check injection jet.

→agri^a - Service←

Idling Speed

Always ensure that idling engine speed is adjusted correctly. At low speeds, the engine is supposed to run smoothly, with speed control lever at stop in neutral.

→agri^a - Service←

Machine

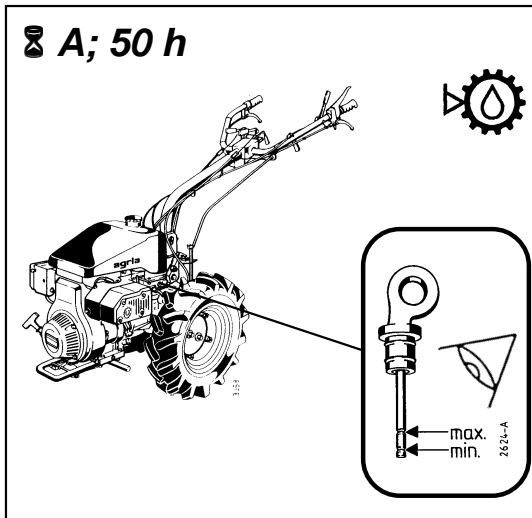

Gearbox: Base Machine

Check oil level in gearbox each time before you take the machine into operation and after every **50** operating hours (oil dip-stick and filling opening (A/3 or C/3). With the tractor parked in horizontal position, the oil level is between the notches “max” and “min”.

- Screw out oil dip-stick, clean with clean cloth and screw back in.
- Take dip-stick out again and read oil level, refill transmission oil, if necessary.

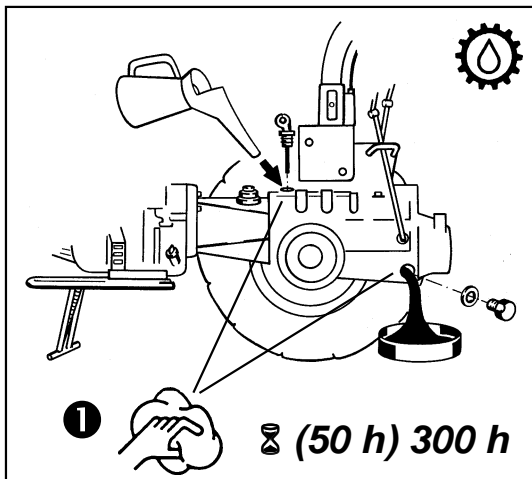

Change transmission oil of base machine after the first **50** operating hours and after every **300** operating hours while the engine is still warm.

- ①** Clean oil filler plug (A/3 or C/3) and drain plug (A//18 or C/18) as well as surrounding parts.
 - ②** Change the oil and dispose of properly.
- i** Check sealing washer for good condition and exchange, if necessary!

- For transmission oil quality refer to “Specifications”

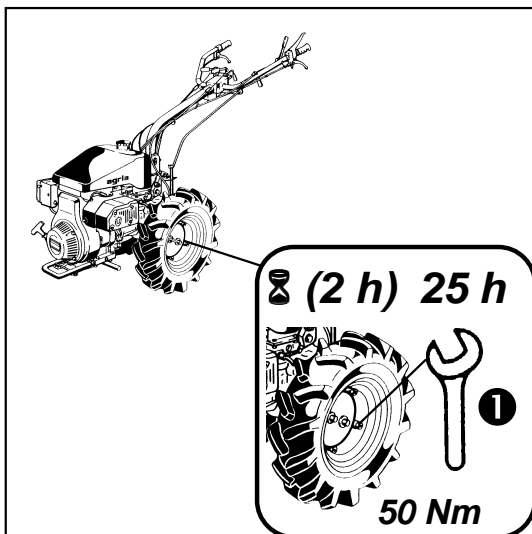

Drive-Wheels

① When commissioning the tractor and each time you change wheels, check and tighten wheel bolts and nuts after the first **2** operating hours with **50 Nm**. Proceed likewise when doing maintenance work.

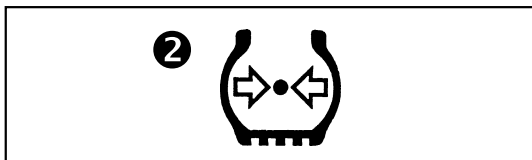

② Check tyre air pressure regularly. For smooth driving, make sure that there is the same pressure in front and rear tyres respectively. Drive-Wheels

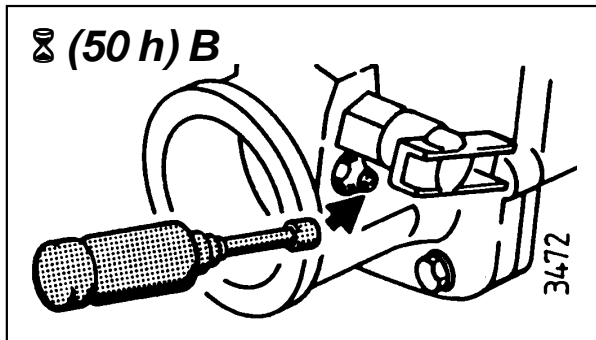

Coupling Attachments

After every **50** operating hours and each time you clean the machine with air-compressed water jets, lubricate the nipples with Bio-lubricating grease.

Additionally, grease the PTO each time before you couple an attachment.

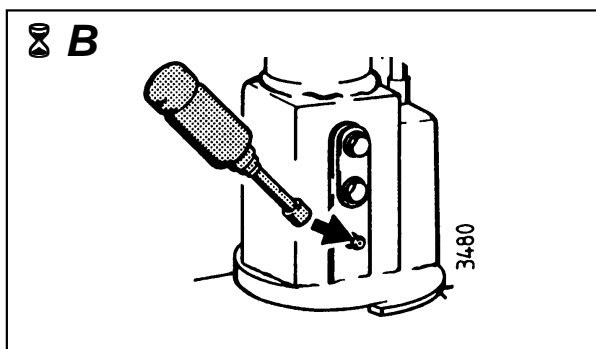

Steering Handle

- Lubricate nipples on steering handle and coupling Bio-lubricating grease yearly and after each cleaning with air-compressed water jets.

Apply grease generously to leave a grease collar around the bearings to prevent water and dirt from penetrating.

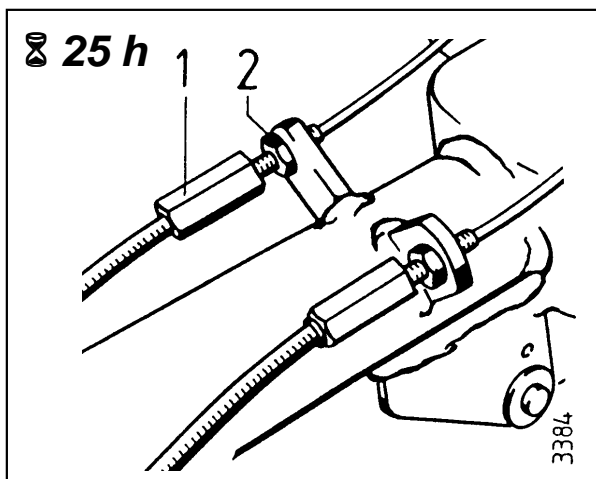

Single-Wheel Brake/Central Brake

Check the brake function each time you service and maintain the machine.

With the central brake engaged (brake levers are linked with a linch pin), both drive-wheels must decelerate evenly. To adjust the brake function, loosen locking nuts (2) on Bowden cables and adjust the cable setting nuts (1). After adjusting the cables, tighten locking nuts.

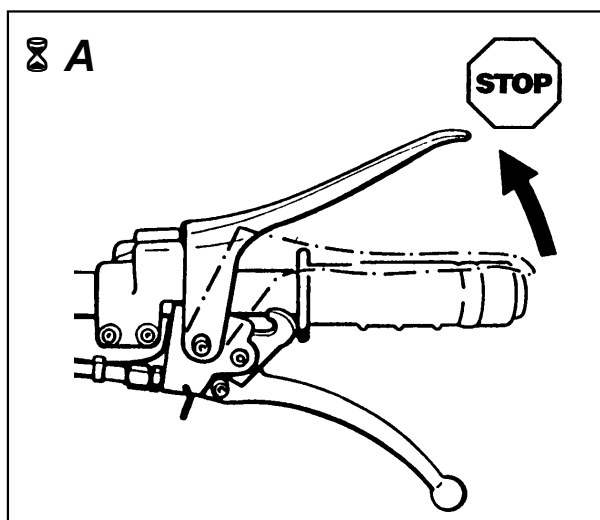

Safety circuit

Check safety circuit function each time you take up operation and each time you maintain the machine.

- At release of lever (B/1), the engine must automatically come to a stop.

- **Petrol engine:** Check electric lines and connections and exchange, if necessary.

→agri^a - Service←

- **Diesel engine:** If necessary, correct STOP-Bowden cable with Bowden cable set screw.

→agri^a - Service←

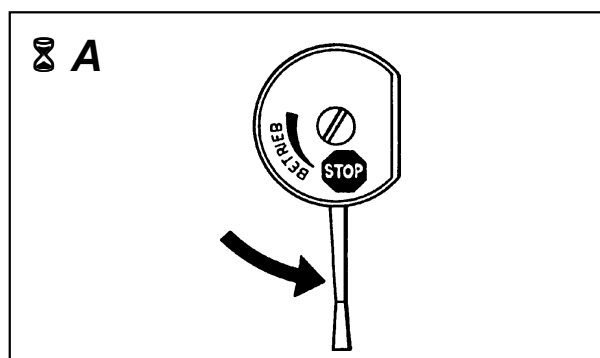

Engine Shut-off Switch

Check function of engine shut-off switch each time you do maintenance work.

- If the speed control lever is in "STOP" position, the engine must come to stop. If necessary, correct engine speed cable or STOP-Bowden cable on Bowden cable set screws.

→agri^a - Service←

5

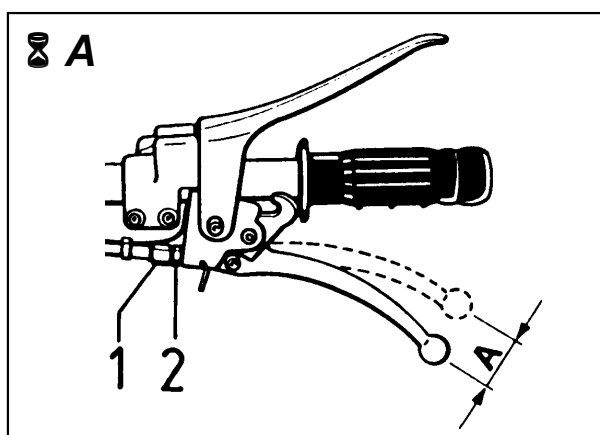

Adjustments on Hand Levers

Check clutch play or clutch adjustment each time you operate the machine. If necessary, re-adjust (especially after commissioning the machine, during break-in period, and after exchanging clutch linings).

- Remove locking nut (2) on the adjustment screw (1).

- Adjust the adjustment screw to a play of

A = 5–6 mm

- Re-tighten locking nut.

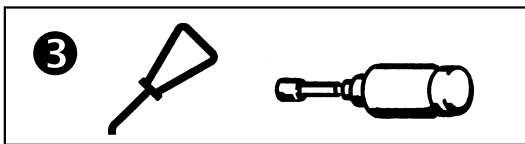
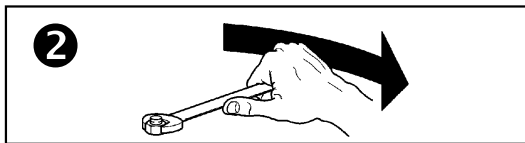
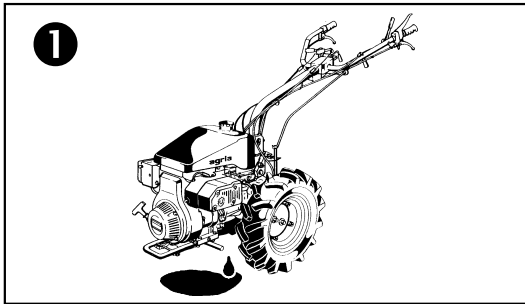

General Maintenance

- 1 Every time You take up operation watch out for fuel and oil leakage, repair if necessary.
- 2 Regularly check bolts and nuts for tight fit, re-tighten, if necessary.
- 3 At least **once a year** and after cleaning: Slightly grease all gliding and moving parts (e.g. speed control lever, lever bearing, etc.) with bio-lubricating grease and bio-lubrication oil.

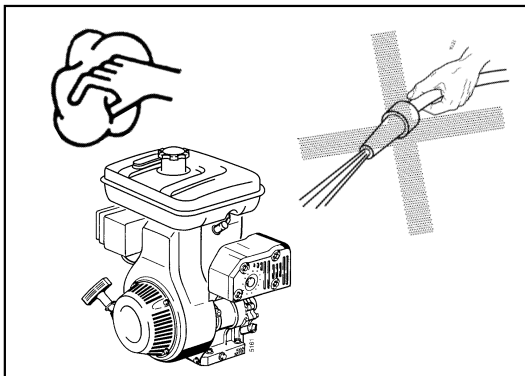

Cleaning

Engine

Clean engine only with a cloth. Avoid spraying with air-compressed water jets, as water might leak into ignition and fuel system causing malfunctions.

Machine

After each operation immediately clean the tilling tools and the protective hood. Therefore dismantle the protective hood.

Grease all gliding parts with Bio-ubricating grease and Bio-slushing oil.

After each cleaning with air-compressed water jets lubricate all lubrication points, oil and let two-wheel tractor run for a short time to press water out.

Apply grease generously to leave a grease ring around bearings to prevent water, plant sap, and dirt from penetrating.

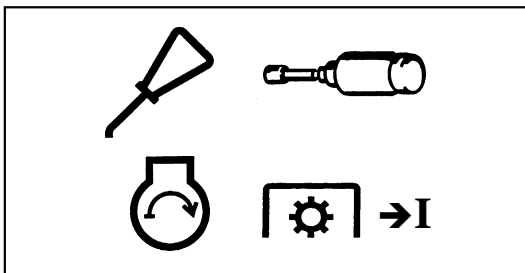
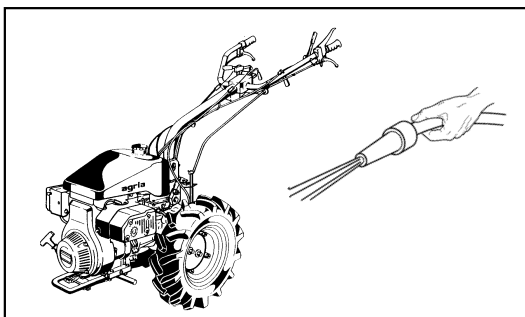

Storage

For longer periods of no operation prepare two-wheel tractor for storage. Proceed as follows:

a) Clean thoroughly

Repair paint coat.

b) Spray all shining parts and the cutter bar with Bio-slushing oil.

c) Engine preservation

● Petrol Engine

– Drain fuel completely or fill fuel tank and add fuel stabilizer (agria No. 799 09).
- **Observe enclosed instructions.**

Let engine run for approx. 1 minute.

– Change the engine oil.

– Fill a tea-spoon (approx. 0.03l) of engine oil into the spark plug opening. Slowly crank the engine.

– Set the piston to compression via the recoil starter (pull the starter grip until resistance is felt) – valves are closed.

– Slowly crank the engine after every 2–3 weeks (spark-plug connector is removed). Then set the piston to compression again.

● Diesel Engine

– Change engine oil.

– For longer storage, close exhaust pipe and air filter opening with crape or similar tape.

d) Drive-wheels

Support drive-wheels in such a way that tyres have no ground contact. Pneumatic tyres are quickly destroyed, if left standing under load and unsupported.

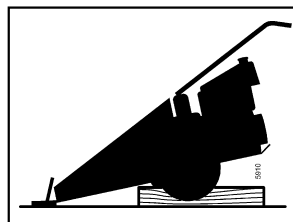

e) Clutch

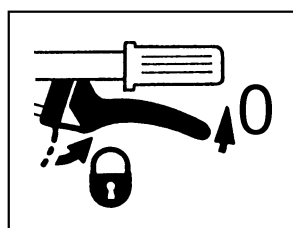

Always park two-wheel tractor with clutch lever pulled (pawl locked in place). Otherwise clutch problems

may result due to corrosion.

f) Parking

Because of severe corrosion **do not park the tractor**

- in humid rooms
- in rooms where fertilizer is stored
- in stables or adjacent rooms.

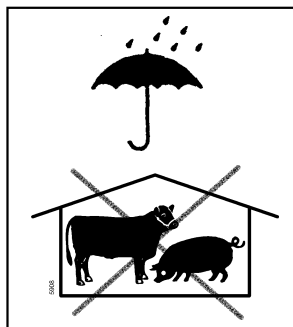

g) Covering the machine

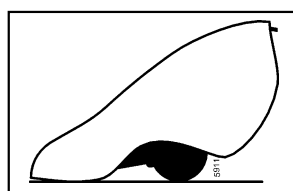

Protect the machine with cloth or a similar cover.

6. Troubleshooting



Observe safety instructions! Have all serious malfunctions on the machine or engine repaired by your agria workshop. They have the proper tools. Improper repairs can only add to the damage.

Problem	Possible cause	Remedy	Page
Petrol engine does not start	- Spark plug connector not connected	Connect spark plug connector	
	- Choke is not pulled	Set Choke-lever to operating position "BETRIEB"	38
	- Engine-off-switch is set to "0"	Set engine-off-switch to "I"	38
	- Safety circuit is not set to start position	Set safety circuit to start position	24
	- Fuel tank empty or poor fuel	Fill fresh fuel	
	- Fuel line clogged	Clean fuel line	47
	- Defective spark plug	Clean, adjust or exchange spark plug	47
	- Engine too much fuel ("flooded engine")	Dry and adjust spark plug and start at full throttle	47
	- Engine-off-line defective	Check line and connections	* 56
	- Inleaked air due to loose carburetor and suction line	Tighten fastening screws	
Misfirings in petrol engine	- Engine running in CHOKE range	Set CHOKE-lever to operating position	38
	- Loose ignition cable	Firmly connect spark plug connector to spark plug, fix ignition cable bracket	
	- Clogged fuel line or poor fuel	Clean fuel line, fill fresh fuel	*
	- Vent opening in fuel tank cap clogged	Exchange fuel tank cap	
	- Water or dirt in fuel system	Drain fuel and fill fresh fuel	
	- Air filter clogged	Clean air filter or exchange	46
	- Carburetor misadjusted	Re-adjust carburetor	* 49
Excessive temperature in petrol engine	- Low engine oil level	Refill oil immediately	45
	- Impaired cooling	Clean cooling fan grille, clean internal cooling fins	48
	- Air filter clogged	Clean air filter	46
	- Carburetor misadjusted	Re-adjust carburetor	* 49
Misfirings in petrol engine at high speeds	- Short firing intervals	Adjust spark plug	47
	- Incorrect idle mix	Adjust carburetor	* 49
Petrol engine frequently stalls in idle	- Firing interval too long, defective spark plug	Adjust or replace spark plug	47
	- Carburetor misadjusted	Re-adjust carburetor	* 49
	- Air filter clogged	Clean air filter	46

6. Troubleshooting

Problem	Possible cause	Remedy	Page
Petrol Engine does not run smoothly	- Speed control linkages clogged or jammed	Clean speed control linkages	48
Petrol Engine does not stop when set to stop	- Defective engine-stop-line, earth missing	Check line and connection, check earth contact	56
Petrol Engine output too low	- Air filter clogged - Loose cylinder head or damaged sealing - poor compression	Clean air filter Tighten cylinder head, exchange sealing Have engine checked	46 * *
Diesel Engine does not start	- Speed control lever set to "STOP" - Fuel tank empty or poor fuel - Fuel line or fuel filter clogged - Injector nozzle or injection line clogged - Wrong injection pressure	Move speed control lever to "Max" Fill fresh fuel Clean fuel line or filter Clean injector nozzle or injection line Check pressure	41 52 * 53 *
Misfirings in diesel engine	- Clogged fuel line or poor fuel - Vent opening in fuel tank cap clogged - Water or dirt in fuel system - Air filter clogged - Injector nozzle or injection line clogged	Clean fuel line, fill fresh fuel Exchange fuel tank cap Drain fuel and fill fresh fuel Clean air filter Clean injector nozzle or injection line	51 * 53
Excessive temperature in diesel engine	- Lack of engine oil - Impaired cooling	Refill engine oil immediately Clean fan grille, clean internal cooling fins	50 53
Diesel Engine misfirings at high speeds	- Injector nozzle clogged - Wrong injection pressure	Clean injector nozzle Re-adjust injection pressure	* 53
Diesel Engine frequently stalls in idle	- Air filter clogged	Clean air-filter	51
Diesel Engine does not stop when set to "STOP"	- Improper adjustment of engine-off-cable	Re-adjust engine-off-cable	56

6. Troubleshooting

Problem	Possible cause	Remedy	Page
Diesel Engine output too low	- Air filter clogged - Loose cylinder head or damaged gasket - Poor compression	Clean air filter Tighten cylinder head, exchange gasket Have engine checked	51 * *
Machine in general:			
Clutch does not decouple	- Hand clutch lever misadjusted	Adjust clutch free play	56
Clutch slips	- Hand clutch lever misadjusted - Worn out clutch	Adjust clutch free play Exchange clutch disc	56 *
Excessive vibration	- Loosened fastening screws	Tighten fastening screws	57

* = For this purpose contact your agria workshop.

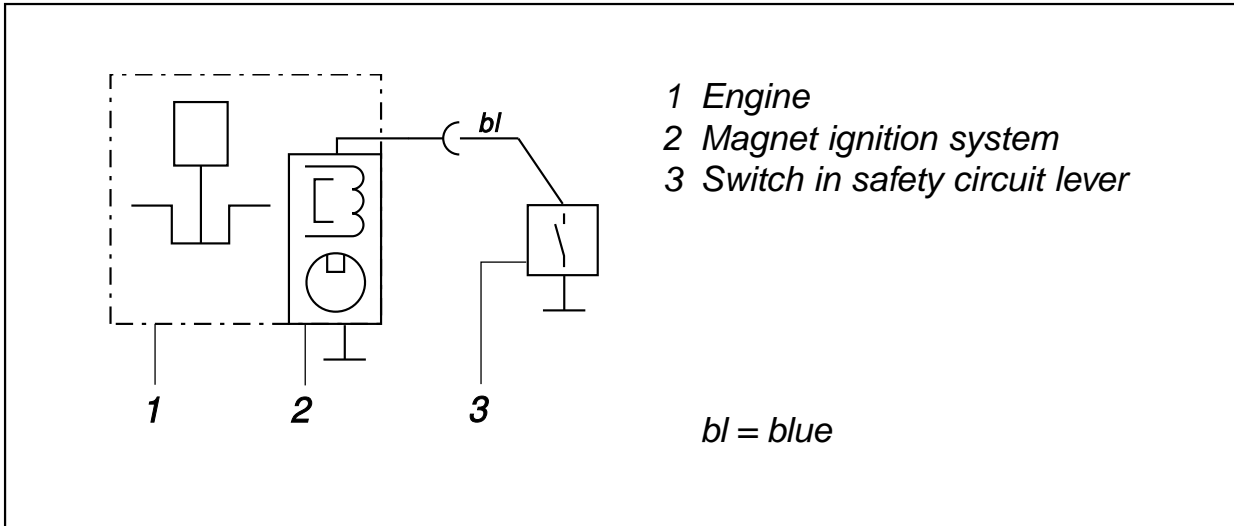

agri^a Order No.

Fuel Stabilizer for Petrol Engine

799 09	Fuel stabilizer	pouch	5 g
--------	-----------------	-------	-----

Varnishes

181 03	Spray varnish birch-green	spray tin	400ml
181 04	Spray varnish blood orange	spray tin	400ml
712 98	Spray varnish red, RAL 2002	spray tin	400ml
509 68	Spray varnish black	spray tin	400ml

Glues (for screw fastening), Surface Sealing

559 94	Glue (medium) LOCTITE 242	bottle	50ml
559 95	Glue (strong) LOCTITE 270	bottle	50ml
559 96	Glue (ultra strong) LOCTITE 638	bottle	50ml
509 85	Surface sealing (liquid) LOCTITE 573	tube	50ml
509 68	Surface sealing (liquid) LOCTITE 573	tube	250ml

Verschleißteile:

707 91	Air filter set, Robin engine
671 87	Spark plug, Bosch WR7AC
684 16	O-ring, oil dip-stick, Robin engine
009 05	O-ring 14x20x1.5, oil drain plug, Robin engine
415 060	Air filter element, Yanmar engine
415 010	Fuel filter, Yanmar engine
415 011	Fuel filter gasket, Yanmar engine
021 43	O-ring 14x1.6, Fuel tap, Yanmar engine
009 16	O-ring 16x22x1.5, oil drain plug, Yanmar engine
009 16	O-ring 16x22x1.5, oil dip-stick and oil drain plug, gearbox

Ersatzteillisten:

997 091	Base machine and Implements Type 3900
997 077	Robin Engines
997 147	Yanmar Engine
997 062	Cutter Bar

Figure D

Engine L100AE

- 1 Fuel tank cap
- 2 Fuel tank
- 3 Fuel tap
- 4 Air filter
- 5 Preliminary air filter
- 6 Starter grip
- 7 Cooling air grille
- 8 Decompression lever
- 9 Exhaust
- 10 -
- 11 Engine oil filler opening, dip-stick
- 12 Engine oil drain plug
- 13 Engine oil filter
- 14 Decompression cable
- 15 Injection pump
- 16 Fuel drain plug
- 17 Engine type plate; engine I.D.
- 18 Ball-head, engine cover

Fig. D
Engine L100AE

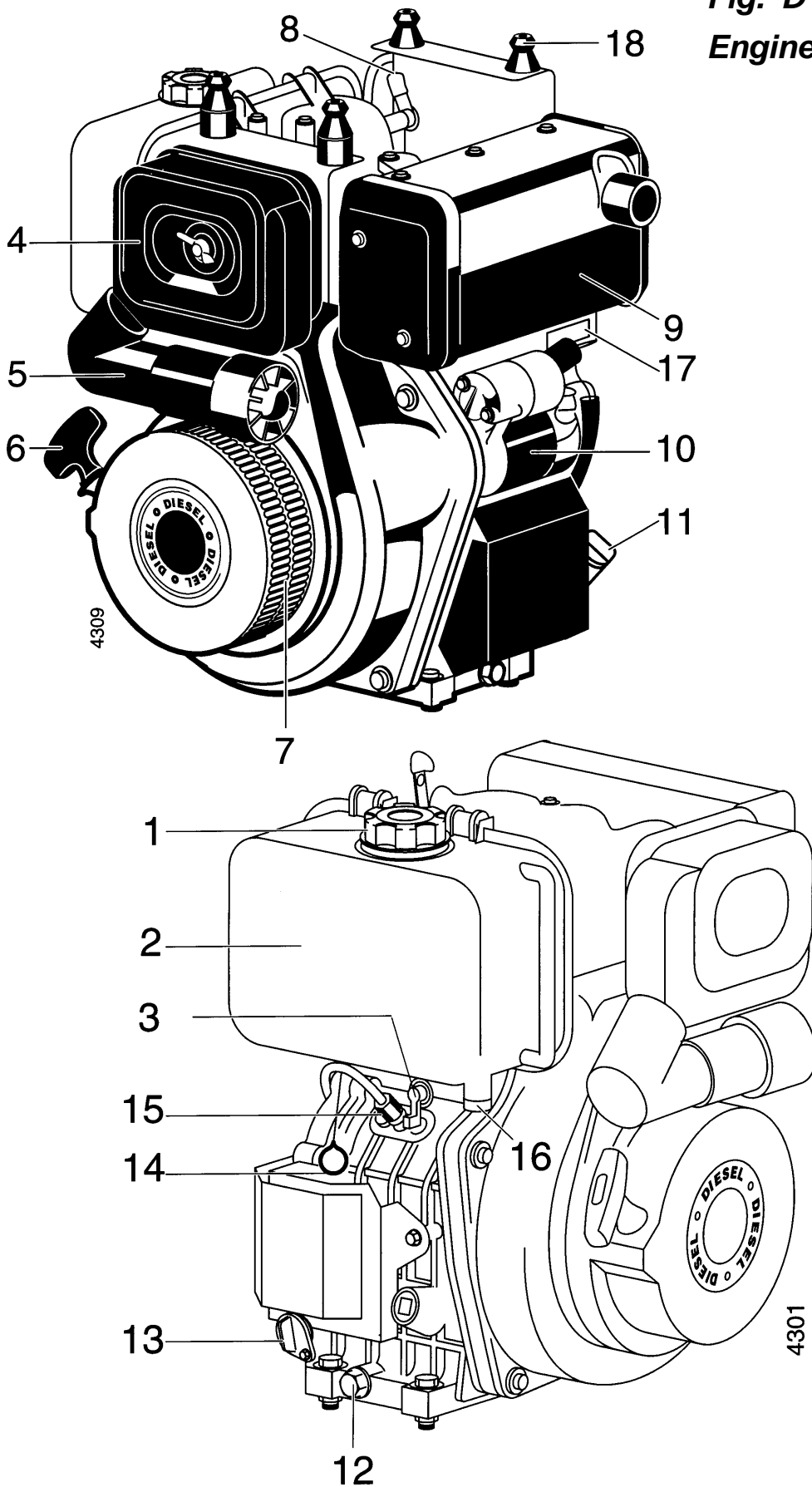

	A	After operating hours									min. every 3 months	min. yearly	B	page	
		2	4	8	25	50	100	200	300	400					
Check safety circuit function and engine shut-off switch function	◆ K														56
Check engine shut-off switch function	■ K														56
Check free play of levers	K														56
Clean cooling-screen	K														48/53
Check air-filter	K														46/51
Clean surrounding parts of exhaust	K		K												48/43
Check engine oil level, refill, if necessary	K			K											45/50
Check transmission oil level	K					K									54
Tighten wheel bolts and nuts		K			K										54
Check or clean speed control linkages	■			K											49
Cleaning					K										57
Check bolts and nuts					K										57
Clean air-filter	■				K						K				46
First engine oil change,	■				W										45
subsequent oil changes	■					W									45
Clean air-filter	◆					K					K				51
Lubricate coupling attachments						K							K		55
First engine oil change,	◆					W									50
subsequent oil changes	◆							W							50
Clean engine oil filter first time,	◆					W									50
subsequent cleaning	◆							W							50
First transmission oil change,						W									54
subsequent oil changes									W						54
Clean spark plug, adjust electrode gap	■							K							47
Clean guide plates, cooling fins – earlier, if required							W								48/53
Replace spark plug	■								K						47
Replace air filter insert, earlier, if required	■								K						46
Clean fuel filter	◆								W				W		52
Replace air filter insert, earlier, if required	◆										K		K		51
Replace fuel filter	◆									W					52
Clean carburetor and adjust	■										F				49
Clean cylinder head	■										F				49
Clean injection jet and check	◆										F				53
Adjust valve lash											F				49/53
Lubricate steering handle													K	K	55
Lubricate all gliding parts													K	K	57
Replace fuel hoses													W*		48/52

Figure E

Engine EH 25 D

- 1 Fuel tank cap
- 2 Fuel tank
- 3 Exhaust with guard
- 4 Engine oil plug with dip stick
- 5 Engine type plate
- 6 Engine drain plug
- 7 Support leg
- 8 Weight support
- 9 Cooling air screen
- 10 Starter handle
- 11 Spark plug and spark plug connector
- 12 Air filter
- 13 Choke-knob
- 14 Carburetor
- 15 Fuel tap

■ = Petrol Engine only

◆ = Diesel Engine only

A = Each time before you take up operation

B = After each cleaning

K = Checks and maintenance to be executed by operator

W = Maintenance to be executed by professional workshop

F = Maintenance should be carried out by your agria workshop

* = after 2 years

Fig. E

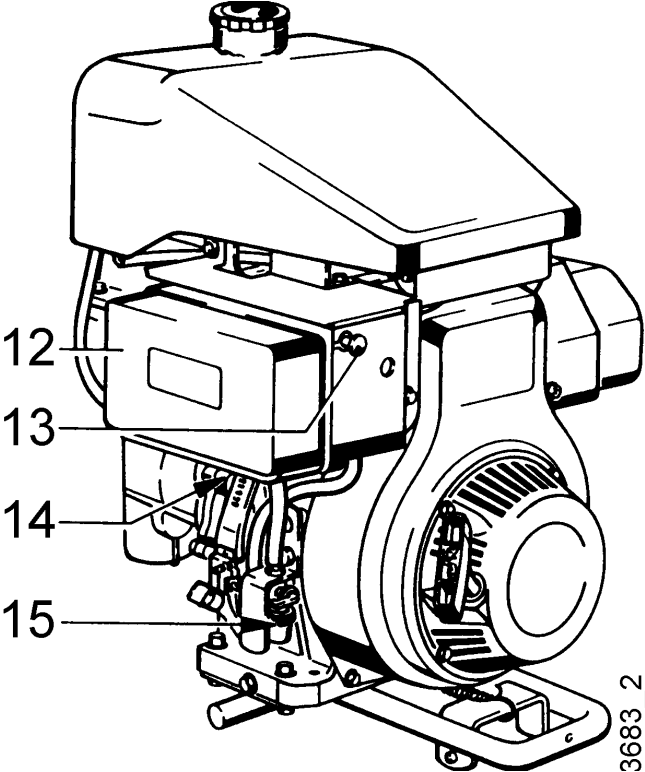

3683_2

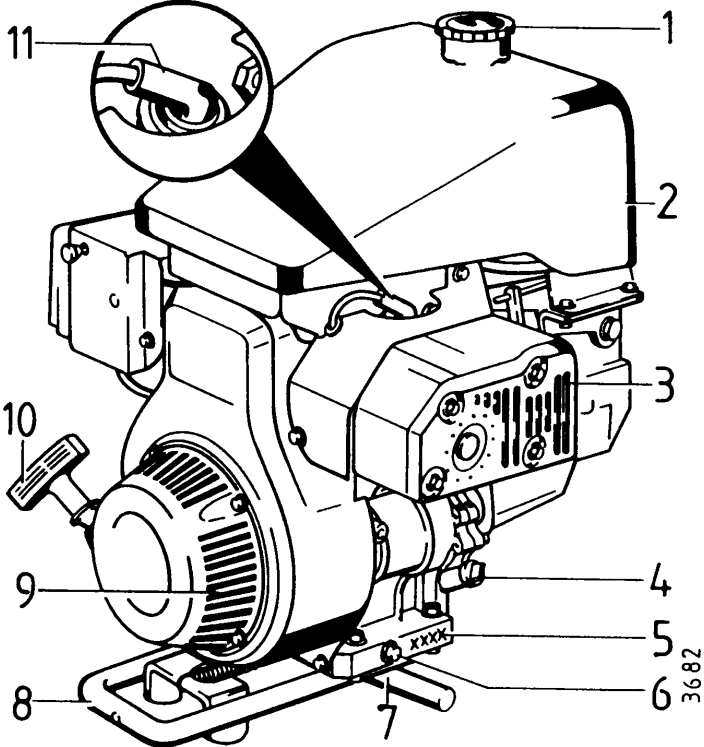

3682

EG-Konformitätserklärung
CE Déclaration de conformité
EC Declaration Conformity
EG conformiteitsverklaring

(D)

Wir

(F)

Nous

(GB)

We

(NL)

Wij

agri-Werke GmbH
Bittelbronner Str. 42
D-74219 Möckmühl/Württ.

erklären, dass das
Produkt

déclarons que le produit

herewith declare that
the product

verklaren dat het
produkt

Einachstraktor

Motoculteur

**Pedestrian controlled
tractor**

Eenassige tractor

3900 241; 3900 521

für die Verwendung in
der Land- oder
Forstwirtschaft

pour être utilisée dans
le domaine forestier,
pour l'entretien des
espaces verts et des
sols

for all common
applications and tasks
in forestry, grass and
park maintenance

bestemd voor gebruik in
de bosbouw, gras- en
weilandverzorging

mit folgenden
EG-Richtlinien
übereinstimmt:

est conforme aux
spécifications des
directives CE suivantes:

conforms to the
specifications of the
following EC directives:

overeenkomt met de
desbetreffende
EG-richtlijn:

**98/37/EG, 89/336/EWG,
2000/14/EG**

**98/37/CE, 89/336/CEE,
2000/14/CE**

**98/37/EC, 89/336/EEC,
2000/14/EC**

**98/37/EG, 89/336/EG,
2000/14/EG**

Angewendete Normen:

Standards appliqués:

Applied standards:

De volgende normen
zijn toegepast:

**EN 709, EN 12733,
EN ISO 14982**

Möckmühl, 02.01.2002



Siegfried Arndt
Geschäftsführer
Directeur
Managing Director
Bedrijfsleider



Karl Graf
Entwicklung & Konstruktion
Développement et études
Research and Development
Ontwikkeling en constructie

agria

agria-Werke GmbH

Bittelbronner Straße 42

D-74219 Möckmühl

Tel. +49/ (0)62 98/39-0

Fax +49/ (0)62 98/39-111

e-mail: info@agria.de

Internet: www.agria.de

Your local **agria** specialist dealer: