









INSTRUCTION MANUAL

FIRST MADE FOR	SAP-KC9,12,18,25,30AP
MATERIAL OR MODEL	*PAPER-JO
DIMENSION OR MAKER	WOODFREE 80gm
COLOR	BLACK Print
NOTE	A4 SIZE

APPROVALS N.Yamazaki 2010/Feb/1
CHECK Tai C.S 2010/Feb/1
DESIGN Tai C S 2010/Feb/1
DRAWN

				
				
				
				
				
				
				
				
APPROVALS		DATE	REVISIONS	R.NO

DRAWN

REMARKS:

SAMS ONLY

PART CODE

85S-6-4181-007-00-0

PART NAME

EXPLANATORY BOOKLET



INSTRUCTION MANUAL

Split System Air Conditioner

	INDOOOR UNIT		OUTDOOR UNIT
COOL / DRY MODEL	SAP-K9AP	—	SAP-C9AP
	SAP-K12AP	—	SAP-C12AP
	SAP-K18AP	—	SAP-C18AP
	SAP-K25AP	—	SAP-C25AP
	SAP-K30AP	—	SAP-C30AP

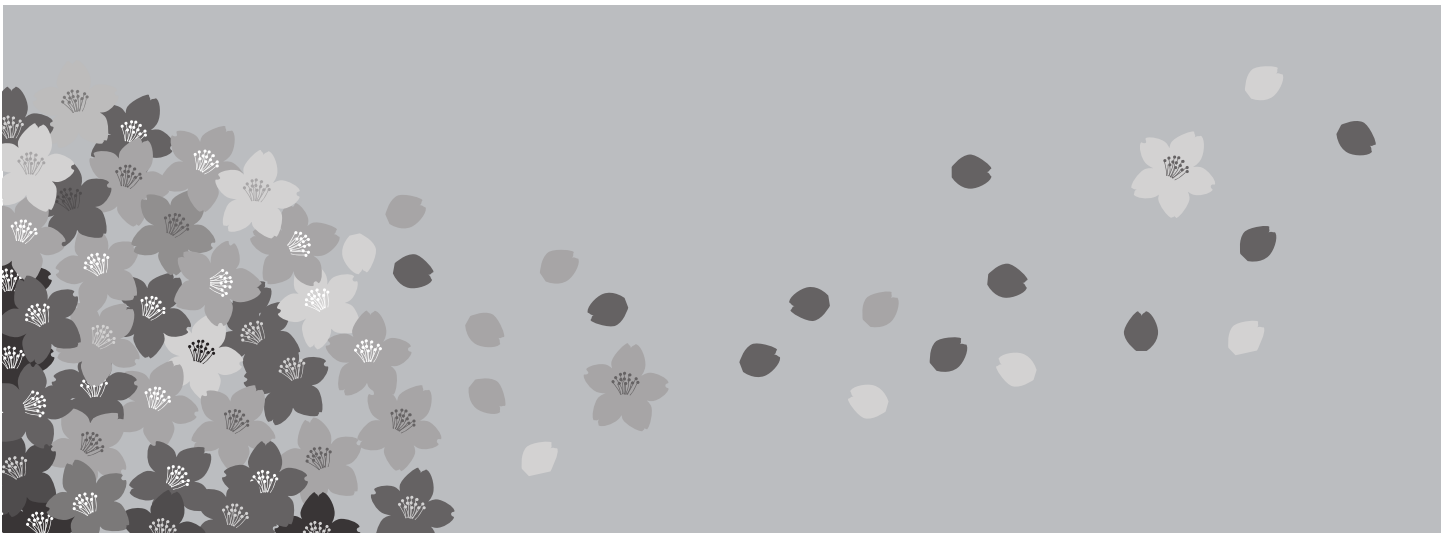

Save These Instructions!

Features

This air conditioner is equipped with cooling and drying functions. Details on these functions are provided below; refer to these descriptions when using the air conditioner.



24-hour Clock with ON/OFF Program Timer

The remote control unit allows you to set a wide variety of timer-based operations including automatic ON/OFF with timer setting, same-time ON/OFF every day, ON timer, OFF timer and Combination timer.



Automatic Fan Operation

Convenient microprocessor control automatically adjusts fan speed to High, Medium or Low, according to room temperature to maintain a comfortable airflow throughout the room.



Mild Dry

By coupling the compressor and fan operation, intermittent drying can be precisely controlled according to room temperature so that air is efficiently dehumidified.



Air Sweep Control

The air sweep function moves the flap up and down in the air outlet, directing air in a sweeping motion around the room and providing comfort to every corner.



Auto Clean

Fan operates when the unit is stopped to prevent the generation of mould and odors within the indoor unit.



Automatic Restart Function for Power Failure

Even when power failure occurs. Preset programmed operation is Reactivated once power resumes.



Humanized Sleep Function

Temperature gently rises or falls automatically to maintain comfortable room temperature and saves energy.



Self Diagnosis

Error code is displayed for fast and easy maintenance, should a problem occurs.



Rapid Cooling

The high-efficient system makes Cooling fast but still remains high EER/COP.

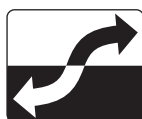

Low Voltage Startup (Min.198V)

The unit starts safely even when the voltage is below the rated voltage.



Super Quiet

Specially-designed air vent efficiently reduce noise.



Child Lock

Remote controller keys are lockable to prevent misoperation.



Turbo

Cools the room intensely.



Blue Fin

Anti-corrosion blue fin is more effective than a common coil.

Contents

	Page
Features	1
Operation and Maintenance	
1. Notices for operation	3
2. Notices for user	5
3. Names and functions of each part	6
4. Operation of wireless remote control unit	7
5. Clean and care	15
6. Troubleshooting	17
Installation Service	
7. Notices for installation	19
8. Installation dimension diagram	21
9. Install indoor unit	22
10. Install outdoor unit	26
11. Pump down	32
12. Check after installation and Test operation	33
13. Self diagnosis function	34

Product Information

If you have problems or questions concerning your Air Conditioner, you will need the following information. Model and serial numbers are on the nameplate on the bottom of the cabinet.

Model No. _____ Serial No. _____

Date of purchase _____

Dealer's address _____

Phone number _____

Thank you for choosing SANYO air conditioner, please read this instruction manual carefully before operating the unit and keep it carefully for consultation.

Alert Symbols

The following symbols used in this manual, alert you to potentially dangerous conditions to users, service personnel or the appliance:













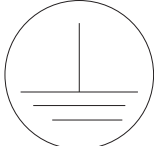

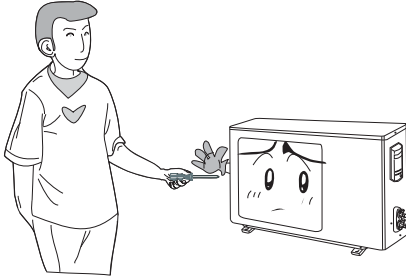
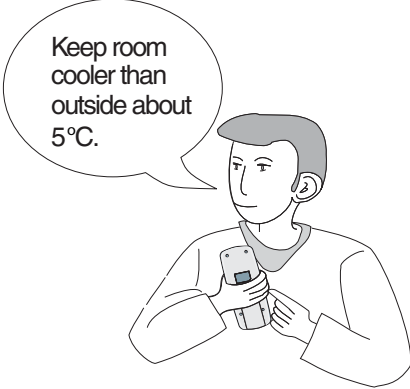
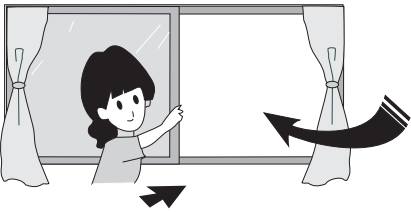
This symbol stands for the items should be forbidden.

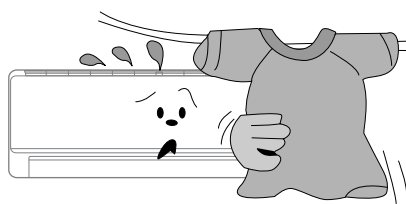

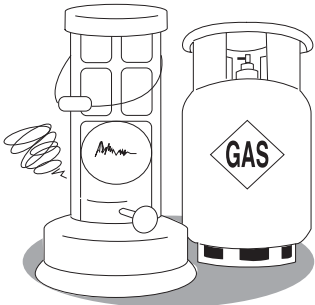
This symbol stands for the items should be followed.

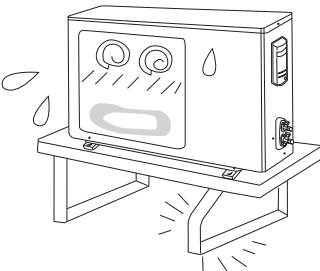
1. NOTICES FOR OPERATION

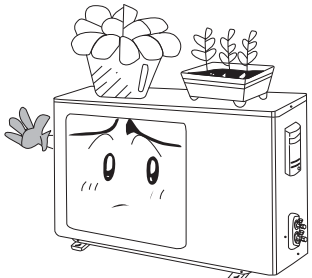
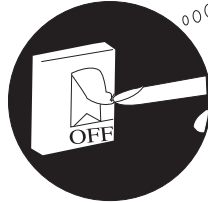
<p> ● Each unit must be properly grounded with a ground (or earth) wire or through the supply wiring.</p> <p> </p> <p>If not, please ask the qualified personnel to install. Furthermore, do not connect each wire to the gas pipe, water pipe, drainage pipe or any other improper places.</p>	<p>● Don't attempt to repair the air conditioner by yourself.</p> <p></p> <p></p> <p>The wrong repair will lead to an electric shock or fire, so you should contact the SANYO service center for repair.</p>	<p>● Select the most appropriate temperature.</p> <p></p> <p>Keep room cooler than outside about 5°C.</p> <p>It can help to preclude the electricity wasted.</p>
<p>● Don't leave windows and doors open for a long time while operating the air conditioner.</p> <p></p> <p>It can decrease the air conditioning capacity.</p>	<p>● Don't block the air intake or outlet vents of both the outdoor and indoor units.</p> <p></p> <p></p> <p>It can decrease the air conditioning capacity or cause a malfunction.</p>	<p>● Never use or store gasoline or other flammable vapor or liquid near the air conditioner.</p> <p></p> <p></p> <p>It is very dangerous and it may cause a fire or explosion.</p>
<p>● Please make sure whether the installed stand is firm enough or not.</p> <p></p> <p></p> <p>If it is damaged, it may lead to the fall of the unit and cause the injury.</p>	<p>● Do not step on the top of the outdoor unit or place things on it.</p> <p></p> <p></p> <p>As falling off the outdoor unit can be dangerous.</p>	<p>● If abnormal phenomenon (like burning odor, etc) occur, turn off power supply and contact SANYO service center.</p> <p></p> <p>Cut Off Power</p> <p>If abnormal phenomenon continues, the unit may be damaged and cause electric shock or fire.</p>

1. NOTICES FOR OPERATION

- Do not use the air conditioner for other purposes, such as drying clothes, preserving foods, etc.

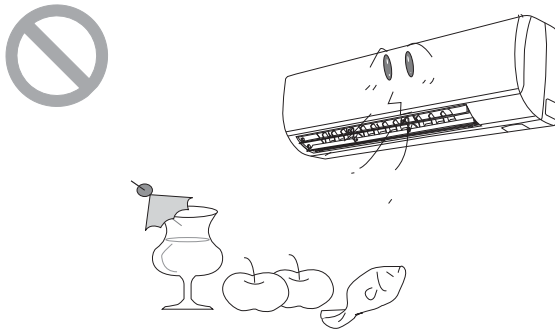

- Do not place a space heater near the air conditioner. CO toxicosis may occur as a result of incomplete burning.

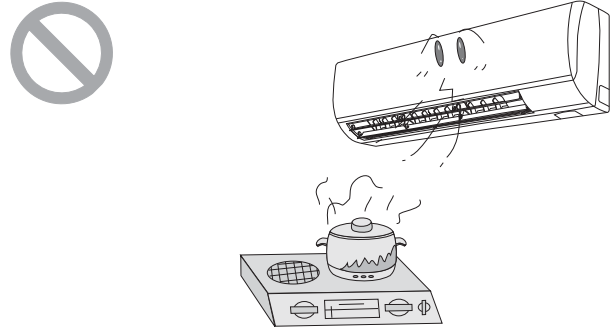

- Do not insert your hands or stick into the air intake or outlet vents.

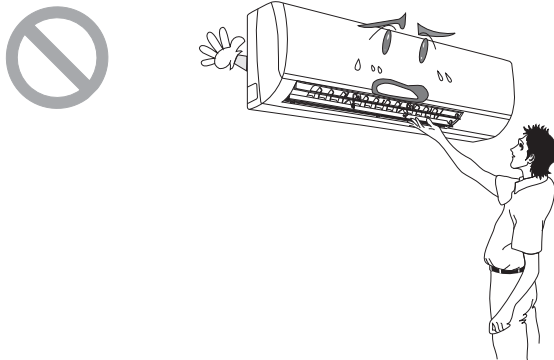

- Do not blow the wind to animals and plants directly. It can cause a bad influence to them.

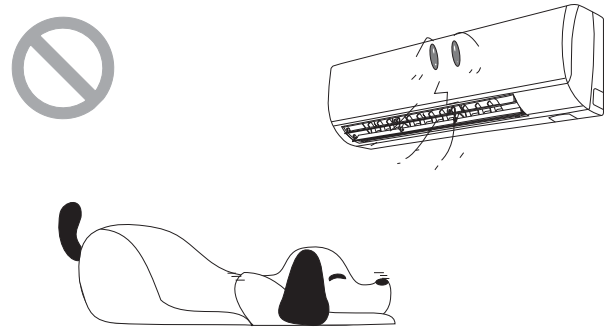

- Splashing water on the air conditioner can cause electric shock or malfunction.

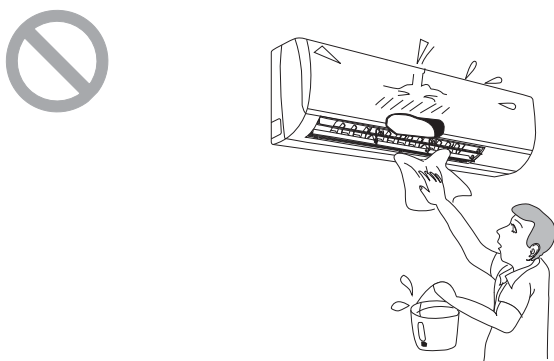

- Adjusting the airflow direction correctly.

a) Horizontal:

The horizontal airflow can be adjusted by moving the louver with your hand to the left or right.

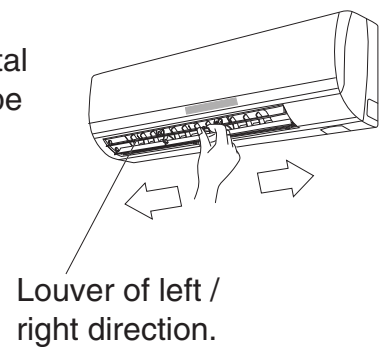

b) Vertical:

The vertical air flow can be adjusted by moving the flap with the remote control unit. Use the SWING button to set either the auto sweep or set to the recommended position.

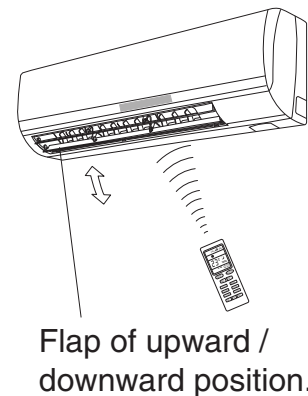

- Do not apply the cold wind to the body for a long time. It can cause the health problems.

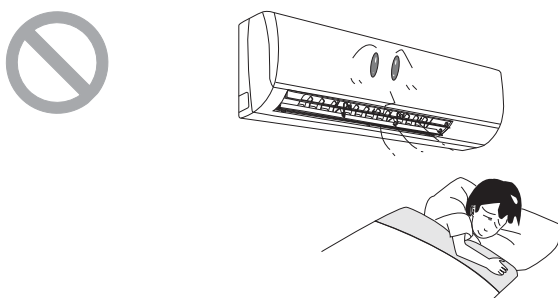

2. NOTICES FOR USER

2.1 Working Principle & Special Functions for Cooling

Principle:

Air conditioner absorbs heat in the room and transmit to outdoor and discharged, so that indoor ambient temperature decreased. It's cooling capacity will decrease by the increase of outdoor ambient temperature.

Anti-freezing Function:

If the units is running in COOL mode and in low temperature, there will be frost formed on the heat exchanger, when indoor heat exchanger temperature decreased below 0 °C, the indoor unit micro-computer will stop compressor running and protect the unit.

2.2 Working Temperature Range

	Temperature	Indoor air temperature	Outdoor air temperature
COOLING	Max.	32 °C DB / 23 °C WB	52 °C DB / ---
	Min.	21 °C DB / 15 °C WB	21 °C DB / ---

The operating temperature range (outdoor temperature) for cooling unit is 21 °C ~ 52 °C.

2.3 The Conditions of Unit Can't Operate Normally.

In the following temp. range, the protection device may act, this may cause unit stop running.

	Outdoor temperature above	Outdoor temperature below	Indoor temperature above
“COOL” running	52°C	21°C	32°C
“DRY” running	52°C	18°C	32°C

Under the relative humidity is above 80% (doors and windows are opened) when cooling or dehumidifying for a long time, there may have dew drip off near the air vent.

3. NAMES AND FUCTIONS OF EACH PART

Indoor Unit

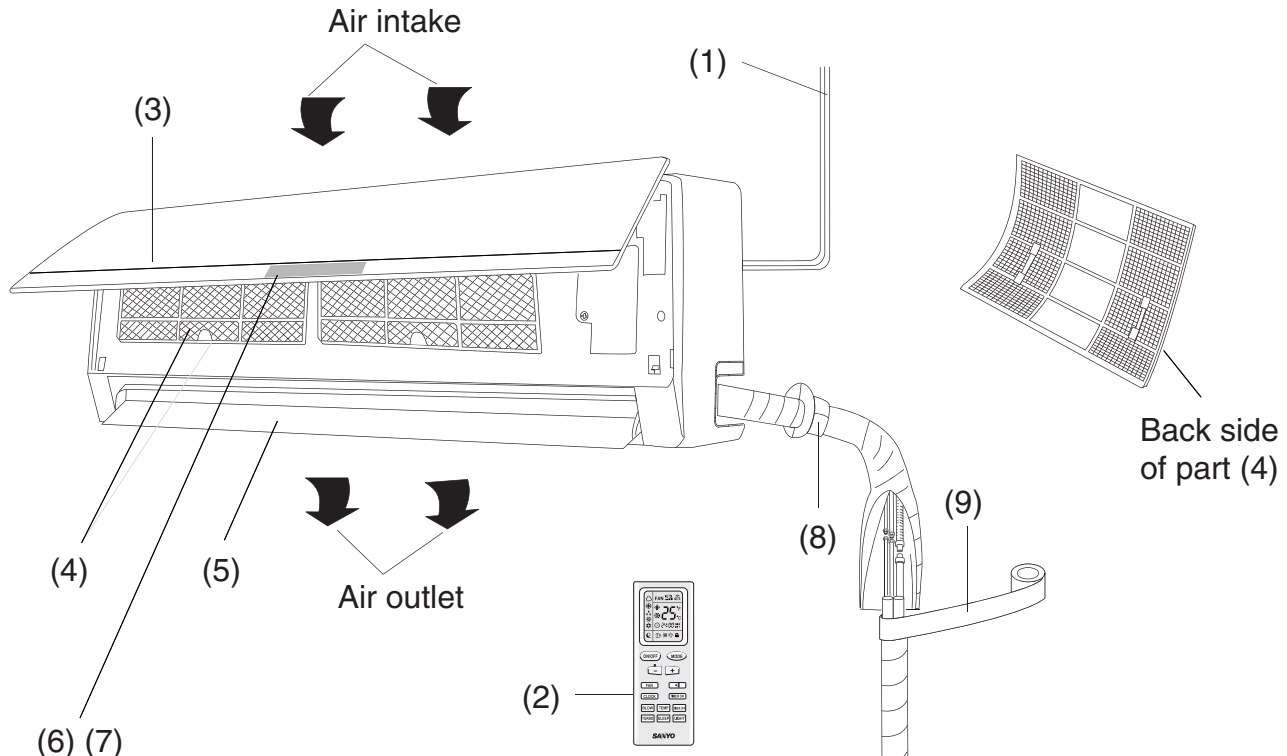

The pattern in displayer:

- ☀ : Cool
- 💧 : Dry
- 🌀 : Fan
- ⏻ : Run
- BB : Set temp.

Outdoor Unit

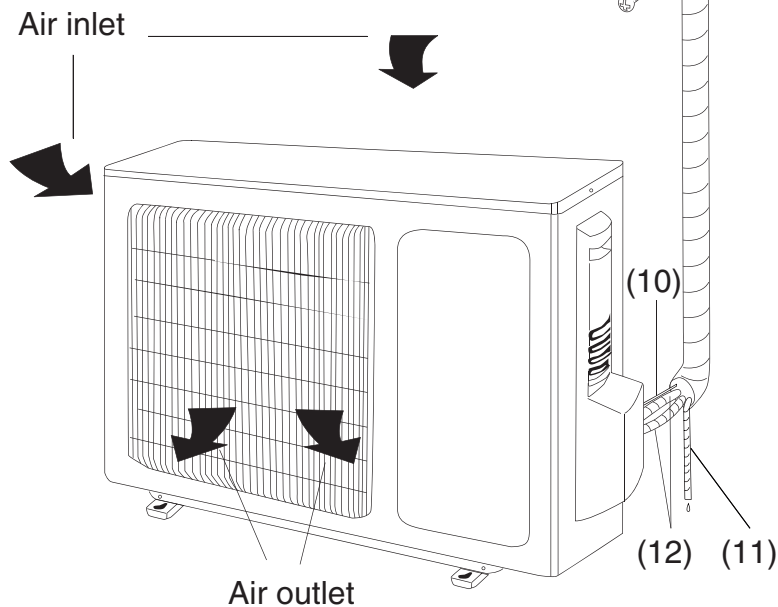

S/n	Part Name
(1)	Power cable
(2)	Remote control
(3)	Front Panel
(4)	Filter
(5)	Guide Louver
(6)	Receiver
(7)	Indicator Cool Dry Fan Run Set Temp.
(8)	Wall Pipe
(9)	Bind Tape
(10)	Connection Wire
(11)	Drainage Pipe
(12)	Connection Pipe

4. OPERATION OF WIRELESS REMOTE CONTROL UNIT

4.1 Remote Control Unit (Display)

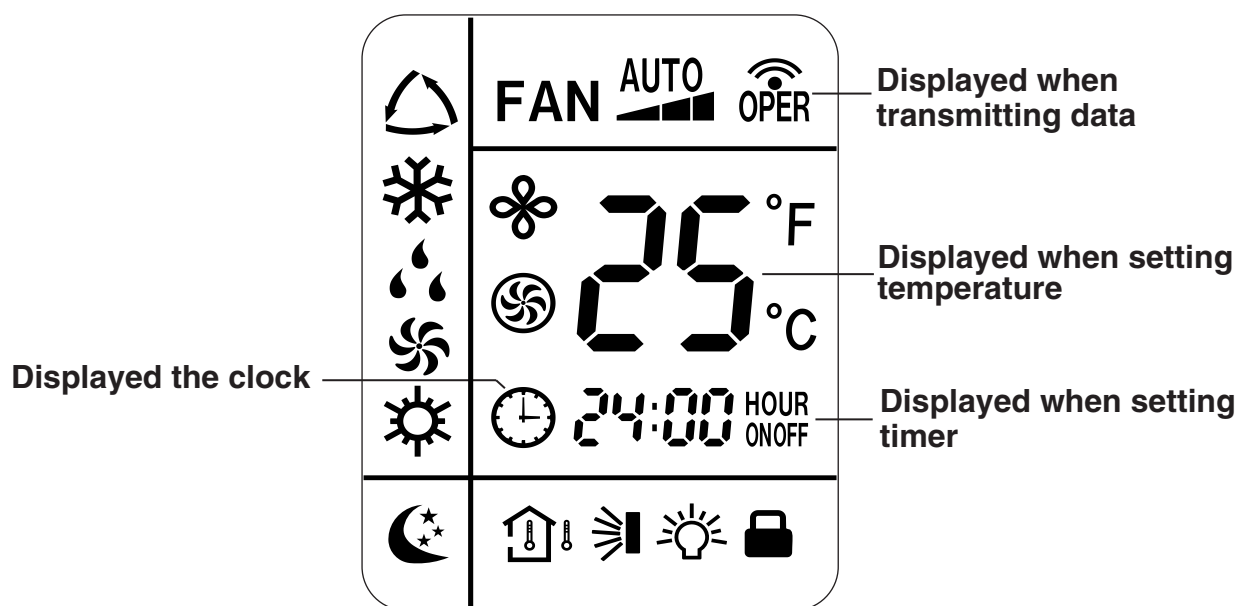

Symbols

(1) Operation mode

AUTO



COOL

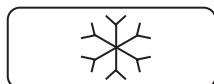

DRY.....



FAN



HEAT

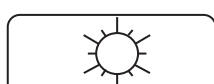

(Not for cooling only model)

(2) Fan speed

Automatic operation.....



HIGH.....



MID.....



LOW



(3) Set temperature

16 – 30 °C
When set to 23 °C ...

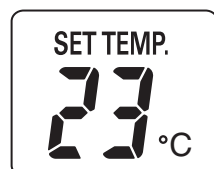

(4) Timer

24-hour ON Timer



24hour OFF Timer.....



(5) Sleep



(6) Confirmation of transmission



(7) Clock indication



(8) Sweep indication



(9) Light



(10) Blow



(11) Turbo



(12) TEMP











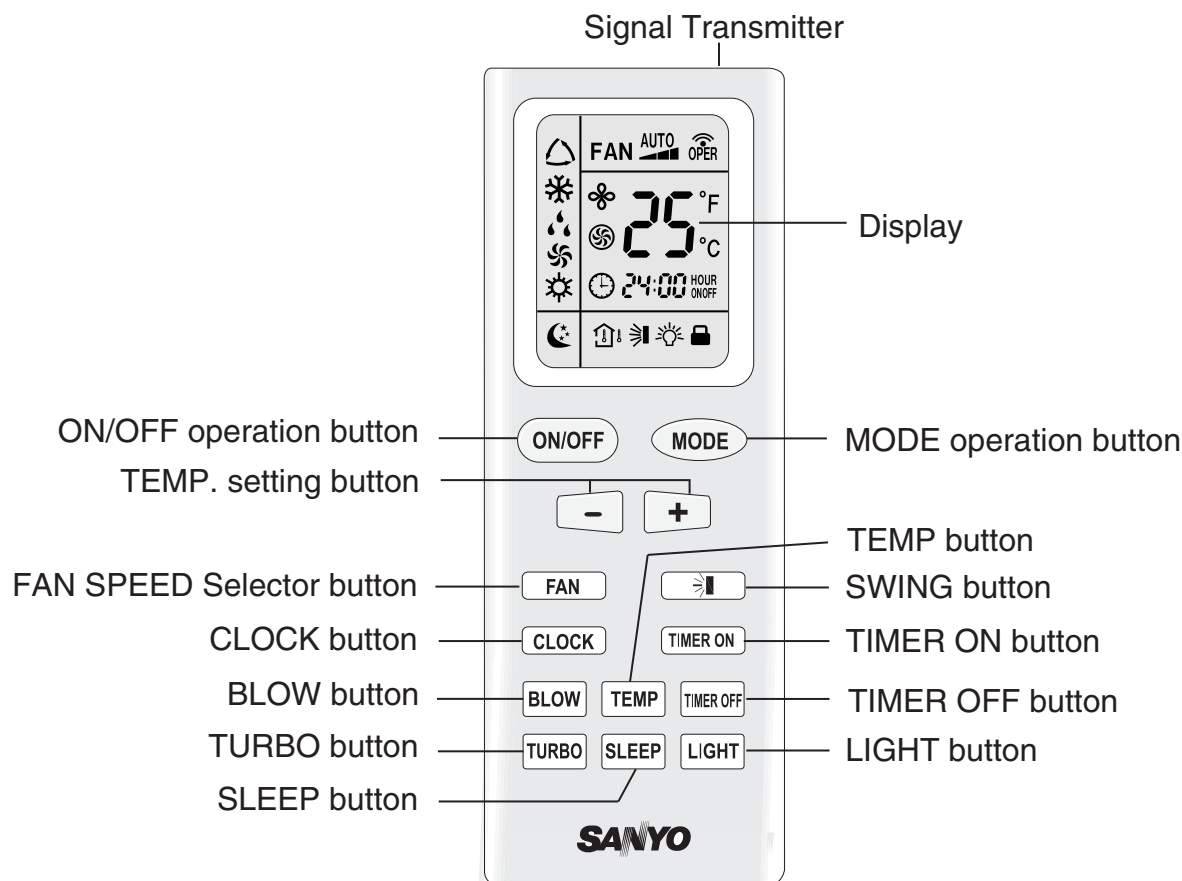



(13) Lock



4. OPERATION OF WIRELESS REMOTE CONTROL UNIT











4.2 Remote Control Unit (Functions)

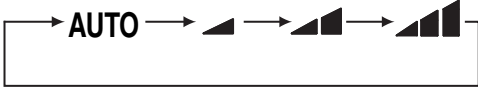

Transmitter	When you press the buttons on the remote control unit, the  mark appears in the display to transmit the setting changes to the receiver in the air conditioner.
Display	Information on the operating conditions is displayed while the remote control unit is switched on. If the unit is turned off, only CLOCK and TEMP was displayed.
ON/OFF operation	This button is for turning the air conditioner ON and OFF.
MODE selector button (AUTO)	To select "AUTO" "COOL", "DRY" or "FAN" mode.
(COOL)	 : When choosed this setting, the air conditioner calculates the difference between the thermostat setting and the room temperature and to select suitable running method.
(DRY)	 : The air conditioner makes the room cooler.
(FAN)	 : The air conditioner reduces the humidity in the room.
(HEAT)	 : The air conditioner run the indoor fan only.
	 : NOT function for cooling only model.
(+) / (-) setting buttons	 : Press the (+) button to increase set temperature, continue press 2 seconds for fast increasing set temperature.  : Press the (-) button to reduce set temperature, continue press 2 seconds for fast reducing set temperature.
LOCK / UNLOCK button	 : Press the  button at the same time to lock or unlock wireless remote controller.
TIMER ON button	 ON : The air conditioner starts at the set time.
TIMER OFF button	 OFF : The air conditioner stops at the set time.

4. OPERATION OF WIRELESS REMOTE CONTROL UNIT

4.2 Remote Control Unit Functions (Continued)

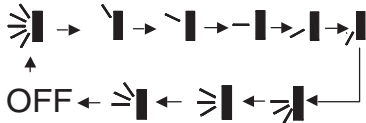
<p>FAN SPEED selector button</p>	<p>AUTO : The air conditioner automatically decides the fan speeds.</p> <p>  : Low fan speed.  : Medium fan speed.  : High fan speed. </p> 
<p>TEMP button</p> <p>NOTE</p>	<p>Press to see set temperature or indoor temperature which show on the indicator lamp according to customer requirement.</p> <p>  : Display the presetting temperature.  : Display the indoor ambient temperature (5 seconds) It will display the ambient temperature for 5 seconds, After 5s later, then will back to display the presetting temperature. </p> <p>  : Current displaying status will not be changed. No Icon : Default to display the pesetting temperature. </p>
<p>BLOW button</p>	<p>Press to begin or stop indoor fan from blowing indoor components to dry. This function applicable to “COOL” & “DRY” mode only. In “AUTO” & “FAN”, “BLOW” function can not be set up and there is no “BLOW” displaying.</p>
<p>LIGHT button</p>	<p>Press this button will turn ON / OFF the display of indicator light.</p>
<p>TURBO button</p>	<p>Press to quickly cool or heat the room with intense cool or hot air.</p>
<p>SLEEP button</p>	<p>For details, see “SLEEP MODE” (P.g 12). When you press this button in the “DRY” or “COOL” mode, the  mark appears in the display, and the remote control unit will automatically adjust the set temperature to save energy.</p>
<p>CLOCK Button</p>	<p>Use this button to set the clock.</p> <p>How it Works?</p> <p>Press clock button, signal  blink and display. Within 5 seconds, the value can be adjusted by pressing “+” or “-” button, if press this button continuously for 2 seconds and above, in every 0.5 seconds, the value on ten place of Minute will be increased 1. During blinking, repress the Clock button, signal  will be constantly displayed and it denotes the setting succeeded. After powered on, 12:00 is defaulted to display and signal  will be displayed. If there is signal  be displayed that denotes the current time value is Clock value, otherwise it is a Timer value.</p>
<p>SWING Button</p> <p>NOTE</p>	<p>To set the air swing direction which circularly change as:</p>  <p>When the guide louver start to swing up and down, if turn off the Swing, the air guide louver will stop at the current position. (refer P.g 13 for more detail)</p>

4. OPERATION OF WIRELESS REMOTE CONTROL UNIT

4.3 Using the General Operation

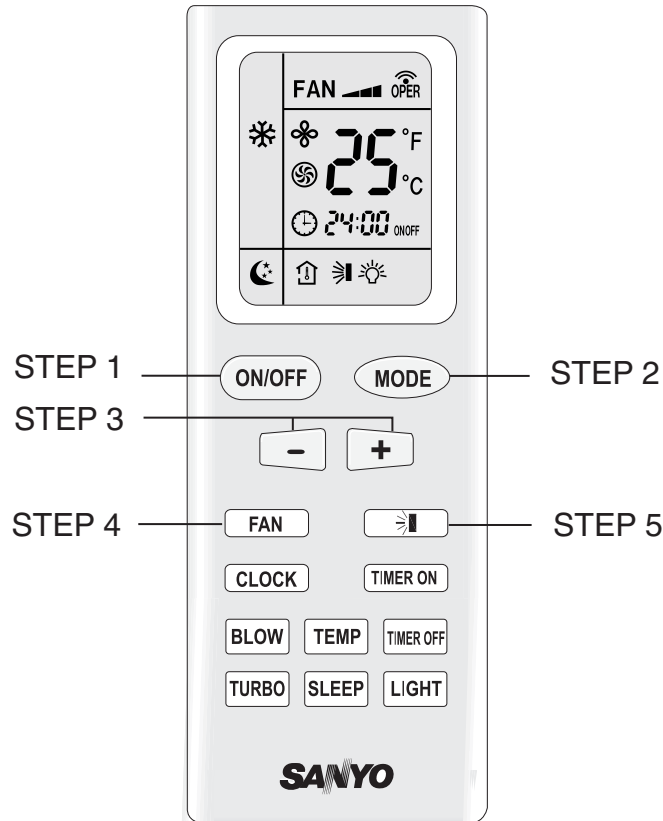

NOTE Press the setting buttons as described below and change the settings as desired.

STEP 1	To start the air conditioner, press the ON/OFF operation button.
STEP 2	Press the MODE selector button and select the desired mode. For DRY operation → ☁ For COOLING operation → ❄ For FAN only operation → 🌀 For AUTO operation → △ For HEATING operation → ☀ (Not function for cooling only model)
STEP 3	Press the TEMP. setting buttons to change the temperature setting to the desired temperature. Adjustable temperature range: 30 °C (86 °F) max.—16 °C (61 °F) min. Under “AUTO” operation, the temperature can not be adjust. Under other operation, the initial value is 25 °C (77 °F).
STEP 4	Set the FAN SPEED selector button to the setting you want. AUTO : Auto fan speed. ▾ : Low fan speed. ▴ : Middle fan speed. ▴▴ : High fan speed.
NOTE	Under Dry mode, the fan speed is automatically set to LOW.
STEP 5	Press the 🌀 button and set the air blow direction as desired or automatically.

To STOP the air conditioner, press the ON/OFF operation button again.

4. OPERATION OF WIRELESS REMOTE CONTROL UNIT

4.4 Using the 24-Hour “ON” or “OFF” Timer

4.4.1 TIMER ON mode (Example)

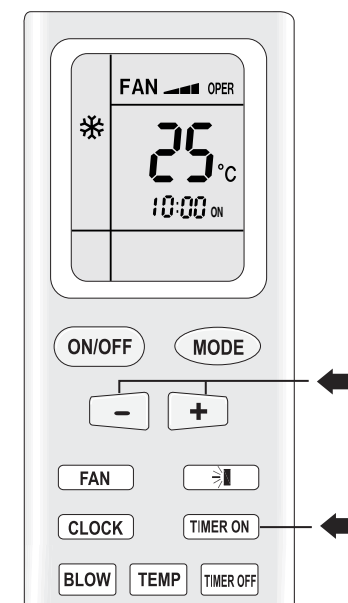

After the length of time set for **TIMER ON** elapses, the unit begins operating.

The display depicted at left indicates that the air conditioner will begin operating in 10 hours.

Setting procedure:

STEP 1	Press the “ON/OFF” button and press “MODE” button to set the desired operation mode. (See “Operation with the Remote Control Unit”, Pg10). Again, press the “ON/OFF” button to “OFF” the unit.
STEP 2	Press the “TIMER-ON” button.
STEP 3	Press the “T-ON” button (which advances the clock displayed) to set the time at which you want operation to begin. The time can be set for 1 min. intervals for 24 hrs. Hold pressing (+) / (-) button, it quickly change the time value. Press the “T-ON” button again to confirm the set time is 10 A.M.

- The display changes immediately to **CLOCK**, but the  indication remains.
- To check the status of the timer while it is counting down, press the “TIMER-ON” button.

Cancellation Procedure : Press the “TIMER ON” button again to cancel.

4.4.2 TIMER OFF mode (Example)

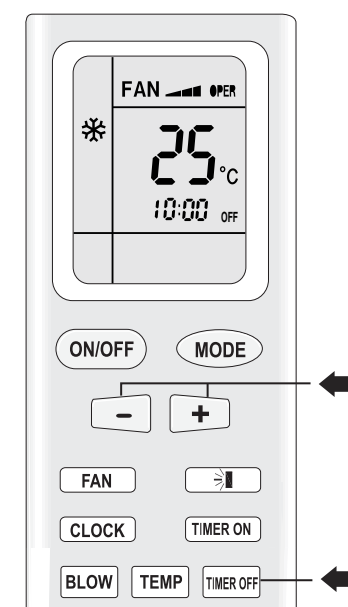

After the length of time set for **TIMER OFF** elapses, the unit stops operating.

The display depicted at left indicates that the air conditioner will stop operating in 10 A.M.

Setting procedure:

STEP 1	Press the TIMER OFF button.
STEP 2	Press the “T-OFF” button (which advances the clock displayed) to set the time at which you want operation to stop. The time can be set for 1 min. intervals for 24 hrs. Hold pressing (+) / (-) button, it quickly change the time value. Press the “T-OFF” button again to confirm the off time is 10 A.M.

- The display changes immediately to **CLOCK**, but the  indication remains.
- To check the status of the timer while it is counting down, press the “T-OFF” button.

Cancellation Procedure : Press the “TIMER OFF” button once again.

4. OPERATION OF WIRELESS REMOTE CONTROL UNIT

4.5 Using the SLEEP Operation

In Cooling and DRY Mode : (* and ☼)

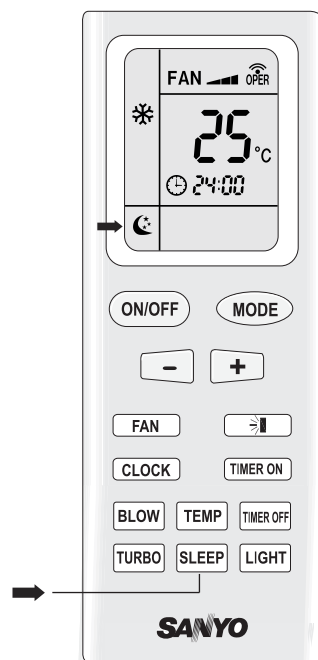

SLEEP Mode is used for saving energy.

Press the SLEEP button while operation.

The ☾ mark appears in the display.

To release the SLEEP function, press the SLEEP button again.

When the SLEEP mode is selected, the air conditioner automatically raises the temperature setting 1 °C when 60 minutes have passed after the selection was made, and then another 1 °C after another 60 minutes have passed, regardless of the indoor temperature when SLEEP was selected. Afterwards, the unit will remain this temperature. This enables you to save energy without sacrificing comfort. This function is convenient when gentle cooling is needed.

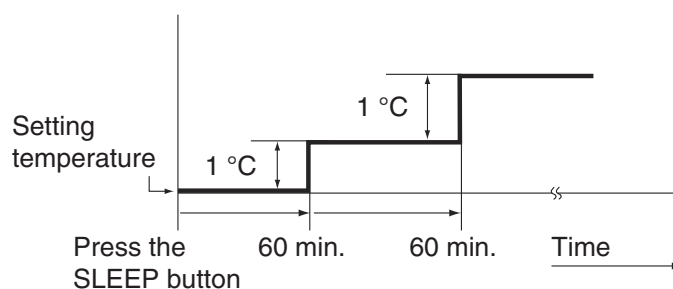

4.6 Using of the “Special” Features



**“DRY”
Operation**

How it works?

- While DRY operation, fan speed is automatically set to LOW.
- If the room temp. is 2 °C higher than the Set Temperature, the unit will run in COOL mode.
- Once the room temp. reaches ± 2 °C of the level that was set, the unit repeats the cycle of compressor turning “ON” 6 mins and turning “OFF” 4 mins automatically.



**“AUTO”
Operation**

How it works?

- When AUTO mode is selected, the default temperature will be displayed on the LCD, the unit will be in accordance with the room temperature automatically to select the suitable running method and to adjust ambient comfortable.



**“BLOW”
Operation**

How it works?

This function indicates that moisture on evaporator of indoor unit will be blown after the unit is stopped to avoid mould. Once blow function is on, while the unit is off by pressing the ON/OFF button, the indoor fan will continue running for about 10 min. at low speed. In this period, press “BLOW” button again can stop indoor fan directly.

4. OPERATION OF WIRELESS REMOTE CONTROL UNIT

4.6 Using of the “Special” Features (Continued)



**“TURBO”
Operation**

How it works?

During “COOL” mode, if start this function, the unit will run at super-high fan speed to cool quickly so that the ambient temp. approaches the preset temp. as soon as possible.



**“LIGHT”
Operation**

How it works?

It's a special selective button for the users , who are not accustomed to the light at sleeping.

Setting “ON” the displayer indicator light

When setting the light function, the mark  will display on the remote controller screen by pressing this button. In which case, the displayer indicator light will be on if the AC receives this signal.

Setting “OFF ” the displayer indicator light

To cancel the light function, the mark  will disapper on the remote controller screen. In which case, the displayer indicator light will be off if the unit receives this signal.



**“LOCK”
Operation**

How it works?



Press “+” and “-” buttons simultaneously to Lock / Unlock the keyboard. If the remote controller is locked, the  will be displayed on it, inwhich case, press any button, the mark will flicker for three times. If the keyboard is unlocked, the mark will disappear.



**“SWING”
Operation**

How it works?

About Swing Up and Down

1. Press swing up and down button continuously more than 2s, the main unit will swing back and forth from up to down, and then loosen the button, the unit will stop swinging and present position of guide louver will be kept immediately.
2. Under swing up and down mode, when the status is switched from off to , if press this button again 2s later,  status will switch to off status directly; if press this button again within 2s, the change of swing status will depend on the circulation sequence stated below:

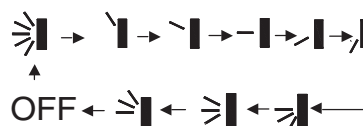

**“ °F ” / “ °C ”
Operation**

How it works?

About switch between Fahrenheit and Centigrade.

Under status of unit off, press “MODE” and “-” buttons simultaneously and release both button immediately will switch in °C and °F.

**Power Failure
During Operation**

How it works?

In the event of power failure, the unit will stop. When the power is resumed, the unit will restart automatically after 3 minutes.

4. OPERATION OF WIRELESS REMOTE CONTROL UNIT

4.7 How to Install Batteries

1. Slightly to press the place with  , along the arrowhead direction to push the back cover of wireless remote control. (Fig. 1)
2. Take out the old batteries. (Fig. 1)
3. Insert two new AAA1.5V dry batteries, and pay attention to the polarity. (Fig. 2)
4. Attach the back cover. (Fig. 2, procedure 4)

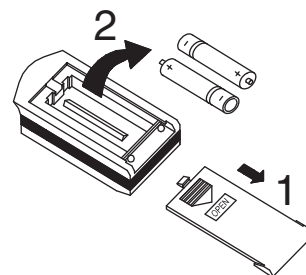
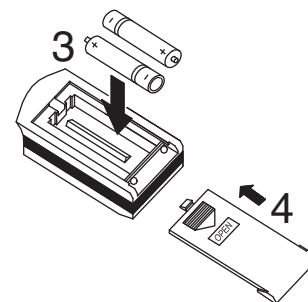

Fig. 1



Sketch map for changing batteries

Fig. 2

NOTE

- The batteries last about six months. Replace the batteries when the remote control unit's display fails to light, or when the remote control cannot be used to change the air conditioner's settings.
- When changing the batteries, do not use the old or different batteries, Use two fresh leak-proof type -AAA alkaline batteries, otherwise, it can cause the malfunction of the wireless remote control.
- If the wireless remote control will not be used for more than one month, please take them out, and don't let the leakage liquid damage the wireless remote control.
- It should be placed at where is 1m away from the TV set or stereo sound sets. If the wireless remote control can not operate normally, please take them out, after 30s later and reinsert, if they can't normally run, please change them.
- The remote control signal can be received at a distance of up to about 4meter.

4.8 Using the Remote Control Unit

When using the remote control unit, always point the unit's transmitter head directly at the air conditioner's receiver. (Fig. 3)

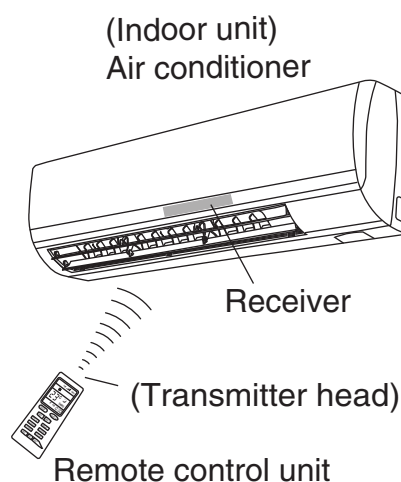

Fig. 3

4.9 Emergency Operation

If the wireless remote control is lost or broken, please use the manual switch button. At this time, the unit will run at the "AUTO" mode, but the temperature and fan speed cannot be changed. (Fig. 4)

To open the panel, the manual switch is located on the displayer box. The operation was shown as below:

• Turn "ON" the Unit:

At unit turned off, press the button, the unit will run at Auto mode immediately. The microcomputer will accord to the indoor temperature to select (Cooling, Heating or Fan) and obtain the comfortable effect.

• Turn "OFF" the Unit:

At unit turned on, press the button, the unit will stop working.

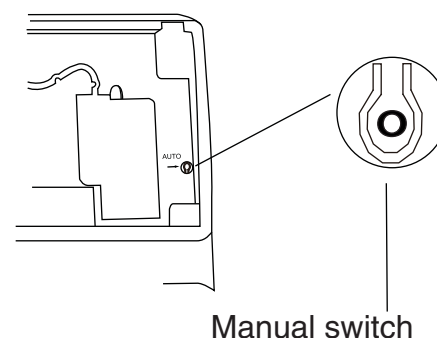

Fig. 4

5. CLEAN AND CARE

! CAUTION

1. For safety, be sure to turn the air conditioner off and also disconnect the power before cleaning. Or it may cause electric shock.
2. Never sprinkle water on the indoor unit and the outdoor unit for cleaning because it can cause an electric shock.
3. Volatile liquid (e.g. thinner or gasoline) will damage the air conditioner. (So wipe the units with a dry soft cloth, or a cloth slightly moistened with water or cleanser.)

5.1 Clean the Front Panel

(Make sure to take it off before cleaning)

1. Take off the front panel

Push in both ends of grooves to the shown position beside at the same time by the arrow direction. (Fig. 4a, 4b)

2. Washing

Clean with a soft brush, water and neutral detergent, and then to dry it with a clean soft cloth. (Fig. 5)

NOTE Do not use hot water which temperature above 45°C to prevent fade or deformation.

3. Put on front panel

Insert the supports on both ends of panel into groove, and put the mid rotating shaft in groove, cover the panel cover according to arrow direction and cover well. (Fig. 6a,6b)

5.2 Cleaning the Air Filters

(Recommended once every 3 months)

- NOTE**
1. There are microcomputer components and circuit diagram on the LCD of front panel.
 2. After taking off the filter, some metal edges and the fins are sharp and may cause injury if handled improperly; be especially careful when you clean these parts.
 3. If dust is much more around the air conditioner, the air filters should be cleaned more often.
 4. The internal coil and other components of the outdoor unit must be cleaned every year. Consult your dealer or service center.

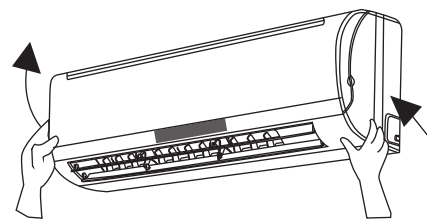

Fig. 4a

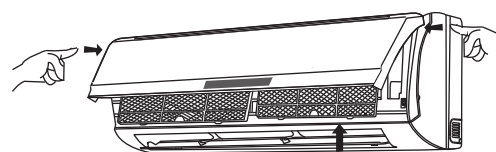

Fig. 4b

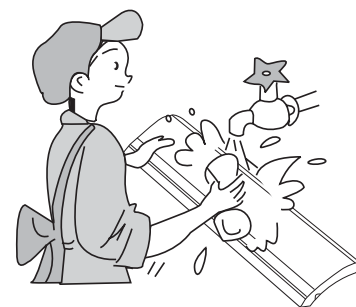

Fig. 5

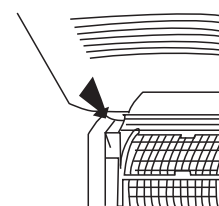

Fig. 6a

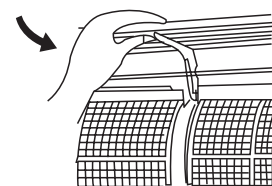

Fig. 6b

5. CLEAN AND CARE

5.2 Cleaning the Air Filters (Continued)

1. Take Down the Air Filters

Pull out the panel to an angle at bottom grooves on panel. And, pull the air filter upward then downward to take it off. (Fig. 7).

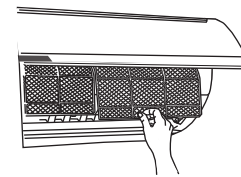

Fig.7

2. Cleaning

To clean the dust adhering to the filters, you can either use a vacuum cleaner, or wash them with warm water (the water with the neutral detergent should be below 45 °C) when the filters are very dirty (such as soil stain), and dry it in the shade. (Fig.8)

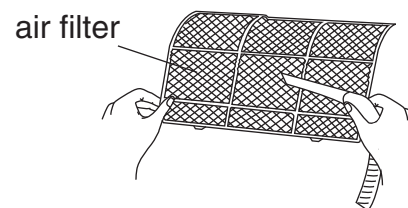

Fig.8

NOTE Don't use hot water which temperature is above 45°C to prevent fade or deformation.

Don't dry it on fire for filter, it would catch a fire or deformation.

3. Put back the filter

Put back the filter, then cover the surface panel well. (Fig. 9)

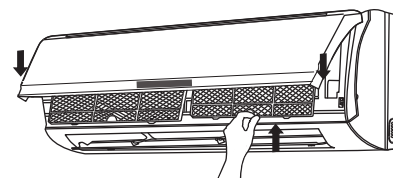
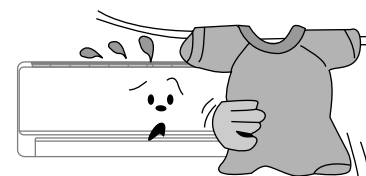

Fig.9

5.3 Check Before You Use

1. Be sure that nothing obstructs the air outlet and intake vents. (Fig.10)
2. Check that whether ground wire is properly connected or not.
3. Check that whether the batteries of air conditioner are changed or not.
4. Check that whether installation stand of the outdoor unit is damaged or not. If damaged, please contact the dealer.



5.4 Maintain After Use

1. Turn main power off.
2. Clean the filter, indoor and outdoor units' bodies.
3. Clear dust and obstructions from the outdoor unit.
4. Repaint the rubiginous place on the outdoor unit to prevent it from spreading.

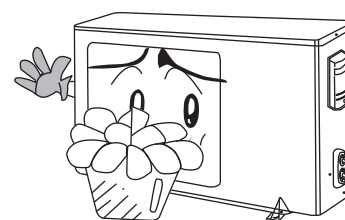
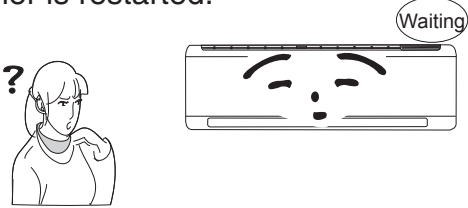
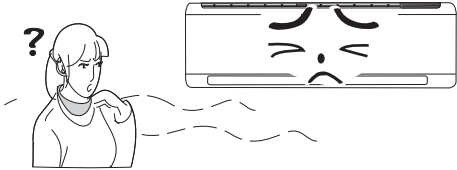
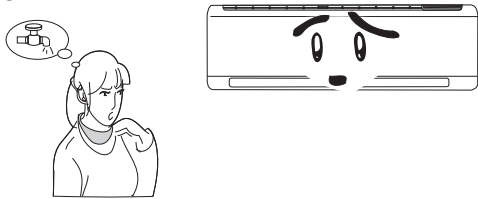
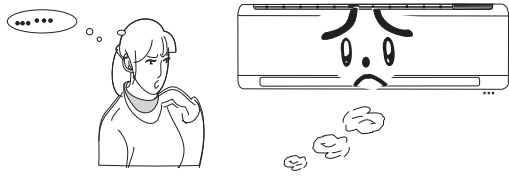
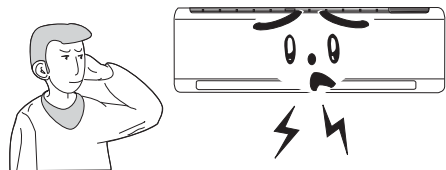

Fig.10

6. TROUBLESHOOTING

! CAUTION

Don't attempt to repair the air conditioner by yourself, it can cause an electric shock or fire. Please check the following items before asking for repair, it can save your time and money.

Phenomenon	Troubleshooting
<p>Do not operate immediately when the air conditioner is restarted.</p> 	<p>Once the air conditioner is restarted immediately after turned off, the overload protection switch will make it run after a 3-minute delay.</p>
<p>There is an unusual smell blowing from the outlet after operation is started.</p> 	<p>The unit has no peculiar smell by itself. If this happens, it is the smell accumulated in the ambient. Solution: Clean the air filters (see Pg.15). If the problem still persists, the unit requires servicing. Hence, please contact with SANYO authorized maintenance center.</p>
<p>Sound of water flow can be heard during operation.</p> 	<p>Sometimes there is a swoosh or gurgle when the air conditioner is started, stopped, or when the compressor starts or stops running. The sound is due to refrigerant flowing. These are not malfunctions.</p>
<p>Mist is emitted.</p> 	<p>When indoor temperature and humidity are high, this phenomenon may occur. This is caused by the room air being cooled down. After running for a while, the indoor temperature and humidity will decrease, and the mist will disappear.</p>
<p>Creaking noise can be heard when starting or stopping the unit.</p> 	<p>This is caused by the deformation of plastic due to temperature changes.</p>

6. TROUBLESHOOTING

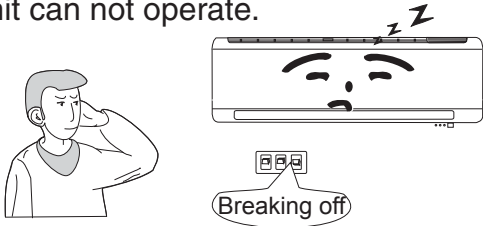
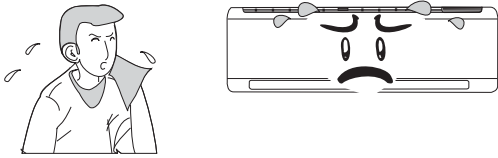
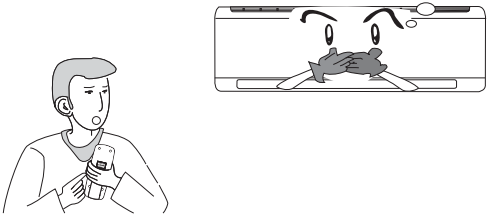
Phenomenon	Troubleshooting
<p>The unit can not operate.</p> 	<ul style="list-style-type: none"> • Has the power been shut down? • Is the power plug loosed? • Is voltage too high or too low? (tested by professional) • Has the TIMER ON function been well operated?
<p>Cooling(Heating) efficiency is not good.</p> 	<ul style="list-style-type: none"> • Is temperature setting suitable? • Does inlet or outlet vents obstructed? • Is filter dirty? • Are the windows and doors closed? • Did fan speed set at low speed? • Is there any heat sources in the room?
<p>Remote control is not available.</p> 	<ul style="list-style-type: none"> • The unit is interfered by abnormal interference or changing function too frequently, wireless remote control can not control occasionally. Plug out power plug and re-insert well could resume normal operation. • Is the control in the receiving area? Or is there obstruction. • Check if the voltage batteries in the control is enough, if not, change batteries.
<p>If water leakage in indoor unit.</p>	<ul style="list-style-type: none"> • The air humidity is on the high side. • Condensing water over flowed. • The indoor unit drainage pipe connection loosed.
<p>If water leakage in outdoor unit.</p>	<ul style="list-style-type: none"> • When the unit is running in COOL mode, the connection of pipe and pipe joint will be condensed due to the water cooled down.
<p>Noise from indoor unit emitted.</p>	<ul style="list-style-type: none"> • Fan or compressor relay switching (On/OFF) sound.
<p>Indoor unit can't deliver air.</p>	<ul style="list-style-type: none"> • In DRY “☁” mode, indoor fan sometimes will stop, in order to avoid condensing water be vaporized again, restrain temperature raising
<p>Moisture on air outlet vent.</p>	<ul style="list-style-type: none"> • If unit is running under the high humidity for a long time, the moisture will be condensed on the air outlet grill and drip off.

7. NOTICES FOR INSTALLATION



Important Notices

1. The unit installation work must be done by qualified personnel according to the local rules and this manual.
2. Before install, please contact with local authorized maintenance center. If the unit is not installed by the authorized maintenance center, the malfunction may not solved, due to discommodious contacts.
3. When removing the unit to the other place, please firstly contact with the authorized SANYO Maintenance Center in the local area.

7.1 Basic Requirements for Installation Position

Install in the following place may cause malfunction. If it is unavoidable contact with service center please:

1. Place where strong heat sources, vapors, flammable gas or volatile object are emitted.
2. Place where high-frequency waves are generated by radio equipment, welders and medical equipment.
3. Place where a lot of salinities such as coast exists.
4. Place where a sulfured gas such as the hot spring zones is generate.
5. Place where the oil (machine oil) is contained in the air.
6. Other place with special circumstance.

7.2 Indoor Unit Installation Position Selection

1. The air inlet and outlet vent should be far from the obstruction, make sure that the air can be blown through the whole room.
2. Select a position where the condensing water can be easily drained out, and the places easily connected for outdoor unit.
3. Select a location where the children can not reach.
4. Can select the place where is strong enough to withstand the full weight and vibration of the unit. And will not increase the noise.
5. Be sure to leave enough space to allow access for routine maintenance. The height of installed location should be 200cm or more from the floor.
6. Select a place about 1m or more away from TVset or any other electric appliances.
7. Select a place where the filter can be easily taken out.
8. Make sure that the indoor unit installation should accord with installation dimension diagram requirements. (Pg.24)

7.3 Outdoor Unit Installation Position Selection

1. Select a location from which noise and outflow air emitted by unit will not inconvenience neighbours, animals, plants.
2. Select a location with sufficient ventilation.
3. Select a location where there should be no obstructions cover the inlet and outlet vent.
4. The location should be able to withstand the full weight and vibration of the outdoor unit and permit safe installation.
5. Select a dry place, but do not expose under the direct sunlight or strong wind.

7. NOTICES FOR INSTALLATION

7.3 Outdoor Unit Installation Position Selection (Continued)

6. Make sure that the outdoor unit installation dimension should accord with installation dimension diagram, convenient for maintenance, repair. (See Pg.21)
7. The height difference of connecting the tubing & the max. length of connecting tubing refer to Pg.31, Table 4.
8. Select a place where it is not reachable for the children.
9. Select a place where will not block the passage and do not influence the city appearance.

7.4 Safety Requirements for Electric Appliances

1. The power supply should be used the rated voltage and AC exclusive circuit, the power cable diameter should be satisfied.
2. Voltage applying range: the normal running range is rated voltage 198V - 264V.
3. Don't drag the power cable emphatically.
4. It should be reliable earthed and it should be connected to the special earth device, the installation work should be operated by the professional.
 - The creepage protect switch and air switch with enough capacity must be installed in the fixing circuit.
 - Air switch (thermal-magnetic breaker) can protect the short circuit and overload.
5. The min. distance from the unit and combustive surface is 1.5m.

- NOTE**
- **The power supply position should be correctly connected, and that should be reliably connected, no internal short circuit.**
 - **Wrong connection, may cause fire.**

7.5 Earthing Requirements

1. Air conditioner is type 1 electric appliance, thus please do conduct reliable earthing measure.
2. The yellow-green two-color wire in air conditioner is earthing wire and cannot be used for other purpose. It cannot be cut off and be fix it by screw, otherwise it would cause electric shock.
3. The user power must offer the reliable earthing terminal. DO NOT connect the earthing wire with the bellow places:
 - Gas pipe
 - Tap water pipe
 - Contamination pipe
 - Other places that the professional personnel consider them unreliable.

7.6 Others

1. The connection method of unit and power cable as well as the interconnection method of each isolated component should refer to the circuit diagram stick on the unit.
2. The model of the blown fuse and rated value should refer to the silk-screen on the controller or fuse sleeve.
3. The outside static pressure is 0MPa when the unit is testing.

8. INSTALLATION DIENSION DIAGRAM

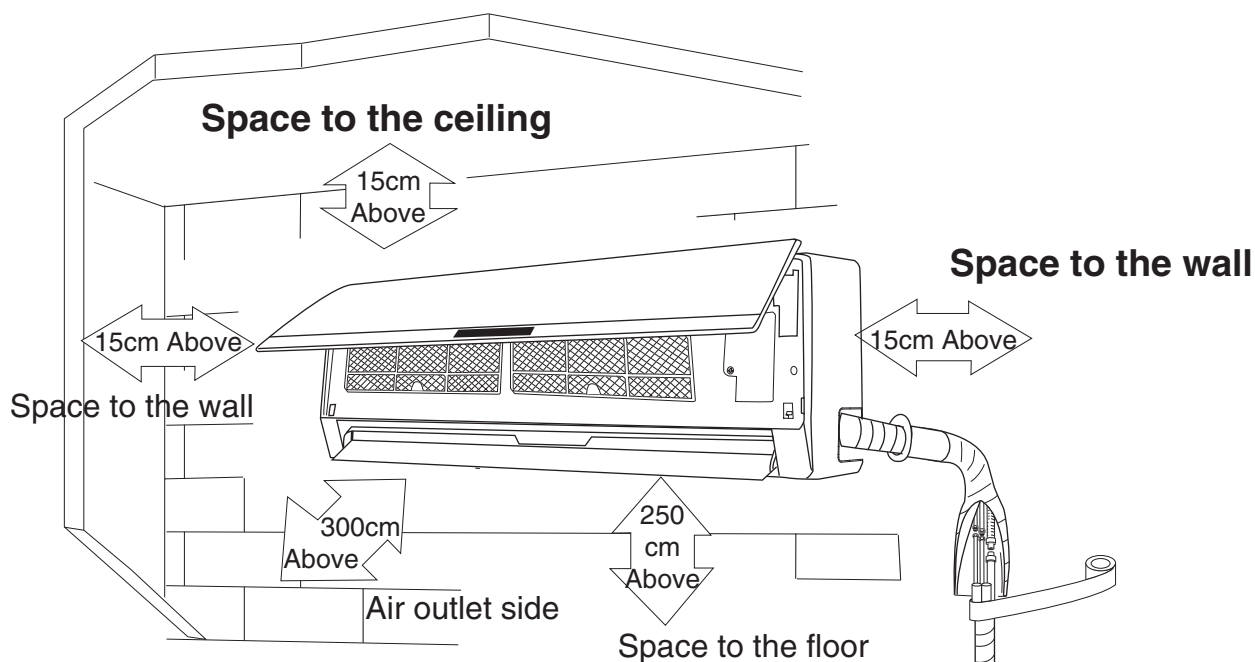

- The dimensions of the space necessary for correct installation of the appliance including the minimum permissible distances to adjacent structures.

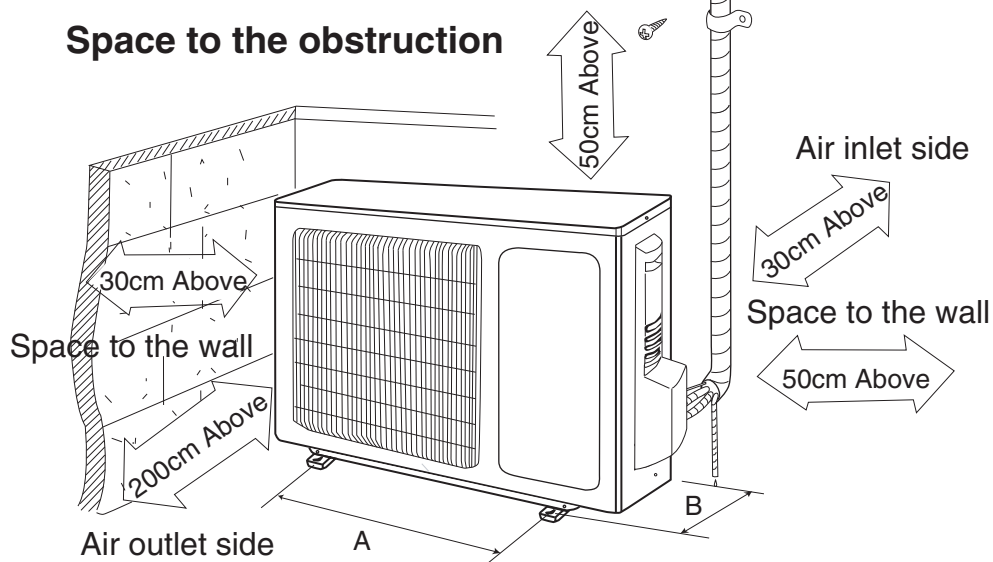

Models	Outdoor Unit Installation Dimension (mm)	
	A	B
SAP-C9AP	440	286
SAP-C12AP	540	286
SAP-C18AP	550	342
SAP-C25AP	560	381
SAP-C30AP	572	378

9. INSTALL INDOOR UNIT

9.1 Install the Rear Panel

1. Always mount the rear panel horizontally.
Due to the water tray of indoor unit has been adopted the both-way drainage design, the outlet of water tray should be adjusted slightly down when installing, that is taking the outlet of the water tray as the center of a circle, the included angle between the evaporator and level should be 0 or more, that is good for condensing water drainage.
2. Fix the rear panel on the wall with screws.
(Where is pre-covered with plastic granula)
3. Be sure that the rear panel has been fixed firmly enough to support the weight of an adult of 60kg, further more, the weight should be evenly shared by each screw.

9.2 Install the Piping Hole

1. Determine which side of the unit you should make the hole for tubing and wiring.
(Fig.11,12)
2. Make the piping hole ($\phi 55$ or $\phi 70$) in the wall at a slight downward slant to the outdoor side.
(Fig.13)

- NOTE**
- Before making the hole, check carefully that no studs or pipes are directly run behind the spot to be cut.
 - Also avoid areas where electrical wiring or conduits are located.

3. Insert the piping-hole sleeve into the hole to prevent the connection piping and wiring from being damaged when passing through the hole.

9.3 Install the Water Drainage Pipe

1. Drainage hose must be placed at downward slant downward slant for smooth drainage.
2. Do not wrench, bend or heave the drainage hose or flood its end by water. (Fig.14)
3. The prolonged drainage hose should be covered by heat insulation material when through indoor.

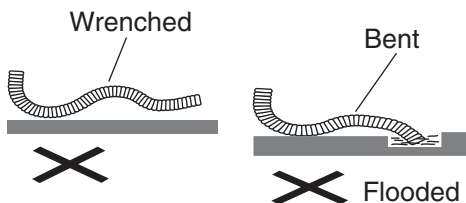
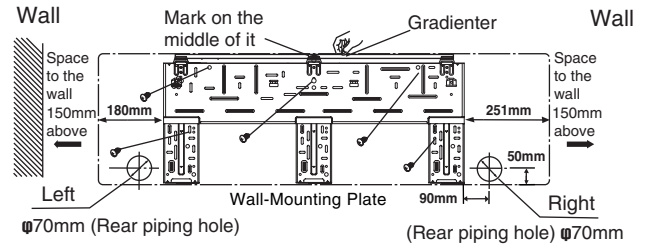
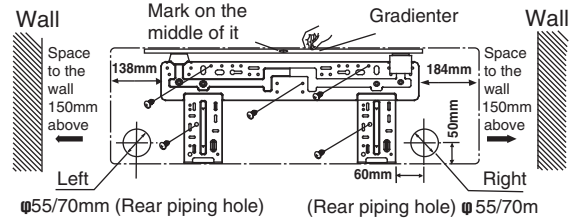

Fig.14

Model: K30AP



Models: K18AP / K25AP



Models: K12AP

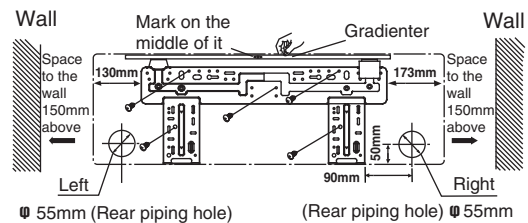

Models: K9AP

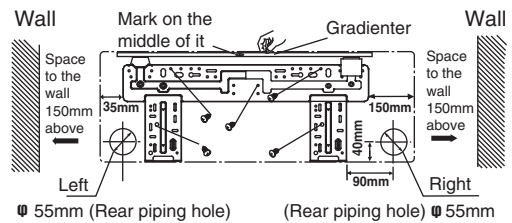

Fig.11

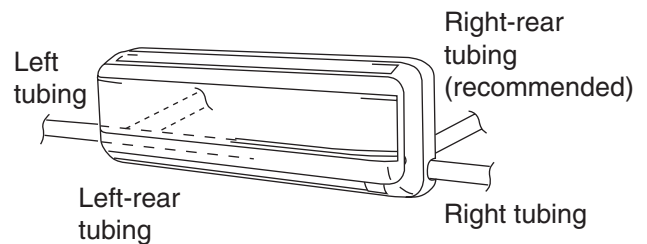
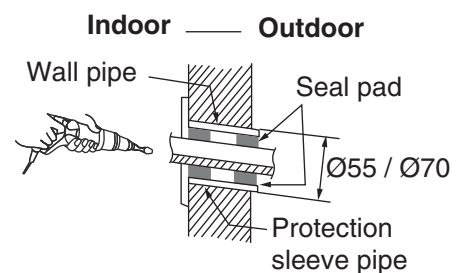

Fig.12



Hole Dia. (K9AP, K12AP K18AP)	Hole Dia. (K25AP, K30AP)
$\phi 55\text{mm}$	$\phi 70\text{mm}$

Fig.13

9. INSTALL INDOOR UNIT

9.4 Connect Indoor and Outdoor Electric Wire

1. The power wire and power connection wire are supplied in factory in a fixed length. (Fig.15,16,17)



WARNING

To avoid the risk of fire hazard, do consult your local dealer if additional wire length is required.

2. Open the surface panel and remove the wiring cover. (Fig.15,16,17)
3. Route the power connection wire from the back of the indoor unit and pull it toward the front through the wiring hole for connection.
4. Connect the interconnection cord to the terminal block, and then fix the cord with wire clamp.
5. Re-assemble the clamp and wiring cover.
6. Re-cover the surface panel.



WARNING

Since one end of power connector wire has been connected in the unit, when testing unit with electrified, the other end of the power connect wire may carry electricity. Please note to prepare well insulation to prevent short circuit or electricity shock.

9.4.1 Wiring Instructions

NOTE General Precautions on Wirings

1. Before wiring, confirm the rated voltage of the unit as shown in nameplate, then carry out the wiring closely follow the wiring diagram.
2. Provide a power outlet to be used exclusively for each unit, with a power supply disconnect and circuit breaker for overcurrent protection provided in the exclusive line.
3. To prevent possible hazard due to insulation failure, the unit must be grounded.
4. Each wiring connection must be done tightly and in accordance with the wiring system diagram. Wrong wiring may cause the unit to misoperate or become damaged.
5. Do not allowed wiring to touch the refrigerant tubing, compressor, or any moving parts of the fan.
6. Unauthorised changes in the internal wiring can be very dangerous. The manufacturer will accept no responsibility for any damage or misoperation that occurs as a result of such unauthorised changes.

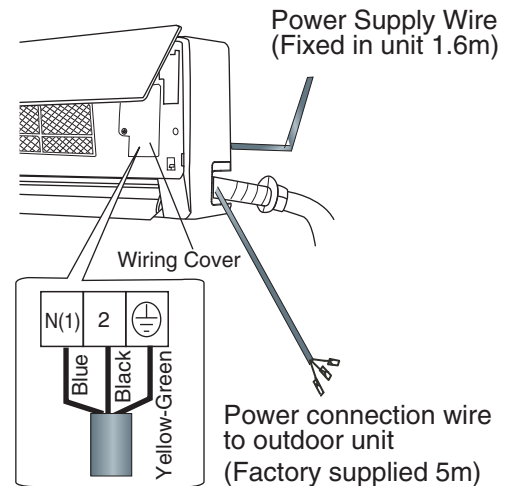

Fig.15 (K9AP, K12AP)

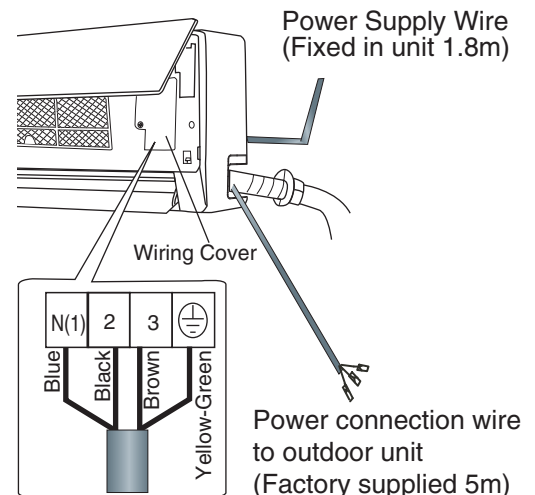

Fig.16 (K18AP, K25AP)

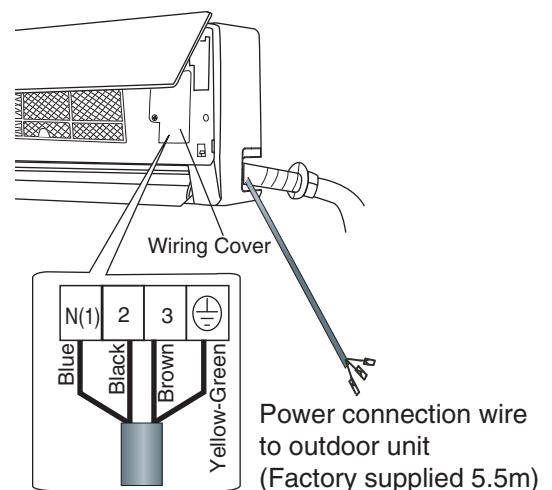

Fig.17 (K30AP)

9. INSTALL INDOOR UNIT

9.4.2 Wire Length and Diameter

Regulations on wiring diameter differ from locality. For field wiring requirements, please refer to local electrical codes. Carefully observe these regulations when carrying out the installation.

Table 1 lists the recommended and max. allowable wire lengths and diameters for the power supply system. Please refer to the wiring system diagram (Fig.18 & 19) for the meaning of "A", "B" in Table 1a,b,c,d.

Table 1a

Cross-sectional area (mm ²)	Recommended		Max. allowed	Fuse or circuit breaker capacity
	*(A)	*(B)	(A) + (B)	
Model	1.0x (3)	1.0x (3)	1.0	
KC9AP	1.6m	5.0m	17m	10A

Table 1b

Cross-sectional area (mm ²)	Recommended		Max. allowed	Fuse or circuit breaker capacity
	*(A)	*(B)	(A) + (B)	
Model	1.5 x (3)	1.5 x (3)	1.5	
KC12AP	1.6m	5.0m	22m	10A

Table 1c

Cross-sectional area (mm ²)	Recommended		Max. allowed	Fuse or Circuit breaker capacity
	*(A)	*(B)	(A) + (B)	
Model	2.5 x (3)	2.5 x (4)	2.5	
KC18AP	1.8m	5.0m	32m	20A
KC25AP	1.8m	5.0m	32m	30A

Table 1d

Cross-sectional area (mm ²)	Recommended		Max. allowed		Fuse or circuit breaker capacity
	*(A)	*(B)	(A)	*(B)	
Model	4.0 x (3)	1.0 x (4)	4.0	1.0 x (4)	
KC30AP	6.0m	5.5m	20m	32m	30A

*(A) Power supply wiring length (m) ; *(B) Power connection wire length (m)



CAUTION

- Be sure to connect the power supply line to the indoor unit as shown in the wiring diagram.
 - (a) Fig.18 (KC9AP, KC12AP, KC18AP, KC25AP)
The outdoor unit draws its power from the indoor unit.
 - (b) Fig.19 (KC30AP)
The indoor unit draws its power from the outdoor unit.



WARNING

- Be sure to comply with local codes on running the wire from the indoor unit to the outdoor unit (size of wire and wiring method, etc.).
- Each wire must be firmly connected.
- No wire should be allowed to touch refrigerant tubing, the compressor, or any moving part.



WARNING

To avoid the risk of electric shock, each air conditioner unit must be grounded.

WIRING SYSTEM DIAGRAM

Models: KC9AP, KC12AP

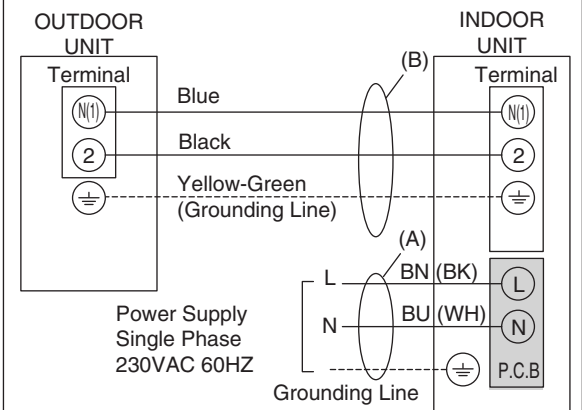

Models: KC18AP, KC25AP

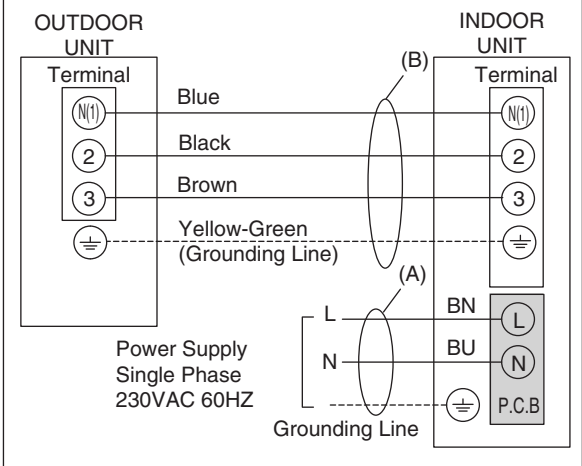

Fig. 18 Outdoor unit draws its power from indoor unit.

Model: KC30AP

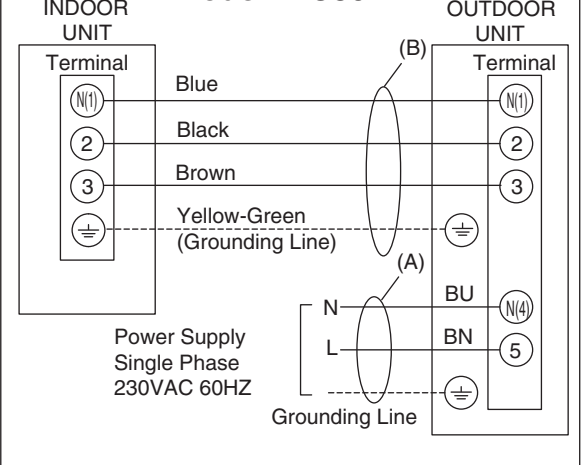

Fig. 19 Indoor unit draws its power from outdoor unit.

9. INSTALL INDOOR UNIT

9.5 How to Install the Indoor Unit

For tubing, choose either the left side or right side direction.

- When routing the piping and wiring from the left or right side of indoor unit, cut off the tailing from the chassis in necessary. (As shown in Fig 20)
 - Cut off the tailings 1 when routing the wiring only.
 - Cut of the tailings 1 and tailings 2 when routing both the wiring and piping.
- Take out the piping from body case, wrap the piping, electric wire, water pipe with tape and push them through the piping hole. (As show in Fig.21)
- Hang the mounting slots of the indoor unit on the upper tabs of the rear panel and check if it is securely seated on the rear panel. (As show in Fig.22)
- Carefully bend the tubing (if necesary) to run along the wall in the direction of outdoor unit and then tape as far as the fittings. (Refer 9.3 on Pg. 22). The drain hose should come staright down the wall to a point where water run off won't stain the wall.
- Connect the refrigerant tubing to the outdoor unit. (After performing a leak test on the connecting part, insulate it with the tubing insulation. (Fig.21) Also, refer to Pg 28, (connecting tubing between indoor and outdoor unit).

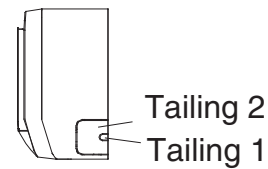

Fig.20

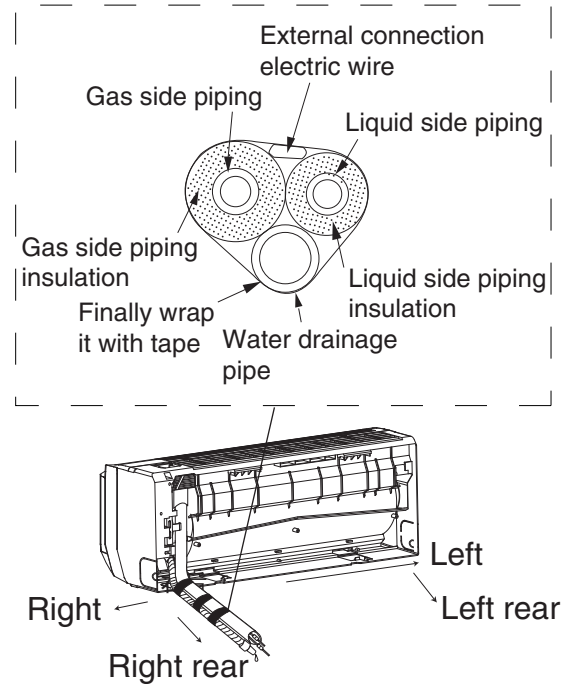

Fig.21

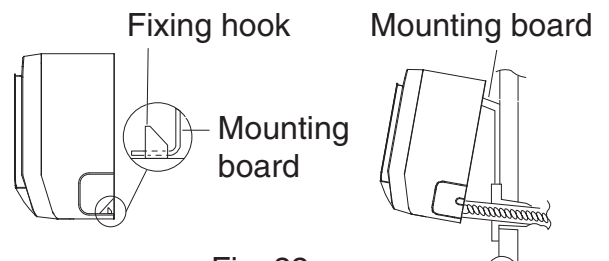

Fig. 22

NOTE For stable operation of the air conditioner, do not install wall-mounted type indoor units less than 2.5m from the floor level. (Fig.23)

! **CAUTION** Do not supply power to unit or operate it until all tubing and wiring to the outside unit are completed.

⚡ **Risk of Electric Shock**

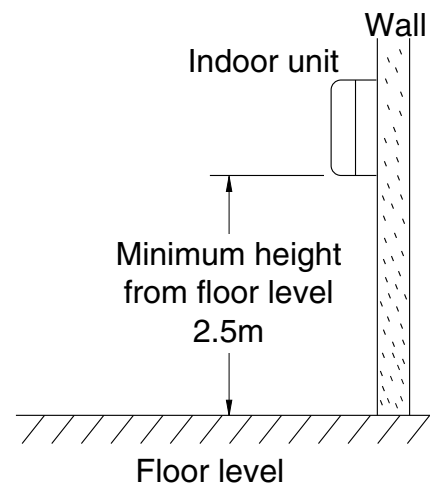

Fig.23

10. INSTALL OUTDOOR UNIT

10.1 Wiring Instructions for the Outdoor Unit

Regulations on wire size differ from locality. For field wiring requirements, please refer to your local electrical codes. Make sure that the installation fully complies with all local and national regulations.

1. C9AP, C12AP, C18AP, C25AP

Disassemble the handle on the outdoor unit right side plate. (Screw x 1pc)

C30AP

Disassemble the front side plate on the outdoor front side. (Screw x 3pcs)

- Take off wire clamp, connect and fix power connect cord to terminal of line bank. **Connect the inter-unit wiring and power line according to the drawing on the handle (C9,12,18,25AP) or front side plate (C30AP).**

NOTE Use the wire clamp to fix the signal control wire, then connect to the corresponding connector.

- Fix the power connection cable with wire clamp. (Fig. 24)
- Be sure to size each wire allowing approx. 10 cm longer than the required length for wiring, Store excess wiring inside the cabinet.
- When connections are completed, check that all connections are correct as shown in the wiring system diagram on the handle / front side plate.
- Be sure to ground the unit according to your local codes.
- Install back the handle / front side plate.

WARNING

Loose wiring may cause the terminal to overheat or result in unit malfunction. A fire hazard may also exist. Therefore, be sure all wiring is tightly connected.

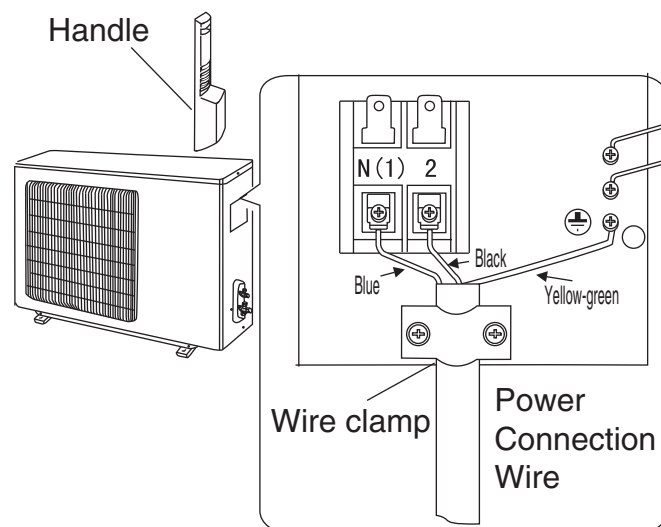

Fig. 24a (C9AP,C12AP)

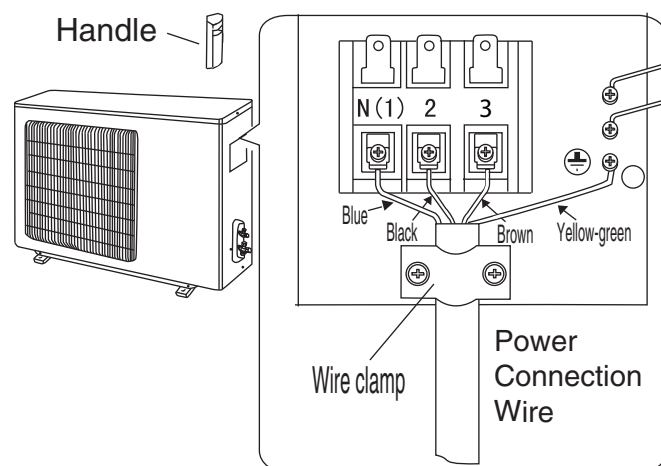

Fig. 24b (C18AP, C25AP)

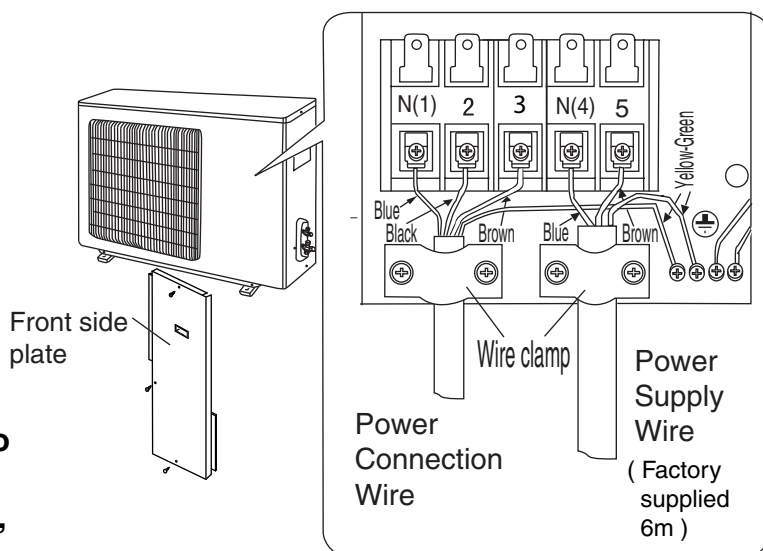

Fig. 24c (C30AP)

10. INSTALL OUTDOOR UNIT

10.2 Refrigerant Tubing

10.2.1 Use of The Flaring Method

Many of the conventional split system air conditioners employ the flaring method to connect refrigerant tubes which run between indoor and outdoor units. In this method, the copper tubes are flared at each end and connected with flare nuts.

10.2.2 Flaring Procedure With A Flare Tool

- Cut the copper tube to the required length with a tube cutter. It is recommended to cut approx. 30 - 50 cm longer than the tubing length you estimate.
- Remove burrs at the end of the copper tube with a reamer or file. This procedure is important and should be done carefully to make a good flare. (Fig.25)

NOTE When reaming, hold the tube end downward and be sure that no copper scraps fall into the tube. (Fig.26)

- Remove the flare nut from the unit and be sure to mount it on the copper tube.
- Make a flare at the end of copper tube with a flare tool.* (Fig.27)
(*Use "GRID" or equivalent.)

NOTE A good flare should have the following characteristics:

- inside surface is glossy and smooth.
- edge is smooth.
- tapered sides are of uniform length.

10.2.3 Caution Before Connecting Tubes Tightly

- Be sure to apply a sealing cap or water-proof tape to prevent dust or water from getting into the tubes before they are used.
- Be sure to apply refrigerant lubricant to the matching surfaces of the flare and union before connecting them together. This is effective for reducing gas leaks. (Fig.28)
- For proper connection, align the union tube and flare tube straight with each other, then screw in the flare nut lightly at first to obtain a smooth match. (Fig.29)

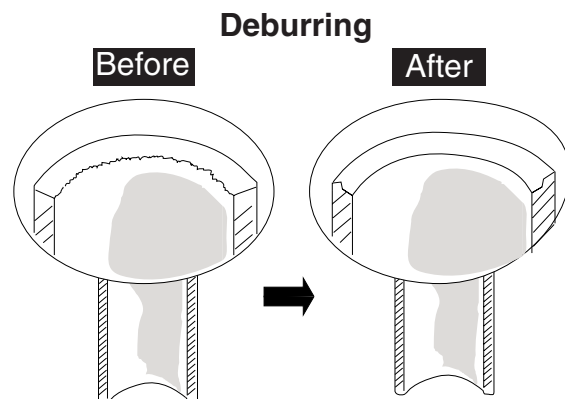

Fig.25

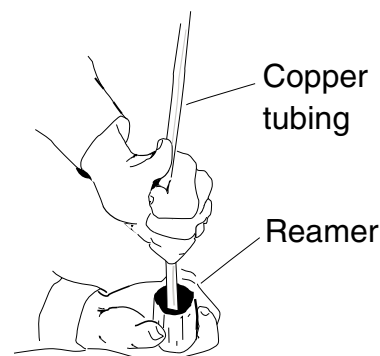

Fig.26

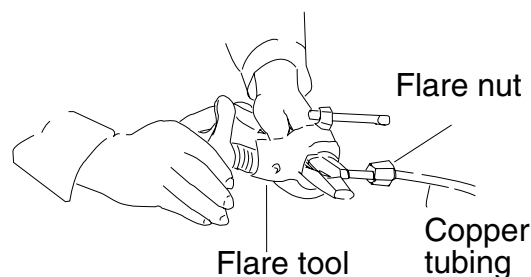

Fig.27

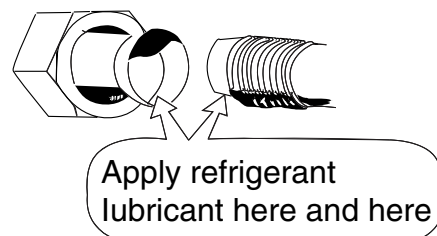
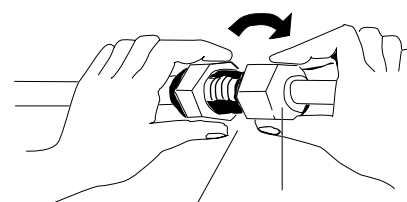

Fig.28



Union Flare nut
Fig.29

10. INSTALL OUTDOOR UNIT

10.2.4 Connecting Tubing between Indoor and Outdoor Units

- Tightly connect the indoor side refrigerant tubing extended from the wall with the outdoor side tubing. (Fig. 30)
- To fasten the flare nuts, apply specified torque as table 2:

Table 2

Tube Dia.	Tightening Torque
6.35 mm	Approx. 15 - 20 N.m (1.5 - 2.0 kg.m)
9.52 mm	Approx. 35 - 40 N.m (3.5 - 4.0 kg.m)
12.7 mm	Approx. 50 - 55 N.m (5.0 - 5.5 kg.m)
15.88 mm	Approx. 68 - 82 N.m (6.8 - 8.2 kg.m)

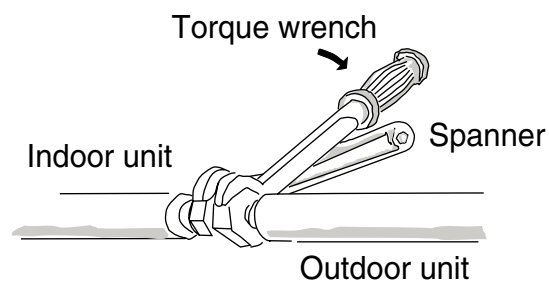

Fig.30

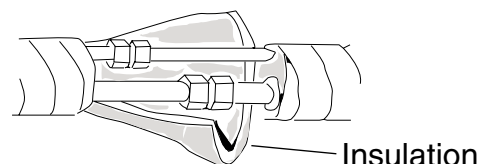

Fig.31

10.2.5 Insulation of Refrigerant Tubing

! IMPORTANT

To prevent heat loss and wet floors due to dripping of condensation, **both tubes must be well insulated with proper insulation material.** The thickness of the insulation should be a min. 8mm. (Fig. 31, 32)

! CAUTION

After a tube has been insulated, never try to bend it into a narrow curve, as this may cause to break or crack.

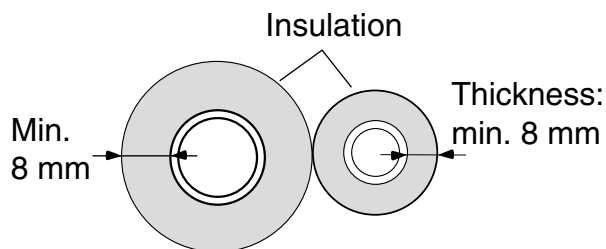

Fig.32

10.2.6 Taping the Tubes

- At this time, the 2 refrigerant tubes (and electrical wire if codes permit) should be taped together with armoring tape. The drain hose may also be taped together as 1 bundle with the tubing.
- Wrap the armoring tape from the bottom of the outdoor to the top of tubing where it enters the wall. As you wrap the tubing, overlap half of each previous tape turn. (Fig. 33)
- Clamp tubing bundle to wall, using 1 clamp approx. every 120cm.

NOTE Do not wind the armoring tape too tightly, since this will decrease the heat insulation effect. Also, be sure the condensation drain hose splits away from the bundle and drips clear of the unit and the tubing.

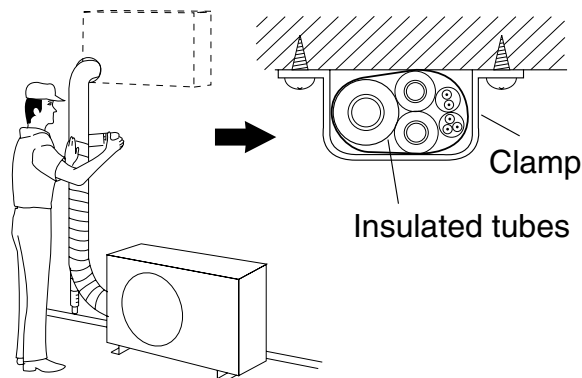

Fig.33

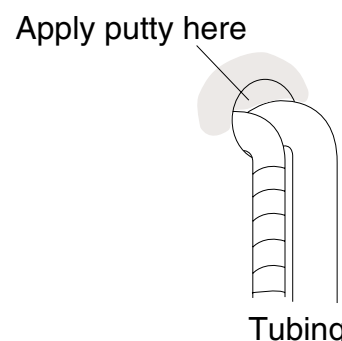

Fig.34

10.2.7 Finish the Installation

After finishing insulating and taping over the tubing, use sealing putty to seal off the hole in the wall to prevent rain and draft from entering. (Fig. 34) shows refrigerant tubing taped separately from the drain hose.

10. INSTALL OUTDOOR UNIT

10.3 Air Purging

Air and moisture remaining in the refrigerant system have undesirable effects as indicated below. Therefore, they must be purged completely.

- Pressure in the system rises
- Operating current rises
- Cooling (or heating) efficiency drops
- Moisture in the air may freeze and block capillary tubing.
- Water may lead to corrosion of parts in the refrigerant system.

AIR PURGING WITH A VACUUM PUMP (FOR TEST RUN)

1. Check that each tube (both narrow and wide tubes) between the indoor and outdoor units have been properly connected and all wiring for the test run has been completed. Note that both narrow and wide tube service valves on the outdoor unit are kept closed at this stage.
2. Using an adjustable wrench or box wrench, remove the valve caps from the service on both narrow and wide tubes.
3. Connect a vacuum pump and a manifold valve (with pressure gauges) to the service port on the wide tube service valve. (Fig.35)

! CAUTION

Be sure to use a manifold valve for air purging. If it is not available, use a stop valve for this purpose. The "Hi" knob of the manifold valve must always be kept closed.

4. With the "Lo" knob of the manifold valve open, run the vacuum pump. The operation time for the vacuum pump varies with tubing length and the capacity of the pump. The following table shows the amount of time for evacuation:

Table 3

Required time for evacuation when capacity of 100 liter/h vacuum pump is used	
If tubing length is less than 7 m	If tubing length is more than 7 m
10 min. or more	15 min. or more

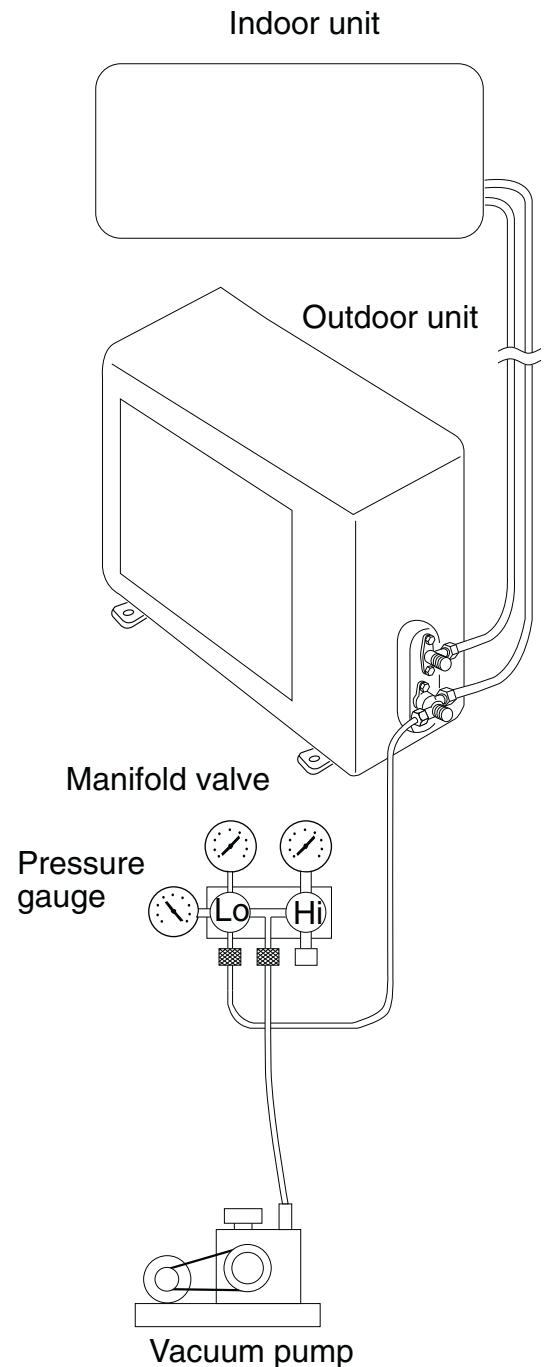

Fig.35

NOTE The require time in the table 3 is calculated based on the assumption that the ideal (or target) vacuum condition is around 10 mmHg abs.

10. INSTALL OUTDOOR UNIT

10.3 Air Purging - (Continued)

5. With the vacuum pump still running, close the "Low" knob of the manifold valve. Then stop the vacuum pump.
6. With the accessory hex wrench, turn the valve stem on the narrow tube service valve counter-clockwise by 90 degrees (1/4 turn) for 10 seconds, and then turn the stem clockwise to close it again. (Fig.36)



CAUTION

Be sure completely insert the hex wrench before attempting to turn the valve.

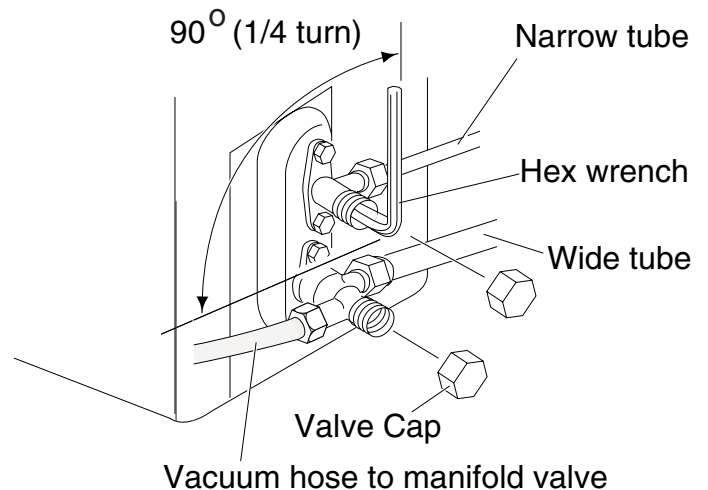

Fig. 36

7. Leak test all joints at tubing (both indoor and outdoor) with liquid soap. Bubbles indicate a leak. Be sure to wipe off the soap with a clean cloth.
8. With the hex wrench, turn the wide tube service valve stem counter-clockwise to fully open the valve.
9. Turn the narrow tube service valve stem counter-clockwise to fully open the valve.
10. Loosen the vacuum hose connected to the wide tube service port slightly to release the pressure. Then, remove the hose.



CAUTION

This may cause the refrigerant gas to leak. In order to avoid this, take off the hose quickly.

11. Fasten the valve cap on the wide tube service port securely with an adjustable wrench or box wrench. Next, mount the valve cap on the service valve and tightened it to 200 kg-cm with a torque wrench. This process is very important to prevent gas leaking from the system.
12. Test run the air conditioner. (See page 33)
13. While the air conditioner is running, apply liquid soap to check for any gas leaks around the service valves or caps.
14. If there is no leakage, stop the air conditioner.
15. Wipe off the soap on the tubing.

This completes air purging with a vacuum pump and the air conditioner is ready for actual operation.

10. INSTALL OUTDOOR UNIT

10.4 Tubing Length

Install unit within the maximum elevation different (H) above or below the outdoor unit and within a total tubing length (L) from the outdoor unit as detailed showed in Table 4 and Fig.37.

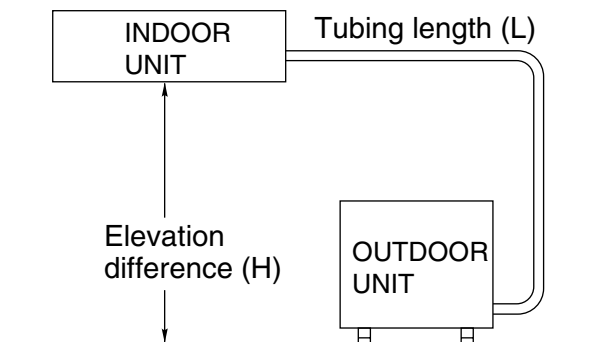

Fig. 37

Table 4

Model	Max. Allowable Tubing Length at Shipment (m)* ¹	Limit of Tubing Length (L) (m)	Limit of Elevation Different (H) (m)	Required Amount of Additional Refrigerant (g/m)* ²
C9AP	5.0	15	5	20
C12AP	5.0	20	5	20
C18AP	5.0	25	7	30
C25AP	5.0	30	7	30
C30AP	5.0	30	15	50

*1 Standard tubing length is 5.0m.

*2 If total tubing length becomes 5.0m to 20 or 25 or 30m, charge additional refrigerant (R22) according to table 4 above. No additional charge of compressor oil is necessary.

10.5 Accessories

Table 5 listed the accessories supplied with the unit.

Table 5

Parts	Figure	Q'ty	Parts	Figure	Q'ty
Power Connection Wire		1	AAA alkaline battery		2
Tapping Screw	Model: K9AP, K12AP 4.2 x 25 mm	5	Flare Nut	 *(K9AP, K12AP only)	1
	Models: K18AP, K25AP, K30AP	10	Remote Control Unit		1
Ins. Tube		1	Putty		1
Power Supply Wire	 *(K30AP only)	1	Remote Control Holder (Optional)		1

*Only for specified model.

11. PUMP DOWN

11.1 What is Pump Down?

Pump down means collecting all refrigerant gas in system back into the outdoor unit without losing any of gas. Pump down is used when the unit is to be moved or before serving the refrigerant circuit.

11.2 Pump Down Procedure

NOTE Be sure to carry out pump down with the unit in cooling mode.

1. Connect the Lo side charging hose of the manifold valve to the service port on the wide tube service valve. (Fig 39)
2. Using a hex wrench, turn the narrow tube service valve clockwise all the way to close the service valve (Fig 40). (Be sure to confirm that the wide tube service valve is fully open.)
3. Press the ON / OFF button and start cooling operation.
4. When the low pressure gauge reading falls from 1 to 0.5 kg/cm², fully close the wide tube valve stem (Fig 41). Then quickly stop the unit.
5. Disconnect all gauges and hoses, and replace the valve caps as they were before.

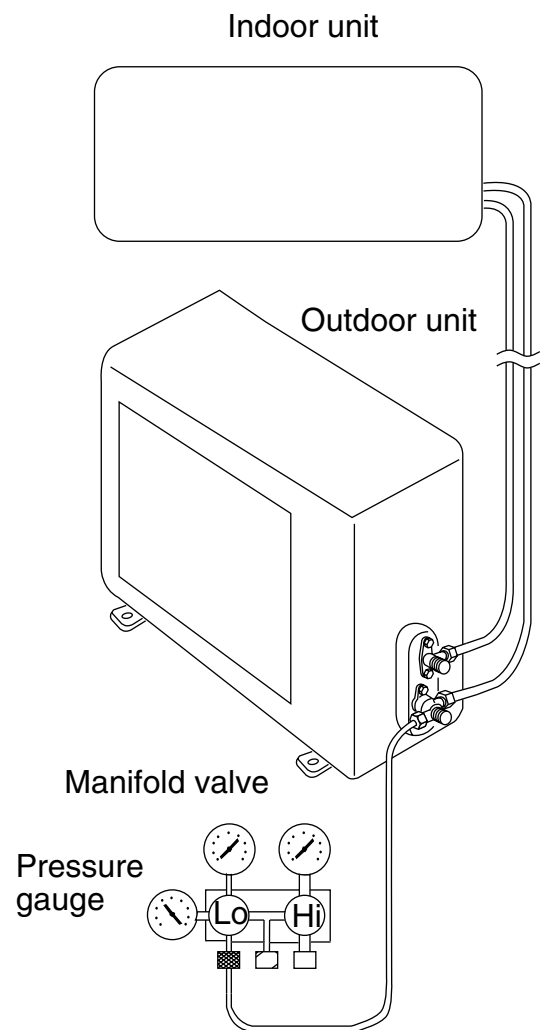

Fig. 39

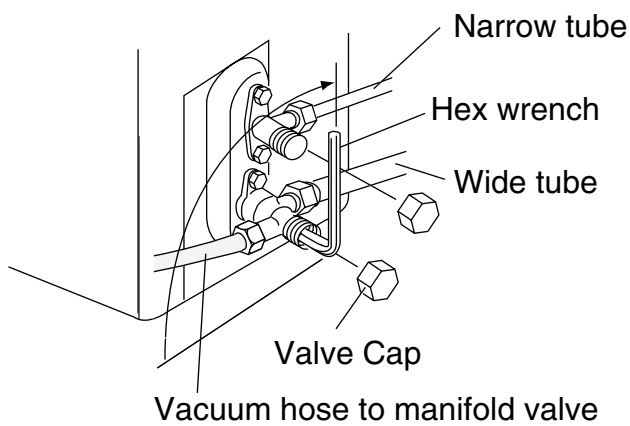

Fig. 41

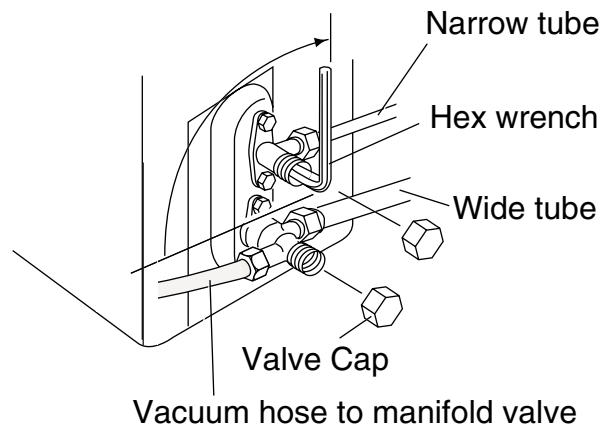

Fig. 40

12. CHECK AFTER INSTALLATION AND TEST RUN

12.1 Check After Installation

Check the items listed in below table after installation of air conditioner.

Items to be checked	Possible malfunction
• Has it been fixed firmly?	• The unit may drop, shake or emit noise.
• Have you done the refrigerant leakage test?	• It may cause insufficient of cooling capacity.
• Is heat insulation sufficient?	• It may cause condensation and dripping.
• Is water drainage well?	• It may cause condensation and dripping
• Is the voltage in accordance with the rated voltage marked on the nameplate?	• It may cause electric malfunction or damage the part.
• Is the electric wiring and piping connection installed correctly and securely?	• It may cause electrical leakage.
• Has the unit been connected to a secure earth connection?	• It may cause electric malfunction or damage the part
• Is the power cord specified?	• It may cause electric malfunction or damage the part
• Is the inlet and outlet been covered?	• It may cause of insufficient cooling capacity.
• Has the length of connection pipes and refrigerant capacity been recorded?	• The refrigerant capacity is not accurate.

12.2 Test Operation

12.2.1 Before Test Operation

- Do not switch on power before installation is finished completely
- Electric wiring must be connected correctly and securely.
- Cut-off valves of the connection pipes should be opened.
- All the impurities such as scraps and thrums must be cleared from the unit.

12.2.2 Test Operation Method

- Switch on power, press "ON / OFF" button on the wireless remote controller to start the operation.
- Press MODE button, to select the "COOL", "FAN" mode to check whether the operation is normal or not.

13. SELF DIAGNOSIS FUNCTION

13.1 What is self diagnosis function?

When the problem detected in the air conditioner, the operation stops and LED indicator lamps on the indoor unit will display the error code (Fig. 42).

Kindly refer Table 6a,b for the meanings of error code and indications for each models.

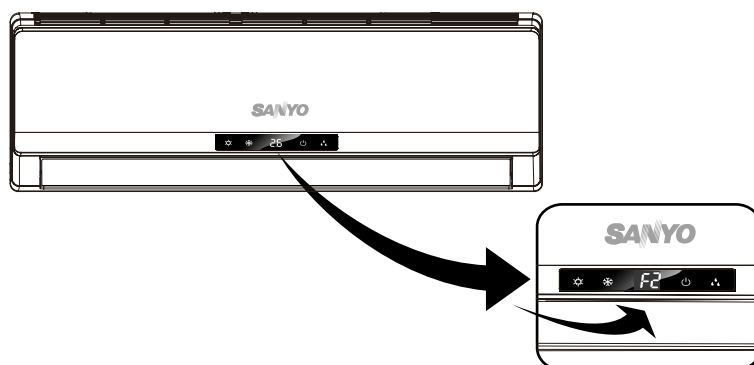

Fig. 42

Table 6a

Error Code (Indoor)	Diagnostics Item	Diagnostics contents	Models
F1	Indoor room temperature sensor.	<ul style="list-style-type: none"> • Sensor opens circuit or short circuit. • Contact failure at connector. • Indoor P.C.B failure. 	K9AP, K12AP, K18AP, K25AP, K30AP.
F2	Indoor heat exchanger coil sensor.		
C5	OTP data (Jumper Cap).	<ul style="list-style-type: none"> • Jumper Cap on P.C.B failure. • Indoor P.C.B failure. 	
H6	Indoor fan motor lock current.	<ul style="list-style-type: none"> • Indoor fan motor failure. If motor running speed is too slow / stop for 1 min., in order to prevent motor self-protection activated, it will stop running and display lock. • Contact failure at connector. 	K9AP, K12AP, K18AP, K25AP.
E5	Overload current protection.	<ul style="list-style-type: none"> • Indoor P.C.B overload current protector activated. 	K18AP, K25AP.
F3	Outdoor temperature sensor.	<ul style="list-style-type: none"> • Outdoor dummy Sensor (R1) failure. • Indoor / outdoor P.C.B failure. 	K30AP only
F4	Outdoor heat exchanger sensor.	<ul style="list-style-type: none"> • Outdoor dummy Sensor (R 2) failure. • Indoor / outdoor P.C.B failure. 	K30AP only

Table 6b. – ONLY for KC30AP.

Error Code (Indoor)	Diagnostics Item	LED (Outdoor)	Diagnostics Contents
E1	High pressure protection.	Outdoor P.C.B LED 1 blinking.	<ul style="list-style-type: none"> • High-pressure switch sensor activated / failure.
E5	Overload current protection.	Outdoor P.C.B LED 2 blinking.	<ul style="list-style-type: none"> • Outdoor P.C.B overload current protector activated.
E6	Communication signal between indoor & outdoor unit failure .	Outdoor P.C.B LED 1, 2, 3 blinking.	<ul style="list-style-type: none"> • Indoor / Outdoor P.C.B failure. • Wrong wirings connection. • Wirings contact failure.
-	Communications signal between Indoor & outdoor unit normal .	Outdoor P.C.B LED 4, 5 blink alternately.	<ul style="list-style-type: none"> • It shows that the communication signal is correctly under this condition.



SANYO Electric Co.,Ltd