

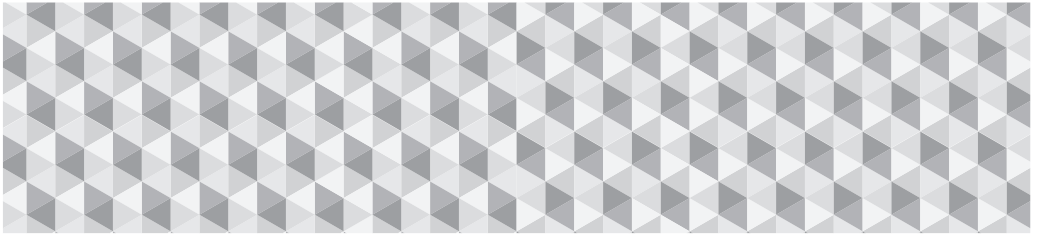

HT-J5550K

User manual

5.1CH Blu-ray™ Home Entertainment System



imagine the possibilities

Thank you for purchasing this Samsung product.

To receive more complete service, please register your product at

www.samsung.com/register

Safety Information

CAUTION

RISK OF ELECTRIC SHOCK. DO NOT OPEN

CAUTION: TO REDUCE THE RISK OF ELECTRIC SHOCK, DO NOT REMOVE THE COVER (OR BACK). THERE ARE NO USER SERVICEABLE PARTS INSIDE. REFER ALL SERVICING TO QUALIFIED PERSONNEL.



This symbol indicates that high voltage is present inside. It is dangerous to make any kind of contact with any internal part of this product.



This symbol indicates that important literature concerning operation and maintenance has been included with this product.

- The slots and openings in the cabinet and in the back or bottom are provided for necessary ventilation. To ensure reliable operation of this apparatus, and to protect it from overheating, these slots and openings must never be blocked or covered.
 - Do not place this apparatus in a confined space, such as a bookcase, or built-in cabinet, unless proper ventilation is provided.
 - Do not place this apparatus near or over a radiator or heat register, or where it is exposed to direct sunlight.
 - Do not place vessels (vases etc.) containing water on this apparatus. A water spill can cause a fire or electric shock.
- Do not expose this apparatus to rain or place it near water (near a bathtub, washbowl, kitchen sink, or laundry tub, in a wet basement, or near a swimming pool, etc.). If this apparatus accidentally gets wet, unplug it and contact an authorized dealer immediately.
- This apparatus uses batteries. In your community, there might be environmental regulations that require you to dispose of these batteries properly. Please contact your local authorities for disposal or recycling information.
- Do not overload wall outlets, extension cords or adaptors beyond their capacity, since this can result in fire or electric shock.
- Route power-supply cords so that they are not likely to be walked on or pinched by items placed on or against them. Pay particular attention to cords at the plug end, at wall outlets, and the point where they exit from the apparatus.
- To protect this apparatus from a lightning storm, or when it is left unattended and unused for long periods of time, unplug it from the wall outlet and disconnect the antenna or cable system. This will prevent damage to the set due to lightning and power line surges.
- Before connecting the AC power cord to the DC adaptor outlet, make sure the voltage designation of the DC adaptor corresponds to the local electrical supply.
- Never insert anything metallic into the open parts of this apparatus. Doing so may create a danger of electric shock.
- To avoid electric shock, never touch the inside of this apparatus. Only a qualified technician should open this apparatus.
- Make sure to plug the power cord in until it is firmly seated. When unplugging the power cord from a wall outlet, always pull on the power cord's plug. Never unplug by pulling on the power cord. Do not touch the power cord with wet hands.
- If this apparatus does not operate normally - in particular, if there are any unusual sounds or smells coming from it - unplug it immediately and contact an authorized dealer or service center.
- Maintenance of Cabinet.
 - Before connecting other components to this product, be sure to turn them off.
 - If you move your product suddenly from a cold place to a warm place, condensation may occur on the operating parts and lens and cause abnormal disc playback. If this occurs, unplug the product, wait for two hours, and then connect the plug to the power outlet. Then, insert the disc, and try to play back again.
- Be sure to pull the power plug out of the outlet if the product is to remain unused or if you are leaving the house for an extended period of time (especially when children, elderly, or disabled people will be left alone in the house).
 - Accumulated dust can cause an electric shock, an electric leakage, or a fire by causing the power cord to generate sparks and heat or the insulation to deteriorate.
- Contact an authorized service center for information if you intend to install your product in a location with heavy dust, high or low temperatures, high humidity, chemical substances, or where it will operate 24 hours a day such as in an airport, a train station, etc. Failing to do so may lead to serious damage of your product.
- Use only a properly grounded plug and wall outlet.
 - An improper ground may cause electric shock or equipment damage. (Class I Equipment only.)
- To turn this apparatus off completely, you must disconnect it from the wall outlet. Consequently, the wall outlet and power plug must be readily accessible at all times.

- Do not allow children to hang on the product.
- Store the accessories (battery, etc.) in a location safely out of the reach of children.
- Do not install the product in an unstable location such as a shaky self, a slanted floor, or a location exposed to vibration.
- Do not drop or strike the product. If the product is damaged, disconnect the power cord and contact a service center.
- To clean this apparatus, unplug the power cord from the wall outlet and wipe the product using a soft, dry cloth. Do not use any chemicals such as wax, benzene, alcohol, thinners, insecticide, air fresheners, lubricants, or detergent. These chemicals can damage the appearance of the product or erase the printing on the product.
- Do not expose this apparatus to dripping or splashing. Do not put objects filled with liquids, such as vases on the apparatus.
- Do not dispose of batteries in a fire.
- Do not plug multiple electric devices into the same wall socket. Overloading a socket can cause it to overheat, resulting in a fire.
- There is danger of an explosion if you replace the batteries used in the remote with the wrong type of battery. Replace only with the same or equivalent type.

WARNING :

- TO PREVENT THE SPREAD OF FIRE, KEEP CANDLES AND OTHER ITEMS WITH OPEN FLAMES AWAY FROM THIS PRODUCT AT ALL TIMES.
- To reduce the risk of fire or electric shock, do not expose this appliance to rain or moisture.



CLASS 1 LASER PRODUCT

This product is classified as a CLASS 1 LASER product. Use of controls, adjustments or performance of procedures other than those specified herein may result in hazardous radiation exposure.

Complies with 21CFR 1040.10 except for deviations pursuant to Laser Notice No. 50, dated June 24, 2007.

CAUTION :

- INVISIBLE LASER RADIATION WHEN OPEN AND INTERLOCKS DEFEATED, AVOID EXPOSURE TO BEAM.

CLASS 1 LASER PRODUCT
KLASSE 1 LASER PRODUKT
LUOKAN 1 LASER LAITE
CLASS 1 LASER APPARAT
PRODUCTO LASER CLASE 1

3D Precautions

IMPORTANT HEALTH AND SAFETY INFORMATION FOR 3D PICTURES.

Read and understand the following safety information before using the 3D function.

- Some viewers may experience discomfort while viewing 3D TV such as dizziness, nausea, and headaches. If you experience any such symptom, stop viewing 3D TV, remove the 3D Active Glasses, and rest.
- Watching 3D images for an extended period of time may cause eye strain. If you feel eye strain, stop viewing 3D TV, remove your 3D Active Glasses, and rest.
- A responsible adult should frequently check on children who are using the 3D function. If there are any reports of tired eyes, headaches, dizziness, or nausea, have the child stop viewing 3D TV and rest.
- Do not use the 3D Active Glasses for other purposes (such as general eyeglasses, sunglasses, protective goggles, etc.)
- Do not use the 3D function or 3D Active Glasses while walking or moving around. Using the 3D function or 3D Active Glasses while moving around may cause you to bump into objects, trip, and/or fall, and cause serious injury.
- If you want to enjoy 3D content, connect a 3D device (3D compliant AV receiver or TV) to the product's HDMI OUT port using a high-speed HDMI cable. Put on 3D glasses before playing the 3D content.
- The product outputs 3D signals only through an HDMI cable connected to the HDMI OUT port.
- The video resolution in 3D play mode is limited to the resolution of the original 3D video. You cannot change the resolution to your preference.
- Some functions such as BD Wise, screen size adjustment, and resolution adjustment may not operate properly in 3D play mode.
- You must use a high-speed HDMI cable for proper output of the 3D signal.
- Stay at least three times the width of the screen from the TV when watching 3D images. For example, if you have a 46 inch screen, stay 3.5 meters from the screen.
- Place the 3D video screen at eye level for the best 3D picture.
- When the product is connected to some 3D devices, the 3D effect may not function properly.
- This product does not convert 2D content into 3D.
- "Blu-ray 3D" and "Blu-ray 3D" logo are trademarks of the Blu-ray Disc Association.

Contents

GETTING STARTED

- 5 Accessories
- 5 Speaker Components
- 6 Front Panel
- 6 Rear Panel
- 7 Remote Control

CONNECTIONS

- 8 Connecting the Speakers
- 11 Connecting to a TV and External Devices
- 12 Connecting to a Network Router

SETTINGS

- 13 The Initial Settings Procedure
- 14 The Home Screen at a Glance
- 14 Accessing the Settings Screen
- 15 Settings Menu Functions
- 18 Radio Setup
- 19 Network Setup
- 22 Wi-Fi Direct
- 23 Upgrading Software
- 24 Setting Up DLNA

PLAYING CONTENT

- 25 Switching the Source Device
- 25 Playing Commercial Discs
- 25 Playing a Disc with User Recorded Content
- 26 Playing Files on a USB Device
- 27 Controlling Video Playback
- 29 Playing a Pre-Recorded Commercial Audio Disc
- 29 Controlling Music Playback
- 31 Playing Photo Content
- 31 Using Karaoke
- 32 Using Bluetooth
- 33 Using the Special Effects Remote Control Buttons

NETWORK SERVICES

- 35 Using BD-LIVE™
- 35 Using DLNA
- 35 Apps
- 36 Using Opera TV Store
- 37 Screen Mirroring

APPENDIX

- 38 Additional Information
- 39 Disk and Format Compatibility
- 44 Troubleshooting
- 47 Specifications
- 48 Licenses

▪ Figures and illustrations in this User Manual are provided for reference only and may differ from actual product appearance.

Getting Started









Check the box for the accessories and speaker components listed or shown below.

Accessories

- Remote Control
- User Manual
- Batteries (AAA size)

		
Power Cable	FM Antenna	HDMI Cable

Speaker Components

				
			Screw (5x15) x 4	
		Center		Speaker Cable x 6
				
Front x 2	Stand x 4	Stand Base x 4	Surround x 2	Subwoofer

Getting Started

Front Panel

DISPLAY ICONS

	FUNCTION		STOP		PLAY/PAUSE
	OPEN/ CLOSE		VOLUME CONTROL		POWER

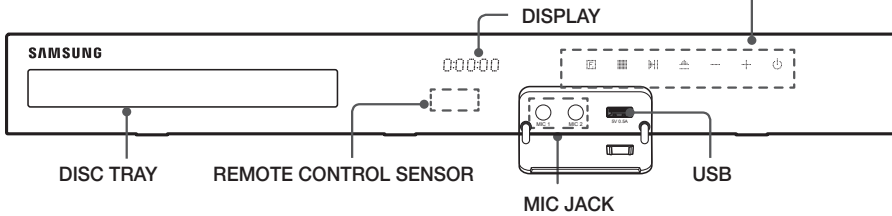

- When the product is on, do not let children touch the product's surface. It will be hot.
- To upgrade the product's software through the USB jack, you must use a USB flash drive.
- When the product displays a Blu-ray Disc menu, you cannot start the movie by pressing the button on the product or the remote. To play the movie, you must select Play Movie or Start in the disc menu, and then press the button.
- If you are using the Internet or are playing content from a USB device on your TV through the home theater, you cannot select the **BD/DVD** mode with the **FUNCTION** button. To select the **BD/DVD** mode, exit the Internet or stop the content you are playing on the TV, and then select the **BD/DVD** mode.
- Plug the microphone jack before using Karaoke function.

Rear Panel

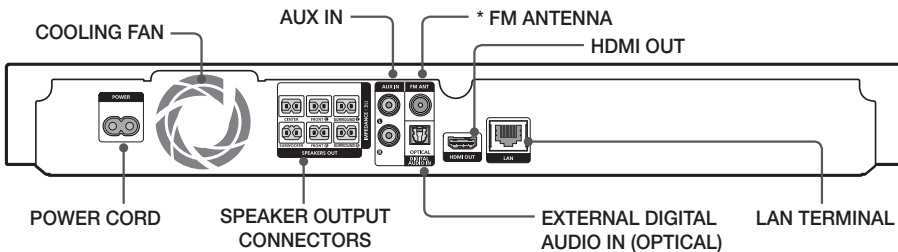

* Connecting the FM Antenna



1. Connect the supplied FM antenna to the FM ANT Jack.
 2. Slowly move the antenna wire around until you find a location where reception is good, then fasten it to a wall or other rigid surface.
- Maintain a minimum of 10 cm of clear space on all sides of the home theater to ensure adequate ventilation. Do not obstruct the cooling fan or ventilation holes.
 - This product does not receive AM broadcasts.

Remote Control

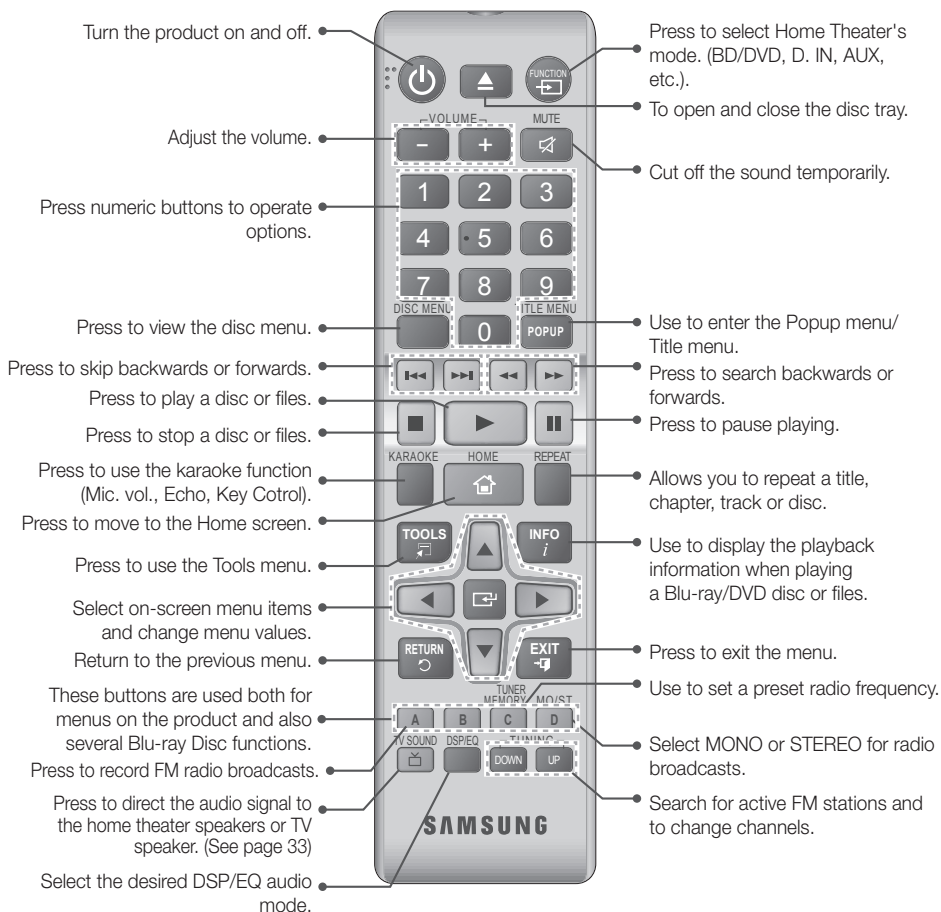
Tour of the Remote Control



Installing batteries in the Remote Control

-  Make sure to match the "+" and "-" ends of the batteries with the diagram inside the compartment.
-  Assuming typical usage, the batteries last for about one year.
-  The remote control can be used up to approximately 7 meters from the product in a straight line.

Battery size: AAA

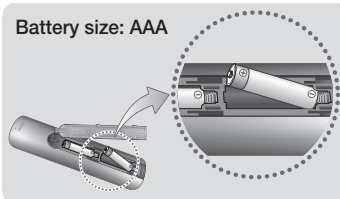

Connections

This section describes various methods of connecting the product to other external components. Before moving or installing the product, be sure to turn off the power and disconnect the power cord.

Connecting the Speakers

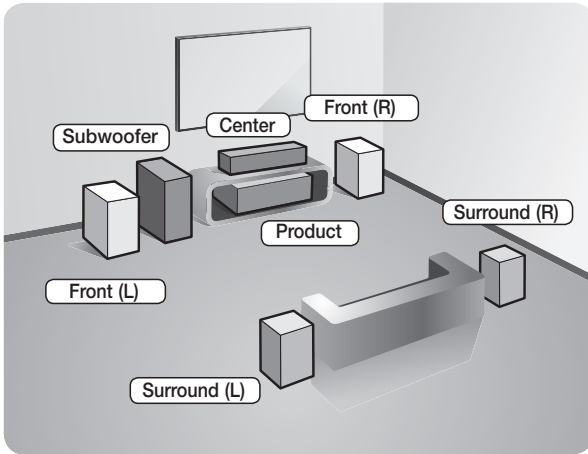

Position of the product

Place it on a stand or cabinet shelf, or under the TV stand.

Selecting the Listening Position

The listening position should be located about 2.5 to 3 times the TV's screen size away from the TV. For example, if you have a 46 inch screen, locate the listening position 2.92 to 3.50 meters from the screen.

Front Speakers	Place these speakers in front of your listening position, facing inwards (about 45°) toward you. Place the front speakers so that their tweeters will be at the same height as your ear. Align the front face of the front speakers with the front face of the center speaker or place them slightly in front of the center speakers.
Center Speaker	It is best to install the center speaker at the same height as the front speakers. You can also install it directly over or under the TV.
Surround Speakers	Place these speakers to the side of your listening position. If there isn't enough room, place these speakers so they face each other. Position them about 60 to 90cm above your ear, facing slightly downward. * Unlike the front and center speakers, the surround speakers are used mainly for sound effects. Sound will not come from them all the time.
Subwoofer	The position of the subwoofer is not so critical. Place it anywhere you like.

* The appearance of your speakers may differ from the illustrations in this manual.

* Each speaker has a colored label on its back or underside. Each cable has a single colored band near its end. Match the band on each cable to the speaker label by color, and then connect the cable to the speaker. See page 9 for exact instructions.

Installing the Speakers on the Tallboy Stand

1. Turn the Stand Base upside-down and connect it to the Stand.
2. Use the driver to fasten the screws (5x20) on the 4 marked holes.

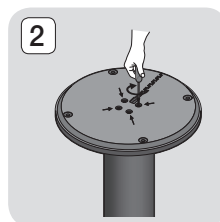
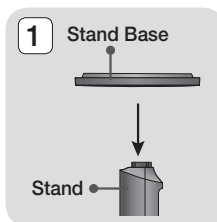

3. Straighten the provided speaker cable and run it through the center hole of the Stand Base. Pull the cable out from the hole of the stand pole.
4. Connect the upper Speaker to the assembled Stand.

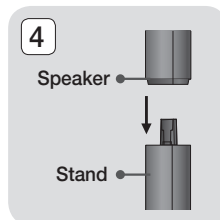
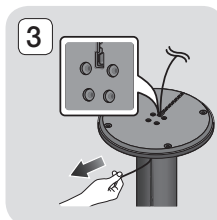

5. Insert a screw (5x15) and fasten it lockwise through the hole on the rear of the speaker using a screwdriver.
6. Arrange the speaker cable along the groove on the rear side of the stand pole.

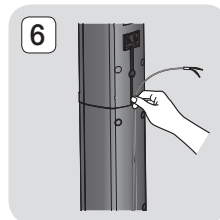
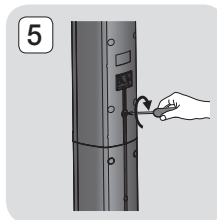

7. Connect the arranged speaker cables to the port on the speaker's rear side while matching their colors.
8. This is the appearance after the speaker is installed. Follow this steps to install other speaker.

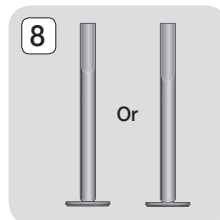
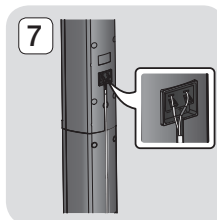

Speaker Cable Connections

1. Match each speaker cable bundle to the correct speaker by matching the colored band on each bundle to the colored sticker on the bottom or back of each speaker.
2. Connect the speaker wire plugs from each speaker to the back of the product by matching the colored band on each cable to the colors of the speaker jacks. When connecting, make sure to match label color on the back of speaker.

Connections

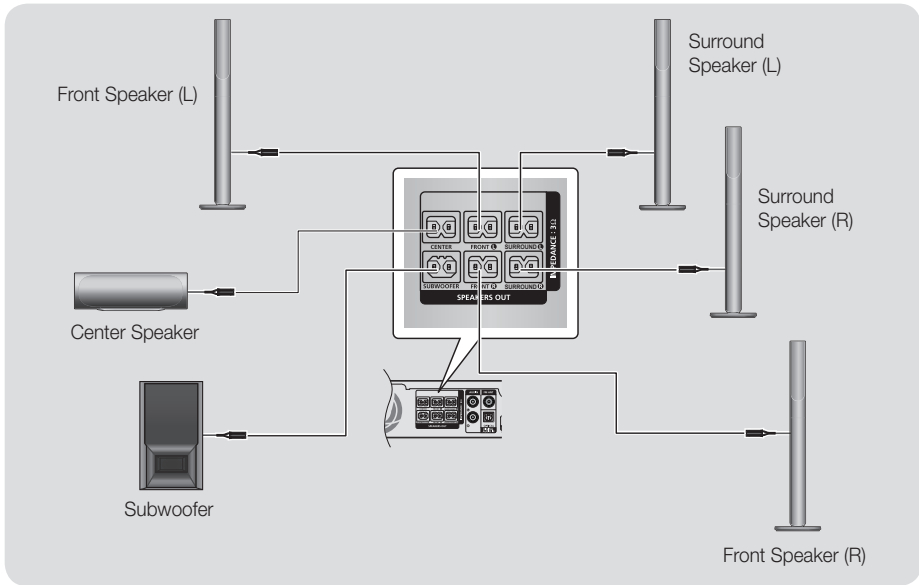

🔗 If you place a speaker near your TV set, the screen color may be distorted because of the magnetic field.

| CAUTION |

- ▶ If you want to install the speakers on the wall, fasten screws or nails (not provided) firmly to the wall wherever you want to hang a speaker, and then, using the hole in the rear of each speaker, carefully hang each speaker on a screw or nail.
- ▶ Do not let children play with or near the speakers. They could get hurt if a speaker falls.
- ▶ When connecting the speaker wires to the speakers, make sure that the polarity (+/-) is correct.
- ▶ Keep the subwoofer speaker out of reach of children to prevent children from inserting their hands or alien substances into the duct (hole) of the subwoofer speaker.
- ▶ Do not hang the subwoofer on the wall by the duct (hole).

Connecting to a TV and External Devices

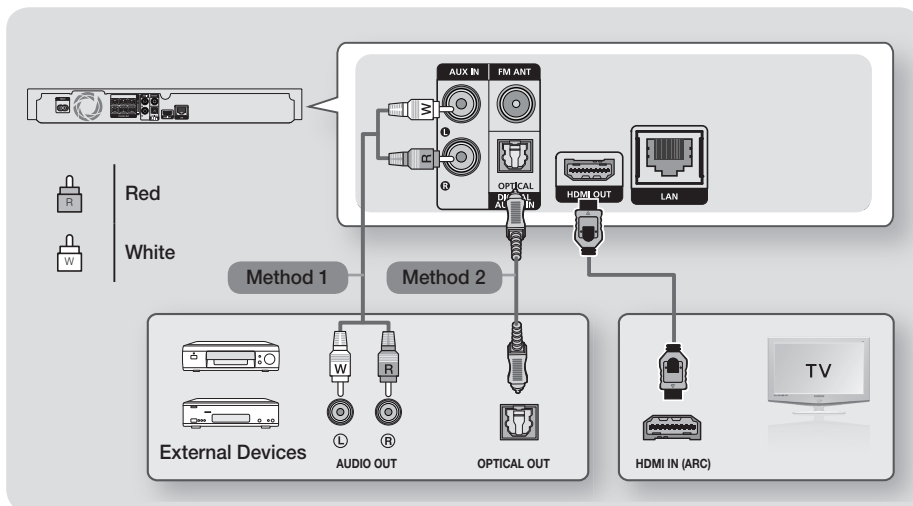

Connecting to a TV

Connect an HDMI cable from the HDMI OUT jack on the back of the product to the HDMI IN jack on your TV. If the TV supports ARC, you can hear the audio from your TV through the home theater with only this cable connected. See page 16 in this manual and the section on ARC in your TV's user's manual for details.

Connecting to External Devices

Two methods of connecting external devices to your home theater are explained below.

Method 1 AUX IN : Connecting an External Analog Component

Using an RCA audio cable (not supplied), connect the AUDIO In jack on the product to the AUDIO Out jack on the external analog component. ⇒ Select the **AUX** mode.

- Be sure to match the colors on the cable plugs to the colors on the input and output jacks.

Method 2 OPTICAL : Connecting an External Digital Audio Component

Use to connect the digital audio output of digital signal components such as Cable Boxes and Satellite Receivers (Set-Top-Boxes) to the home theater. Using a digital optical cable (not supplied), connect the Optical Digital Audio In jack on the product to the Digital Optical Out jack of the external digital device using a digital optical cable. ⇒ Select the **D. IN** mode.

- 🔗 To see video from your Cable Box/Satellite receiver, you must connect its video output directly to your TV.
- 🔗 This system supports Digital sampling frequencies of 32 kHz or higher from external digital components.
- 🔗 This system supports only DTS and Dolby Digital audio. MPEG audio, a bitstream format, is not supported.

Selecting an External Device to Use

To select an external device after you have connected it, press the **FUNCTION** button. Each time you press the button, the mode changes in this order : **BD/DVD** → **D. IN** → **AUX** → **FM** → **BT**

Connecting to a Network Router

You can connect your product to your network router using one of the methods illustrated below.

Wired Network

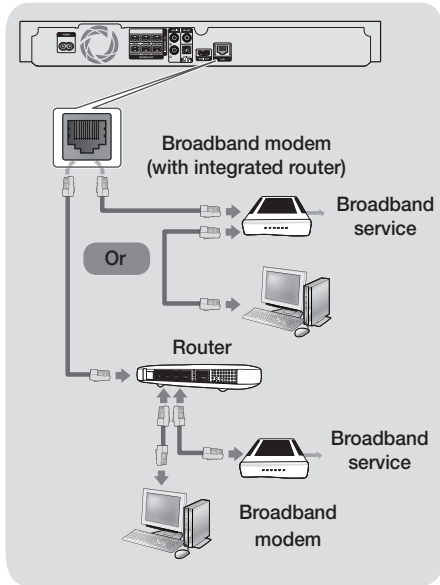

- 🔧 Your router or your Internet Service Provider's policies may prevent the product from accessing Samsung's software update server. If this occurs, contact your Internet Service Provider (ISP) for more information.
- 🔧 DSL users, please use a router to make a network connection.
- 🔧 Try to use the CAT 7 cable to connect.
- 🔧 You cannot use the product if the network speed is slower than 10Mbps.
- 🔧 To use the DLNA function, you must connect your PC to your network as shown in the illustrations above.

The connection can be wired or wireless.

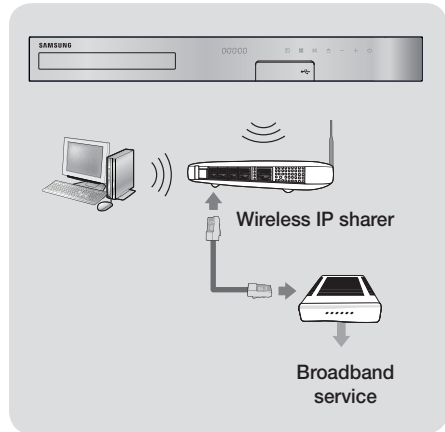

Wireless Network



- 🔧 If your wireless IP router supports DHCP, this product can use a DHCP or static IP address to connect to the wireless network.
- 🔧 Set your wireless IP router to Infrastructure mode. Ad-hoc mode is not supported.
- 🔧 The product supports only the following wireless security key protocols:
 - WEP (OPEN/SHARED), WPA-PSK (TKIP/AES), WPA2-PSK (TKIP/AES)
- 🔧 Select a channel on the wireless IP router that is not currently being used. If the channel set for the wireless IP router is currently being used by another device nearby, it will result in interference and communication failure.
- 🔧 In compliance with the newest Wi-Fi certification specifications, Samsung home theaters do not support WEP, TKIP, or TKIP-AES (WPS2 Mixed) security encryption in networks running in the 802.11n mode.
- 🔧 Wireless LAN, by its nature, may cause interference, depending on the operating conditions (AP performance, distance, obstacles, interference by other radio devices, etc.).

The Initial Settings Procedure

- The Home menu will not appear if you do not configure the initial settings.
- The OSD (On Screen Display) may change in this product after you upgrade the software version.
- The access steps may differ depending on the menu you selected.

1. Turn on your TV after connecting the product, and then turn on the product. When you turn on the product for the first time, the product automatically displays the **Setup** Language screen.
2. Press the ▲▼ buttons to select the desired language, and then press the  button.
3. Press the  button to start function setup.

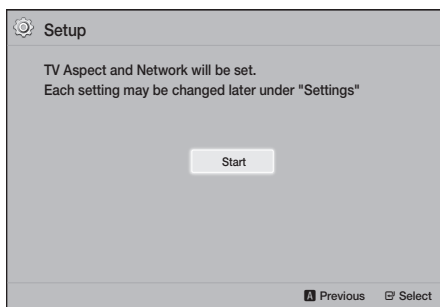





4. The **TV Aspect Ratio** screen appears. Press the ▲▼ buttons to select a TV aspect ratio, and then press the  button. You have four choices:
 - 16:9 Original** - For widescreen TVs. Displays widescreen pictures in their original 16:9 format and 4:3 pictures (the old, standard format) in 4:3 pillar box format with black bars on the left and right.
 - 16:9 Full** - For widescreen TVs. Displays widescreen pictures in their original 16:9 format and expands 4:3 pictures to fill the 16:9 screen.
 - 4:3 Letter Box** - For older, standard screen, analog TVs. Displays 4:3 pictures in full screen and 16:9 pictures in letter box format that retains the 16:9 aspect ratio but puts black bars above and below the picture.

4:3 Pan-Scan - For older, standard screen, analog TVs. Displays 4:3 pictures in full screen and 16:9 pictures in Pan-Scan format that fills the screen, but cuts off the left and right sides of the picture and enlarges the middle vertically.

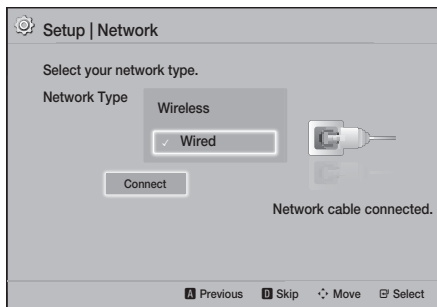
5. The **Network** screen appears.
 - Before you begin, confirm that the product is connected to your router.
 - Set to wired or wireless depending on your network environment.
 - If your wireless network has a security code, you will need to enter the code to complete the network connection.
 - If you have a network with static IP addresses, we suggest you select **Skip** by pressing the **BLUE (D)** button.

 If you skip network setup here or the setup does not work correctly, you can set up the product's network connection later. (See page 19)



6. The product verifies the network connection and then connects to the network. When it is done, press the  button. The **"Initial settings completed."** screen appears, and then the Home screen appears.
 -  If you want to display the **Setup** screen again and make changes, select the **Reset** option. (See page 18)
 -  If you use an HDMI cable to connect the product to an Anynet+ (HDMI-CEC)-compliant Samsung TV and 1.) You have set the **Anynet+ (HDMI-CEC)** feature to On in both the TV and the product and 2.) You have set the TV to a language supported by the product, the product will select that language as the preferred language automatically.

Settings

The Home Screen at a Glance

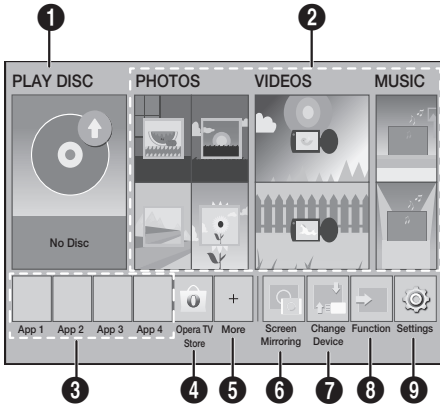

1 PLAY DISC

The disc currently in the tray is displayed. Press to start playing the disc.

2 PHOTOS/VIDEOS/MUSIC

Play photos, videos, or music content from a Disc, USB, PC, or mobile device.

3 Apps

Access various for pay or free-of-charge applications.

4 Opera TV Store

Access the on-line Opera TV Store where you will find high-quality video streaming, music streaming, gaming, and social network apps.

5 More

A list of useful and popular apps we recommend.
 Depending on your country, this menu function may not be supported.

6 Screen Mirroring

Set up the wireless mirroring function between the home theater and a smart phone or tablet.

7 Change Device

Displays a list of external devices connected to the main unit. Switch to the desired device.

8 Function

Use for switching to an external device, and for radio and mode switching for a Bluetooth connection. You can use the remote control's **FUNCTION** button and the main unit's button for mode switching.

9 Settings

Set various functions to suit your personal preferences.

To play or view video, photo, or music files located on your PC, you must connect your home theater and PC to a home network and have DLNA software installed on your PC. See page 24 and 35.

Accessing the Settings Screen

1. Select **Settings** on the Home screen, and then press . The **Settings** screen appears.

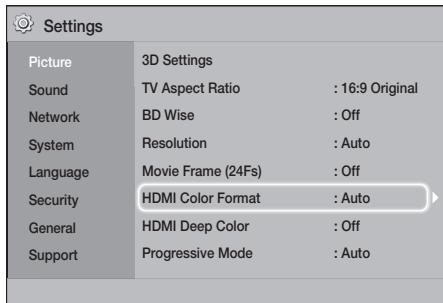

2. To access the menus, sub-menus, and options on the **Settings** screen, please refer to the remote control illustration. (See page 15)

If you leave the product in the stop mode for more than 5 minutes without using it, a screen saver appears on your TV. If the product is left in the screen saver mode for more than 20 minutes, the power automatically turns off.

Buttons on the Remote Control Used for the Settings Menu

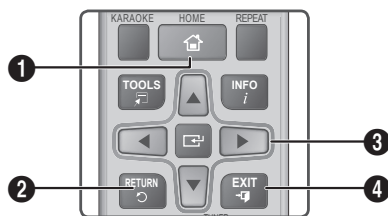

1	HOME Button : Press to move to the Home screen.
2	RETURN Button : Press to return to the previous menu.
3	(ENTER) / DIRECTION Button : <ul style="list-style-type: none"> Press ▲▼◀▶ to move the cursor or select an item. Press the (ENTER) button to activate the currently selected item or confirm a setting.
4	EXIT Button : Press to exit the current menu.

Detailed Function Information

Each **Settings** function, menu item, and individual option is explained in detail on-screen. To view an explanation, use the ▲▼◀▶ buttons to select the function, menu item, or option. The explanation will usually appear on the bottom of the screen.

A short description of each **Settings** function starts on this page. Additional information on some of the functions is also in the Appendix of this manual.

Settings Menu Functions

Picture

3D Settings

Set up the 3D related functions.

- ✓ **3D Blu-ray Playback Mode**: Select whether to play a Blu-ray Disc with 3D contents in 3D Mode. If you move to the Home menu while in 3D mode, the product will switch to 2D automatically.
- ✓ **Screen Size**: Enter the size of the TV attached to the product. The product will automatically adjust the 3D output to the screen size of the TV.

ⓘ Carefully read the health and safety information before viewing 3D content. (See page 3)

TV Aspect Ratio

Lets you adjust the output of the product to the screen size of your TV. (See page 38)

BD Wise

BD Wise is Samsung's latest inter-connectivity feature. When you connect a Samsung product and a Samsung TV with **BD Wise** to each other via HDMI, and **BD Wise** is on in both the product and TV, the product outputs video at the video resolution and frame rate of the Blu-ray/DVD Disc.

Resolution

Lets you set the output resolution of the HDMI video signal to **BD Wise, Auto, 1080p, 1080i, 720p, 576p/480p**. The number indicates the number of lines of video per frame. The i and p indicate interlaced and progressive scan, respectively. The more lines, the higher quality.

Movie Frame (24Fs)

Setting the **Movie Frame (24Fs)** feature to **Auto** lets the product adjust its HDMI output to 24 frames per second automatically for improved picture quality if attached to a 24Fs compatible TV.

- You can enjoy the **Movie Frame (24Fs)** feature only on a TV supporting this frame rate.
- Movie Frame is only available when the product is in the HDMI 1080p output resolution modes.

Settings

HDMI Color Format

Lets you set the color space format for the HDMI output to match the capabilities of the connected device (TV, monitor, etc).

HDMI Deep Color

Lets you set the product to output video from the HDMI OUT jack with Deep Color. Deep Color provides more accurate color reproduction with greater color depth.

Progressive Mode

Lets you improve picture quality when viewing DVDs.

Sound

Karaoke Scoring

This feature rates your singing ability and gives you a score for each song you sing.

My Karaoke

Set the volume of the vocals when using the karaoke feature.

- ✓ **Original Vocals:** Volume is set to the level of the original sound.
- ✓ **Reduce Vocals:** Volume is set to a level lower than that of the original sound.

Speaker Settings

Lets you adjust the following speaker settings and turn the speaker test on and off so you can test the speakers.

- ✓ **Level:** Lets you adjust the relative loudness of each speaker from 6dB to -6dB. For example, if you like deep bass, you can increase the loudness of the subwoofer by 6dB.
- ✓ **Distance:** Lets you adjust the relative distance of each speaker from the listening position up to 9 meters. The farther the distance, the louder the speaker will be.
- ✓ **Speaker Test:** Lets you run the **Speaker Test** function so you can test your adjustments. Setting **Speaker Test** to **On** turns the **Speaker Test** on. Setting it to **Off** turns it off.

Speaker Selection

Lets you select which speakers you want active, either the TV's speakers or the home theater's speakers.

Equalizer Mode

Set **Equalizer Mode** on to use the equalizer.

Equalizer Settings

Lets you set the equalizer.

- ✎ **Equalizer Settings** only appears when **Equalizer Mode** is **On**.

Audio Return Channel

Lets you direct the sound from the TV to the Home Theater speakers. Requires an HDMI connection and an **Audio Return Channel** (ARC) compatible TV.

- If **Audio Return Channel** is set to on and you are using an HDMI cable to connect the product to the TV, digital optical input will not work.
- If **Audio Return Channel** is set to **Auto** and you are using an HDMI cable to connect the product to the TV, ARC or digital optical input is selected automatically.

Digital Output

Lets you set the **Digital Output** to match the capabilities of the AV receiver you've connected to the product. For more details, please refer to the digital output selection table. (See page 43)

Dynamic Range Control

Lets you apply dynamic range control to Dolby Digital, Dolby Digital Plus, and Dolby TrueHD audio.

- ✓ **Auto:** Automatically controls the dynamic range of Dolby TrueHD audio, based on information in the Dolby TrueHD soundtrack. Also turns dynamic range control off for Dolby Digital and Dolby Digital Plus.
- ✓ **Off:** Leaves the dynamic range uncompressed, letting you hear the original sound.
- ✓ **On:** Turns dynamic range control on for all three Dolby formats. Quieter sounds are made louder and the volume of loud sounds is reduced.

Downmixing Mode

Lets you select the multi-channel downmix method that is compatible with your stereo system. You can choose to have the product downmix to **Normal Stereo** or to **Surround Compatible**.

Audio Sync

When the product is attached to a digital TV, lets you adjust the audio delay so that the audio syncs with the video. You can set the delay between 0 and 300 milliseconds.

Network

Network Settings

Lets you configure the network connection so you can enjoy various features such as Internet services or DLNA Wi-Fi functionality, and perform software upgrades.

Network Test

Lets you test the Internet Protocol setup to see if it is working correctly.

Network Status

Lets you check the current network and Internet status.

Wi-Fi Direct

Lets you connect a **Wi-Fi Direct** device to the product using a peer-to-peer network, without the need for a wireless router.

Note that if the product is connected to a wireless network, it may be disconnected when you use **Wi-Fi Direct**. (See page 22)

 Text files, such as files with a .TXT or .DOC extension, will not display when you are using the **Wi-Fi Direct** function.

Screen Mirroring

The **Screen Mirroring** function lets you view the screen of your smart phone or smart device on the TV you have connected to the home theater system. (See page 37)

Device Name

Lets you assign an identifying name to the product. You use this name to identify the product when you are connecting external Wi-Fi devices (smart phones, tablets, etc.) to it.

BD-Live Internet Connection

Lets you allow or prohibit an Internet connection for the BD-Live service.

System

Setup

Lets you re-run the **Setup** procedure. (See page 13)

Quick Start

You can turn on the power quickly by decreasing the boot time.

 If this function is set to **On**, Standby power consumption will be increased. (About 12W ~ 20W)

Anynet+ (HDMI-CEC)

Anynet+ is a convenient function that offers linked operations with other Samsung products that have the Anynet+ feature and lets you control those products with one Samsung TV remote. To operate this function, you must connect this product to an Anynet+ Samsung TV using an HDMI cable.

BD Data Management

Lets you manage the contents you downloaded through a Blu-ray disc that supports the BD-Live service. You can view information about the USB device you are using for BD Live data storage including the available storage space. You can also delete BD Live data and change the device.

DivX® Video On Demand

View DivX® VOD Registration Codes to purchase and play DivX® VOD contents.

Language

Lets you select the language you prefer for the **On-Screen Menu**, **Disc Menu**, etc.

- The selected language will only appear if it is supported on the disc.

Settings

Security

The default PIN is 0000. Enter the default PIN to access the security function if you haven't created your own PIN.

BD Parental Rating

Prevents playback of Blu-ray Discs with a rating equal to or above a specific age rating unless you enter the PIN.

DVD Parental Rating

Prevents playback of DVDs with a rating above a specific numerical rating unless you enter the PIN.

Change PIN

Changes the 4-digit PIN used to access security functions.

General

Time Zone

Lets you specify the time zone that is applicable to your area.

Support

Software Upgrade

For more information about this function, see page 23.

Contact Samsung

Provides contact information for assistance with your product.

Terms of Service Agreement

View the general disclaimer regarding third party contents and services.



Reset

Reverts all settings to their defaults except for the network. Requires that you enter your security PIN. The default security PIN is 0000.

Radio Setup

- To listen to the radio, you must connect the supplied FM antenna.

Operating the Radio with the Remote Control

1. Press the **FUNCTION** button to select **FM**.
2. Tune to the desired station.
 - **Preset Tuning 1** : Press the  button to select **PRESET**, and then press the **TUNING UP, DOWN** button to select a preset station.
 - Before you can tune to preset stations, you must add preset stations to the product's memory.
 - **Manual Tuning** : Press the  button to select **MANUAL**, and then press the **TUNING UP, DOWN** button to tune in to a lower or higher frequency.
 - **Automatic Tuning** : Press the  button to select **MANUAL**, and then press and hold the **TUNING UP, DOWN** button for a few seconds to automatically search the band.

Selecting Mono or Stereo

Press the **MO/ST** button.

- Each time you press the button, the sound switches between **STEREO** and **MONO**.
- In a poor reception area, select **MONO** for a clear, interference-free broadcast.

Presetting Stations

Example : Presetting FM 89.10 into memory.

1. Press the **FUNCTION** button to select **FM**.
2. Press the **TUNING UP, DOWN** button to scroll the FM frequencies, and then select <89.10>.
3. Press the **TUNER MEMORY** button (the yellow **C** button at the bottom of the remote).
4. Press the **TUNER MEMORY** button again within about 5 seconds. The station is stored in memory.
 -  If you press the **TUNER MEMORY** button repeatedly without changing the station, the inputted station may be overwritten.
5. To preset another station, repeat steps 2 to 4.
 - To tune in to a preset station, press the **TUNING UP, DOWN** button.

- To delete all Preset FM stations at once, press the **TITLE MENU** button for about 5 seconds in FM Manual mode until **DEFAULT PRESET** appears on the display.

Recording FM Radio

You can record your favorite radio broadcast on a USB storage device.

1. Insert a USB device into the USB jack on the front of the product.
2. Press the **FUNCTION** button to select **FM**, and then press the **TUNING UP, DOWN** button to select the station you want to record.
3. Press the **RED (A)** button to start recording. The recording process begins.
 - The recorded time is displayed on the left and the recording time still available, based on the amount of free space in the USB storage device, is displayed on the right.
4. Press the **EXIT** button to finish your recording. The recording is stopped and saved as an .mp3 file at the same time. To play the recorded file, refer to "Playing Files on a USB Device".

- The recorded file is saved in the **Tuner** folder which is created automatically.

- Only the **OPEN/CLOSE**, **POWER**, **EXIT**, **MUTE**, and **VOLUME +/-** buttons are operable while FM radio is being recorded.

- If you don't press any buttons while recording, the screen saver will be enabled.

- Sound effects, such as **DSP**, **EQ**, etc., are not recorded during FM radio recording.

- The radio is recorded at a set, default volume even if you change the volume or press the **MUTE** button during the recording process.

- If you remove the USB device or Power Cable during the recording process, the portion of the file which has already been recorded may not play back.

- Recording will not start if the remaining free space in the USB storage device is less than 2MB.

- If the USB device is removed or has insufficient space (under 2MB), the appropriate message is displayed and the recording stops.

Network Setup

When you connect this product to a network, you can use network based applications and functions such as **BD-LIVE** and upgrade the product's software through the network connection.

Configuring Your Network Connection

To begin configuring your network connection, follow these steps:

1. In the Home screen, select **Settings**, and then press the **OK** button.
2. Select **Network**, and then press the **OK** button.
3. Select **Network Settings**, and then press the **OK** button.
4. Go to the instructions for Wired networks starting below or the instructions for Wireless networks. (See page 20)

Wired Network

□ Wired – Automatic

After following Steps 1 to 3 above:

1. In the **Network Settings** screen, change **Network Type to Wired**. Then, select **Connect** and press the **OK** button. The product detects the wired connection, verifies the network connection, and then connects to the network.
2. When it is done, highlight **OK**, and then press **OK** button.

□ Wired - Manual

If you have a static IP address or the automatic procedure does not work, you'll need to set the **Network Settings** values manually.

After following Steps 1 to 3 above:

1. In the **Network Settings** screen, change **Network Type to Wired**. Then, select **Connect** and press the **OK** button. The product searches for a network, and then displays the connection failed message.
 - If it is possible to connect the home theater to your network wirelessly, select **Change Network** at this point, change the **Network Type to Wireless**, and then go to the instructions for wireless networks. (See page 20)

Settings

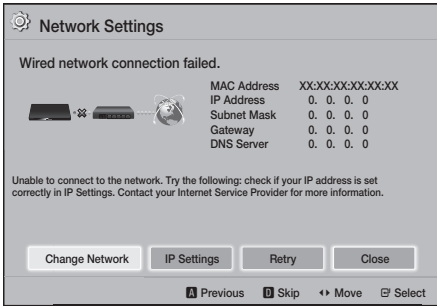

2. Use the ◀▶ buttons to select **IP Settings**, and then press the button. The **IP Settings** screen appears.
 3. Select the **IP Setting** field, and then set it to **Enter manually**.
 4. Select a parameter to enter (**IP Address**, for example), and then press . Use the number keypad on your remote control to enter the numbers for the parameter. You can also enter numbers using the ▲▼ buttons. Use the ◀▶ buttons on the remote control to move from entry field to entry field within a parameter. When done with one parameter, press the button.
 5. Press the ▲ or ▼ button to move to another parameter, and then enter the numbers for that parameter following the instructions in Step 4.
 6. Repeat Steps 4 and 5 until you have filled in all parameters.
- You can get the network parameter values from your Internet provider.
7. When finished entering all the parameter values, select **Return** (↵), and then press the button. The home theater verifies the network connection and then connects to the network.

Wireless Network

You can set up a wireless network connection in three ways:

- Wireless Automatic
- Wireless Manual
- WPS(PBC)

Before you configure the wireless network connection, disconnect any wireless network devices currently connected to the product or, if applicable, the product's current wired connection.

❑ Wireless - Automatic

Follow the Steps 1 to 3 in "Configuring Your Network Connection". (See page 19)

1. In the **Network Settings** screen, change **Network Type** to **Wireless**. The product searches for and then displays a list of the available networks.

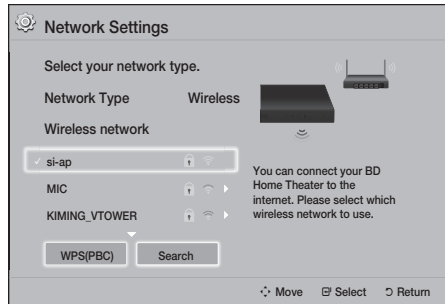





2. Select the desired network, and then press the button.
 3. On the **Security Key** screen, enter your network's security code or pass phrase. Enter numbers directly using the number buttons on your remote control. Enter letters by selecting a letter with ▲▼◀▶ buttons, and then pressing .
 4. When finished, select **Done**, and then press the button. The product verifies the network connection and then connects to the network.
- You should be able to find the security code or pass phrase on one of the set up screens you used to set up your router or modem.

❑ Wireless - Manual



If you have a static IP address or the Automatic procedure does not work, you'll need to set the **Network Settings** values manually.

Follow the Steps 1 to 3 in "Configuring Your Network Connection". (See page 19)



1. In the **Network Settings** screen, change **Network Type** to **Wireless**. The product searches for and then displays a list of the available networks.
2. Scroll through the list, select the desired network or **Add Network**, and then press the button.
3. If you selected a network in Step 2, go to Step 6. If you selected **Add Network**, go to Step 4.

4. Enter your wireless network or wireless router's name.
 - Enter numbers directly using the number buttons on your remote control.
 - Enter letters by selecting a letter with the ▲▼◀▶ buttons, and then pressing the  button.
 - To display capital letters (or redisplay lower case letters if capital letters are displayed), select , and then press the  button.
 - To display symbols and punctuation, select **123#&**, and then press the  button. To redisplay letters, select **123#&**, and then press the  button.





When finished, select **Done**, and then press the  button.

5. On the **Security method** screen that appears, use the ▲▼ buttons to select the network's Security method, and then press the  button. On the next screen, enter your network's security code or pass phrase.
 - Enter numbers directly using the number buttons on your remote control.
 - Enter letters by selecting a letter with the ▲▼◀▶ buttons, and then pressing the  button.

When finished, select **Done**, and then press the  button. The product searches for the network.

6. The Network connection fail screen appears. Use ◀▶ buttons to select **IP Settings**, and then press the  button.
7. Select the **IP Setting** field, and then set it to **Enter manually**.
8. Select a network parameter to enter (**IP Address**, for example), and then press  button. Use the number keypad on your remote control to enter the numbers for the parameter. You can also enter numbers using the ▲▼ buttons. Use the ◀▶ buttons on the remote control to move from entry field to entry field within a parameter. When done with one value, press the  button.
9. Press the ▲ or ▼ button to move to another parameter, and then enter the numbers for that parameter following the instructions in Step 8.
10. Repeat Steps 8 and 9 until you have filled in all parameters.

 You can get the Network parameter values from your Internet provider.



11. When finished, select **Return** (↵), and then press the  button. The **Security Key** screen appears.
12. On the **Security Key** screen, enter your network's Security Code or Pass Phrase. Enter numbers directly using the number buttons on your remote control. Enter letters by selecting a letter with the ▲▼◀▶ buttons, and then pressing the  button.
13. When finished, select **Done** at the right of the screen, and then press the  button. The product verifies the network connection and then connects to the network.
14. After the home theater verifies the network, select **OK**, and then press the  button.

 You can also begin the Manual Network setup by going to **Settings > Network > Network Status**.

□ WPS(PBC)

One of the easiest ways to set up the wireless network connection is using the **WPS(PBC)** function. If your wireless router has a **WPS(PBC)** button, follow these steps:



Follow the Steps 1 to 3 in "Configuring Your Network Connection". (See page 19)

1. In the **Network Settings** screen, change **Network Type** to **Wireless**. The product searches for and then displays a list of the available networks.
 2. Scroll the list down, select **WPS(PBC)**, and then press the  button.
 3. Press the **WPS(PBC)** button on your router within two minutes. Your product automatically acquires all the network settings values it needs and connects to your network after the network connection is verified.
 4. When it is done, highlight **OK**, and then press the  button.
-  For a WPS connection, set your wireless router's security encryption to AES. WEP security encryption does not support a WPS connection.

Settings

Wi-Fi Direct

The **Wi-Fi Direct** function allows you to connect **Wi-Fi Direct** devices to the product and each other using a peer-to-peer network, without a wireless router.

- 📎 Some **Wi-Fi Direct** devices may not support the DLNA function if connected via **Wi-Fi Direct**. If this is the case, change the network connection method you used to connect the device to the home theater.
 - 📎 **Wi-Fi Direct** transmissions can interfere with Bluetooth signals. Before you use the **Bluetooth** function, we strongly recommend that you turn off the **Wi-Fi Direct** function on any device in which it is currently on.
1. Turn on the **Wi-Fi Direct** device and activate its **Wi-Fi Direct** function.
 2. In the Home screen, select **Settings**, and then press the  button.
 3. Select **Network**, and then press the  button.
 4. Select **Wi-Fi Direct**, and then press the  button.
The **Wi-Fi Direct** devices that you can connect to appear.





5. You have three ways to complete the Wi-Fi connection:

- Through the Wi-Fi device.
- Through the product using PBC.
- Through the product using a PIN.

Each is covered below.

Through the Wi-Fi Device

1. On the Wi-Fi device, follow the device's procedure for connecting to another **Wi-Fi Direct** device. See the device's user manual for instructions.
2. When you have completed the procedure, you should see a pop-up on your TV screen saying that a device that supports **Wi-Fi Direct** has requested to connect. Confirm that the device that is making the request is your device, select **Yes** in the pop up, and then press the  button to accept.
3. The Connecting pop-up appears, followed by the Connected pop-up. You should see the device listed as connected on the **Wi-Fi Direct** screen, and then press the  button.



- The PBC and PIN procedures connect devices automatically.

Through the Product Using PBC

1. Select the **Wi-Fi Direct** device you want to connect to this product, and then press the  button.
2. The Connecting pop-up appears, followed by the Connected pop-up. When it closes, you should see the device listed as connected on the **Wi-Fi Direct** screen.

Through the Product Using a PIN







1. Select the **Wi-Fi Direct** device you want to connect to this product, and then press the  button.
2. The PIN pop-up appears.
3. Note the PIN code in the pop-up, and then enter it into the appropriate field in the **Wi-Fi Direct** device you want to connect.

- The Connecting pop-up appears, followed by the Connected pop-up. When it closes, you should see the device listed as connected on the **Wi-Fi Direct** screen.
-  The current wired or wireless network connection will be disconnected when you use the **Wi-Fi Direct** function.
-  Text files, such as files with a .TXT or .DOC extension, will not display when you are using the **Wi-Fi Direct** function.

Upgrading Software

The **Software Upgrade** menu allows you to upgrade the product's software for performance improvements or additional services.

- Never turn the product off or back on manually during the update process.
- The update is complete when the product turns off after restarting. Press the **POWER** button to turn on the updated product for your use.
- Samsung Electronics takes no legal responsibility for product malfunction caused by an unstable Internet connection or consumer negligence during a software upgrade.



- In the Home menu, select **Settings**, and then press the  button.
- Select **Support**, and then press the  button.
- Select **Software Upgrade**, and then press the  button.
- Select one of the following methods:
 - **By Online**
 - **By USB**
 - **Auto Upgrade Notification**
- Press the  button.
Directions for each method begin below.
-  If you want to cancel the upgrade while the upgrade software is downloading, press the  button.

By Online

Your product must be connected to the Internet to use the **By Online** function. Remove all discs before you begin.

- Select **By Online**, and then press the  button. The Connecting to Server message appears.
- If an update is available, a popup message appears asking if you want to upgrade. If you select **Yes**, the product turns off automatically, turns on, and then begins the upgrade.
- The update progress popup appears. When the update is completed, the product turns off automatically again.
- Press the **POWER** button to turn on the product.

By USB

- Visit Samsung's website on a computer and download the update package to a USB device.
-  Save the update package in the USB device's top-level folder. Otherwise, the product will not be able to locate the update package.
- Connect the USB device with the update package to the product.
- Select **Support > Software Upgrade > By USB**. The software is updated using the update package on the USB device.
-  There should be no disc in the product when you upgrade the software using the USB Host jack.
-  When the software upgrade is done, check the software details in the **Software Upgrade** menu.

Auto Upgrade Notification

If your product is connected to the network and you set **Auto Upgrade Notification** on, the product will notify you if a new software version is available with a pop-up message.

- Turn on the product.
- In the **Software Upgrade** menu, set **Auto Upgrade Notification** to **On**.
If there is a new software version available, the product will notify you with a pop-up message.

Settings

3. To upgrade the firmware, select **Yes**. The product turns off automatically, turns on, and then begins the upgrade.
4. The update progress popup will appear. When the update is complete, the product will turn off automatically again.
5. Press the **POWER** button to turn on the product.

Setting Up DLNA

DLNA lets you play music, video, and photo files stored in your PC through your home theater.

To use DLNA, you must install DLNA software or already have DLNA software installed on your PC and connect the home theater to your PC via your network (See page 12).

-  PCs running Windows 7 and Windows 8 have DLNA software (Play To) built in.

Playing Content

Your home theater can play content located on Blu-ray/DVD/CD discs, USB devices, PCs, smart phones, tablets, and in Apps.

To play content located on your PC or a mobile device, you must connect the PC or mobile device and the product to your network. To play content on your PC, you must also download and install DLNA network software or already have DLNA network software on your PC.

 PCs running Windows 7 and Windows 8 have DLNA software (Play To) built in.

Switching the Source Device

If two or more external devices are connected to the main unit, you can use any of the three methods described below to change the source device.

Method 1

From the Home screen, use the **▲▼◀▶** buttons to move to **Change Device**, and then press .

The **Change Device** popup window will appear. Use the **▲▼** buttons to move to the desired device, and then press .

Method 2

If you move to **PHOTOS, VIDEOS, MUSIC** or other file-based contents, a list of folders and files will appear. Press the **RED (A)** button to display the **Change Device** popup window, use the **▲▼** buttons to move to the desired device, and then press .

Method 3

When a device is connected for the first time, a popup window appears. In the popup, you can change the source device by using the **◀▶** buttons, and then pressing .

Playing Commercial Discs

1. Press the **▲** button to open the disc tray.
2. Place a disc gently into the disc tray with the disc's label facing up.



3. Press the **▲** button to close the disc tray. Playback starts automatically.
4. If playback does not start automatically, press the  button on the remote.

Disc Storage & Management

• Holding Discs

- Fingerprints or scratches on a disc may reduce sound and picture quality or cause skipping.
- Avoid touching the surface of a disc where data has been recorded.
- Hold the disc by the edges so that fingerprints will not get on the surface.
- Do not stick paper or tape on the disc.



• Cleaning Discs

- If you get fingerprints or dirt on a disc, clean it with a mild detergent diluted in water and wipe with a soft cloth.
- When cleaning, wipe gently from the inside to the outside of the disc.



- Disc Storage

- Do not keep in direct sunlight.
- Keep in a cool ventilated area.
- Keep in a clean protective jacket and store vertically.

Playing a Disc with User Recorded Content



You can play multimedia files you have recorded on Blu-ray, DVD, or CD discs.

1. Place a user recorded disc into the disc tray with the disc's label facing up, and then close the tray.
2. Use the **▲▼◀▶** buttons to select the type of content you want to view or play - **PHOTOS, VIDEOS, or MUSIC** - and then press the  button.

OR

- 2¹. Select **PLAY DISC** from the Home screen. The **PLAY DISC** screen appears. Use the **▲▼** buttons to select the desired content type, **Photos, Videos, or Music**.

Playing Content

3. A screen appears listing the contents of the disc. Depending on how the contents are arranged, you will see either folders, individual files, or both.
4. If necessary, use the ▲▼◀▶ buttons to select a folder, and then press the  button.
5. Use the ▲▼◀▶ buttons to select a file to view or play, and then press the  button.
6. Press the RETURN button one or more times to exit a current screen, exit a folder, or to return to the Home screen. Press the EXIT button to return directly to the Home Screen.
7. Go to pages 27~31 for instructions that explain how to control playback of videos, music, and pictures on a disc.



Playing Files on a USB Device



There are two methods you can use to play or view multimedia files located on a USB device through your product.

Method 1 : If you connect a USB device while the product is turned on



1. The "New device connected." pop-up appears.





-  If the pop-up does not appear, go to Method 2.
2. Use the ▲▼ buttons to select **Photos**, **Videos**, or **Music** and then press the  button. Depending on how the contents are arranged, you will see either folders, individual files, or both.

3. If necessary, use the ▲▼◀▶ buttons to select a folder, and then press the  button.
4. Select a file to view or play, and then press the  button.
5. Press the RETURN button to exit a folder or the EXIT button to return to the Home screen.
6. Go to pages 27~31 for instructions that explain how to control playback of videos, music, and pictures on a USB device.

Method 2 : If the product is turned on after you connect a USB device

1. Turn the product on.
2. Press **Change Device** and select a USB device.
3. Use the ▶ buttons to select **PHOTOS**, **VIDEOS**, or **MUSIC** on the Home screen, and then press the  button.
4. If necessary, use the ▲▼◀▶ buttons to select a folder, and then press the  button.
5. Select a file to view or play, and then press the  button.
6. Press the RETURN button to exit a folder or the EXIT button to return to the Home screen.
7. Go to pages 27~31 for instructions that explain how to control playback of videos, music, and pictures on a USB device.

 If you insert a disc while playing a USB device or phone, the device mode changes to "Disc" automatically.

 If your cellular phone is DLNA compatible, you can play content on the phone without connecting a USB cable. (See page 35)

Controlling Video Playback

You can control the playback of video content located on a Blu-ray/DVD disc, USB device, mobile device, or PC. Depending on the disc or contents, some of the functions described in this manual may not be available.

Buttons on the Remote Control used for Video Playback

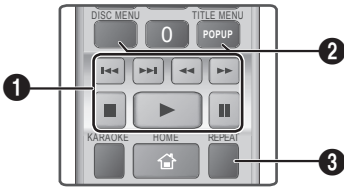

1 Playback related buttons

The product does not play sound in **Search**, **Slow**, or **Step** mode.

- To return to normal speed playback, press the button.

	Starts playback.
	Stops playback.
	Pauses playback.
Fast Motion Play	During playback, press the or button. Each time you press the or button, the playback speed will change.
Slow Motion Play	In pause mode, press the button. Each time you press the button, the playback speed will change.
Step Motion Play	In pause mode, press the button. Each time you press the button, a new frame appears.
Skip Motion Play	During playback, press the or button. Each time you press the or button, the disc moves to the previous or next chapter or file.

2 Using the disc menu, title menu, popup menu, and title list

DISC MENU

During playback, press this button to display the Disc menu.

TITLE MENU

During playback, press this button to display the Title menu.

- If your disc has a playlist, press the **GREEN (B)** button to go to the playlist.

POPUP MENU

During playback, press this button to display the Popup menu.

3 Repeat Playback

- During playback, press the **REPEAT** button on the remote control.
- Press the buttons to select **Off**, **Title**, **Chapter**, **All** or **Repeat A-B**, and then press the button.

Repeat A-B

- Press the button at the point where you want repeat play to start (A).
 - Press the button at the point where you want repeat play to stop (B).
 - To return to normal play, press the **REPEAT** button again.
 - Press the button.
- Depending on the disc, the screen may not display all repeat options.
 - The screen may not display **Chapter** or **Title** immediately. Continue to press the buttons until your choice is inside the applicable field.
 - To return to normal play, press the **REPEAT** button again, press the buttons to select **Off**, and then press the button.
 - The screen may not display **Repeat A-B** immediately. Continue to press the buttons until **Repeat A-B** is inside the applicable field.
 - You must set point (B) at least 5 seconds of playing time after point (A).

Playing Content

Using the TOOLS Menu

During playback, press the **TOOLS** button.

Title

If there is more than one title on a disk or device, lets you move to or select a desired title.

- ✎ When searching DVD title, in stop mode, enter the **TOOLS** button and title number (01,02,...) you want.

Playing Time

Lets you go to a specific playback point. Use the numeric buttons to input the playback point.

Repeat Mode

Lets you repeat a specific title, chapter, or marked section.

Audio Sync

Lets you adjust the audio delay so that the audio syncs with the video. You can set the delay from 0 to 300 milliseconds.

Equalizer Mode

Set **Equalizer Mode** on to use the equalizer.

Equalizer Settings

Lets you set the equalizer.

- ✎ Equalizer Settings only appears when **Equalizer Mode** is On.

Picture Settings

Lets you set the picture mode.

▪ Mode

- **User** : Go to **Advanced Settings**, and then press the  button. Lets you adjust the **Brightness**, **Contrast**, **Color**, and **Sharpness** functions manually.
- **Dynamic** : Choose this setting to increase sharpness.
- **Normal** : Choose this setting for most viewing applications.
- **Movie** : This is the best setting for watching movies.

Menu selections that appear only when a BD/DVD disc plays

Chapter

Lets you move to a chapter that you want to watch.

Audio

Lets you set the desired audio language.

Subtitle

Lets you set the desired subtitle language.

Angle

To view a scene from another angle. The **Angle** option displays the number of angles available to view (1/1, 1/2, 1/3, etc.).

BONUSVIEW Video

BONUSVIEW Audio

Lets you set the desired Bonusview option.

Menu selections that appear only while a file plays

Full Screen

Lets you set the desired full screen size. You can select **Original**, **Mode1** (larger), and **Mode2** (largest).

Information

Select to view video file information.

- ✎ Depending on the disc or storage device, the Tools menu may differ. All options may not be displayed.

Creating a Video Playlist

You can create a playlist of video files in nearly the same way you create a playlist of music files. See page 30 for instructions. Select video files instead of music files.

Playing a Pre-Recorded Commercial Audio Disc

1. Insert an Audio CD (CD-DA) or an MP3 Disc into the disc tray.
 - For an Audio CD (CD-DA), the first track will be played automatically. Tracks on a disc are played in the order in which they were recorded on the disc.
 - For an MP3 disc, press the ◀▶ buttons to select **MUSIC**, then press the button.

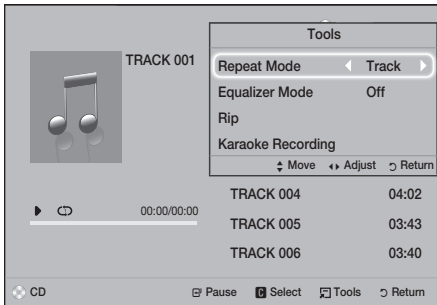

2. To play a particular track, use the ▲▼ buttons on the remote to select the track, and then press the button.
 - For more information about playing music, see Controlling Music Playback below.

Controlling Music Playback

You can control the playback of music content located on a DVD, CD, USB, mobile device, or PC. Depending on the disc or contents, some of the functions described in this manual may not be available.

Buttons on the Remote Control used for Music Playback

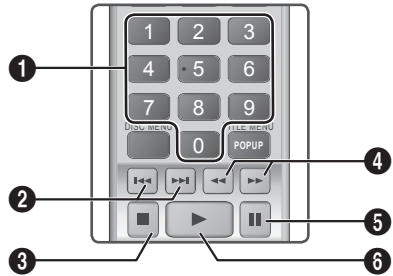

1	Number buttons : During Playlist playback, press the desired track number. The selected track is played.
2	Skip : During playback, press the ◀▶ or ▶▶ button to move to the previous or next music track.
3	button : Stops a track.
4	Fast Play (Audio CD [CD-DA] only) : During playback, press the ◀▶ or ▶▶ button. Each time you press the ◀▶ or ▶▶ button, the playback speed will change.
5	button : Pauses a track.
6	button : Plays the currently selected track.

Repeating Tracks

You can set the product to repeat tracks.

1. During music playback, press the **TOOLS** button.
2. Select **Repeat Mode**, then use the ◀▶ buttons to select **Off**, **Track** or **One**, **All** or **Shuffle**, and then press the button.

Playing Content

Creating a Music Playlist

1. If you are playing music from a commercial CD or DVD, press the **■** or **RETURN** button. The Music List Screen appears. If you are creating a playlist from music on a user created disk or USB device, access the Music list as described on page 25 or 26.
2. Press the **▲▼◀▶** buttons to move to a desired file, and then press the **YELLOW (C)** button to select it. Repeat this procedure to select additional files.
3. If you want to select all files, press the **TOOLS** button, use the **▲▼** buttons to select **Select All**, and then press **☑**. If you want to deselect all files, press the **TOOLS** button, select **Deselect All**, and then press **☑**.



4. To remove a file from the **Playlist**, move to the file, and then press the **YELLOW (C)** button.
 5. Press the **☑** button to play the selected files. The **Playlist** screen appears.
 6. To go to the Music List, press the **■** or **RETURN** button.
 7. To go back to the **Playlist**, press the **☑** button.
- ☞* You can create a playlist with up to 99 tracks on Audio CDs (CD-DA).
- ☞* If you go to the Music List from the **Playlist**, and then return to the **Playlist**, the **Playlist** will start playing again from the beginning.

Ripping

1. Insert a USB device into the USB jack on the front of the product.
2. With the Playback screen displayed, use the **▲▼** buttons to select a track, and then press the **YELLOW (C)** button. A check appears to the left of the track.
3. Repeat Step 2 to select and check additional tracks.
4. To remove a track from the list, move to the track, and then press the **YELLOW (C)** button again. The check on the track is removed.
5. When done, press the **TOOLS** button. The **Tools** menu appears.
6. Use the **▲▼** buttons to select **Rip**, and then press the **☑** button. The **Rip** screen appears.
7. Use the **▲▼** buttons to select the device to store the ripped files on, and then press the **☑** button.

☞ Do not disconnect the device while ripping is in progress.

8. If you want to cancel ripping, press the **☑** button, and then select **Yes**. Select **No** to continue ripping.
9. When ripping is complete, the "**Ripping is completed.**" message appears.
10. Press the **☑** button to go back to the Playback screen.

☞ This function is not available for DTS Audio CDs.

☞ This function may not be supported by some discs.

☞ Ripping encodes music in the .mp3 format at 192kbps.

☞ On the Track list screen, you can choose **Select All** or **Deselect All**.

- Use **Select All** to select all tracks, and then press the **☑** button. This cancels your individual track selections.
- Use **Deselect All** to deselect all selected tracks at once.

Playing Photo Content

You can play photo content located on a DVD, USB, mobile device, or PC.

Using the Tools Menu

During playback, press the **TOOLS** button.

Start / Stop Slide Show

Select to play/pause the slide show.

Slide Show Speed

Select to adjust the slide show speed.

Background Music

Select to listen to music while viewing a slide show.

Zoom



Select to enlarge the current picture.
(Enlarge up to 4 times)

Rotate

Select to rotate a picture. (This will rotate the picture either clockwise or counter clockwise.)

Information

Shows the picture information including the file name and size, etc.



-  Depending on the disc or storage device, the **Tools** menu may differ. All options may not be displayed.
-  To enable the background music function, the photo file must be in the same storage media as the music file. However, the sound quality can be affected by the bitrate of the MP3 file, the size of the photo, and the encoding method.

Creating a Photo Playlist

You can create a photo playlist in nearly the same way you create a music playlist. See page 30 for instructions. Select photo files instead of music files.









Using Karaoke

You can enjoy the Karaoke with music.

1. Connect the microphone on the front of the product.
2. In the Home menu, select the **Settings**, and then press the  button.
3. Select the **Sound**, and then press the  button.
4. Select **My Karaoke**, and then press the  button.
 - You can check the Karaoke score and adjust the volume of playback music's vocal.
 - Your Karaoke score is automatically displayed if **Karaoke Scoring** is set to **On** and a microphone is connected. If you don't want to see the score, set **Karaoke Scoring** to **Off**.
 - If you want to decrease the volume of the vocals in the original sound, select **Reduce Vocals** in **My Karaoke** settings.

Recording

You can make a recording of karaoke with music.

1. During the playback, press the **TOOLS** button to select **Karaoke Recording**, and then press  button.
2. Press  button if you want to finish recording.
3. When recording is done, KARAOKE folder is created in the USB storage driver and saved as the form of KARAOKEL.mp3.
 -  To save recording file, USB storage driver must be inserted.
 -  Recording file is shown if you re-entry to **Photos**, **Videos**, and **Music**.
 -  If you hear strange noises (squealing or howling) while using the Karaoke feature, move the microphone away from the speakers. Turning down the microphone's volume or the speaker volume is also effective.
 -  The microphone does not operate in the **D. IN**, **AUX**, **FM** and **BT** mode.
 -  The karaoke scoring displays the score automatically when the **Karaoke Scoring** is set to **On** and a microphone is connected. Disconnect the microphone if you do not want to display the score.
 -  The mic becomes available 10 seconds after the Home menu appears on the screen.

Playing Content

Using Bluetooth

You can use a Bluetooth device to enjoy music with high quality stereo sound, all without wires!

- Pairing distance : max. 2M,
Operating distance : max. 10M
- Actual Bluetooth performance may differ depending on your environment, even if you use your Bluetooth device within the specified operating distance.

What is Bluetooth?

Bluetooth is a technology that enables Bluetooth-compliant devices to interconnect with each other easily using a short, wireless connection.

- A Bluetooth device may hum or malfunction:
 - When a part of your body is in contact with the receiving/transmitting system of the Bluetooth device or the Home Theater.
 - When the device is subject to electrical variation from obstructions caused by a wall, corner, or office partitioning.
 - When the device is exposed to electrical interference from same frequency-band devices including medical equipment, microwave ovens, and wireless LANs.
- Pair the Home Theater with the Bluetooth device while the two are close together.
- The further the distance is between the Home Theater and the Bluetooth device, the worse the quality is.
If the distance exceeds the Bluetooth operational range, the connection is lost.
- In poor reception-sensitivity areas, the Bluetooth connection may not work properly.
- The Home Theater has an effective reception range of up to 10 meters in all directions if there are no obstacles. The connection will be automatically cut off if the device is out of this range. Even within this range, the sound quality may be degraded by obstacles such as walls or doors.
- This wireless device may cause electrical interference. during its operation.

To Connect the Home Theater to a Bluetooth Device

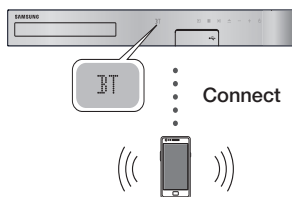

Bluetooth device

Before you begin, confirm that the Bluetooth device supports the Bluetooth compliant stereo headset function.

1. Press the **FUNCTION** button on the remote control to display the **BT** message.
 2. Select the Bluetooth menu on the Bluetooth device you want to connect. For instructions, refer to the Bluetooth device's manual.
 3. Select "[HTS]JXXXXX" from the list.
 - When the Home Theater is connected to the Bluetooth device, the device name of the connected Bluetooth device, followed by the name of the home theater, will appear on the front display of the home theater.
 4. Play music on the connected device.
 - You can listen to the music playing on the connected Bluetooth device over the Home Theater system.
- 🔑 The Home Theater only supports Middle Quality SBC data (up to 237kbps@48kHz), and does not support High Quality SBC data (328kbps@44.1kHz).
 - 🔑 The AVRCP feature is supported. It's functionality will differ, depending on the specifications of the connected device.
 - 🔑 Connect only to a Bluetooth device that supports the A2DP Profile.
 - 🔑 Only one Bluetooth device can be paired at a time. The search or connection functions may not work properly in the following cases:
 - If there a strong electric field near or around the home theater.
 - If several Bluetooth devices are simultaneously paired with product.

- If the Bluetooth device is turned off, not in place, or malfunctions.

Note that such devices as microwave ovens, wireless LAN adapters, fluorescent lights, and gas stoves use the same frequency range as the Bluetooth device, and can cause electric interference.

- ✎ For the best operational compatibility between the home theater and a Bluetooth device or any other device, such as a Mobile Phone, we recommend you update the device's OS to the latest version.

To Disconnect the Bluetooth Device from the Home Theater

You can disconnect the Bluetooth device from the Home Theater. For instructions, refer to the Bluetooth device's manual.

- When the Home Theater is disconnected from the Bluetooth device, the Home Theater will display **DISCONNECTED** on the front display.

To Disconnect the Home Theater from the Bluetooth Device

Press the () button on the front panel of the Home Theater to switch from **BT** to another mode or turn off the Home Theater.

- Except when you disconnect the Home Theater by changing functions, the connected Bluetooth device will wait a certain amount of time for a response from the Home Theater before terminating the connection. (Disconnection time may differ, depending on the Bluetooth device.)
- ✎ In Bluetooth connection mode, the Bluetooth connection will be lost if the distance between the Home Theater System and the Bluetooth device exceeds 10 meters. When the Bluetooth device comes back into effective range or you restart the Bluetooth device, you will have to pair the device and home theater again to reconnect.
- ✎ In Bluetooth mode, the screen saver will start if the Bluetooth device stays in the Ready state for 5 minutes. To reconnect the Bluetooth device, turn off the screen saver, and then connect the device. To turn off the screen saver, press any button on the remote control (the Volume button, a number button, etc.)

Using the Bluetooth Quick Start

When the home theater is turned off, connecting your smart device to the product via a Bluetooth connection can turn the home theater on.

- ✎ The **Quick Start** function is available when the home theater's power cord is plugged into an AC wall outlet.
 - ✎ To use this function, set **Settings > System > Quick Start to On**.
 - ✎ To use this function, the Bluetooth connection between the home theater and your smart device should have been established before. In other words, the home theater should be found on the list of Bluetooth devices your smart device has already connected to.
1. Connect your smart device to the product via Bluetooth. (For information on Bluetooth connections, refer to your smart device's manual.)
 2. Once connected, the home theater will turn itself on automatically in BT mode.
 - Select the desired music to play on your smart device.

Using the Special Effects Remote Control Buttons

TV SOUND



If you have a TV that supports Anynet+ (HDMI-CEC), the **TV SOUND** button lets you direct the TV's audio to the Home Theater Speakers or the TV Speakers. To use this function, follow these steps:

1. Connect an HDMI cable to the TV and home theater. (See page 11)
2. Set **Anynet+ (HDMI-CEC) On** in the home theater and TV.
3. Press the **TV SOUND** button on the remote control. **TV SOUND ON** flashes on the display on the front panel, and then changes to **D. IN.**
 - When TV SOUND is on, TV audio outputs through the Home Theater speakers.
4. Press the **TV SOUND** button again to turn TV SOUND off.
 - When TV SOUND is off, TV audio outputs through the speakers of the connected Anynet+ TV.

Playing Content

□ **Use TV SOUND:**

- 1) When you want to listen to the TV's audio through the home theater speakers.
- 2) When you want to listen to the audio from a USB device plugged into the TV through the home theater speakers.

□ **TV SOUND ON/OFF support specifications:**

Anynet+ (HDMI-CEC) Setting	TV Sound ON	TV Sound OFF
ON	HTS Speaker Output	HTS Speaker Mute
	TV Speaker Mute	TV Speaker Output
OFF	HTS Speaker Output	HTS Speaker Mute
	TV Speaker Output	TV Speaker Output
No Operation	HTS Speaker Output	HTS Speaker Mute
	TV Speaker Output	TV Speaker Output

DSP/EQ	
--------	---

You can adjust the sound with various sound modes.





- ↓ **DSP OFF** : Select for normal listening.
- ↓ **CINEMA** : Produces realistic and powerful sound for movies.
- ↓ **MUSIC** : Suitable for all music sources.
- ↓ **GAME** : Revs up video games with powerful and realistic sound.
- ↓ **M-STEREO (Multi Stereo)** : Produces surround sound from 2 channel input sources.
- ↓ **POWER BASS** : Pumps up the bass sound.
- ↓ **LOUD** : Improves bass sound characteristics according to output level.
- ↓ **NIGHT** : Optimizes sound for night time listening by compressing the dynamic range and softening the sound.
- ↓ **USER EQ** : Provides a user adjustable equalizer so you can adjust music to your liking.
- ↓ **LOCAL EQ** : It provides a unique EQ curve for fitting to local music.

Network Services

Using BD-LIVE™

1. Connect the product to your network.
(See page 12)
2. Configure the network settings.
(See pages 19~21)

Once the product is connected to your network, you can enjoy various movie-related service contents available on BD-LIVE compliant discs.

1. Attach a USB memory stick to the USB jack on the front of the product, and then use **BD Data Management** to check its remaining memory. The memory device must have at least 1GB of free space to accommodate the BD-LIVE services.
2. Select **Settings** on the Home screen, and then press the  button.
3. Select **System**, and then press the  button.
4. Select **BD Data Management**, and then press the  button.
5. Select **Change Device**, and then press the  button.
6. Select **STORAGE DEVICE**, and then press the  button.
7. Insert a Blu-ray Disc that supports BD-LIVE.
8. Select an item from the list of BD-LIVE service contents provided by the disc manufacturer.

 The way you use BD-LIVE and the provided contents may differ, depending on the disc manufacturer.











Using DLNA

DLNA lets you access and play files located on your PC through your home theater.

Follow the directions in the DLNA user's guide to set up DLNA on your PC and to tag folders and files you want to share with the home theater.

To access and play files located on your PC after you have set up DLNA, follow these steps:

1. Turn on your PC, your TV, and the home theater.
2. Make sure the DLNA Shared server is running on your PC.

3. On your home theater, select **Change Device**.
 4. Use the   button to select your PC in the Device List.
 5. Select the kind of file you want to view or play, **PHOTOS**, **VIDEOS**, or **MUSIC** and then press .
 6. Use the   button to select the folder with the kind of files you selected, and then press .
 7. Select the file you want to view or play, and then press .
-  You can create Playlists from files on your PC in the same way you create playlists from files on USB devices and discs.
-  With a few exceptions, you can control the playback of files on your PC in the same fashion you control the playback of files on USB devices and discs.
-  You can also access files on your PC by first selecting **PHOTOS**, **VIDEOS**, or **MUSIC** on the Home screen, and then selecting your PC from the device list that appears.

Apps

Your home theater offers an extensive collection of news, movies, weather, and other content you can download directly to and enjoy on your home theater. First, check the network and make sure the home theater is connected to the Internet. Your home theater must be connected to the Internet to use the Apps feature.

The apps offered through the Apps feature work much like their on-line versions or, if different, are easy to use.

Some apps require you to create an account before you can use them. Although you can create an account for most of these apps through your home theater, it is easier and quicker to create an account by visiting the app sites on line using a PC, laptop, or tablet with Internet access. Note that in some cases, you will need to use the home theater and a PC, laptop, or tablet to establish an account. The main difference between the regular on-line versions and the versions you can access through your home theater is that with the home theater versions, you use your remote to enter letters and numbers as opposed to a keyboard.

Network Services

Using Apps

The first time you access any one of the apps, the home theater displays two agreements. You must accept both agreements to download and use any apps.









By default, the home theater displays four popular apps on the Home screen. You can view more apps and change the apps the home theater displays on the Home screen by selecting the **More** button.

To start an app, highlight the app, double click it, and then follow the directions displayed on the screen.

Viewing Additional Apps

1. Select the **More** button on the Home screen, and then press the  button. The More Apps screen appears displaying a bank of apps.
2. To view additional apps, move the highlight to the right or left until another group of apps appears.
3. To exit the More Apps screen, select **Close** or press the **RETURN** button or **EXIT** button on your remote.

Changing the Apps Displayed on the Home Screen

1. Select the **More** button, and then press the  button.
 2. Select the **Edit** button on the More Apps screen, and then press the  button.
 3. Apps that the home theater displays on the Home page are marked with a check. Deselect apps you want to remove from the Home screen by highlighting each app, and then pressing the  button.
 4. Select apps by highlighting each app, and then pressing the  button. A check mark appears on each app you select. You can have up to four apps selected at a time.
 5. When done, select **OK**, and then press the  button. The Home screen re-appears.
-  To exit an application, press the **EXIT** button on your remote.
-  To delete the login information for all Apps, press the  button for 5 seconds or more in Home Screen, No Disc Status.

Using Opera TV Store

At the **Opera TV Store**, you will find high-quality Internet video streaming, social network, and music streaming services.

Accessing Opera TV Store

To access **Opera TV Store**, select the **Opera TV Store** button on the Home screen, and then press the  button.

To exit the **Opera TV Store** screen, press the **EXIT** button on your remote.

Navigating in Opera TV Store

When the **Opera TV Store** screen appears, it displays a bank of assorted apps. Use the **▲▼◀▶** buttons on your remote to move the highlight from app to app.

Selecting an App

Move the highlight to the app you want, and then press the  button.

In the pop-up that appears, select **OPEN** to open the app immediately or **ADD TO MY APPS** to add the app to **MY APPS**. Press the **RETURN** button on your remote to go back to the **Opera TV Store** screen.

Selecting Apps by Category





To make searching for apps easier, you can view apps by categories such as **New**, **Popular**, **All**, **Games**, **Music**, etc.

To select a category, use the **▲** button on your remote to move the highlight to the top of the screen. Then, use the **◀▶** buttons to select a category.



Using the My Apps Screen

To access the **My Apps** screen, highlight **MY APPS**, and then press the  button. The **My Apps** screen appears displaying all the apps you have saved with the **MY APPS** designation.

Deleting Apps from MY APPS



1. Highlight the **MENU** button on the top of the **My Apps** screen, and then press the  button on your remote.
2. Select **REMOVE APPS** in the menu, and then press the  button. A red rectangle appears around one of the apps.
3. Move the rectangle to the app you want to delete, and then press the  button.
4. Repeat this process to delete additional apps.
5. When finished, select **DONE**, and then press the  button.
6. Press the **RETURN** button to go back to the Main screen.

Searching for Apps

1. Select **SEARCH** at the top of the screen, and then press the  button.
2. To search quickly for popular items, click one of the popular search tabs at the top of the screen.
3. To search for an app by name, enter the app name using the onscreen keyboard. **Opera TV Store** will search as you type and display apps with names that match the letters you enter.
 - To cancel a current search, press the **RETURN** button on your remote or select **BACK** on the screen, and then press .

Screen Mirroring

Screen Mirroring lets you display the screen of a smart phone or other compatible device on the TV screen using Miracast™ technology. Screen Mirroring does not require a cable or a wireless router.

1. From the Home screen, use the   buttons to select **Screen Mirroring**, and then press .
2. Launch AllShare Cast on your smart phone or device.
3. On your device, find the name of the home theater system in the list of available devices, and then select it.

4. The TV displays a connecting message (for example, Connecting to Android_92gb...) and then displays the connected message.
5. In a few moments, the screen of your device appears on the TV screen.
 - When you are using the **Screen Mirroring** function, video stuttering or audio dropouts may occur, depending on your environment.
 - The Home Theater can connect to devices that support AllShare Cast. Note that all devices that have AllShare Cast may not be fully supported, depending on the manufacturer. For further information on mobile connection support, refer to the manufacturer's web site.
 - Bluetooth transmissions can interfere with the **Screen Mirroring** signal. Before using the **Screen Mirroring** function, we strongly recommend that you turn off the Bluetooth function on your smart phone or smart device.

Additional Information

Notes

Connections

HDMI OUT

- Certain HDMI output resolutions may not work, depending on your TV.
- You must have an HDMI connection to enjoy videos with 3D technology.
- A long HDMI cable may cause screen noise. If this occurs, set **HDMI Deep Color** to **Off** in the menu.

Settings

3D Settings

- For some 3D discs, to stop a movie during 3D playback, press the **□** button once. The movie stops and the 3D mode option is de-activated. To change a 3D option selection when you are playing a 3D movie, press the **□** button once. The Blu-ray menu appears. Press the **□** button again, then select **3D Settings** in the Blu-ray menu.
- Depending on the content and the position of the picture on your TV screen, you may see vertical black bars on the left side, right side, or both sides.

TV Aspect Ratio

- Depending on the disc type, some aspect ratios may not be available.
- If you select an aspect ratio and option which is different than the aspect ratio of your TV screen, the picture might appear to be distorted.
- If you select **16:9 Original**, your TV may display **4:3 Pillarbox** (black bars on the sides of the picture).

BD Wise (Samsung Products only)

- When **BD Wise** is on, the **Resolution** setting automatically defaults to **BD Wise** and **BD Wise** appears in the **Resolution** menu.
- If the product is connected to a device that does not support **BD Wise**, you cannot use the **BD Wise** function.
- For proper operation of **BD Wise**, set the **BD Wise** option in both the product and the TV to **On**.

Digital Output

- Be sure to select the correct **Digital Output** or you will hear no sound or just loud noise.
- If the HDMI device (AV receiver, TV) is not compatible with compressed formats (Dolby Digital, DTS), the audio signal outputs as PCM.
- Regular DVDs do not have **BONUSVIEW** audio and **Navigation Sound Effects**.
- Some Blu-ray Discs do not have **BONUSVIEW** audio and **Navigation Sound Effects**.
- This **Digital Output** setup does not affect the analog (L/R) audio or HDMI audio output to your TV. It affects the optical and HDMI audio output when your product is connected to an AV receiver.
- If you play MPEG audio soundtracks, the audio signal outputs as PCM regardless of your **Digital Output** selections (PCM or Bitstream).
- **Digital Output** can be activated when **Speaker Selection** is set to **TV Speaker**.

BD-Live Internet Connection

- The Internet connection may be restricted while you are using BD-LIVE contents.

Anynet+ (HDMI-CEC)

- Depending on your TV, certain HDMI output resolutions may not work. Please refer to the user manual of your TV.
- This function is not available if the HDMI cable does not support CEC.
- If your Samsung TV has an Anynet+ logo, then it supports the Anynet+ function.

BD Data Management

- In the external memory mode, disc playback may be stopped if you disconnect the USB device in the middle of playback.
- Only those USB devices formatted in the FAT file system (DOS 8.3 volume label) are supported. We recommend you use USB devices that support the USB 2.0 protocol with 4 MB/sec or faster read/write speeds.
- The **Resume Play** function may not work after you format the storage device.
- The total memory available to **BD Data Management** may differ, depending on conditions.

DivX® Video On Demand

- For more information about DivX(R) VOD, visit "<http://vod.divx.com>".

Speaker Settings

- When **Speaker Selection** is set to **TV Speaker**, audio is produced by the TV speakers.

HDMI audio

- When HDMI audio is output to the TV speakers, it is automatically down-mixed to 2 channels.

Audio Return Channel

- When **Anynet+ (HDMI-CEC)** is **Off**, the **Audio Return Channel** function is not available.
- Using an HDMI cable not certified for ARC (Audio Return Channel) may cause a compatibility problem.
- The ARC function is only available if an ARC-compliant TV is connected.

Playback

Playing Video files

- Video files with high bitrates of 20Mbps or more strain the product's capabilities and may stop playing during playback.

Selecting the Audio Language

- The ◀▶ indicator will not appear on the screen if the **BONUSVIEW** section does not contain any **BONUSVIEW** audio settings.
- The languages available through the **Audio Language** function depend on the languages that are encoded on the disc. This function or certain languages may not be available.
- Some Blu-ray Discs may allow you to select either the **PCM** or **Dolby Digital** audio English soundtrack.

Selecting the Subtitle Language

- Depending on the Blu-ray Disc / DVD, you may be able to change the subtitle language in the **Disc Menu**. Press the **DISC MENU** button.
- This function depends on the selection of subtitles that are encoded on the disc and may not be available on all Blu-ray Discs/DVDs.
- Information about the main feature **BONUSVIEW** mode will also appear if the Blu-ray Disc has a **BONUSVIEW** section.
- This function changes both the primary and secondary subtitles at the same time.
- The total number of primary and secondary subtitles, respectively, is displayed.

Playing JPEG files

- You can't enlarge the subtitle and PG graphics in the full screen mode.

Playing Content

Using the TOOLS button while playing pictures

- If the home theater is connected to a **BD Wise** compliant TV that has **BD Wise On**, the **Picture Settings** menu will not appear.
- The **Background Music** function will not work unless the music file and the photo file are located on the same storage media. Also, sound quality can be impacted by the bitrate of the MP3 music file, the size of the photos, and the encoding method.

Disk and Format Compatibility

Disc types and content your Product can Play

Media	Disc Type	Details
VIDEO	Blu-ray Disc 3D Blu-ray Disc	BD-ROM or BD-RE/-R disc recorded in the BD-RE format.
	DVD-VIDEO, DVD-RW, DVD-R, DVD+RW, DVD+R VCD 1.1	DVD-VIDEO, recorded DVD+RW/DVD-RW(V)/DVD-R/+R discs that have been recorded and finalized, or a USB storage media containing DivX, MKV, MP4, VCD 1.1 contents.
MUSIC	CD-RW/-R, DVD-RW/-R, BD-RE/-R	Music recorded on CD-RW/-R, DVD-RW/-R, BD-RE/-R discs or a USB storage media containing MP3 or WMA contents.
PHOTO	CD-RW/-R, DVD-RW/-R, BD-RE/-R	Photos recorded on CD-RW/-R, DVD-RW/-R, BD-RE/-R discs or a USB storage media containing JPEG contents.

-  The product may not play certain CD-RW/-R and DVD-R because of the disc type or recording conditions.

Appendix









- 📎 If a DVD-RW/-R disc has not been recorded properly in DVD video format, it will not be playable.
- 📎 Your product will not play content that has been recorded on a DVD-R at a bitrate that exceeds 10 Mbps.
- 📎 Your product will not play content that has been recorded on a BD-R or USB device at a bitrate that exceeds 30 Mbps.
- 📎 Playback may not work for some types of discs, or when you use specific operations, such as angle change and aspect ratio adjustment. Information about the discs is written in detail on the disc box. Please refer to this if necessary.
- 📎 When you play a BD-J title, loading may take longer than a normal title or some functions may perform slowly.

Disc Types your Product cannot Play

- HD DVD
- DVD-ROM/PD/MV-Disc, etc
- DVD-RW(VR mode)
- CVD/CD-ROM/CDV/CD-G/CD-I/LD (CD-Gs play audio only, not graphics.)
- DVD-RAM
- Super Audio CD (except CD layer)
- 3.9 GB DVD-R Disc for Authoring.



- 📎 This product may not respond to all operating commands because some Blu-ray Disc, DVD, and CD discs allow specific or limited operation and provide only certain features during playback. Please note that this is not a defect in the product.
- 📎 Samsung cannot guarantee that this product will play every disc bearing the Blu-ray Disc, DVD, or CD logo because disc formats evolve, and problems and errors may occur during the creation of Blu-ray Disc, DVD, and CD software and/or the manufacture of discs.
- 📎 Please contact the SAMSUNG Customer Care Center at, if you have questions or encounter difficulty when playing Blu-ray Discs, DVD, or CD discs in this product. Also, refer to the rest of this user manual for additional information on playback restrictions.
- 📎 Some commercial discs and DVD discs purchased outside your region may not play on this product.

Logos of Discs the Product can Play

	
Blu-ray Disc	3D Blu-ray Disc
	
BD-LIVE	Dolby
	
DTS	Java
	
PAL broadcast system in U.K, France, Germany, etc.	DivX

Region Code

Both products and discs are coded by region. These regional codes must match for a disc to play. If the codes do not match, the disc will not play. The Region Number for this product is displayed on the rear panel of the product.

Disc Type	Region Code	Area
Blu-ray Disc		North America, Central America, South America, Korea, Japan, Taiwan, Hong Kong and South East Asia.
		Europe, Greenland, French territories, Middle East, Africa, Australia and New Zealand.
		India, China, Russia, Central and South Asia.

DVD-VIDEO		The U.S., U.S. territories and Canada
		Europe, Japan, the Middle East, Egypt, Africa, Greenland
		Taiwan, Korea, the Philippines, Indonesia, Hong Kong
		Mexico, South America, Central America, Australia, New Zealand, Pacific Islands, Caribbean
		Russia, Eastern Europe, India, North Korea, Mongolia
		China

 If the Region number of a Blu-ray Disc/DVD does not correspond to the Region number of this product, the product cannot play the disc.

AVCHD (Advanced Video Codec High Definition)

- This product can play back AVCHD format discs. These discs are normally recorded and used in camcorders.
- The AVCHD format is a high definition digital video camera format.
- The MPEG-4 AVC/H.264 format compresses images with greater efficiency than the conventional image compressing format.
- Some AVCHD discs use the "x.v.Color" format. This product can play back AVCHD discs that use the "x.v.Color" format.
- "x.v.Color" is a trademark of Sony Corporation.
- "AVCHD" and the AVCHD logo are trademarks of Matsushita Electronic Industrial Co., Ltd. and Sony Corporation.

 Some AVCHD format discs may not play, depending on the recording conditions.

 AVCHD format discs need to be finalized.

 "x.v.Color" offers a wider color range than normal DVD camcorder discs.

 Some DivX, MKV and MP4 format discs may not play, depending on their video resolution and frame rate.

Supported Formats

Notes on the USB connection

- Your product supports USB storage media, MP3 players, digital cameras, and USB card readers.
- The product does not support folder or file names longer than 128 characters.
- Some USB/digital camera devices may not be compatible with the product.
- Your product supports the FAT 16, FAT 32, and NTFS file systems.
- Connect USB devices directly to the product's USB port. Connecting through a USB cable may cause compatibility problems.
- Inserting more than one memory device into a multi-card reader may cause the reader to operate improperly.
- The product does not support the PTP (Peer to Peer) protocol.
- Do not disconnect a USB device while it is transferring or recording data.
- The bigger the image resolution, the longer the image takes to display.
- This product cannot play MP3 files with DRM (Digital Rights Management) downloaded from commercial sites.
- Your product only supports video that is under 30fps (frames per second).
- Your product only supports USB Mass Storage Class (MSC) devices such as thumb drives and USB HDD. (HUB is not supported.)
- Certain USB HDD Devices, multi-card readers and thumb drives may not be compatible with this product.
- If some USB devices require excessive power, they may be limited by the circuit safety device.
- If playback from a USB HDD is unstable, provide additional power by plugging the HDD into a wall socket. If the problem continues, contact the USB HDD manufacturer.
- SAMSUNG is not responsible for any data file damage or data loss.

Appendix

Video File Support

File Extension	Container	Video Codec	Audio Codec	Resolution
*.avi	AVI	DivX 3.11/4/5/6 MP4v3 H.264 BP/MP/HP	MP3, Dolby Digital, DTS, WMA, PCM	1920x1080
*.mkv	MKV	VC-1 AP, DivX 5/6 H.264 BP/MP/HP	MP3, Dolby Digital, DTS	
*.wmv	WMV (wmv9)	VC-1 AP VC-1 SM	WMA	
*.mp4	MP4	MP4 (mp4v) H.264 BP/MP/HP	AAC	
*.mpg / *.mpeg	PS	MPEG1 MPEG2 H.264 BP/MP/HP	MP1, 2 Dolby Digital, DTS	

■ Limitations

- Even when a file is encoded by a supported codec listed above, the file might not play if its content has a problem.
- Normal playback is not guaranteed if the file's container information is wrong or the file itself is corrupted.
- Files having a higher bitrate/frame rate than standard may stutter during sound/video playback.
- The Seek (skip) function is not available if the file's index table is damaged.

■ Video decoder

- Supports up to H.264 Level 4.1 and AVCHD
- Does not support H.264 FMO/ASO/RS and VC1 SP/MP/AP L4
- MPEG4 SP, ASP :
Below 1280 x 720 : 60 frames max
Above 1280 x 720 : 30 frames max
- Does not support GMC 2 or higher

■ Audio decoder

- Supports WMA 7, 8, 9 and STD
- Does not support WMA sampling rate of 22050Hz mono.
- AAC: Max sampling rate: 96Khz (8, 11, 12, 16, 22,24, 32,44.1, 48, 64, 88.2, 96) Max bitrate: 320kbps

■ Supported DivX subtitle file formats

- *.txt, *.smi, *.srt, *.sub, *.txt

Music File Support

File Extension	Container	Audio Codec	Support Range
*.mp3	MP3	MP3	-
*.wma	WMA	WMA	* Sampling rates (in kHz) - 8, 11, 16, 22, 32, 44.1, 48 * Bitrates - All bitrates from 5kbps to 384kbps

Picture File Support

File Extension	Type	Resolution
*.jpg / *.jpeg / *.jpe	JPEG	15360x8640
*.png	PNG	

Digital Output Selections

Setup		PCM	Bitstream (Unprocessed)	Bitstream (Re-encoded DTS)	Bitstream (Re-encoded Dolby D)
Connection		HDMI supported AV receiver			
Audio Stream on Blu-ray Disc	PCM	Up to PCM 7.1 ch	PCM	DTS re-encoded	Re-encoded Dolby Digital *
	Dolby Digital	Up to PCM 5.1 ch	Dolby Digital		
	Dolby Digital Plus		Dolby Digital Plus		
	Dolby TrueHD		Dolby TrueHD		
	DTS		DTS		
	DTS-HD High Resolution Audio		DTS-HD High Resolution Audio		
	DTS-HD Master Audio		DTS-HD Master Audio		
Audio Stream on DVD	PCM	PCM 2ch			
	Dolby Digital	Up to PCM 5.1 ch	Dolby Digital		
	DTS		DTS		
Definition for Blu-ray Disc	Any	Decodes the main feature audio and BONUSVIEW audio stream together into PCM audio and adds Navigation Sound Effects.	Outputs only the main feature audio stream so that your AV receiver can decode the audio bitstream. You will not hear BONUSVIEW audio or Navigation Sound Effects.	Decodes the main feature audio and BONUSVIEW audio stream together into PCM audio and adds Navigation Sound Effects, then re-encodes the PCM audio into DTS bitstream.	Decodes the main feature audio and BONUSVIEW audio stream together into PCM audio and adds Navigation Sound Effects, then re-encodes the PCM audio into Dolby Digital bitstream or PCM.

- If the Source Stream is 2ch or mono, "Re-encoded Dolby D" Setting are not applied. Output will be PCM 2ch.

Blu-ray Discs may include three audio streams :

- Main Feature Audio : The audio soundtrack of the main feature.
- BONUSVIEW audio : An additional soundtrack such as the director or actor's commentary.
- Navigation Sound Effects : When you choose some menu navigation options, Navigation Sound Effects may sound. Navigation Sound Effects are different on each Blu-ray Disc.



Appendix

Resolution according to the output mode

Blu-ray Disc/E-contents/Digital Contents playback			DVD playback
Setup	Output	HDMI Mode	
		Blu-ray Disc	E-contents/ Digital contents
BD Wise	Resolution of Blu-ray Disc	1080p@60F	576i/480i
Auto	Max. Resolution of TV input		Max. Resolution of TV input
1080p@60F	1080p@60F		-
1080p	-		1080p
Movie Frame : Auto (24Fs)	1080p@24F		-
1080i	1080i		1080i
720p	720p		720p
576p/480p	576p/480p		576p/480p

Troubleshooting

Refer to the table below when this product does not function properly. If the problem you are experiencing is not listed below or if the instructions below do not help, turn off the product, disconnect the power cord and contact the nearest authorized dealer or Samsung Electronics Service Center.

Symptom	Check/Remedy
You cannot eject the disc.	<ul style="list-style-type: none"> Is the power cord plugged securely into the outlet? Turn off the power, and then turn it back on.
Playback does not start.	<ul style="list-style-type: none"> Check the region number of the Blu-ray/DVD disc. A Blu-ray/DVD disc purchased from abroad may not be playable. CD-ROMs and DVD-ROMs cannot be played on this product. Make sure that the rating level is correct.
Playback does not start immediately when you press the /  button.	<ul style="list-style-type: none"> Are you using a deformed disc or a disc with scratches on the surface? Wipe the disc clean.
No sound.	<ul style="list-style-type: none"> The home theater does not play sound during fast playback, slow playback, and step motion playback. Are the speakers connected properly? Is the speaker setup correctly customized? Is the disc severely damaged?
You can only hear sound from a few speakers, but not all 6.	<ul style="list-style-type: none"> On certain Blu-ray/DVD discs, sound is output from the front speakers only. Check if the speakers are connected properly. Adjust the volume. When playing audio from a CD, the radio, or a TV, the unit outputs sound to the front speakers only.

Symptom	Check/Remedy
Dolby Digital 5.1 CH Surround Sound is not produced.	<ul style="list-style-type: none"> Is there "Dolby Digital 5.1 CH" mark on the disc? Dolby Digital 5.1 CH Surround Sound is produced only if the disc is recorded with 5.1 channel sound. Is the audio language correctly set to Dolby Digital 5.1-CH in the information display?
The remote control does not work.	<ul style="list-style-type: none"> Are you operating the remote within its operational range and within the proper angle relative to the sensor? Are the batteries drained? Have you selected the correct mode? Press the function button to change the mode (BD/DVD, D. IN, AUX, etc.)
<ul style="list-style-type: none"> The disc is rotating but there is no picture. Picture quality is poor and the picture is shaking. 	<ul style="list-style-type: none"> Is the TV power on? Are the video cables connected properly? Is the disc dirty or damaged? A poorly manufactured disc may not be playable.
Audio language and subtitles do not work.	<ul style="list-style-type: none"> The Audio Language and subtitle functions will not work if the disc does not contain multiple language sound tracks or subtitles.
The menu screen does not appear even when you select the menu function.	<ul style="list-style-type: none"> Are you using a disc that does not contain menus?
The aspect ratio cannot be changed.	<ul style="list-style-type: none"> The home theater can play 16:9 Blu-ray/DVD discs in 16:9 Full mode, 4:3 Letter Box mode, or 4:3 Pan-Scan mode, but plays 4:3 Blu-ray/DVD discs in 4:3 mode only. Refer to the Blu-ray Disc jacket, and then select the appropriate aspect ratio.
<ul style="list-style-type: none"> The product is not working. (Example: The power goes off or you hear a strange noise.) The Product is not working normally. 	<ul style="list-style-type: none"> Press and hold the remote control's RESET button for 5 seconds in STANDBY mode. This will reset the unit. <ul style="list-style-type: none"> Using the RESET function will erase all stored settings. Do not use this function unless necessary.
You have forgotten the rating level password.	<ul style="list-style-type: none"> With no disc in the product, press and hold the product's RESET button for longer than 5 seconds. INIT appears on the display and all settings will return to their default values. <ul style="list-style-type: none"> Using the RESET function will erase all stored settings. Do not use this function unless necessary.
Can't receive radio broadcasts.	<ul style="list-style-type: none"> Is the antenna connected properly? If the antenna's input signal is weak, install an external FM antenna in an area with good reception.
There is no sound when you try to listen to TV audio through the home theater speakers.	<ul style="list-style-type: none"> If you press the TV button while listening to TV audio using the D. IN or AUX functions, the Blu-ray/DVD disc functions are turned on and the TV audio is muted.

Appendix

Symptom	Check/Remedy
"Not Available" appears on screen.	<ul style="list-style-type: none"> The feature is unavailable or the action cannot be completed at this time because: <ol style="list-style-type: none"> The Blu-ray/DVD disc's software restricts it. The Blu-ray/DVD disc's software doesn't support the feature (e.g., angles) The feature is not available at the moment. You've requested a title or chapter number or search time that is out of range.
If the HDMI output is set to a resolution your TV cannot support (for example, 1080p), you may not see a picture on your TV.	<ul style="list-style-type: none"> Press and hold the □ button on front panel for more than 5 seconds with no disc in the product. All settings will revert to their factory settings.
No HDMI output.	<ul style="list-style-type: none"> Check the connection between the TV and the HDMI jack of the product. Check if your TV supports 576p/480p/720p/1080i/1080p HDMI input resolution.
Abnormal HDMI output appears on the screen.	<ul style="list-style-type: none"> If random noise appears on the screen, it means that TV does not support HDCP (High-bandwidth Digital Content Protection).
DLNA function	
You can see folders shared through DLNA, but cannot see the files.	<ul style="list-style-type: none"> DLNA shows only Photo, Music, and Movie files. It does not display other kinds of files.
Video plays intermittently.	<ul style="list-style-type: none"> Check if the network is stable. Check if the network cable is properly connected and if the network is overloaded.
The DLNA connection between the TV and PC is unstable.	<ul style="list-style-type: none"> IP addresses under the same subnetwork should be unique, otherwise IP collision can cause an unstable connection. Check if you have a firewall enabled. If so, disable the firewall function.
BD-LIVE	
The home theater cannot connect to the BD-LIVE server.	<ul style="list-style-type: none"> Test whether the network connection is active by using the Network Status function. Check whether a USB memory device is connected to the product. The memory device must have at least 1GB of free space to accommodate the BD-LIVE service. You can check the available size in BD Data Management. (See pages 35 and 38.) See if the BD-Live Internet Connection option is set to Allow(All). If all above fails, contact the content provider or update to the latest firmware.
When using the BD-LIVE service, an error occurs.	<ul style="list-style-type: none"> The USB memory device must have at least 1GB of free space to accommodate the BD-LIVE service. You can check the available size in BD Data Management. (See pages 35 and 38.)

 When the factory default settings are restored, all stored user BD data is deleted.

Specifications

General	Weight	1.90 kg			
	Dimensions	430.0 (W) x 55.0 (H) x 224.0 (D) mm			
	Operating Temperature Range	+5°C to +35°C			
	Operating Humidity Range	10 % to 75 %			
FM Tuner	Signal/noise ratio	55 dB			
	Usable sensitivity	12 dB			
	Total harmonic distortion	1.0 %			
HDMI	Video	1080p, 1080i, 720p, 576p/480p			
	Audio	PCM multichannel audio, Bitstream audio, PCM audio			
Amplifier	Front speaker output	165W x 2 (3Ω)			
	Center speaker output	170W (3Ω)			
	Surround speaker output	165W x 2 (3Ω)			
	Subwoofer speaker output	170W (3Ω)			
	Frequency response	20Hz~20kHz (±3dB)			
	S/N Ratio	70dB			
	Channel separation	60dB			
	Input sensitivity	(AUX) 500mV			
Speaker (5.1ch speaker system)					
Speaker system	Impedance	Frequency range	Rated input	Dimensions (W x H x D) (mm)	Weights (kg)
Front	3 Ω	200Hz ~ 20kHz	165W	83.4 x 1053.0 x 101.0 (Stand base: Ø255.0)	3.15
Surround				83.4 x 1053.0 x 101.0 (Stand base: Ø255.0)	2.98
Center		20Hz ~ 200Hz	170W	268.8 x 87.6 x 101.0	0.58
Subwoofer				220.6 x 380.6 x 364.7	6.50

- 🔌 Network speeds equal to or below 10Mbps are not supported.
- 🔌 Samsung Electronics Co., Ltd reserves the right to change the specifications without notice.
- 🔌 Weight and dimensions are approximate.
- 🔌 Design and specifications are subject to change without prior notice.
- 🔌 For the power supply and Power Consumption, refer to the label attached to the product.
- 🔌 For India Only
"This product is RoHS compliant"

Licenses



Manufactured under license from Dolby Laboratories. Dolby and the double-D symbol are trademarks of Dolby Laboratories.



For DTS patents, see <http://patents.dts.com>. Manufactured under license from DTS Licensing Limited. DTS, DTS-HD, the Symbol, & DTS and the Symbol together are registered trademarks, and DTS-HD Master Audio | Essential is a trademark of DTS, Inc. © DTS, Inc. All Rights Reserved.



This DivX Certified® device has passed rigorous testing to ensure it plays DivX® video. To play purchased DivX movies, first register your device at vod.divx.com. Find your registration code in the DivX VOD section of your device setup menu.

DivX Certified® to play DivX® video up to HD 1080p, including premium content.

DivX®, DivX Certified® and associated logos are trademarks of DivX, LLC and are used under license.

Covered by one or more of the following U.S. patents: 7,295,673; 7,460,668; 7,515,710; 7,519,274.



DLNA®, the DLNA Logo and DLNA CERTIFIED® are trademarks, service marks, or certification marks of the Digital Living Network Alliance.



The terms HDMI and HDMI High-Definition Multimedia Interface, and the HDMI Logo are trademarks or registered trademarks of HDMI Licensing LLC in the United States and other countries.



Oracle and Java are registered trademarks of Oracle and/or its affiliates. Other names may be trademarks of their respective owners.

This item incorporates copy protection technology that is protected by U.S. patents and other intellectual property rights of Rovi Corporation. Reverse engineering and disassembly are prohibited.

Blu-ray Disc™, Blu-ray™, and the logos are trademarks of Blu-ray Disc Association.

This product uses Cinavia technology to limit the use of unauthorized copies of some commercially-produced film and videos and their soundtracks. When a prohibited use of an unauthorized copy is detected, a message will be displayed and playback or copying will be interrupted.

More information about Cinavia technology is provided at the Cinavia Online Consumer Information Center at <http://www.cinavia.com>. To request additional information about Cinavia by mail, send a postcard with your mailing address to: Cinavia Consumer Information Center, P.O. Box 86851, San Diego, CA, 92138, USA."

This product incorporates proprietary technology under license from Verance Corporation and is protected by U.S. Patent 7,369,677 and other U.S. and worldwide patents issued and pending as well as copyright and trade secret protection for certain aspects of such technology. Cinavia is a trademark of Verance Corporation. Copyright 2004-2010 Verance Corporation. All rights reserved by Verance. Reverse engineering or disassembly is prohibited.

- Open Source License Notice

In the case of using open source software, Open Source Licenses are available on the product menu.



Contact SAMSUNG WORLD WIDE

If you have any questions or comments relating to Samsung products, please contact the SAMSUNG customer care center.

Area	Contact Centre ☎	Web Site
■ Asia Pacific		
CHINA	400-810-5858	www.samsung.com/cn/support
HONG KONG	(852) 3698 4698	www.samsung.com/hk/support (Chinese) www.samsung.com/hk_en/support (English)
MACAU	0800 333	www.samsung.com/support
SINGAPORE	1800-SAMSUNG(726-7864)	www.samsung.com/sg/support
AUSTRALIA	1300 362 603	www.samsung.com/au/support
NEW ZEALAND	0800 726 786	www.samsung.com/nz/support
VIETNAM	1800 588 889	www.samsung.com/vn/support
THAILAND	0-2689-3232, 1800-29-3232	www.samsung.com/th/support
MYANMAR	+95-01-2399-888	www.samsung.com/support
MALAYSIA	1800-88-9999 603-77137477 (Overseas contact)	www.samsung.com/my/support
INDONESIA	021-56997777 08001128888	www.samsung.com/id/support
PHILIPPINES	1-800-10-7267864 [PLDT] 1-800-8-7267864 [Globe landline and Mobile] 02-4222111 [Other landline]	www.samsung.com/ph/support
TAIWAN	0800-329999	www.samsung.com/tw/support
JAPAN	0120-363-905	www.samsung.com/jp/support
INDIA	1800 3000 8282 - Toll Free 1800 266 8282 - Toll Free	www.samsung.com/in/support
BANGLADESH	9612300300	
SRI LANKA	94117540540	www.samsung.com/support

