



AH68-01567N(Rev 0.0)

SAMSUNG

YP-T5

DIGITAL AUDIO PLAYER

yepp![™]

- MP3 and WMA playback
- Removable Storage Device
- Encoding function
- FM reception
- 3D sound
- Upgradable
- 12 hours of continuous play

Contents

Preparations

Safety Instructions	4
Features	6
Accessories	9
Location of Controls (yepp)	10

Connection to Computer

Connecting the yepp to a PC	12
Manual Installation of the USB Driver	16
Using the removable storage	20
● Downloading/Uploading files	20
● Disconnecting the USB cable	21
● Formatting	22
Installing yepp Studio	23
● To View Help on yepp Studio	25

Basic Usage

Playing Music and Turning Off the Device	26
Adjusting the Volume/Hold Function	27
Recording Voice	28
MP3 Encoding	29
Searching for Music/Voice Files	30
Listening to FM Radio	31
FM Encoding	33

Additional Usage

Loop Repeating	34
Using Navigation	35
Setting Playlist	36
Setting up MENU	37
Managing Files	38
● Deleting	38
● Formatting	39
Setting the Advanced Functions	40
Selecting the Playmode	41
Setting the EQ mode	42
Display	43
● Scroll Speed / Time	43
● Backlight	44
● Contrast	45
Power Off Time	46
● Time / Sleep	46
Encoding	47
● Bitrate / AutoSync Time	47
WOW Level	48
● Adjusting SRS and TruBass LEVEL	48
● WOW Optimum	48
Default Volume	49

Appendix







MENU Table	50
------------------	----

Customer Support

Troubleshooting	52
Specifications	54

Safety Instructions

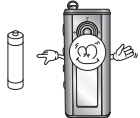
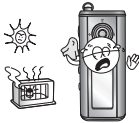
Read and understand all the instructions to avoid injury to yourself and damage to the equipment.

<p>Do not expose to extreme temperatures (above 95°F or below 23°F). Do not expose to moisture.</p> 	<p>Do not apply excessive pressure to the device.</p> 	<p>Do not let any foreign matter spill into the device.</p> 
<p>Do not place heavy objects on top of the device.</p> 	<p>Do not expose to chemicals such as benzene and thinners.</p> 	<p>Remove batteries when the device is left unused for a long period of time.</p> 
<p>Do not expose to direct sunlight or heat sources.</p> 	<p>Do not store in dusty areas.</p> 	<p>Do not try to disassemble and repair the device yourself.</p> 

* Please be aware that we disclaim all responsibility for damages from loss of saved or recorded data due to breakdown, repair or other causes.

Earphones

Follow Traffic Safety Instructions

- Do not use the earphones while driving an automobile or riding a bicycle. It's not only dangerous, but also against the law.
- An accident may result if you turn up the volume of the earphones too high while walking down the street, especially when crossing at intersections.

Protect your ears

- Do not turn the volume up too high. Doctors warn against prolonged exposure to high volumes.
- Stop using the device or turn the volume down if you get ringing in your ears.

Ambient operating conditions

- Ambient temperature : 5°C ~ 35°C (41°F ~ 95°F)
- Humidity : 10% ~ 75%

Environmental Information

- Follow local guidelines for waste disposal when discarding packaging, batteries, and old electronic appliances.
- yepp packaging uses cardboard, polyethylene etc., and does not use any unnecessary materials.

MP3 & WMA Playback

- MP3 is an MPEG1 Layer3 audio format.
- WMA is a Microsoft Windows Media audio format.

Removable Storage Device

- You can easily copy and paste files to the yepp player using Windows Explorer.

Encoding Function

- You can make an MP3 file from an external source using the ENC jack on the main unit.
- You can also convert an FM radio program into an MP3 file in real time.

FM Reception

- Listening to an FM program is made easy with Auto Search and Frequency Memory functions.

3D Surround Sound

- You will hear deep bass and 3D surround sound.

Upgradable

- You can upgrade the built-in programs when available. Add functions, CODEC, etc. Please check the yepp home page for upgrades.

DIGITAL SOUND yepp'

12-Hour Continuous Play

- This unit uses one AAA/LR03 alkaline battery. Operation can last up to 12hours. Actual playing time may vary according to the type and capacity of the battery.

Voice Recording Function

- You can do a Voice Recording with high quality and use it for a conference.

Sound

- You can adjust the equalizer manually.

Accessories



Player



Carrying case



Earphones



USB cable

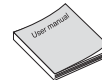

User manual



One Battery
(1.5V AAA/LR03 type)



Neck Strap



Direct Connect
USB Adaptor



Line In Cable



Installation CD

Model	YP-T5 H	YP-T5 V	YP-T5 X
Built-in memory	128MB	256MB	512MB

- The capacity of the useable built-in memory is less than indicated as the internal firmware uses a part of the memory as well.
- Design of accessories is subject to change, for the purposes of improvement, without notice.

Location of Controls (yep)

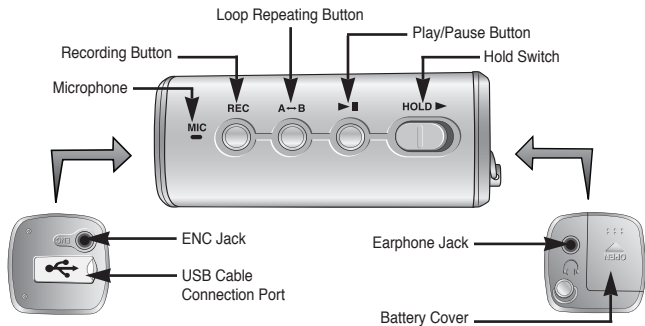

Display

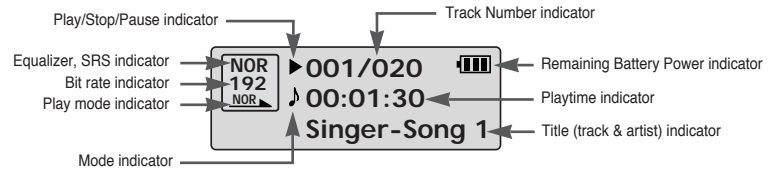

Inserting a Battery

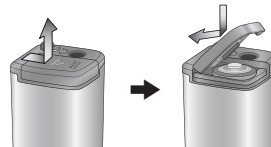

1 Slide the cover in the direction of the arrow to open.

2 Insert a battery to the right poles +, - and push-close the cover in the direction the arrow as indicated.

Note

- Do not place heavy objects on the cover.

Connecting the yepp to a PC

System Requirements.

The PC system must meet the following specifications:

- Pentium 133MHz or greater.
- Windows 98SE/ME/2000/XP.
- 40MB of available hard disk space
- CD-ROM drive.
(double speed or greater)
- USB port (1.1) supported.
- DirectX 8.0 or above.

Note

- Install the operating system in Administrator Account mode for Windows 2000 or XP. Otherwise, installation will not be completed.
- Windows ME, 2000 and XP can recognize the driver without installing the provided program. However, you must install the program in order to format yepp and upgrade firmware.
- If the YP-T5 program has not been installed in Windows 98, then it will not communicate with your removable disk. You must install the USB driver file first.

Before connecting yepp to PC, make sure to install USB driver. If "Add New Hardware Wizard" appears, press the [Cancel] button and install the USB driver.

Installing software

- 1 Insert the Installation CD into the CD-ROM drive. The picture shown below appears. Select [yepp USB Driver]



- 2 Click [Next] in the series of windows that appear.

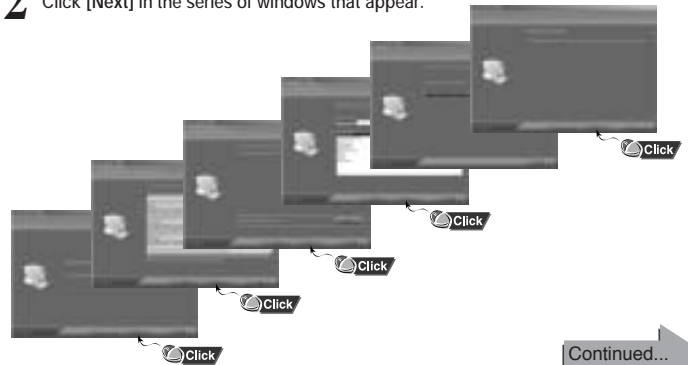

Continued...

Connecting the yepp to a PC

Connecting the yepp to a PC with a USB cable

- 3 Connect a USB cable to the USB port on the computer.
- 4 Connect the other end of a USB cable to the USB cable connection port on the bottom of the yepp, and press the ► button on the main unit.
 - If you disconnect the USB cable from your PC while implementing a command or initializing during USB driver installation, your PC may not function correctly.
- 5 The USB driver is installed with a message saying that it is searching for a new device. You may not see the display screen during installation. Go to the device manager to check that installation has been successfully completed.
- 6 Upon installation of the USB driver "SAMSUNG YP-T5" will appear in the [System Properties] → [Device Manager].

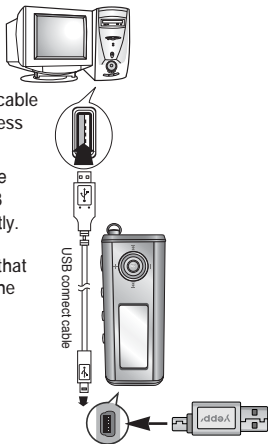

How to check the USB driver

- Windows 98:
Control Panel → System → Device Manager → Universal Serial Bus controllers/Samsung YP-T5 Class
 - Windows 2000/ME:
Control Panel → System → Hardware → Device Manager → Universal Serial Bus controllers → USB Mass Storage Device
 - Windows XP:
Control Panel → System → Hardware → Device Manager → Universal Serial Bus controllers → USB Mass Storage Device
- 7 When the USB driver is not installed automatically, refer to the next page.



Manual Installation of the USB Driver

Go to "Downloading/Uploading files" on page 20 if the USB driver is in place.
Follow these steps if the USB driver is not in place :

When an error occurs during installation of the USB driver

- 1 Check the device manager.
 - Windows 98/ME:
Control Panel → System → Device Manager
 - Windows 2000 (Professional):
Control Panel → System → Hardware →
Device Manager
 - Windows XP (Professional):
Control Panel → System → Hardware →
Device Manager



- 2 Check if there is a device listed with an exclamation point or a question mark (displayed as unknown device or USB device).

- 3 Double click on the device listed with an exclamation point or a question mark.

Note

- If you are using Windows 2000 and your version of Windows does not recognize the USB driver please download and install the latest service pack from windowsupdate.microsoft.com
- The installation method may vary depending on the type of PC or operating system. Contact your PC dealer or service center for installation information.
- If errors occur continuously when you install the USB driver, reconnect the USB cable after rebooting your system.

- 4 After selecting the driver, click on [Update Driver].



- 5 Select a compatible driver, click on [Next] to finish.



Manual Installation of the USB Driver

In Windows 98

Click [Next] button in the series of windows that appear.



USB driver location
[CD ROM]\setup\Drivers

- You must reboot your computer to complete the installation.



Note

- You cannot use it as a removable disk in Windows 98 if the YP-T5 program is not installed. Make sure to install the USB driver file first.

Using the removable storage

Downloading/Uploading files

- 1 Connect the yepp to your PC and turn it on.
- 2 Open Windows Explorer on PC.
- 3 Select the file to save and drag-and-drop it into the removable disk icon.
(In numerical, alphabetical order)





Notice

- The "WRITING/READING" message will appear during file download or upload. Disconnecting the USB cable while "WRITING/READING" is displayed may cause malfunction of the unit.
- The order of music files is not relative to the replay order when you select a Removable Disk in Windows Explorer.

Disconnecting the USB cable

After completing the file transmission, you must disconnect the cable in the following way:

- 1 Double-click on the green arrow in the taskbar on the bottom right of the window.

- 2 When the [Stop a Hardware device] message appears, press the [OK] button and disconnect the USB cable.



Note

- The green arrow is not displayed on the Task Bar in Windows 98 system. If "READY" message is shown in Display window, please disconnect the USB cable.

Using the removable storage

Formatting

- 1** Select the removable disk icon and click the right mouse button to select [Format].

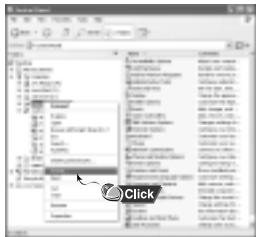

- 2** Press the [Start] button.
- All saved files will be formatted.
 - You can change the name of removable disk by selecting [Volume label].



Note

- By formatting, all previously preset menus will be initialized.
- Care must be taken as formatted files can not be recovered.

Installing yepp Studio

- 1** Insert the Installation CD into CD-ROM drive. Select [yepp Studio].



- 2** Select language



Continued... 

Installing yepp Studio

3 Click [Next] in the series of windows that appear.

- Please refer to Help for more information on how to use yepp Studio.



Note

- When the [Register Serial Number] message appears, at your first execution of yepp Studio, enter the yepp's serial number.

To View Help on yepp Studio

Run yepp Studio and press F1.

- Help will appear.

Move the arrow to the top of yepp Studio and right click on the mouse. The following selection window will appear.

- Click on Help and the Help window will appear.

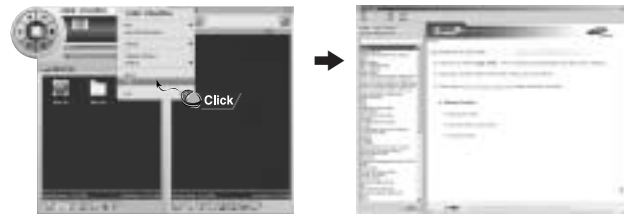

Note

- Music recognition technology and related data are provided by Gracenote and Gracenote CDDB® Music Recognition ServiceSM.
- CDDB is a registered trademark of Gracenote. The Gracenote logo and logotype, the Gracenote CDDB logo and logotype, and the "Powered by Gracenote CDDB" logo are trademarks of Gracenote. Music Recognition Service and MRS are service marks of Gracenote.

Playing Music and Turning Off the Device

Turning Power On and Off

- Power On : Press the ►|| button to turn on the power.
- Power Off : Press and hold the ►|| button to turn off the power.

Playing Music

Press the ►|| button.

- Playback starts.

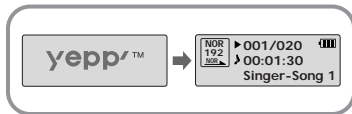

Pausing Music

Press the ►|| button to pause playback.

- If no buttons are pressed within 10 seconds (changes depending on settings), the yepp automatically powers off.
- While in Pause mode, briefly press ►|| again to resume playback.

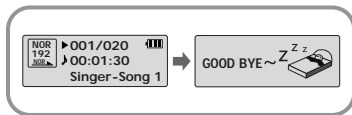

Note

- WMA files can be played only as music files with a compression rate of 48Kbps-192Kbps, that can be created in Windows Media Player (Version 8.0).
- The power off time can be set in the menu.

Adjusting the Volume/Hold Function

Adjusting the Volume

Press the player's **-**, **+** key during playback to adjust the volume.

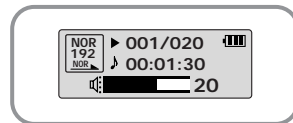

Note

- Volume ranges from 00 to 30.
- Press once to adjust the volume by one step.
Press and hold to increase or decrease the volume in greater increments.

HOLD Function

In Hold mode, all buttons are disabled.

Slide the  switch on the player in the direction of the arrow.

- When the button is pressed, the “ HOLD!” message will appear on the display.



Recording Voice

To Record Voice

- 1 Press the REC button to start voice recoding.
- 2 If the REC button is pressed again, the recording stops and a voice file is created.

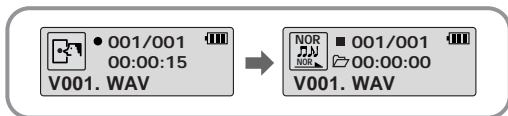

Note

- Recording is performed in order (V001, V002, etc.) and files are saved in the WAV format after recording.
- If the Memory is full, the Voice Recording is stopped automatically.
- Voice Recording does not work in FM Mode or when the Line In cable is connected.

MP3 Encoding

- 1 Connect the Audio Output port on the external audio source (or the Line Out port) to the ENC port on the device with the Line cable.

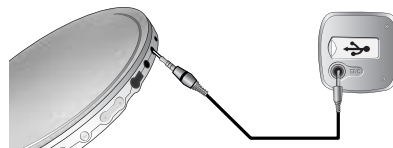

- 2 Press the REC button to start MP3 encoding.
 - If the ►|| button is pressed, encoding is paused and if the ►|| button is pressed again, the encoding resumes.
- 3 If the REC button is pressed during encoding, the encoding stops and an encoding file is created.

Note

- Bit Rates can be set within the range of 32Kbps~128Kbps.
- Volume can be adjusted from level 0 to 10 while monitoring the Encoding.

Notice



- Do not disconnect the Line cable during Encoding.
- If the battery is not charged enough, encoding will not be done.
- Adjust the volume of the external audio source to a suitable level and encode it. If the volume level is extremely high, the sound quality may not be good.

Searching for Music/Voice Files

To search for specific parts during play

- Pull and hold the  keys to the left or right during playback to search for the part you want to listen to.
- Release the key to resume play normally.

To change tracks during play

- Pull the  key briefly during playback to play the next track.
- Pull the  key briefly within 5 seconds after playback starts to move to and play the previous track. Pull the  key briefly after five seconds to play the current track from the beginning.

To change tracks when stopped

- Pull the  keys to the left or right in stop mode to move to the previous/next track.

Note

- VBR(Variable Bit Rate) file: A file that constantly changes the compression rate according to the type of sounds, such as their pitch, in the file.
- In the case of a VBR file, you cannot move to and play the previous track even if you push the  key within 5 seconds after playback starts.
- Files that were downloaded in MP2 or MP1 and had their file extension changed to MP3 may not play.

Listening to FM Radio



First, press the  key to display the menu screen and select FM Radio.

Manual Search for a Frequency

- Pull the  keys briefly to search manually for the frequency you want.



Manual Storage of a Frequency

- After searching manually for the frequency you want, press and hold the  key to display the Save screen.
- Use the  keys to select the number you want to assign to save the frequency and then press the  key.

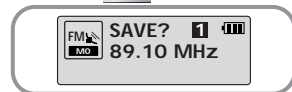

Note

- To exit from FM Mode press the  key.
- Mono (MO) or Stereo (ST) is automatically selected.

Automatic Search for a Frequency

- Pull and hold the  keys to search for and stop at frequencies with reception.



Automatic Storage of a Frequency

- Press and hold the A<->B button while in FM Mode.
- Frequencies within the range of 87.50MHz to 108.00MHz are automatically selected and stored.
- Frequencies are automatically stored, starting from 1.



Number of channels saved.

Listening to FM Radio

Searching Stored Frequencies

- 1 Press the **▶||** button in FM Mode.
 - PRESET screen will appear.
- 2 Use the **◀◀▶▶** keys to move to the frequency you want.

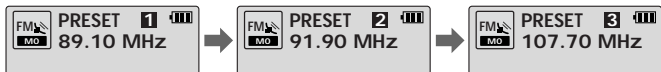

Deleting Stored Frequencies

- After moving to the PRESET number you want to delete, press and hold the  key.
- The saved PRESET number will be deleted.

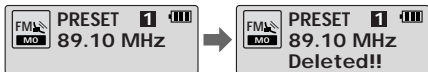

Note

- You can store up to 20 frequencies.
- Press the **▶||** button in the PRESET screen to exit the PRESET mode.

FM Encoding

- 1 Press the REC button during FM reception.
 - Encoding of the currently transmitted FM broadcast begins.

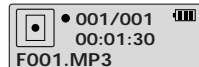

- 2 Press the REC button again.
 - A file is created and the encoding stops.
 - Files are saved in order of F001, F002, F003...and stop automatically when the memory is full.

Loop Repeating

Starting Point

While playing music files, press the A↔B button briefly at the beginning of the loop you want to set.

A↔ appears in the display.

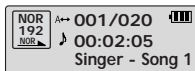

Ending Point

Press the A↔B button briefly again to set the end of the loop.

A↔B appears in the display.
The loop is played repeatedly.

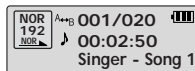

Note

- Press the A↔B button briefly to cancel the loop.
- Loop Repeat is automatically released if you Speed Search with the ⏮, ⏭ buttons.

Using Navigation

You can easily search for files or switch modes using the Navigation function.

- 1 Press and hold the  button to move to Navigation mode.

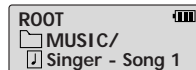

When the folder is in play or stop status.

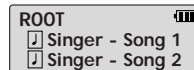

When the file is in play or stop status.

- 2 Select the file or folder that you want to play.
 - ⏪ : When moving to a higher-level folder.
 - ⏩ : When moving to a lower-level folder.
 - - , + : When moving to a file or folder in the same directory.
 -  : Move to the next folder down. When there is not a lower folder, the selected file will be designated as part of the playlist.



- 3 Press the ⏭ button.
 - The selected file will be played.
 - If you select a folder, all the files in the selected folder will be played.

Note

- Press and hold the  key in Navigation mode to exit Navigation mode.

Setting Playlist

Setting Playlist

- Move to the file you want in Navigation mode and press the  key.
- The selected file will be marked.
- To release the playlist setting, move to the marked file in Navigation mode and press the  key again.

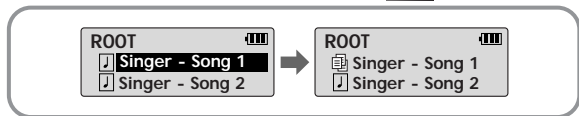

Playing Playlist



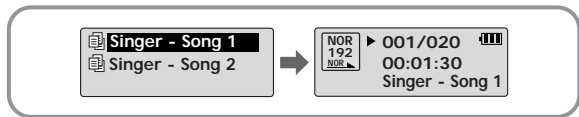

- 1 Press and hold the A↔B button in Music mode.
 - The Playlist you set will be displayed.
- 2 Move to the file you want to play and press the  button.
 - The selected file will be played.



Note

- Select PLAYLIST in File Delete (see "Deleting") to release all the playlists you set.

Setting up MENU

- Press the  key to switch to MENU mode.
- Use the  key to move and press the  key briefly to select the menu you want.
- Press and hold the  key to exit the MENU mode.

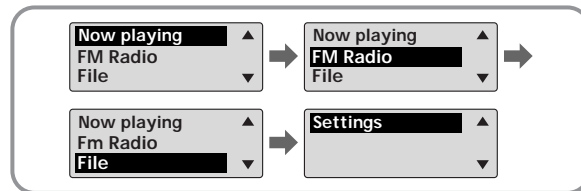

- Now playing : To check the track currently played.
- FM Radio : To listen to FM radio.
- File : To delete or format files.
- Settings : To set the detailed function of yepp.

Note

- In MENU mode, no input for 15 seconds will cancel the MENU mode.

Managing Files

Deleting

- 1 Select File in the MENU. (refer to "Setting up MENU")
- 2 In File, select File Delete and the mode the target file is in.
- 3 Use the **-**, **+** key to move to the file you want to delete, press the  key and select CONFIRM.
Press the **⏪** key briefly to exit the setting.

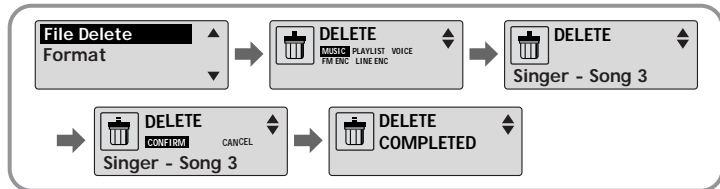

Formatting

- 1 Select File in the MENU. (refer to "Setting up MENU")
- 2 Select Format in File.
 - Formatting is performed if CONFIRM is selected.

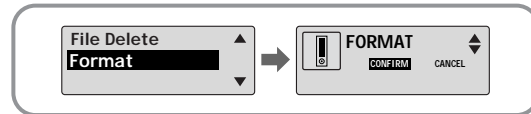

Note

- All files will be deleted when formatting the built-in memory.
- It is recommended that formatting be carried out on a PC that has the provided program installed as formatting in the Menu may take a long time.

Setting the Advanced Functions

Settings

- 1 Select **Settings** in the MENU. (Refer to "MENU Mode")
- 2 In Settings, use the **-**, **+** key to move to the function you want and press the  key to select.
 - Use **⏪** key to move to upper menu.

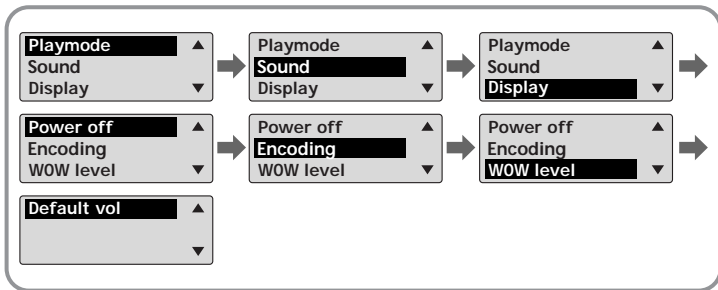

Selecting the Playmode

- 1 Select **Playmode** in Settings.
- 2 In Play mode, use the **-**, **+** key to move to the mode you want and press the  key to select.

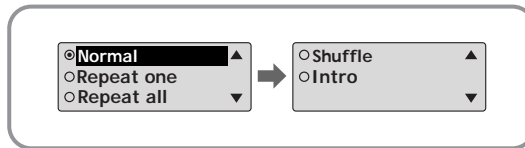

- Normal: To play all the tracks in order one time.
- Repeat one: To repeat one track.
- Repeat all: To repeat all tracks.
- Shuffle: To play tracks at random.
- Intro: To listen to the first part of all saved tracks for 10 seconds.

Setting the EQ mode

- 1 Select **Sound** in Settings.
- 2 In **Sound**, use the **-**, **+** key to move to the sound mode you want and press the  key.
 - **SRS** (⊙): You will hear 3D Stereo sound.
 - **TruBass** (≡): This is a bass boost feature that adds fullness to the sound.
 - **WOW**: This feature allows you to enjoy the SRS and Trubass features simultaneously.
 - If you want bass boost, select **DBB**.

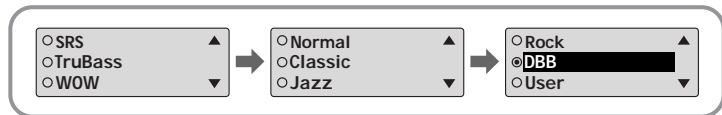

- 3 Select **User** and set the Bass/Treble if you want to set the tone yourself, apart from the specified tone.
 - Bass/Treble can be adjusted from 0 to 10 with the **-**, **+** key.

Note

- **SRS** (⊙) is a trademark of SRS Labs, Inc.
WOW technology is incorporated under license from SRS labs, Inc..
- Please adjust the volume to a suitable level, as the volume may increase in the SRS setting.
- This unit supports sampling frequencies of 32KHz, 44.1KHz or 48KHz.
- The SRS function is not set for voice recording files.

Display

Select **Display** in Settings.

Scroll Speed

- Use the **-**, **+** key to set the scroll speed.
- The setting range for the scroll speed, which adjusts the speed of the track title flow, is 0 to 10.

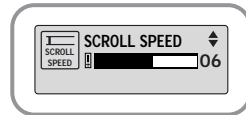

Time

- **Play time**: Displays the current play time
- **Remain time**: Displays the remaining play time
- **Used size**: Displays the size of memory used.
- **Free size**: Displays the remaining memory

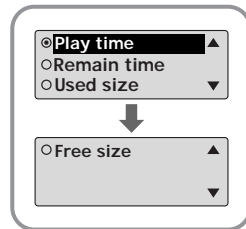

Display

Backlight

[Light Time - Jog]

- Use the **—**, **+** key to set the  Light-On time.
- The setting range for Light-On Time is 0 to 10 seconds.
- When set to On, the Light stays on continuously.

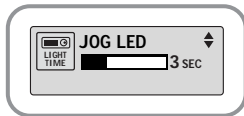

[Light Time - LCD]

- Use the **—**, **+** key to set the LCD Light-Off time.
- The setting range for Light-On Time is 0 to 10 seconds.
- When set to On, the Light stays on continuously.

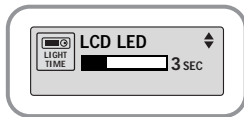

[LCD color]

- Use the **—**, **+** key to select the LCD color you want, out of 7 colors.

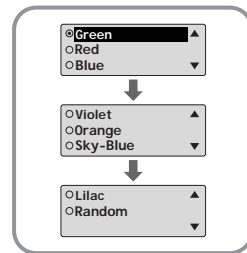

Note

- The light does not illuminate when the residual battery level is insufficient.

Contrast

- Use the **—**, **+** key to set the contrast.
- The setting range for the contrast, which adjusts the brightness of the screen, is from 0 to 10.

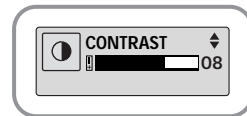

Power Off Time

Select Power off in Settings.

Time

- Use the **←**, **→** key to set the Power-Off time.
- You can set the time from 5s to 1 minute. If no key is pressed after play stops, the unit will automatically turn off after the time you set.
- If you set it to OFF, it will not turn off automatically.

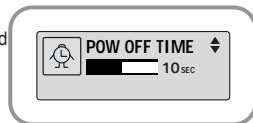

Sleep

- Use the **←**, **→** key to set the Sleep time.
- 30, 60, 90 and 120 minutes are available for sleep time, and it will automatically turn off after the time you set.
- When set to OFF, the power does not turn off automatically.

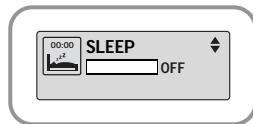

Encoding

Select Encoding in Settings.

Bitrate

- Use the **←**, **→** key to set the encoding bit rate you want.
- When encoding music into an MP3 file, you can select one of the following bit rates: 32Kbps, 48Kbps, 64Kbps, 96Kbps and 128Kbps.

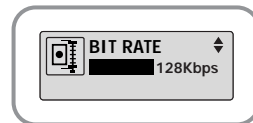

AutoSync Time

- Use the **←**, **→** key to set the AutoSync Time.
- AutoSync Time is a function for separating and saving MP3 files when there is no sound for a set time during MP3 encoding.
- The setting range for the AutoSync Time is from 2 to 5 seconds.
- If AutoSync Time is set to OFF, encoding keeps going even if there is no sound, and then it is saved as one file.

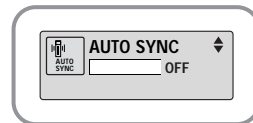

Note

- Auto Sync function can support from 64Kbps to 128Kbps.

WOW Level

Select WOW level in Settings.

Adjusting SRS and TruBass LEVEL

- If you select SRS or TruBass in WOW level, you can adjust the level of SRS and TruBass.
- Use the **-**, **+** key to select the level you want.
- The level for SRS and TruBass can each be set within the range of 0 to 10.

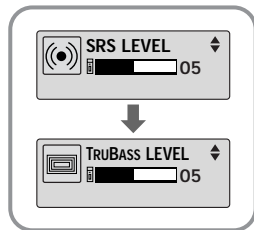

WOW Optimum

- If you select WOW Optimum, it optimizes the SRS function according to the device connected.
- Use the **-**, **+** key to select Speaker, Headphone, Earphone or Carpack(car cassette adapter).

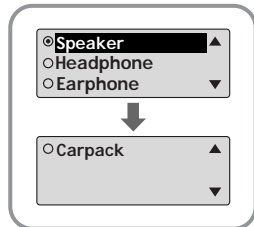

Default Volume

Select Default vol in Settings.

Default vol

- Use the **-**, **+** key to set the default volume value.
- It is possible to set the default volume to a value between 0 and 25(MAX).
If the power is turned on again after having adjusted the volume above the default value, music is played at the default volume.
- If the power is turned on again after the volume was set to within the default value, the music is replayed at the previously played volume.

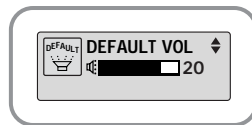

MENU Table

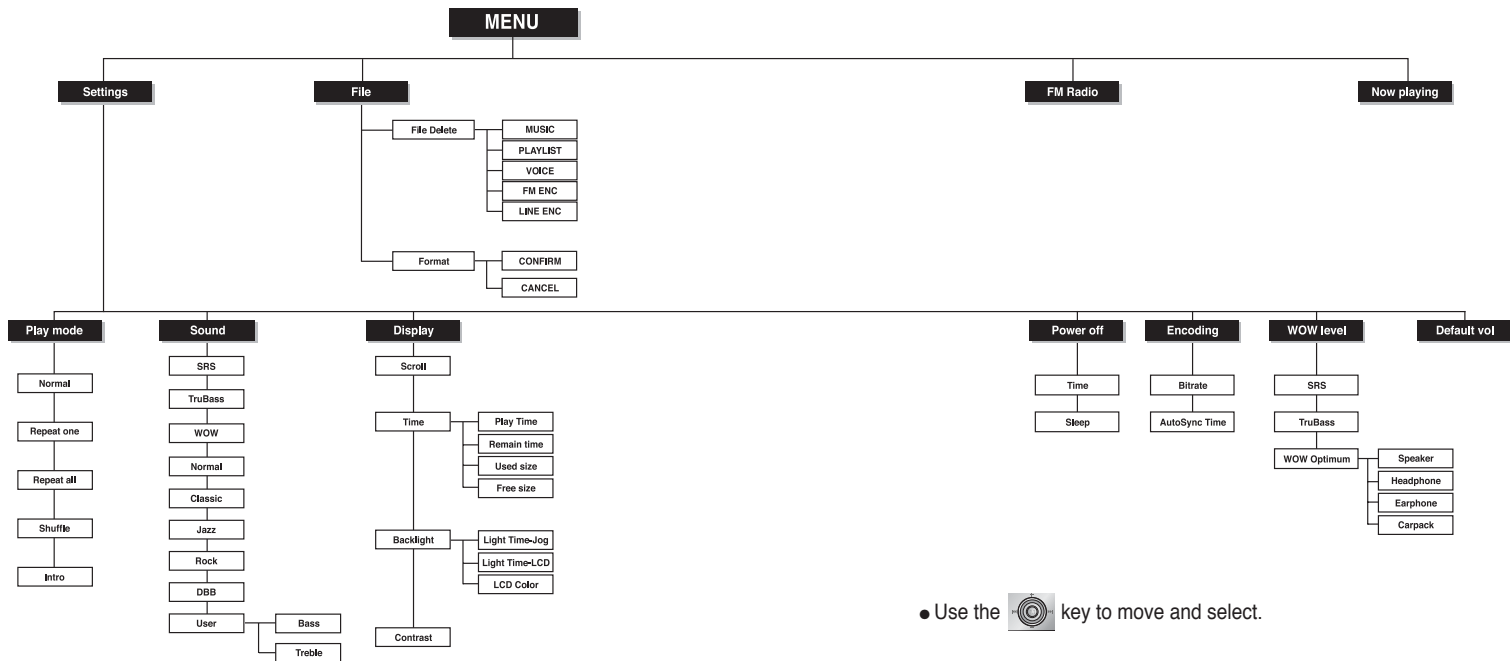

● Use the  key to move and select.

Troubleshooting

The software doesn't work

- Refer to the recommended PC specifications.
-

yepp does not work and the LCD displays nothing.

- Check the battery capacity
 - Check to see if the battery is inserted to the right poles (+ , -)
-

In PLAY mode, music is not played after pressing the ►|| button

- Check to see if MP3 or WMA files are saved in the built-in memory.
 - Check to see if the HOLD button is locked.
-

Files cannot be downloaded.

- Check to see if the driver is installed correctly in the computer.
 - Check the connection between yepp and computer.
 - Check and/or replace the battery, turn on the yepp's power.
 - Operating system limits the number of files you can save.
Please save your music files by creating a subfolder.
 - Check if the memory is full.
-

Backlight does not work.

- Check the backlight setup.
- When the battery power is low, the backlight will go out.

The buttons do not work.

- Check setting of Hold switch.
 - Remove the battery once and then insert it again.
-

The yepp keeps being turned off.

- In Stop mode, the power is automatically turned off after ten seconds (changes depending on settings).
 - Check to see if there are files saved in it.
-

Something's wrong with play time displayed during Play mode.

- "VBR SONG" message is displayed while VBR (Variable Bit Rate) file is playing.
-

LCD window is dark

- Check Contrast

Specifications

Model	YP-T5
Built-in Memory capacity	128MB(YP-T5 H), 256MB(YP-T5 V), 512MB(YP-T5 X)
Voltage	1.5V X 1 (AAA/LR03 size alkaline battery)
Playing time	lasts up to 12hours (Alkaline battery, MP3 128Kbps, Vol level 20)
Dimensions/Weight	23X54X23mm/24g (without battery)
Case	Plastic/Aluminuma
Noise Ratio	80dB with 20KHz LPF
Earphones Jack Output Power	5mW(Max 10mW)/CH (16Ω)
Output Frequency Range	20Hz~20KHz
Operating Temperature Range	-5 ~ +35°C(23~95°F)
FM Frequency	87.50 ~ 108.00 MHz
FM Signal to Noise Ratio	45dB
FM T.H.D	1%
FM Useable Sensitivity	10dB
File Support	MPEG1/2/2.5 Layer3(8Kbps ~ 320Kbps, 8KHz ~ 48KHz) WMA (48Kbps ~ 192Kbps, 8KHz ~ 48KHz)

MEMO