

SAMSUNG

Microwave Oven

Owner's Manual

MS83HCE



Safety	2
Safety Precautions	2
Installing Your Microwave oven	3
How a Microwave Oven Works	4
Your New Microwave oven	4
Checking Parts	4
Setting Up Your Microwave Oven	4
Control Panel Buttons	5
Operation	5
Setting the Clock.....	5
Using the Pause/Cancel Button	5
Using the One Minute + Button.....	5
Using the Sensor Cook Buttons	6
Sensor Cooking Guide.....	6
Using the Instant Cook Buttons	6
Defrosting Automatically	7
Auto Defrosting Settings	7
Setting Cooking Times & Power Levels.....	7
Demonstration Mode	8
Using the More/Less Buttons	8
Switching the Beeper On/Off	8
Using the Kitchen Timer	8
Setting the Child Protection Lock.....	8
Cooking Instructions	8
Cooking Utensils	8
Testing Utensils	9
Cooking Techniques	9
General Tips	9
Auto Sensor Cook.....	10
Utensils & Cover For Sensor Cooking	10
Important.....	10
Appendix	11
Troubleshooting Guide	11
Care and Cleaning.....	11
Error Message	11
Specifications.....	12

Safety

PRECAUTIONS TO AVOID POSSIBLE EXPOSURE TO EXCESSIVE MICROWAVE ENERGY

Failure to observe the following safety precautions may result in harmful exposure to microwave energy.

- (a) Under no circumstances should any attempt be made to operate the oven with the door open or to tamper with the safety interlocks (door latches) or to insert anything into the safety interlock holes.
- (b) Do not place any object between the oven door and front face or allow food or cleaner residues to accumulate on sealing surfaces. Ensure that the door and door sealing surfaces are kept clean by wiping after use first with a damp cloth and then with a soft dry cloth.
- (c) Do not operate the oven if it is damaged until it has been repaired by a qualified microwave service technician trained by the manufacturer. It is particularly important that the oven door closes properly and that there is no damage to the:
 - (1) Door, door seals and sealing surfaces
 - (2) Door hinges (broken or loose)
 - (3) Power cable
- (d) The oven should not be adjusted or repaired by anyone other than a properly qualified microwave service technician trained by the manufacturer.

Safety Precautions

IMPORTANT SAFETY INSTRUCTIONS.

READ CAREFULLY AND KEEP FOR FUTURE REFERENCE.

Before cooking food or liquids in your microwave oven, please check that the following safety precautions are taken.

1. **DO NOT** use any metallic cookware in the microwave oven:
 - Metallic containers
 - Dinnerware with gold or silver trimmings
 - Skewers, forks, etc.

Reason: Electric arcing or sparking may occur and may damage the oven.
2. **DO NOT** heat:
 - Airtight or vacuum-sealed bottles, jars, containers Ex) Baby food jars
 - Airtight food. Ex) Eggs, nuts in shells, tomatoes

Reason: The increase in pressure may cause them to explode.
Tip: Remove lids and pierce skins, bags, etc.
3. **DO NOT** operate the microwave oven when it is empty.

Reason: The oven walls may be damaged.
Tip: Leave a glass of water inside the oven at all times.
The water will absorb the microwaves if you accidentally set the oven going when it is empty.
4. **DO NOT** cover the rear ventilation slots with cloths or paper.

Reason: The cloths or paper may catch fire as hot air is evacuated from the oven.
5. **ALWAYS** use oven gloves when removing a dish from the oven.

Reason: Some dishes absorb microwaves and heat is always transferred from the food to the dish. The dishes are therefore hot.
6. **DO NOT** touch heating elements or interior oven walls.

Reason: These walls may be hot enough to burn even after cooking has finished, even though they do not appear to be so. Do not allow inflammable materials to come into contact with any interior area of the oven. Let the oven cool down first.
7. To reduce the risk of fire in the oven cavity:
 - Do not store flammable materials in the oven
 - Remove wire twist ties from paper or plastic bags
 - Do not use your microwave oven to dry newspapers
 - If smoke is observed, keep the oven door closed and switch off or disconnect the oven from the power supply
8. Take particular care when heating liquids and baby foods.
 - ALWAYS allow a standing time of at least 20 seconds after the oven has been switched off so that the temperature can equalize.
 - Stir during heating, if necessary, and ALWAYS stir after heating.
 - Take care when handling the container after heating. You may burn yourself if the container is too hot.
 - A risk of delayed eruptive boiling exists.
 - To prevent delayed boiling and possible scalding, you should put a plastic spoon or glass stick into the beverages and stir before, during and after heating.

Reason: During the heating of liquids the boiling point can be delayed; this means that eruptive boiling can start after the container is removed from the oven. You may scald yourself.
 - In the event of scalding, follow these FIRST AID instructions:

Safety Precautions (continued)

- * Immerse the scalded area in cold water for at least 10 minutes.
 - * Cover with a clean, dry dressing.
 - * Do not apply any creams, oils or lotions.
- **NEVER** fill the container to the top and choose a container that is wider at the top than at the bottom to prevent the liquid from boiling over. Bottles with narrow necks may also explode if overheated.
 - **ALWAYS** check the temperature of baby food or milk before giving it to the baby.
 - **NEVER** heat a baby's bottle with the teat on, as the bottle may explode if overheated.
9. Be careful not to damage the power cable.
- Do not immerse the power cable or plug in water and keep the power cable away from heated surfaces.
 - Do not operate this appliance if it has a damaged power cable or plug.
10. Stand at arm's length from the oven when opening the door.
Reason: The hot air or steam released may cause scalding.
11. Keep the inside of the oven clean.
Reason: Food particles or spattered oils stuck to oven walls or floor can cause paint damage and reduce the efficiency of the oven.
12. You may notice a "Clicking" sound during operation (especially when the oven is defrosting).
Reason: This sound is normal when the electrical power output is changing.
13. When the microwave oven is operating without any load, the power will be cut off automatically for safety. You can operate normally after letting it stand for over 30 minutes.

IMPORTANT SAFETY INSTRUCTIONS

During cooking, you should look into the oven from time to time when food is being heated or cooked in disposable containers of plastic, paper or other combustible materials.

IMPORTANT

Young children or infirm persons should **NEVER** be allowed to use or play with the microwave oven. Nor should they be left unattended near the microwave oven when it is in use. Items of interest to children should not be stored or hidden just above the oven.

WARNING:

If the door or door seals are damaged, the oven must not be operated until it has been repaired by a competent person.

WARNING:

It is hazardous for anyone other than a competent person to carry out any service or repair operation which involves the removal of a cover which gives protection against exposure to microwave energy.

WARNING:

Liquids and other foods must not be heated in sealed containers since they are liable to explode.

WARNING:

Only allow children to use the oven without supervision when adequate instructions have been given so that the child is able to use the oven in a safe way and understands the hazards of improper use.



Please recycle or dispose of the packaging material for this product in an environmentally responsible manner.

Installing Your Microwave oven

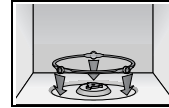
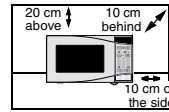
Place the oven on a flat, level surface that strong enough to safely bear the weight of the oven.



1. When you install your oven, Make sure there is adequate ventilation for your oven by leaving at least 10 cm (4 inches) of space behind, on the sides of the oven and 20 cm (8 inches) of above.
2. Remove all packing materials inside the oven. Install the roller ring and turntable. Check that the turntable rotates freely.
3. This microwave oven has to be positioned so that plug is accessible.

-  **Never** block the air vents as the oven may overheat and automatically switch itself off. It will remain inoperable until it has cooled sufficiently.
-  For your personal safety, plug the cable into a 3-pin, 230 Volt, 50Hz, AC earthed socket. If the power cable of this appliance is damaged, it must be replaced by a special cable. Contact your local dealer to have it replaced.
-  **Do not** install the microwave oven in hot or damp surroundings like next to a traditional oven or radiator. The power supply specifications of the oven must be respected and any extension cable used must be of the same standard as the power cable supplied with the oven. Wipe the interior and the door seal with a damp cloth before using your microwave oven for the first time.

How a Microwave Oven Works

Cooking Principle

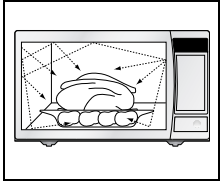

1. The microwaves generated by the magnetron are distributed uniformly as the food rotates on the turntable. The food is thus cooked evenly.
2. The microwaves are absorbed by the food up to a depth of about 1 inch (2.5 cm). Cooking then continues as the heat is dissipated within the food.
3. Cooking times vary according to the recipient used and the properties of the food:
 - Quantity and density
 - Water content
 - Initial temperature (refrigerated or not)

As the centre of the food is cooked by heat dissipation, cooking continues even when you have taken the food out of the oven. Standing times specified in recipes and in this booklet must therefore be respected to ensure:

- Even cooking of the food right to the centre
- The same temperature throughout the food

Your New Microwave oven

Checking Parts

Unpack your microwave oven and check to make sure that you have all the parts shown here. If any part is missing or broken, call your dealer.

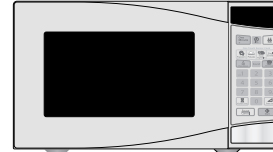

Microwave oven



Glass tray



Roller guide ring

Setting Up Your Microwave Oven

1. Place the oven on a flat, sturdy surface and plug the cord into a grounded outlet. Once plugged in, the display on your oven will show:



2. Open the oven door by pressing the button below the control panel.
3. Wipe the inside of the oven with a damp cloth.
4. Place the pre-assembled ring in the indentation in the center of the oven.

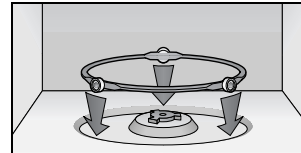

5. Place the glass tray on top of the ring so that the three glass tabs in the center of the tray fit securely into the tabs on the floor of the oven.

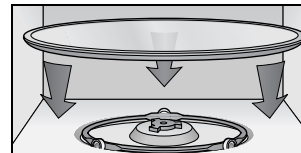

Your New Microwave oven

Control Panel Buttons

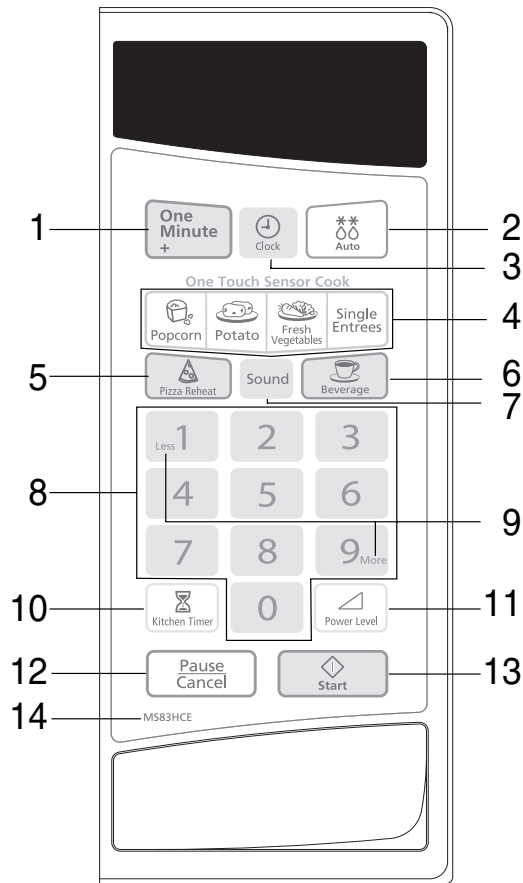

- | | |
|----------------------------------|-------------------|
| 1. One Minute + | 7. Sound |
| 2. Auto Defrost | 8. Number Buttons |
| 3. Clock | 9. More/Less |
| 4. One Touch Sensor Cook Buttons | 10. Kitchen Timer |
| 5. Pizza Reheat (INSTANT COOK) | 11. Power Level |
| 6. Beverage (INSTANT COOK) | 12. Pause/Cancel |
| | 13. Start |
| | 14. Model Number |

Operation

Setting the Clock

1. Press the **Clock** button. The “ENTER” and “TIME” indicators flash.
2. Use the number buttons to enter the current time. You must press at least three numbers to set the clock. If the current time is 5:00 enter, 5,0,0.
3. When 5 seconds has elapsed, “ENTER” indicator flash and “Cloc” will be displayed.
4. Press **Clock** again. A colon will blink, indicating that the time is set.
If there is a power interruption, you will need to reset the clock.
*You can check the current time while cooking is in progress by pressing the **Clock** button.*

Using the Pause/Cancel Button

The **Pause/Cancel** button allows you to clear instructions you have entered. It also allows you to pause the oven’s cooking cycle, so that you can check the food.

- To pause the oven during cooking: press **Pause/Cancel** once. To restart, press **Start**.
- To stop cooking, erase instructions, and return the oven display to the time of day: press **Pause/Cancel** twice.
- To correct a mistake you have just entered: press **Pause/Cancel** once, then re-enter the instructions.

Using the One Minute + Button

This button offers a convenient way to heat food in one minute increments at the High power level.

1. Press the **One Minute+** button once for each minute you wish to cook the food. For example, press it twice for two minutes. The time will display, and the oven starts automatically.

*Add minutes to a program in progress by pressing the **One Minute+** button for each minute you want to add.*

Operation

Using the Sensor Cook Buttons

By actually sensing the steam that escapes as food heat, this feature automatically adjusts the oven's heating time for various types and amounts of precooked food. All food should be precooked and at refrigerator temperature.

1. Press the **Sensor Cook** button corresponding to the food you are cooking (**Popcorn**, for example). The display shows "■■■■" and your microwave oven will begin cooking automatically.
When cooking popcorn, wait at least five minutes between each bag to avoid overheating the glass tray. If you want to check the current time while cooking is in progress, press the **Clock** button.

Sensor Cooking Guide

- Follow the instructions below when sensor cooking different types of food.

Food	Amount	Procedure
Potatoes	1 to 4 EA.	Prick each potato several times with fork. Place on turntable in spoke-like fashion. Let stand 3-5 min. Let oven cool for at least 5 minutes before using again.
Fresh Vegetables	1 to 4 cups	Place fresh vegetables in microwave-safe dish and add 2 Tbsp of water. Cover with microwave safe plastic wrap or lid. If using plastic wrap be sure to leave a small opening near the edge of dish for ventilation. Remove vegetable from oven let sit covered for 2 minutes, stir or serve. Let oven cool for at least 5 minutes before using again.
Single Entrees	200 to 400 g	Remove food from outer wrapping and follow box instructions for covering and standing. Let oven cool for at least 5 minutes before using again.
Popcorn	85 to 100 g (1 package)	Use only one microwave-only bag of popcorn at a time. Use caution when removing and opening hot bag from oven. Let oven cool for at least 5 minutes before using again.

Using the Instant Cook Buttons

1. Press the **Instant Cook** button corresponding to the food you are cooking (**Beverage**, for example). The display shows the first serving size. ("ENTER" and "QTY." will flash):
2. Press the button repeatedly to select the serving size you want. The display will cycle through all available serving sizes. Once you select the correct serving size, the microwave will begin cooking automatically.

When the cooking time is over, the oven will beep. The oven will then beep every minute.

Item	Weight	Remarks
Beverage	½ cup 1 cup 2 cups	<ul style="list-style-type: none">• Use measuring cup or mug ; do not cover.• Place the beverage in the oven.• After heating, stir well.
Pizza reheat	1 Slice 2 Slices 3 Slices	<ul style="list-style-type: none">• Put the pizza on a microwave-safe plate with wide end of slice towards the outside edge of the plate.• Do not let slices overlap. Do not cover.• Before serving, let stand 1-2 min.

Operation

Defrosting Automatically

To thaw frozen food, set the weight of the food and the microwave automatically sets the defrosting time, power level and standing time.

1. Press the **Auto Defrost** button. The display shows “.0 kg”. (“ENTER” and “kg” will flash).
2. To set the weight of your food, press the **Number** buttons. Weight selection is possible from 0.1kg to 1.5 kg.
3. Press the **Start** button to begin defrosting. The oven calculates the defrosting time and starts automatically. Twice during defrosting, the oven will beep to let you know when to turn the food over.
4. Open the oven door, and turn the food over.
5. Press the **Start** button to resume defrosting.

Auto Defrosting Settings

The following table presents the defrosting programme, quantities, standing times and appropriate recommendations.

Remove all kinds of packaging material before defrosting. Place meat, poultry and fish on a flat microwavable plate.

Food	Portion	Standing Time	Recommendation
Meat, Poultry or Fish	100-1500g	15-60min.	Shield the edges with aluminium foil. Turn the pieces over, when the oven beeps. This programme is suitable for meat such as steaks, chops or minced meat, chicken pieces, whole chicken or fish fillets.

Setting Cooking Times & Power Levels

Your microwave allows you to set up to two different stages of cooking, each with its own time length and power level. The power level button lets you control the heating intensity from Warm (1) to High (0).

One-stage Cooking

For simple one-stage cooking, you only need to set a cooking time. The power level is automatically set to High. If you want to set the power to any other level, you must set it using the **Power Level** button.

1. Use the number buttons to set a cooking time. You can set a time from one second to 99 minutes, 99 seconds. To set a time over one minute, enter the seconds too. **For example, to set 20 minutes, enter 2, 0, 0, 0.**
2. To set the power level to something other than High, press the **Power Level** button, then use the number buttons to enter a power level.

Power Levels:

1 = PL:10 (Warm)	6 = PL:60 (Simmer)
2 = PL:20 (Low)	7 = PL:70 (Medium High)
3 = PL:30 (Defrost)	8 = PL:80 (Reheat)
4 = PL:40 (Medium Low)	9 = PL:90 (Sauté)
5 = PL:50 (Medium)	0 = PL:Hi (High)

3. Press the **Start** button to begin cooking. To change the power level, press **Pause/Cancel** before you press **Start**, and re-enter all of the instructions. Some recipes require different stages of cooking at different temperatures. You can set multiple stages of cooking with your microwave.

Multi-stage Cooking

1. Follow steps 1 and 2 in the “One-Stage Cooking” section on the previous page. *When entering more than one cooking stage, the **Power Level** button must be pressed before the second cooking stage can be entered. To set the power level at High for a stage of cooking, press the **Power Level** button twice.*
2. Use the number buttons to set a second cooking time.
3. Press the **Power Level** button, then use the number buttons to set the power level of the second stage of cooking.
4. Press **Start** to begin cooking. You can check the Power Level while cooking is in progress by pressing the **Power Level** button.

Operation

Demonstration Mode

You can use the Demonstration Mode to see how your microwave oven operates without the oven heating.

1. Hold the **0** button and then press the **1** button.
To turn demo mode off, repeat step 1 above.

Using the More/Less Buttons

The **More/Less** buttons allow you to adjust pre-set cooking times. They only work in the **Instant, Kitchen Timer or Time Cook modes**. Use the **More/Less** button only after you have already begun cooking with one of these procedures. The **More/Less** feature cannot be used with the **Sensor Cook** button.

1. To **ADD** more time to an automatic cooking procedure: Press the **More(9)** button.
2. To **REDUCE** the time of an automatic cooking procedure: Press the **Less(1)** button.

*If you wish to increase/decrease in **Time Cook mode** by 10sec, press the **More(9)** or **Less(1)** button.*

Switching the Beeper On/Off

You can switch the beeper off whenever you want to.

1. Press the **Sound** button. The display shows "On".
("START" will flash)
2. Press the **Sound** button to turn the volume off. The display shows: "OFF". ("START" will flash)
3. Press **Start**.
The display returns to the time of day.

Using the Kitchen Timer

1. Press the **Kitchen Timer** button.
2. Use the **Number** buttons to set the length of time you want the timer to run.
3. Press **Start** to begin Kitchen Timer.
4. The display counts down and beeps when the time has elapsed.

Note: The microwave does not turn on when the Kitchen timer is used.

Setting the Child Protection Lock

You can lock your microwave oven so it can't be used by unsupervised children.

1. Hold the "0" button and then press the **2** button. The display shows "Loc".

At this point, the microwave oven cannot be used until it is unlocked. To unlock it, repeat step 1 above.

Cooking Instructions

Cooking Utensils

Recommended Use

- **Glass and glass-ceramic bowls and dishes** — Use for heating or cooking.
- **Microwavable browning dish** — Use to brown the exterior of small items such as steaks, chops, or pancakes. Follow the directions provided with your browning dish.
- **Microwavable plastic wrap** — Use to retain steam. Leave a small opening for some steam to escape and avoid placing it directly on the food.
- **Wax paper** — Use as a cover to prevent spattering.
- **Paper towels and napkins** — Use for short-term heating and covering; they absorb excess moisture and prevent spattering. Do not use recycled paper towels, which may contain metal and can catch fire.
- **Paper plates and cups** — Use for short-term heating at low temperatures. Do not use recycled paper, which may contain metal and can catch fire.
- **Thermometers** — Use only those labeled "Microwave Safe" and follow all directions. Check the food in several places. Conventional thermometers may be used once the food has been removed from the oven.

Limited Use

- **Aluminum foil** — Use narrow strips of foil to prevent overcooking of exposed areas. Using too much foil can damage your oven, so be careful.
- **Ceramic, porcelain, and stoneware** — Use these if they are labeled "Microwave Safe". If they are not labeled, test them to make sure they can be used safely. Never use dishes with metallic trim.
- **Plastic** — Use only if labeled "Microwave Safe". Other plastics can melt.
- **Straw, wicker, and wood** — Use only for short-term heating, as they can be flammable.

Not Recommended

- **Glass jars and bottles** — Regular glass is too thin to be used in a microwave, and can shatter.
- **Paper bags** — These are a fire hazard, except for popcorn bags that are designed for microwave use.
- **Styrofoam plates and cups** — These can melt and leave an unhealthy residue on food.
- **Plastic storage and food containers** — Containers such as margarine tubs can melt in the microwave.
- **Metal utensils** — These can damage your oven. Remove all metal before cooking.

Cooking Instructions

Testing Utensils

If you are not sure whether a dish is microwave-safe or not, you can perform this test:

1. Fill a 1 cup glass measuring cup with water and put it inside your oven, next to the dish you want to test.

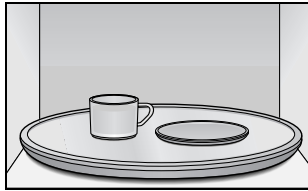

2. Press the **One Minute +** button once to heat them for one minute at High power.

The water should be warm and the dish you are testing should be cool. If the dish is warm, then it is absorbing microwave energy and is not acceptable for use in the microwave.

Cooking Techniques

Stirring

Stir foods such as casseroles and vegetables while cooking to distribute heat evenly. Food at the outside of the dish absorbs more energy and heats more quickly, so stir from the outside to the center. The oven will turn off when you open the door to stir your food. Press start to resume cooking.

Arrangement

Arrange unevenly shaped foods, such as chicken pieces or chops, with the thicker, meatier parts toward the outside of the turntable where they receive more microwave energy. To prevent overcooking, place thin or delicate parts toward the center of the turntable.

Shielding

Shield food with narrow strips of aluminum foil to prevent overcooking. Areas that need shielding include poultry wing-tips, the ends of poultry legs, and corners of square baking dishes. Use only small amounts of aluminum foil. Larger amounts can damage your oven.

Turning

Turn foods over midway through cooking to expose all parts to microwave energy. This is especially important with large items such as roasts.

Standing

Foods cooked in the microwave build up internal heat and continue to cook for a few minutes after the oven stops. Let foods stand to complete cooking, especially foods such as roasts and whole vegetables. Roasts need this time to complete cooking in the center without overcooking the outer areas. All liquids, such as soup or hot chocolate, should be shaken or stirred when cooking is complete. Let liquids stand a moment before serving. When heating baby food, stir well and test the temperature before serving.

Adding Moisture

- Microwave energy is attracted to water molecules. Food that is uneven in moisture content should be covered or allowed to stand so that the heat disperses evenly. Add a small amount of water to drier foods to assist cooking.

General Tips

- Dense foods, such as potatoes, take longer to heat than lighter foods. Foods with a delicate texture should be heated at a low power level to avoid becoming tough.
- Altitude and the type of cookware you are using can affect cooking time. When using a new recipe, use the minimum cooking time and check the food occasionally to prevent overcooking.
- Foods with a non-porous skin such as potatoes or hot dogs, should be pierced to prevent bursting.
- Frying with heating oil or fat is not recommended. Fat and oil can suddenly boil over and cause severe burns.
- Some ingredients heat faster than others. For example, the jelly inside a jelly doughnut will be hotter than the dough. Keep this in mind to avoid burns.
- Home canning in the microwave oven is not recommended because all harmful bacteria may not be destroyed by the microwave heating process.
- Although microwaves do not heat the cookware, the heat from the food is often transferred to the cookware. Always use pot holders when removing food from the microwave and instruct children to do the same.
- Making candy in the microwave is not recommended as candy can heat to very high temperatures. Keep this in mind to avoid injury.

Cooking Instructions

Auto Sensor Cook

The Auto Sensor allows you to cook your food automatically by detecting the amount of moistures generated from the food while cooking.

- When food is cooking, many kinds of moistures are generated. The Auto Sensor determines the proper time and power level by detecting these moistures from the food, eliminating the need to set the cooking time and power level.
- When you cover a container with its lid or plastic wrap during Sensor Cooking, the Auto Sensor will detect the moistures generated after the container has been saturated with steam.
- Shortly before cooking ends, the remaining cooking time will begin its count down. This will be a good time for you to rotate or stir the food for even cooking if it is necessary.
- Before auto sensor cooking food may be seasoned with herbs, spices or browning sauces. A word of caution though, salt or sugar may cause burn spots on food so these ingredients should be added after cooking.
- The More/Less function buttons(1=Less, 0=More are...) used to increase or decrease cooking time. You should use this function to adjust the degree of cooking to suit your personal taste.

Utensils & Cover For Sensor Cooking

- To obtain good cooking results with this function, follow the directions for selecting appropriate containers and covers in the charts in this book.
- Always use microwave-safe containers and cover them with their lids or with plastic wrap. When using plastic wrap, turn back one corner to allow steam to escape at the proper rate.
- Always cover with the lid intended for the utensil being used. If the utensil does not have its own lid, use plastic wrap.
- Fill containers at least half full.
- Foods that require stirring or rotating should be stirred or turned near the end of the Sensor Cook cycle, after the time has started to count down on the display.

Important

- It is not advisable to use the auto sensor cooking feature on a continuous cooking operation, i.e. one cooking operation immediately after another.
 - Install the oven in a well ventilated location for proper cooling and airflow and to ensure the sensor will operate accurately.
 - To avoid poor results, do not use the Auto sensor when the room ambient temperature is too high or too low.
 - Do not use volatile detergent to clean your oven. Moisture resulting from this detergent may affect the sensor.
 - Avoid placing the oven near high moisture or gas emitting appliances, since this will interfere with the proper performance of the Auto Sensor.
 - Always keep the inside of the oven clean. Wipe all spills with a damp cloth.
- This oven is designed for household use only.

Troubleshooting Guide

Before you call a repair person for your oven, check this list of possible problems and solutions.

Neither the oven's display nor the oven operate.

- Properly insert the plug into a grounded outlet.
- If the outlet is controlled by a wall switch, make sure the wall switch is turned on.
- Remove the plug from the outlet, wait ten seconds, then plug it in again.
- Reset the circuit breaker or replace any blown fuse.
- Plug another appliance into the outlet; if the other appliance doesn't work, have a qualified electrician repair the outlet.
- Plug the oven into a different outlet.

The oven's display works, but the power won't come on.

- Make sure the door is closed securely.
- Check to see if packing material or other material is stuck to the door seal.
- Check for door damage.
- Press Cancel twice and re-enter all cooking instructions.

The power goes off before the set time has elapsed.

- If there has not been a power blackout, remove the plug from the outlet, wait ten seconds, then plug it in again. If there was a power blackout, the time indicator will display " **▣▣:▣▣** " Reset the clock and any cooking instructions.
- Reset the circuit breaker or replace any blown fuse.

The food is cooking too slowly.

- Make sure the oven is on its own 20 amp circuit line. Operating another appliance on the same circuit can cause a voltage drop. If necessary, move the oven to its own circuit.

You see sparks or arcing.

- Remove any metallic utensils, cookware, or metal ties. If using foil, use only narrow strips and allow at least one inch between the foil and interior oven walls.

The turntable makes noises or sticks.

- Clean the turntable, roller ring and oven floor.
- Make sure the turntable and roller ring are positioned correctly.

Using your microwave causes TV or radio interference.

- This is similar to the interference caused by other small appliances, such as hair dryers. Move your microwave further away from other appliances, like your TV or radio.

Care and Cleaning

- Follow these instructions to clean and care for your oven.
- Keep the inside of the oven clean. Food particles and spilled liquids can stick to the oven walls, causing the oven to work less efficiently.
- Wipe up spills immediately. Use a damp cloth and mild soap. Do not use harsh detergents or abrasives.
- To help loosen baked on food particles or liquids, heat two cups of water (add the juice of one lemon if you desire to keep the oven fresh) in a four-cup measuring glass at **High** power for five minutes or until boiling. Let stand in the oven for one or two minutes.
- Remove the glass tray from the oven when cleaning the oven or tray. To prevent the tray from breaking, handle it carefully and do not put it in water immediately after cooking. Wash the tray carefully in warm sudsy water or in the dishwasher.
- Clean the outside surface of the oven with soap and a damp cloth. Dry with a soft cloth. To prevent damage to the operating parts of the oven, don't let water seep into the openings.
- Wash the door window with very mild soap and water. Be sure to use a soft cloth to avoid scratching.
- If steam accumulates inside or outside the oven door, wipe with a soft cloth. Steam can accumulate when operating the oven in high humidity and in no way indicates microwave leakage.
- Never operate the oven without food in it; this can damage the magnetron tube or glass tray. A good idea is to leave a cup of water in the oven when it is not in use to prevent damage if the oven is accidentally turned on.

Error Message

- If "Error1" and "Error3" are displayed, please let oven cool for at least 5 minutes. If these messages are displayed frequently, please call our service line.
- If you open the door on the way to sensing, "Error4" will be displayed.
- If "Error2" is displayed, please call our service line immediately.

Appendix

Specifications

Model Number	MS83HCE
Oven Cavity	0.8cuft (23 liter)
Controls	10 power levels, including defrost
Timer	99 minutes, 99 seconds
Power Source	230 V ~ 50 Hz
Power Output	850 Watts(IEC-705)
Outside Dimensions (W x H x D)	489 x 275 x 365 mm
Oven Cavity Dimensions (W x H x D)	330 x 211 x 329 mm
Net Weight	13.5 kg



ELECTRONICS

If you have any questions or comments relating to Samsung products, please contact the SAMSUNG customer care centre.

Tel : 1800-SAMSUNG (7267864)
www.samsung.com/sg