

15" Planer

(Model 22-785)
(Model 22-785X)

Shown with Delta
accessory planer stand
and roller extension tables



PART NO. 909593 - 06-07-05
Copyright © 2005 Delta Machinery



To learn more about DELTA MACHINERY
visit our website at: www.deltamachinery.com.

For Parts, Service, Warranty or other Assistance,

please call **1-800-223-7278** (In Canada call **1-800-463-3582**).

TABLE OF CONTENTS

IMPORTANT SAFETY INSTRUCTIONS	2
SAFETY GUIDELINES	3
GENERAL SAFETY RULES	4
ADDITIONAL SPECIFIC SAFETY RULES	5
FUNCTIONAL DESCRIPTION	7
CARTON CONTENTS	7
ASSEMBLY	8
OPERATION	10
TROUBLESHOOTING	18
MAINTENANCE	18
SERVICE	19
ACCESSORIES	19
WARRANTY	19
SERVICE CENTER LOCATIONSback cover

IMPORTANT SAFETY INSTRUCTIONS

▲WARNING Read and understand all warnings and operating instructions before using any tool or equipment. When using tools or equipment, basic safety precautions should always be followed to reduce the risk of personal injury. Improper operation, maintenance or modification of tools or equipment could result in serious injury and property damage. There are certain applications for which tools and equipment are designed. Delta Machinery strongly recommends that this product NOT be modified and/or used for any application other than for which it was designed.

If you have any questions relative to its application DO NOT use the product until you have written Delta Machinery and we have advised you.

Online contact form at www.deltamachinery.com

Postal Mail: Technical Service Manager
Delta Machinery
4825 Highway 45 North
Jackson, TN 38305

(IN CANADA: 125 Mural St. Suite 300, Richmond Hill, ON, L4B 1M4)

Information regarding the safe and proper operation of this tool is available from the following sources:

Power Tool Institute
1300 Sumner Avenue, Cleveland, OH 44115-2851
www.powertoolinstitute.org

National Safety Council
1121 Spring Lake Drive, Itasca, IL 60143-3201

American National Standards Institute, 25 West 43rd Street, 4 floor, New York, NY 10036 www.ansi.org
ANSI 01.1 Safety Requirements for Woodworking Machines, and

the U.S. Department of Labor regulations www.osha.gov

SAVE THESE INSTRUCTIONS!

SAFETY GUIDELINES - DEFINITIONS

It is important for you to read and understand this manual. The information it contains relates to protecting YOUR SAFETY and PREVENTING PROBLEMS. The symbols below are used to help you recognize this information.



- ▲ DANGER** Indicates an imminently hazardous situation which, if not avoided, will result in death or serious injury.
- ▲ WARNING** Indicates a potentially hazardous situation which, if not avoided, could result in death or serious injury.
- ▲ CAUTION** Indicates a potentially hazardous situation which, if not avoided, may result in minor or moderate injury.
- CAUTION** Used without the safety alert symbol indicates potentially hazardous situation which, if not avoided, may result in property damage.

CALIFORNIA PROPOSITION 65

▲ WARNING **SOME DUST CREATED BY POWER SANDING, SAWING, GRINDING, DRILLING, AND OTHER CONSTRUCTION ACTIVITIES** contains chemicals known to cause cancer, birth defects or other reproductive harm. Some examples of these chemicals are:

- lead from lead-based paints,
- crystalline silica from bricks and cement and other masonry products, and
- arsenic and chromium from chemically-treated lumber.

Your risk from these exposures varies, depending on how often you do this type of work. To reduce your exposure to these chemicals: work in a well ventilated area, and work with approved safety equipment, always wear **NIOSH/OSHA** approved, properly fitting face mask or respirator when using such tools.

GENERAL SAFETY RULES



⚠ WARNING READ AND UNDERSTAND ALL WARNINGS AND OPERATING INSTRUCTIONS BEFORE USING THIS EQUIPMENT. Failure to follow all instructions listed below, may result in electric shock, fire, and/or serious personal injury or property damage.

IMPORTANT SAFETY INSTRUCTIONS

- FOR YOUR OWN SAFETY, READ THE INSTRUCTION MANUAL BEFORE OPERATING THE MACHINE.** Learning the machine's application, limitations, and specific hazards will greatly minimize the possibility of accidents and injury.
- WEAR EYE AND HEARING PROTECTION. ALWAYS USE SAFETY GLASSES.** Everyday eyeglasses are NOT safety glasses. USE CERTIFIED SAFETY EQUIPMENT. Eye protection equipment should comply with ANSI Z87.1 standards. Hearing equipment should comply with ANSI S3.19 standards.
- WEAR PROPER APPAREL.** Do not wear loose clothing, gloves, neckties, rings, bracelets, or other jewelry which may get caught in moving parts. Nonslip footwear is recommended. Wear protective hair covering to contain long hair.
- DO NOT USE THE MACHINE IN A DANGEROUS ENVIRONMENT.** The use of power tools in damp or wet locations or in rain can cause shock or electrocution. Keep your work area well-lit to prevent tripping or placing arms, hands, and fingers in danger.
- MAINTAIN ALL TOOLS AND MACHINES IN PEAK CONDITION.** Keep tools sharp and clean for best and safest performance. Follow instructions for lubricating and changing accessories. Poorly maintained tools and machines can further damage the tool or machine and/or cause injury.
- CHECK FOR DAMAGED PARTS.** Before using the machine, check for any damaged parts. Check for alignment of moving parts, binding of moving parts, breakage of parts, and any other conditions that may affect its operation. A guard or any other part that is damaged **should be properly repaired or replaced.** Damaged parts can cause further damage to the machine and/or injury.
- KEEP THE WORK AREA CLEAN.** Cluttered areas and benches invite accidents.
- KEEP CHILDREN AND VISITORS AWAY.** Your shop is a potentially dangerous environment. Children and visitors can be injured.
- REDUCE THE RISK OF UNINTENTIONAL STARTING.** Make sure that the switch is in the "OFF" position before plugging in the power cord. In the event of a power failure, move the switch to the "OFF" position. An accidental start-up can cause injury.
- USE THE GUARDS.** Check to see that all guards are in place, secured, and working correctly to reduce the risk of injury.
- REMOVE ADJUSTING KEYS AND WRENCHES BEFORE STARTING THE MACHINE.** Tools, scrap pieces, and other debris can be thrown at high speed, causing injury.
- USE THE RIGHT MACHINE.** Don't force a machine or an attachment to do a job for which it was not designed. Damage to the machine and/or injury may result.
- USE RECOMMENDED ACCESSORIES.** The use of accessories and attachments not recommended by Delta may cause damage to the machine or injury to the user.
- USE THE PROPER EXTENSION CORD.** Make sure your extension cord is in good condition. When using an extension cord, be sure to use one heavy enough to carry the current your product will draw. An undersized cord will cause a drop in line voltage, resulting in loss of power and overheating. See the Extension Cord Chart for the correct size depending on the cord length and nameplate ampere rating. If in doubt, use the next heavier gauge. The smaller the gauge number, the heavier the cord.
- SECURE THE WORKPIECE.** Use clamps or a vise to hold the workpiece when practical. Loss of control of a workpiece can cause injury.
- FEED THE WORKPIECE AGAINST THE DIRECTION OF THE ROTATION OF THE BLADE, CUTTER, OR ABRASIVE SURFACE.** Feeding it from the other direction will cause the workpiece to be thrown out at high speed.
- DON'T FORCE THE WORKPIECE ON THE MACHINE.** Damage to the machine and/or injury may result.
- DON'T OVERREACH.** Loss of balance can make you fall into a working machine, causing injury.
- NEVER STAND ON THE MACHINE.** Injury could occur if the tool tips, or if you accidentally contact the cutting tool.
- NEVER LEAVE THE MACHINE RUNNING UNATTENDED. TURN THE POWER OFF.** Don't leave the machine until it comes to a complete stop. A child or visitor could be injured.
- TURN THE MACHINE "OFF", AND DISCONNECT THE MACHINE FROM THE POWER SOURCE** before installing or removing accessories, before adjusting or changing set-ups, or when making repairs. An accidental start-up can cause injury.
- MAKE YOUR WORKSHOP CHILDPROOF WITH PADLOCKS, MASTER SWITCHES, OR BY REMOVING STARTER KEYS.** The accidental start-up of a machine by a child or visitor could cause injury.
- STAY ALERT, WATCH WHAT YOU ARE DOING, AND USE COMMON SENSE. DO NOT USE THE MACHINE WHEN YOU ARE TIRED OR UNDER THE INFLUENCE OF DRUGS, ALCOHOL, OR MEDICATION.** A moment of inattention while operating power tools may result in injury.
- ⚠ WARNING USE OF THIS TOOL CAN GENERATE AND DISBURSE DUST OR OTHER AIRBORNE PARTICLES, INCLUDING WOOD DUST, CRYSTALLINE SILICA DUST AND ASBESTOS DUST.** Direct particles away from face and body. Always operate tool in well ventilated area and provide for proper dust removal. Use dust collection system wherever possible. Exposure to the dust may cause serious and permanent respiratory or other injury, including silicosis (a serious lung disease), cancer, and death. Avoid breathing the dust, and avoid prolonged contact with dust. Allowing dust to get into your mouth or eyes, or lay on your skin may promote absorption of harmful material. Always use properly fitting NIOSH/OSHA approved respiratory protection appropriate for the dust exposure, and wash exposed areas with soap and water.

ADDITIONAL SPECIFIC SAFETY RULES

▲ WARNING FAILURE TO FOLLOW THESE RULES MAY RESULT IN SERIOUS PERSONAL INJURY.

1. **DO NOT OPERATE THIS MACHINE** until it is completely assembled and installed according to the instructions. A machine incorrectly assembled can cause serious injury.
2. **OBTAIN ADVICE** from your supervisor, instructor, or another qualified person if you are not thoroughly familiar with the operation of this machine. Knowledge is safety.
3. **FOLLOW ALL WIRING CODES** and recommended electrical connections to prevent shock or electrocution.
4. **KEEP KNIVES SHARP** and free from rust and pitch. Dull or rusted knives work harder and can cause kickback.
5. **NEVER TURN THE MACHINE “ON”** before clearing the table of all objects (tools, scraps of wood, etc.). Flying debris can cause serious injury.
6. **NEVER TURN THE MACHINE “ON”** with the workpiece contacting the cutterhead. Kickback can occur.
7. **SECURE THE MACHINE TO A SUPPORTING SURFACE** to prevent the machine from sliding, walking or tipping over.
8. **PROPERLY SECURE THE KNIVES IN THE CUTTERHEAD** before turning the power “ON”. Loose blades may be thrown out at high speeds causing serious injury.
9. **LOCK THE SPEED SETTING SECURELY** before feeding the workpiece through the machine. Changing speeds while planing can cause kickback.
10. **AVOID AWKWARD OPERATIONS AND HAND POSITIONS.** A sudden slip could cause a hand to move into the knives.
11. **KEEP ARMS, HANDS, AND FINGERS** away from the cutterhead, the chip exhaust opening, and the feed rollers to prevent severe cuts.
12. **NEVER REACH INTO THE CUTTERHEAD AREA** while the machine is running. Your hands can be drawn into the knives.
13. **DO NOT STAND IN LINE OF THE WORKPIECE.** Kickback can cause injury.
14. **ALLOW THE CUTTERHEAD TO REACH FULL SPEED** before feeding a workpiece. Changing speeds while planing can cause kickback.
15. **WHEN PLANING BOWED STOCK,** place the concave (cup down) side of the stock on the table and cut with the grain to prevent kickback.
16. **DO NOT FEED A WORKPIECE** that is warped, contains knots, or is embedded with foreign objects (nails, staples, etc.). Kickback can occur.
17. **DO NOT FEED A SHORT, THIN, OR NARROW WORKPIECE INTO THE MACHINE.** Your hands can be drawn into the knives and/or the workpiece can be thrown at high speeds. See the “OPERATION” section of this instruction manual for details.
18. **DO NOT FEED A WORKPIECE** into the outfeed end of the machine. The workpiece will be thrown out of the opposite side at high speeds.
19. **REMOVE SHAVINGS ONLY** with the power “OFF” to prevent serious injury.
20. **PROPERLY SUPPORT LONG OR WIDE WORKPIECES.** Loss of control of the workpiece can cause serious injury.
21. **NEVER PERFORM LAYOUT, ASSEMBLY** or set-up work on the table/work area when the machine is running. Serious injury will result.
22. **TURN THE MACHINE “OFF”, DISCONNECT IT FROM THE POWER SOURCE,** and clean the table/work area before leaving the machine. **LOCK THE SWITCH IN THE “OFF” POSITION** to prevent unauthorized use. Someone else might accidentally start the machine and cause injury to themselves or others.
23. **ADDITIONAL INFORMATION** regarding the safe and proper operation of power tools (i.e. a safety video) is available from the Power Tool Institute, 1300 Sumner Avenue, Cleveland, OH 44115-2851 (www.powertoolinstitute.com). Information is also available from the National Safety Council, 1121 Spring Lake Drive, Itasca, IL 60143-3201. Please refer to the American National Standards Institute ANSI 01.1 Safety Requirements for Woodworking Machines and the U.S. Department of Labor Regulations.

SAVE THESE INSTRUCTIONS.
Refer to them often and use them to instruct others.

POWER CONNECTIONS

A separate electrical circuit should be used for your machines. This circuit should not be less than #12 wire and should be protected with a 20 Amp time lag fuse. If an extension cord is used, use only 3-wire extension cords which have 3-prong grounding type plugs and matching receptacle which will accept the machine's plug. Before connecting the machine to the power line, make sure the switch (s) is in the "OFF" position and be sure that the electric current is of the same characteristics as indicated on the machine. All line connections should make good contact. Running on low voltage will damage the machine.

⚠ DANGER DO NOT EXPOSE THE MACHINE TO RAIN OR OPERATE THE MACHINE IN DAMP LOCATIONS.

MOTOR SPECIFICATIONS

Your machine is wired for 240 volts, 60 HZ alternating current. Before connecting the machine to the power source, make sure the switch is in the "OFF" position.

GROUNDING INSTRUCTIONS

⚠ DANGER THIS MACHINE MUST BE GROUNDED WHILE IN USE TO PROTECT THE OPERATOR FROM ELECTRIC SHOCK.

1. All grounded, cord-connected machines:

In the event of a malfunction or breakdown, grounding provides a path of least resistance for electric current to reduce the risk of electric shock. This machine is equipped with an electric cord having an equipment-grounding conductor and a grounding plug. The plug must be plugged into a matching outlet that is properly installed and grounded in accordance with all local codes and ordinances.

Do not modify the plug provided - if it will not fit the outlet, have the proper outlet installed by a qualified electrician.

Improper connection of the equipment-grounding conductor can result in risk of electric shock. The conductor with insulation having an outer surface that is green with or without yellow stripes is the equipment-grounding conductor. If repair or replacement of the electric cord or plug is necessary, do not connect the equipment-grounding conductor to a live terminal.

Check with a qualified electrician or service personnel if the grounding instructions are not completely understood, or if in doubt as to whether the machine is properly grounded.

Use only 3-wire extension cords that have 3-prong grounding type plugs and matching 3-conductor receptacles that accept the machine's plug, as shown in Fig. A.

Repair or replace damaged or worn cord immediately.

3. Grounded, cord-connected machines intended for use on a supply circuit having a nominal rating between 150 - 250 volts, inclusive:

If the machine is intended for use on a circuit that has an outlet that looks like the one illustrated in Fig. C, the machine will have a grounding plug that looks like the plug illustrated in Fig. C. Make sure the machine is connected to an outlet having the same configuration as the plug. No adapter is available or should be used with this machine. If the machine must be re-connected for use on a different type of electric circuit, the re-connection should be made by qualified service personnel; and after re-connection, the machine should comply with the National Electric Code and all local codes and ordinances.

NOTE: In Canada, the use of a temporary adapter is not permitted by the Canadian Electric Code.

⚠ DANGER IN ALL CASES, MAKE CERTAIN THAT THE RECEPTACLE IN QUESTION IS PROPERLY GROUNDED. IF YOU ARE NOT SURE, HAVE A QUALIFIED ELECTRICIAN CHECK THE RECEPTACLE.

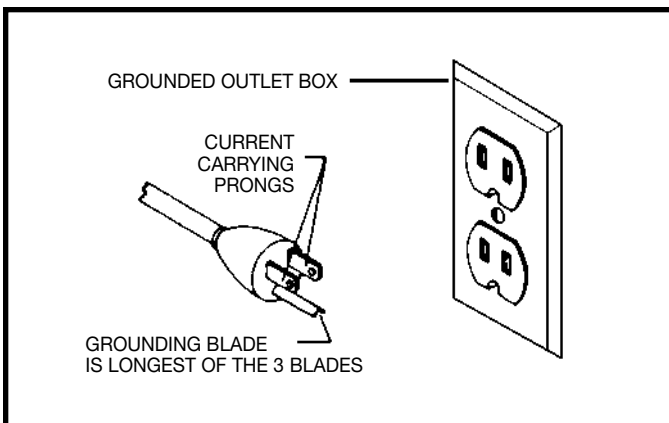

Fig. A

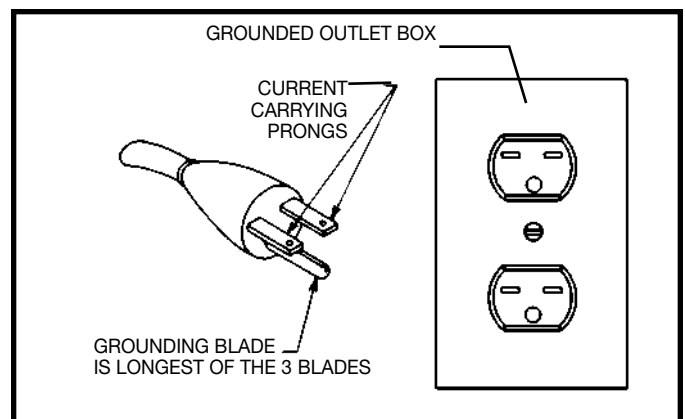

Fig. C

EXTENSION CORDS

⚠ WARNING Use proper extension cords. Make sure your extension cord is in good condition and is a 3-wire extension cord which has a 3-prong grounding type plug and matching receptacle which will accept the machine's plug. When using an extension cord, be sure to use one heavy enough to carry the current of the machine. An undersized cord will cause a drop in line voltage, resulting in loss of power and overheating. Fig. D-1, shows the correct gauge to use depending on the cord length. If in doubt, use the next heavier gauge. The smaller the gauge number, the heavier the cord.

MINIMUM GAUGE EXTENSION CORD			
RECOMMENDED SIZES FOR USE WITH STATIONARY ELECTRIC MACHINES			
Ampere Rating	Volts	Total Length of Cord in Feet	Gauge of Extension Cord
0-6	240	up to 50	18 AWG
0-6	240	50-100	16 AWG
0-6	240	100-200	16 AWG
0-6	240	200-300	14 AWG
6-10	240	up to 50	18 AWG
6-10	240	50-100	16 AWG
6-10	240	100-200	14 AWG
6-10	240	200-300	12 AWG
10-12	240	up to 50	16 AWG
10-12	240	50-100	16 AWG
10-12	240	100-200	14 AWG
10-12	240	200-300	12 AWG
12-16	240	up to 50	14 AWG
12-16	240	50-100	12 AWG
12-16	240	GREATER THAN 100 FEET NOT RECOMMENDED	

Fig. D-1

FUNCTIONAL DESCRIPTION

FOREWORD

Delta Models 22-785 and 22-785X are 15" (381mm) Planers with adjustable feed rate for optimum planing under load. They have the following cutting capacities; 15" (381mm) width, 6½" (165mm) thickness and 1/8" (5mm) depth of cut.

NOTICE: The photo on the manual cover illustrates the current production model. All other illustrations contained in the manual are representative only and may not depict the actual labeling or accessories included. These are intended to illustrate technique only.

CARTON CONTENTS

Your new 15" Planer is shipped complete in one box. The machine is very heavy. Care must be taken when removing the machine. (See the section "LIFTING THE MACHINE").

Figure 3 Illustrates the loose items supplied with your machine.

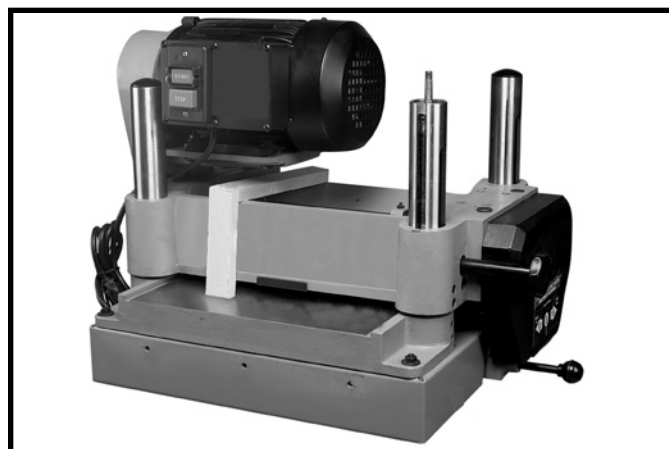

Fig. 2

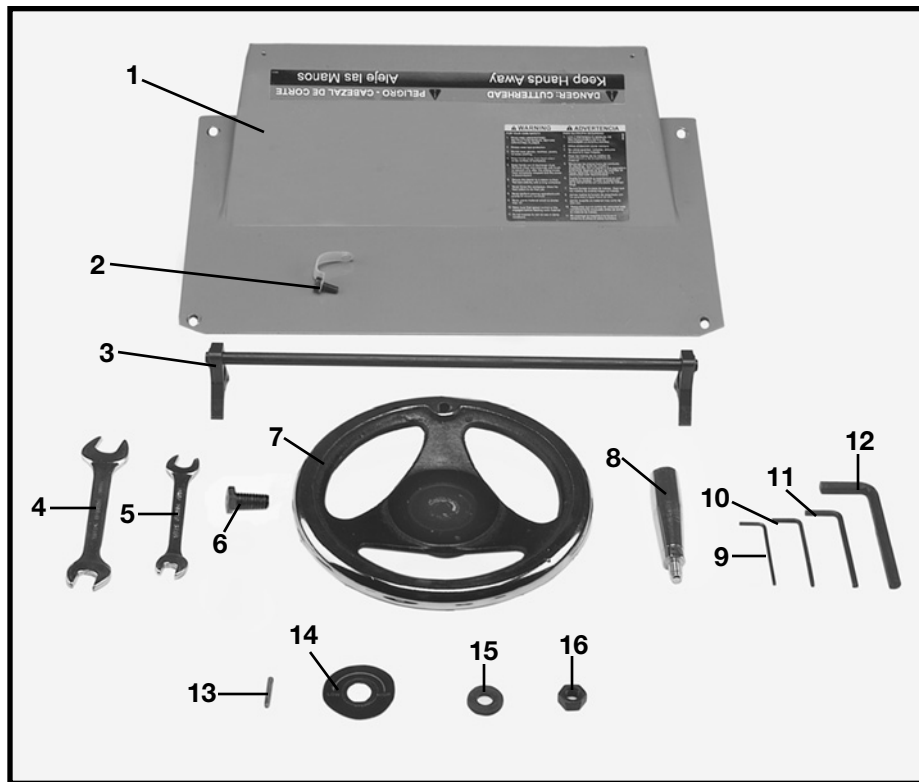

Fig. 3

- | | |
|-------------------------------------------------------------------------|---------------------------------------------------------|
| 1 - Top cover | 10 - Hex wrench (3mm) |
| 2 - Cord clamp | 11 - Hex wrench (5mm) |
| 3 - Knife setting gage | 12 - Hex wrench (6mm) |
| 4 - Open end wrench (14 and 17mm) | 13 - Key for raising and lowering handwheel |
| 5 - Open end wrench (10 and 12mm) | 14 - Decal for raising and lowering handwheel |
| 6 - M6x1x16mm hex flange screw (4) - for fastening top cover to machine | 15 - M10 flat washer for raising and lowering handwheel |
| 7 - Raising and lowering handwheel | 16 - M10x1.5 hex nut for raising and lowering handwheel |
| 8 - Handle for raising and lowering handwheel | |
| 9 - Hex wrench (2.5mm) | |

UNPACKING AND CLEANING

Carefully unpack the machine and all loose items from the shipping container(s). Remove the protective coating from all unpainted surfaces. This coating may be removed with a soft cloth moistened with kerosene (do not use acetone, gasoline or lacquer thinner for this purpose). After cleaning, cover the unpainted surfaces with a good quality household floor paste wax.

ASSEMBLY

ASSEMBLY TOOLS REQUIRED

- | | |
|-----------------------------------------------|----------------------------------------------|
| 1) - Open end wrench (10 and 12mm) - provided | 5) - Hex wrench (3mm) - provided |
| 2) - Open end wrench (14 and 17mm) - provided | 6) - Hex wrench (2.5mm) - provided |
| 3) - Hex wrench (6mm) - provided | 7) - 10, 12, 14, 17mm Sockets - not provided |
| 4) - Hex wrench (5mm) - provided | 8) - 2 - 2 x 4's - not provided |

ASSEMBLY TIME ESTIMATE

Assembly for this machine takes approximately 2 hours.

⚠ WARNING FOR YOUR OWN SAFETY, DO NOT CONNECT THE MACHINE TO THE POWER SOURCE UNTIL THE MACHINE IS COMPLETELY ASSEMBLED AND YOU READ AND UNDERSTAND THE ENTIRE INSTRUCTION MANUAL.

CUTTINGHEAD RAISING AND LOWERING HANDWHEEL

1. Insert key (A) Fig. 7, into keyway (B) of raising and lowering shaft.
2. Assemble handwheel (C) Fig. 8, to raising and lowering shaft as shown. Make sure key, which was assembled to shaft in **STEP 1**, is engaged with keyway in hub of handwheel (C).
3. Assemble decal (D) Fig. 8, to raising and lowering shaft as shown.
4. Fasten handwheel (C) Fig. 8, to raising and lowering shaft using an M10 flat washer (E) and an M10 hex nut (F) supplied.
5. Assemble handle (G) Fig. 8, to handwheel (C) as shown.
6. Loosen two head locking knobs, one of which is shown at (G) Fig. 9, and turn handwheel assembly (H) clockwise to raise head assembly. Remove the protective shipping block (J).

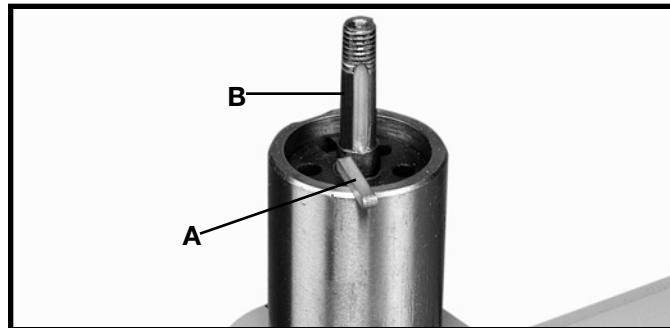

Fig. 7

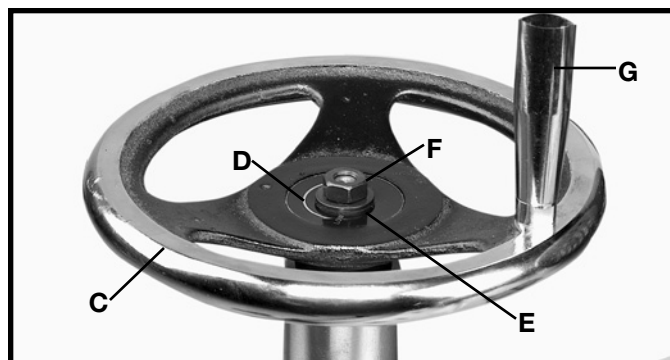

Fig. 8

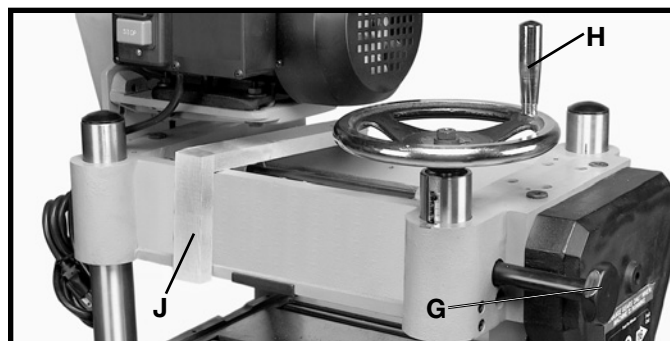

Fig. 9

LIFTING THE MACHINE

1. IMPORTANT: CARE MUST BE TAKEN WHEN LIFTING THE MACHINE ONTO A STAND OR WORKBENCH. THE PLANER IS VERY HEAVY AND A MINIMUM OF FOUR PEOPLE WILL BE REQUIRED TO LIFT THE MACHINE AS FOLLOWS:

2. Raise the cuttinghead (A) Fig. 10, by turning the raising and lowering handwheel (B) clockwise, and insert two 6 or 8 foot long 2 x 4's (C) between the cuttinghead and table as shown. Lower the cuttinghead just until it touches the 2 x 4 's (C) Fig. 10, so that they are positioned solidly between the table and cuttinghead. Then with two people on each end of the 2 x 4's, move the machine to its desired location.

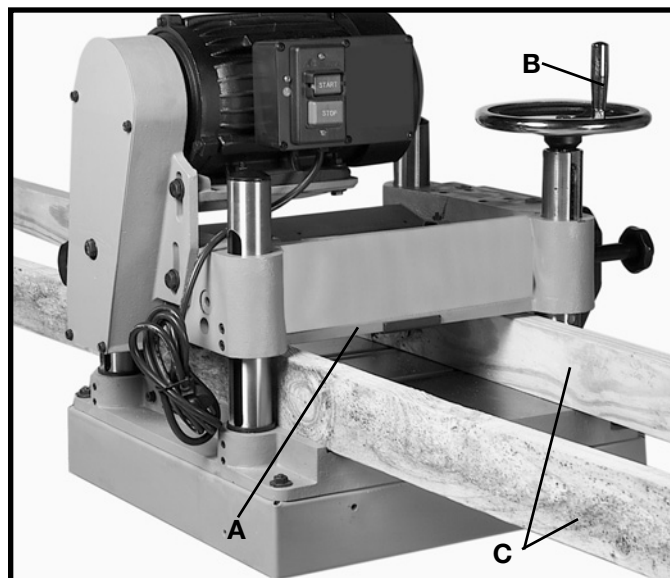

Fig. 10

ASSEMBLING TOP COVER AND DUST CHUTE

1. Fasten the top cover and dust chute (A) Fig. 16, to the top of the planer, as shown, using the three M6x16mm screws (B) supplied. **IMPORTANT:** The dust chute opening (C) must point to the rear as shown.

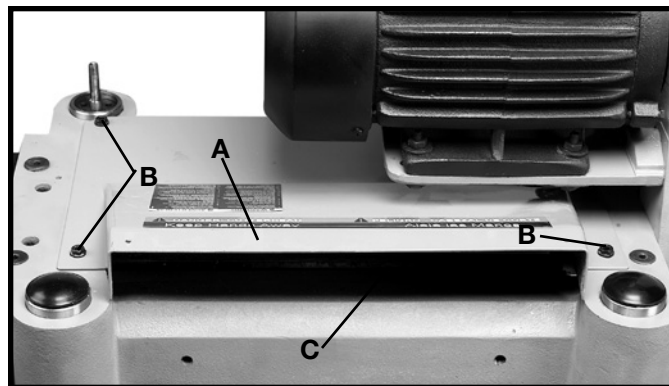

Fig. 16

2. Fasten the left corner of the cover to the top of the planer using the remaining M6x16mm screw (D) Fig. 17, and cord clamp (E). **NOTE:** The motor cord (F) must be inserted and positioned into the cord clamp as shown.

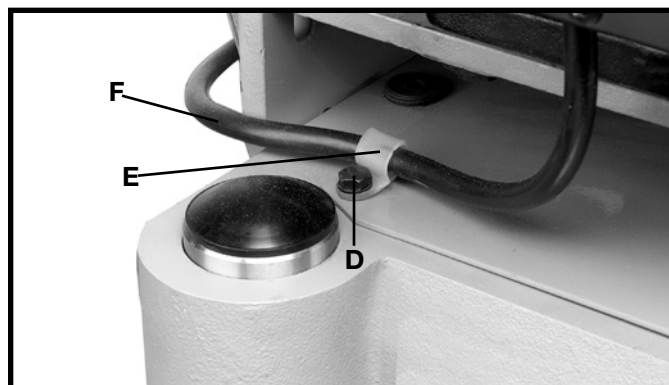

Fig. 17

OPERATING CONTROLS AND ADJUSTMENTS

OPERATIONAL CONTROLS AND ADJUSTMENTS

STARTING AND STOPPING PLANER

1. The on/off switch is located on the front of the planer. To turn the machine “ON”, push the START button (A) Fig. 18.
2. To turn the machine “OFF”, push the STOP button (B) Fig. 18.

⚠ WARNING MAKE SURE THAT THE SWITCH IS IN THE “OFF” POSITION BEFORE PLUGGING IN THE POWER CORD. IN THE EVENT OF A POWER FAILURE, MOVE THE SWITCH TO THE “OFF” POSITION. AN ACCIDENTAL START-UP CAN CAUSE INJURY.

LOCKING SWITCH IN THE “OFF” POSITION

IMPORTANT: When the machine is not in use, the switch should be locked in the “OFF” position to prevent unauthorized use, using a padlock (C) Fig. 19 with a 3/16” diameter shackle.

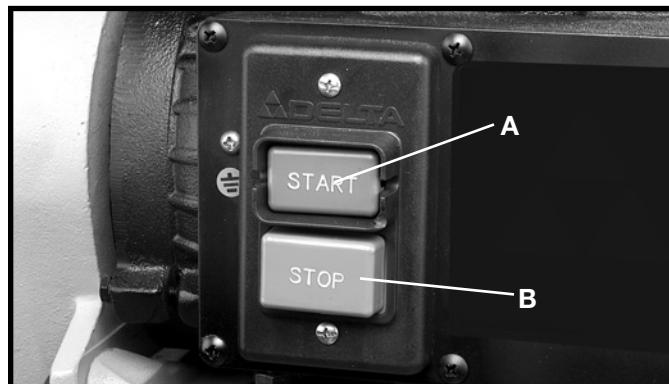

Fig. 18

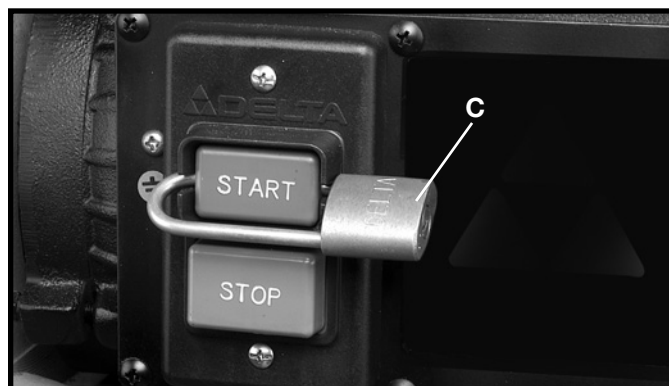

Fig. 19

DEPTH OF CUT ADJUSTMENT

The depth of cut on your planer is controlled by raising or lowering the head assembly (A) Fig. 22, which contains the cutterhead and feed rollers. The head assembly (A) moves on four precision ground steel columns, three of which are shown at (B). To adjust for depth of cut, simply loosen the two head assembly lock knobs, one of which is shown at (C), and turn the head raising and lowering handwheel (D). Turning the handwheel (D) clockwise, raises the head assembly and counterclockwise, lowers the head assembly. Then tighten the two head assembly lock knobs (C).

The maximum depth of cut when planing stock narrower than 6 inches wide is $\frac{3}{16}$ " when the stock is run through the planer on one side or the other of the cutterhead. A limiter (E) Fig. 22, is provided to limit the depth of cut to $\frac{1}{8}$ " on stock wider than 6 inches.

FEED SPEED CONTROL

CAUTION CHANGE SPEEDS ONLY WHILE THE MOTOR IS RUNNING. DO NOT CHANGE SPEEDS WHILE PLANING.

Two feed roll speeds of 16 and 30 feet per minute are provided with your planer. Generally speaking, the slower feed rate provides more cuts per inch, thus a finer, smoother finish of the workpiece is obtained. A good rule to follow would be to operate the machine at the faster feed rate for general planing and switch to the slower feed rate for the final finished dimension of the workpiece. When planing wide stock (wider than 8") particularly in hard wood, the slower feed speed is more desirable as there is less strain on the motor and a better finish is obtained since there are more cuts per inch of stock length.

When the shifter knob (A) Fig. 24, is pushed all the way in as shown, the feed speed will be 30 feet per minute.

When the shifter knob (A) Fig. 25, is pulled all the way out as shown, the feed speed will be 16 feet per minute.



Fig. 25

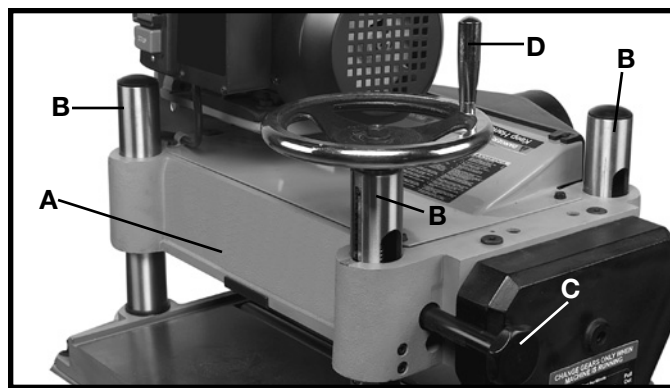

Fig. 22

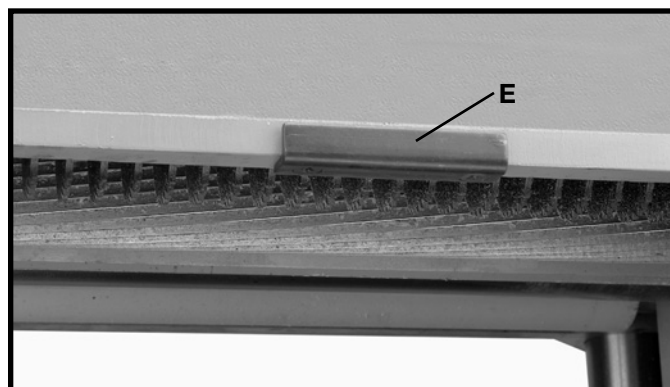

Fig. 23



Fig. 24

When the shifter knob (A) Fig. 26, is in the center (neutral) position as shown, the machine will stop feeding.



Fig. 26

ANTI-KICKBACK FINGERS

⚠ WARNING WHEN INSPECTING AND CLEANING THE ANTI-KICKBACK FINGERS, MAKE SURE THE MACHINE IS DISCONNECTED FROM THE POWER SOURCE.

A series of anti-kickback fingers (A) Fig. 27, are provided on the infeed end of the planer, to prevent kickback of the workpiece during the planing operation. These anti-kickback fingers operate by gravity and no adjustment is required. It is necessary, however, to inspect them occasionally to make sure they are free of gum and pitch and that they move independently and operate correctly.

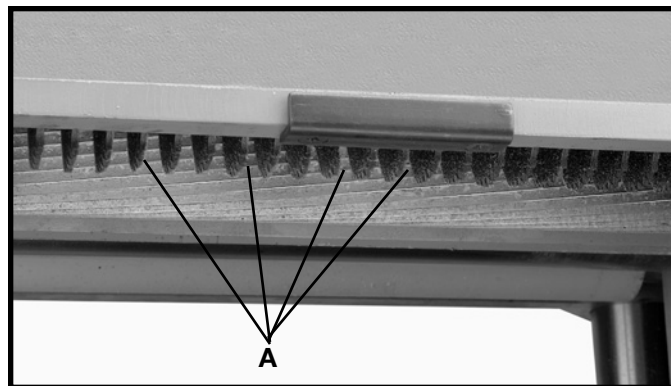

Fig. 27

ADJUSTING BELT TENSION

⚠ WARNING DISCONNECT MACHINE FROM POWER SOURCE.

1. Remove four screws (A) Fig. 28, and remove the belt and pulley guard cover (B).
2. Place a 2 x 4 (D) Fig. 29, between the motor plate and the top of the head casting as shown.
3. Loosen the four screws (C) Fig. 29, and pry up on motor plate until correct belt tension is obtained. Correct tension is when there is approximately 1/4" deflection in the center span of the belts using light finger pressure. Then tighten the three screws (C) and replace belt and pulley guard cover (B) Fig. 28.

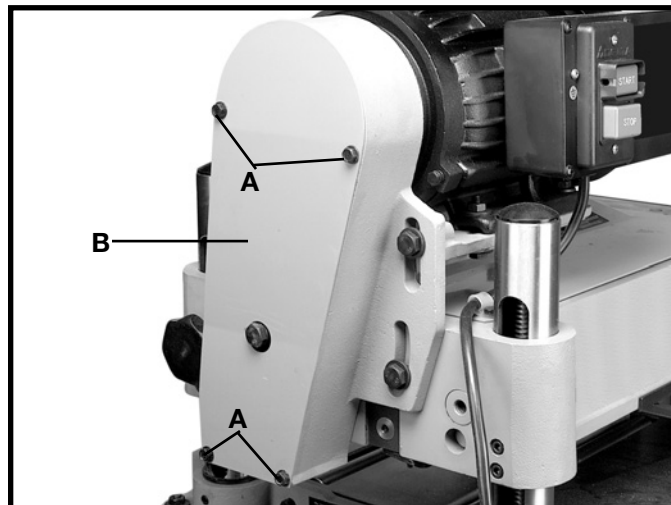

Fig. 28

CHECKING, ADJUSTING AND REPLACING KNIVES

⚠ WARNING IF THE KNIVES ARE TO BE REMOVED FOR SHARPENING OR REPLACEMENT, EXTREME CARE SHOULD BE TAKEN AS THE KNIVES ARE VERY SHARP. TO REMOVE THE KNIVES, WEAR GLOVES AND PROCEED AS FOLLOWS:

1. **⚠ WARNING** DISCONNECT MACHINE FROM POWER SOURCE.
2. Remove four screws (A) Fig. 30 and Fig. 31, and remove top cover (B).
3. Loosen two screws (C) Fig. 32, and pivot motor assembly (D) to the front. **NOTE:** Belt tension is not disturbed when pivoting the motor forward.



Fig. 29



Fig. 30

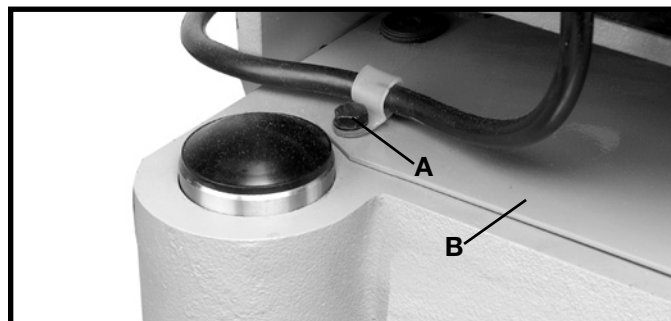

Fig. 31

4. Remove the three screws (E) Fig. 34, and remove the chip deflector (F).

5. To check and adjust the knives, proceed as follows:

A. Carefully place the knife setting gage (G) Fig. 35, on the cutterhead as shown.

B. When the knives are adjusted correctly, the knife (H) Fig. 36, should just contact the bottom of the gage (J), at each end of the gage. Check the remaining two knives in the same manner.

C. To adjust the knife that must be reset, loosen all five locking screws, two of which are shown at (K) Fig. 37, by turning them clockwise into the lock bar. Then using the wrench supplied, turn allen screw (L) Fig. 37, counterclockwise to lower or clockwise to raise the knife on each end of the cutterhead until the cutting edge of knife (H) Fig. 36, just touches the bottom of the gage (J). Then snug up the knife locking bar by lightly backing out the five locking screws, two of which are shown at (K) Fig. 37, against the knife slot. **IMPORTANT: AT THIS TIME, ONLY TIGHTEN THE KNIFE INTO THE SLOT ENOUGH TO HOLD IT IN POSITION.**

D. If additional knives must be reset, repeat **STEP C**.

E. After all three knives are set, back out and tighten the five locking screws, two of which are shown at (K) Fig. 37, against the slot, starting with the end screws first, then the center screws until the knife is securely held in the cutterhead. Tighten the remaining two knives in the same manner.

5. **⚠WARNING** IF THE KNIVES ARE TO BE REMOVED FOR SHARPENING OR REPLACEMENT, EXTREME CARE SHOULD BE TAKEN AS THE KNIVES ARE VERY SHARP. TO REMOVE THE KNIVES, WEAR GLOVES AND PROCEED AS FOLLOWS:

A. Remove the knife (M) Fig. 37, locking bar (N), and locking screws (K) from the cutterhead. Repeat this process for the two remaining knives, locking bars, and locking screws.

B. Thoroughly clean the knives, knife slots, locking bars and locking screws. Check the screws. If the threads appear worn or stripped or if the heads are becoming rounded, replace them.

C. Insert locking bars, knives and screws into all three slots in the cutterhead. Back out the locking screws, two of which are shown at (K) Fig. 37, just enough to hold all three knives in the cutterhead.

D. Adjust all three knives as explained under **STEP 4**.

6. **IMPORTANT:** After knives have been adjusted, replace chip deflector that was removed in **STEP 3**, top cover that was removed in **STEP 1** and return motor assembly to the upright position. The motor assembly was pivoted forward in **STEP 2**.

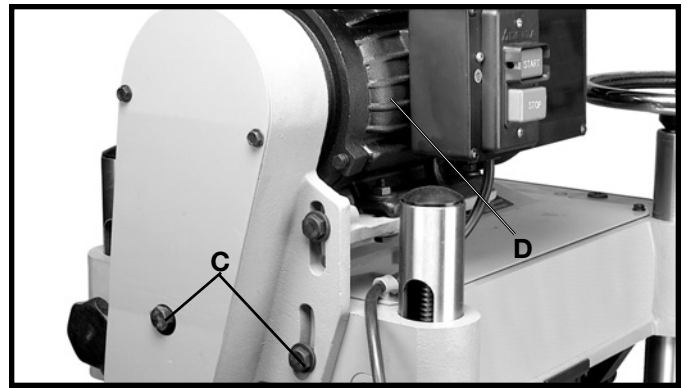

Fig. 32

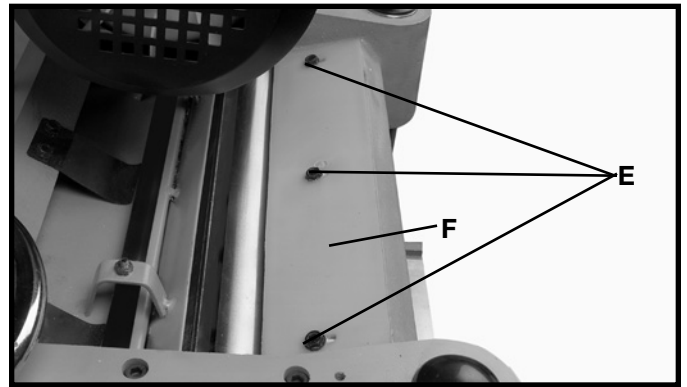

Fig. 34

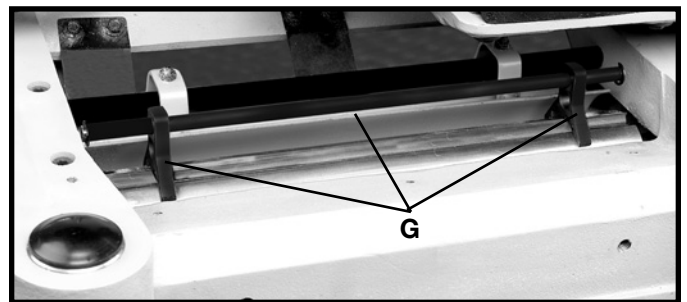

Fig. 35

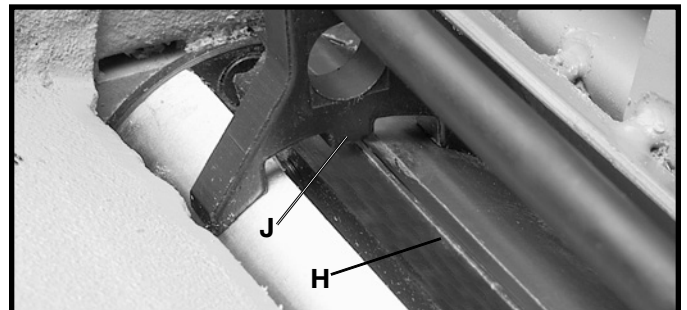

Fig. 36

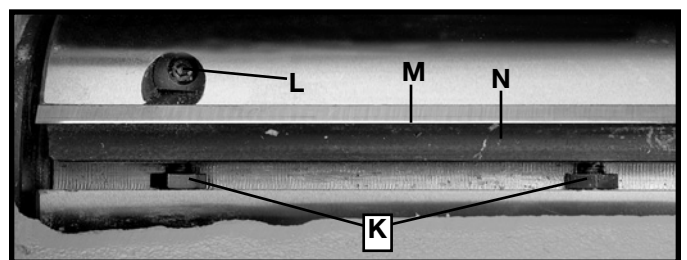

Fig. 37

CONSTRUCTING GAGE BLOCK

In order to check and adjust the height of the chipbreaker, infeed and outfeed roll and adjust the cutterhead parallel to the table, you will need a homemade gage block made of hard wood. This gage block can be constructed by following the dimensions shown in Fig. 38.

ADJUSTING HEIGHT OF CHIPBREAKER

The chipbreaker extends down around the front of the cutterhead and raises as stock is fed through the planer. The chipbreaker “breaks or curls” the chips as they leave the cutterhead and the bottom edge of the chipbreaker helps hold the stock flat down on the table during the planing operation. The bottom of the chipbreaker must be parallel to the knives and set 0.020" below the cutting circle. To check and adjust, proceed as follows:

⚠ WARNING DISCONNECT MACHINE FROM POWER SOURCE.

1. Make certain the knives are adjusted properly as explained under “CHECKING, ADJUSTING AND REPLACING KNIVES.”
2. Place the gage block (A) Fig. 39, on the table directly under the cutterhead as shown. Using a 0.020" feeler gage (B) placed on top of the gage block, raise or lower the head assembly until one of the knives just touches the feeler gage when the knife is at its lowest point. Then lock the head assembly in this position.
3. Place the gage block (A) Fig. 40, minus the feeler gage, under one end of the chipbreaker (C), as shown. The bottom of the chipbreaker (C) should just touch the top of the gage block, as shown.
4. If the height of the chipbreaker must be adjusted, remove the top cover of the machine. Loosen nut (D) Fig. 41, and turn screw (E) until that end of the chipbreaker is properly adjusted. Then tighten nut (D).
5. Place the gage block on the other end of the chipbreaker and if an adjustment is necessary loosen nut (F) Fig. 41, and turn adjusting screw (G).

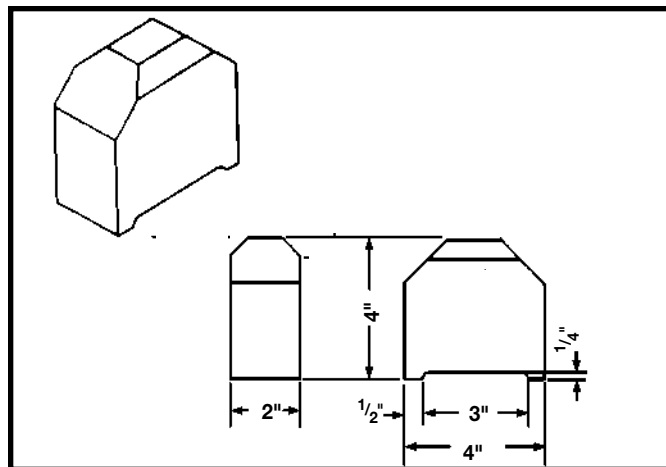

Fig. 38

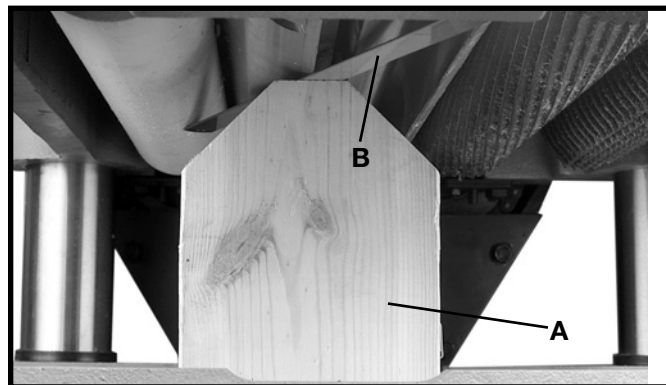

Fig. 39

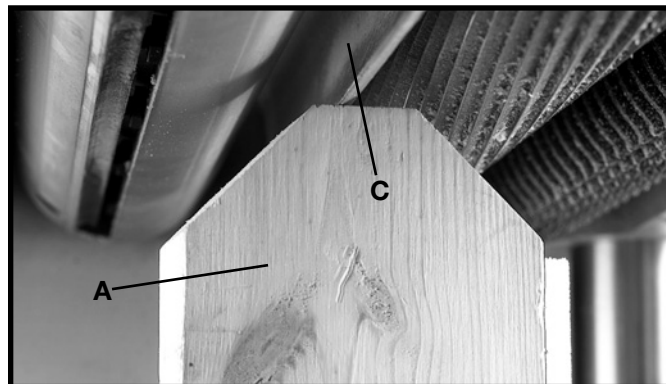

Fig. 40

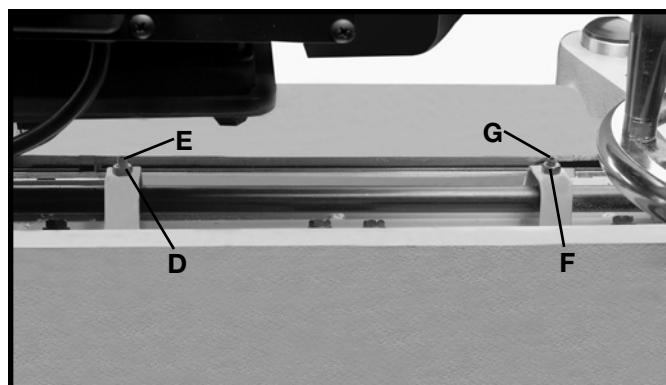

Fig. 41

ADJUSTING HEIGHT OF INFEEED ROLLER

The infeed roller is adjusted at the factory at **0.040" below the cutting circle**. To check and adjust the height of the infeed roller, proceed as follows:

⚠ WARNING DISCONNECT MACHINE FROM POWER SOURCE.

1. Make sure the knives are adjusted properly as explained under **“CHECKING, ADJUSTING AND REPLACING KNIVES.”**
2. Place the gage block (A) Fig. 42, on the table directly underneath the cutterhead, as shown. Using a 0.040" feeler gage (B) placed on top of the gage block, raise or lower the head assembly until one of the knives just touches the feeler gage when the knife is at its lowest point. Then tighten the head locking knobs.
3. Move the gage block (A) Fig. 43, minus the feeler gage, under one end of the infeed roller (C). The bottom of the infeed roller (C) should just touch the top of the gage block (A), as shown.
4. If the height of the infeed roller must be adjusted, loosen nut (D) Fig. 43, and turn adjusting screw (E) until that end of the infeed roller just touches the top of the gage block. Then tighten nut (D).
5. Repeat this adjustment with the gage block on the opposite end of the infeed roller.

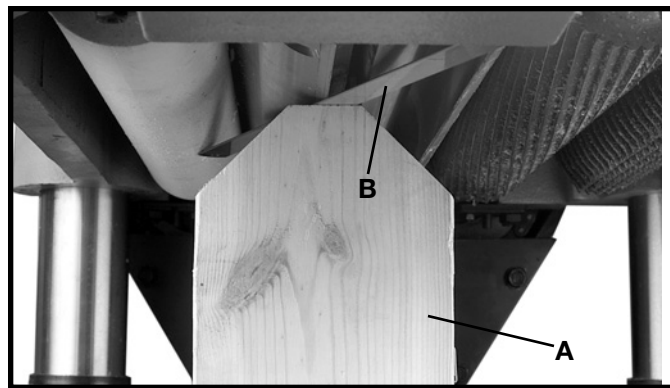

Fig. 42

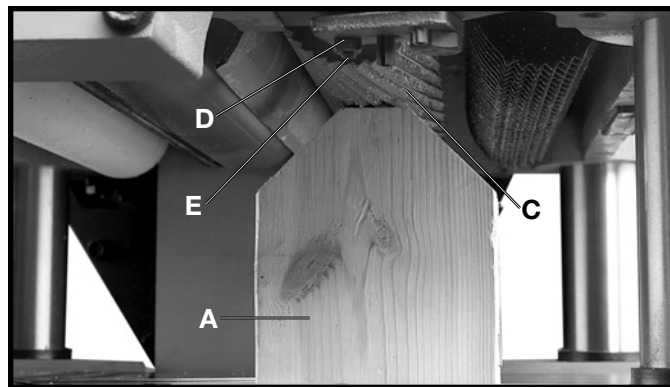

Fig. 43

ADJUSTING HEIGHT OF OUTFEED ROLLER

The outfeed roller is adjusted at the factory to be **0.040" below the cutting circle**. To check and adjust the height of the outfeed roller, proceed as follows:

⚠ WARNING DISCONNECT MACHINE FROM POWER SOURCE.

1. Make sure the knives are adjusted properly as explained under **“CHECKING, ADJUSTING AND REPLACING KNIVES.”**
2. Place the gage block (A) Fig. 44, on the table directly underneath the cutterhead, as shown. Using a 0.040" feeler gage (B) Fig. 44, placed on top of the gage block as shown, raise or lower the head assembly until one of the knives just touches the feeler gage when the knife is at its lowest point. Then tighten the head locking knobs.
3. Move the gage block (A) Fig. 45, minus the feeler gage, under the end of the outfeed roller (C). The bottom of the out-feed roller (C) should just touch the top of the gage block (A).
4. If the height of the outfeed roller must be adjusted, loosen nut (D) Fig. 45, and turn screw (E) until the outfeed roller is properly adjusted.
5. Repeat this adjustment procedure on the opposite end of the outfeed roller in the same manner.

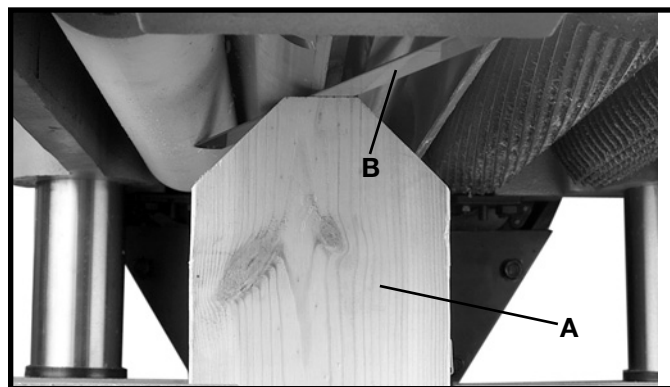

Fig. 44

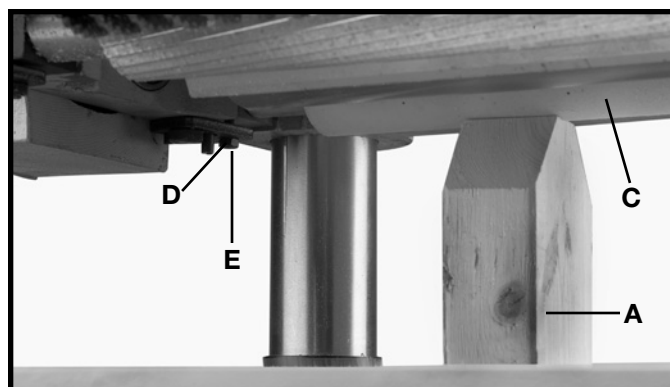

Fig. 45

ADJUSTING SPRING TENSION OF INFEEED AND OUTFEED ROLLERS

The infeed and outfeed rollers are those parts of your planer that feed the stock while it is being planed. The feed rollers are under spring tension and this tension must be sufficient to feed the stock uniformly through the planer without slipping but should not be too tight that it causes damage to the board. The tension should also be equal at both ends of each roller.

To adjust the spring tension of the infeed roller, turn two screws, one of which is shown at (A) Fig. 46. The other screw is located on the opposite side of the machine. A good starting point to use in setting the spring tension of the infeed roller is to adjust the two screws (A) until there are **FOUR** threads showing above the table casting. To increase or decrease the spring tension further, adjust screws (A).

To adjust the spring tension of the outfeed roller, turn two screws, one of which is shown at (B) Fig. 46. The other screw is located on the opposite side of the machine. A good starting point to use in setting the spring tension of the outfeed roller is to adjust the two screws (B) until there is **ONE** thread showing above the table casting. To increase or decrease the spring tension further, adjust screws (B).

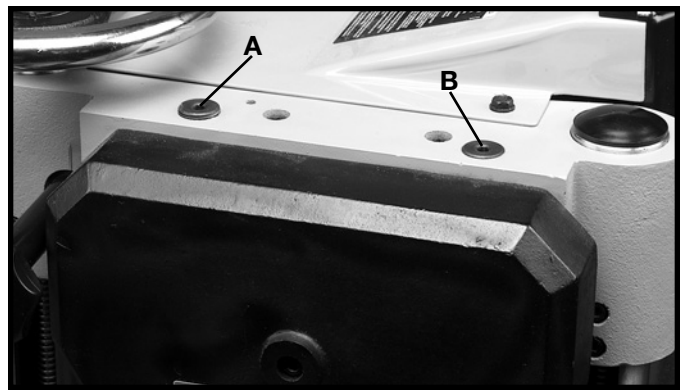

Fig. 46

ADJUSTING TABLE ROLLERS

Your planer is supplied with two table rollers (A) Fig. 47, which aid in feeding the stock by reducing friction and turn as the stock is fed through the planer. It is not possible to give exact dimensions on the proper height setting of the table rollers because each type of wood behaves differently. As a general rule, however, when planing rough stock the table rollers should be set **HIGH** (0.003" to 0.005") above the table surface and when planing finish stock the table rollers should be set **LOW**, 0.001" above the table surface or level with the table surface.

The table rollers on your planer are set for average planing and are parallel to the table surface. If you desire to adjust the table rollers higher or lower, proceed as follows:

⚠ WARNING DISCONNECT MACHINE FROM POWER SOURCE.

Lay a straight edge (B) Fig. 48, across both rollers and with a feeler gage (C) underneath the straight edge as shown, adjust height of table rollers by loosening set screws (D) Fig. 47, and turn screws (E) to raise or lower table rollers (A). Table rollers must be adjusted on the opposite side of table in the same manner. The table rollers must always be set parallel to the table. **IMPORTANT: The adjustment screws (E) Fig. 47, on both sides of the planer are on eccentrics and care should be taken when adjusting to keep the rollers from leading the stock to one side or the other. This can be accomplished by turning screws (E) Fig. 47, clockwise to raise or lower the rollers and turning the two screws on the opposite end of the rollers counterclockwise or vice versa.**

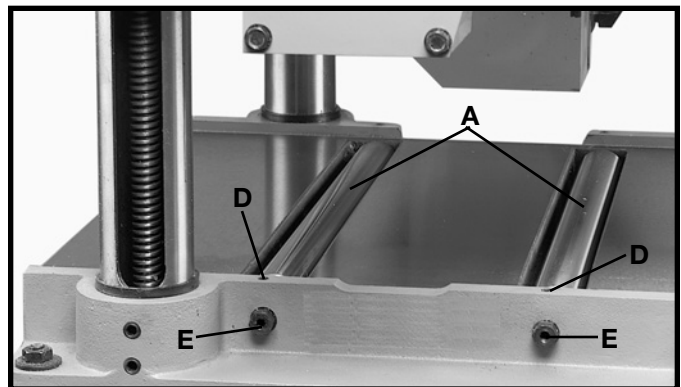

Fig. 47

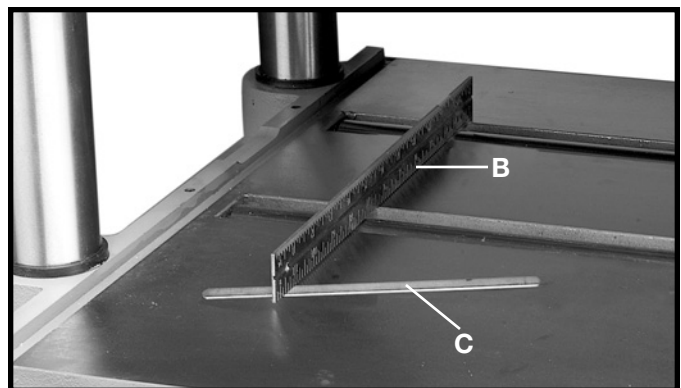

Fig. 48

ADJUSTING CUTTINGHEAD PARALLEL TO TABLE

The cuttinghead is set parallel to the table at the factory and no further adjustment should be necessary. If your machine is planing a taper, first check to see if the knives are set properly in the cutterhead. Then check to see if the cuttinghead is set parallel to the table as follows:

⚠ WARNING DISCONNECT MACHINE FROM POWER SOURCE.

1. Place gage block (A) Fig. 49, on table directly under front edge of head casting (B) as shown. Lower head casting until front edge of head casting (B) just touches the top of the gage block.

2. Move gage block (A) Fig. 50, to opposite end of table, as shown. Distance from table to edge of head casting should be the same.

3. Repeat **STEPS 2** and **3** on outfeed end of table.

4. If head casting is not parallel to table, tilt planer on its side as shown in Fig. 51. Remove bolt (C) and loosen bolt (D) Fig. 51, which will allow you to move the idler sprocket assembly (E) far enough to release tension on chain as shown in Fig. 52. Remove chain from sprocket on end of headcasting that must be adjusted. In this case chain has been removed from sprocket (F).

5. Turn sprocket (F) Fig. 52, by hand to bring that corner into adjustment with the other three corners. **IMPORTANT: THIS ADJUSTMENT IS VERY SENSITIVE AND IT SHOULD NOT BE NECESSARY TO TURN THE SPROCKET MORE THAN ONE OR TWO TEETH.** Turning sprocket (F) clockwise will decrease the distance between the table and headcasting. Counterclockwise will increase the distance.

6. Replace chain being careful not to disturb the position of the sprockets and replace idler sprocket assembly (E) Fig. 51.

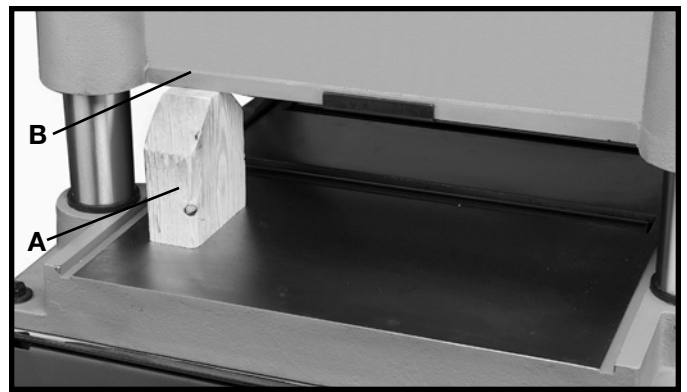

Fig. 49

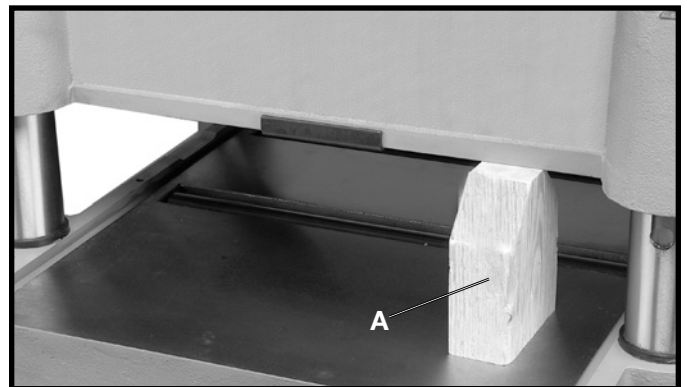

Fig. 50

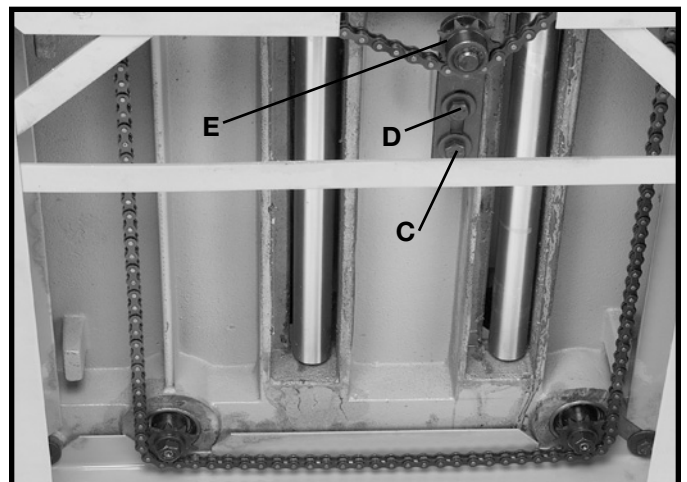

Fig. 51

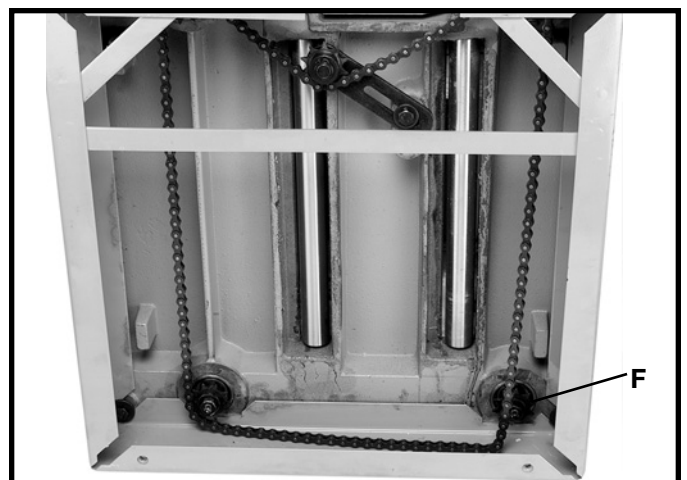

Fig. 52

MACHINE USE

When using your machine, you may want to follow these few simple steps for achieving the best results possible.

1. True Up One Face – Feed one face of the board over a jointer, making thin cuts with each pass, until the entire surface is flat.
2. Plane to Thickness – Place the side you just surfaced in **STEP 1** face down and feed the board through the planer, plane until this side is flat. Then plane both sides of the board until you are satisfied with the thickness, making thin cuts, alternating sides with each pass. If during the planing operation you notice the board twisting, warping or bowing, repeat **STEP 1** and true up one face.
3. When planing long stock, provide table extensions to support the infeed and outfeed end of the workpiece.
4. For best results, always engage cutterhead lock before planing, plane with the grain only, and keep planer table clean. Occasionally, wax table surface to reduce friction during the planing operation.
5. Cross-cut to Final Length – Cross-cut lumber to final length.

CAUTION THE KNIVES ON THE PLANER WILL NOT WEAR EVENLY BY FEEDING THE WOOD THROUGH THE SAME SPOT ON THE TABLE EVERY TIME. FEED THE WOOD THROUGH THE PLANER AT DIFFERENT SPOTS ON THE TABLE WHEN POSSIBLE, TO HELP ELIMINATE UNEVEN WEAR OF THE KNIVES.

TROUBLESHOOTING

For assistance with your machine, visit our website at www.deltamachinery.com for a list of service centers or call the DELTA Machinery help line at 1-800-223-7278 (In Canada call 1-800-463-3582).

MAINTENANCE



Fig. 53

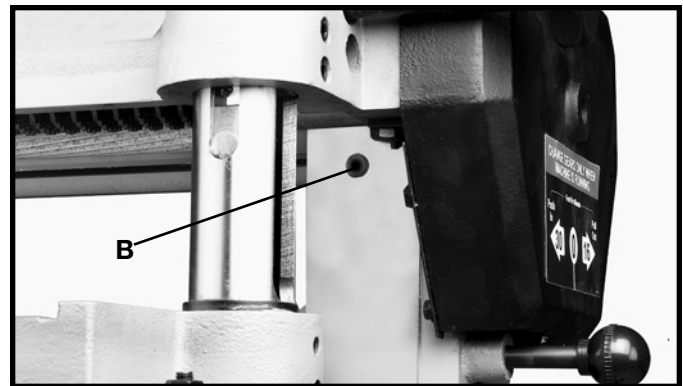

Fig. 54

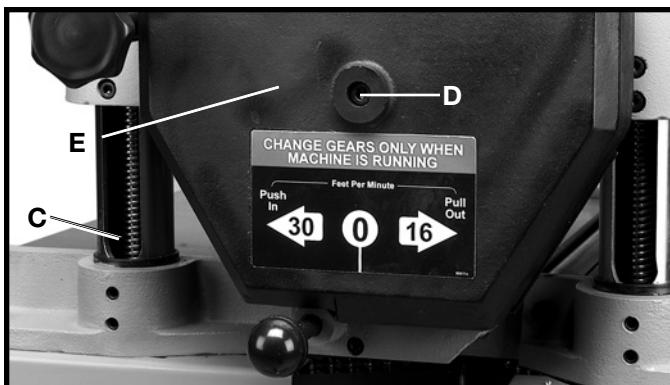

Fig. 55

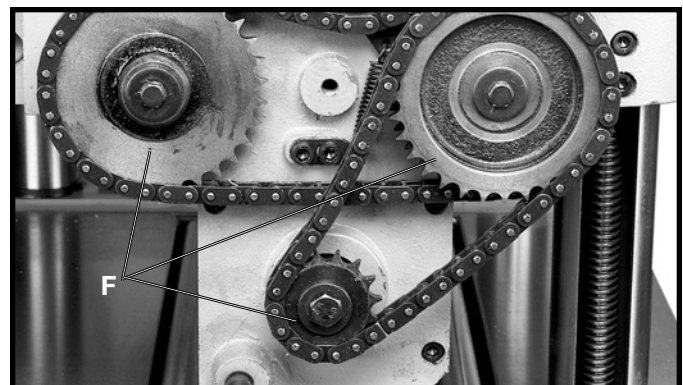

Fig. 56

LUBRICATION

The gear box oil should be changed once a year. Use extreme pressure gear oil, available from Delta in one pint cans (you will need approximately 20 oz.). The gear box drain plug is shown at (A) Fig. 53. The oil fill and level plug is shown at (B) Fig. 54.

The four raising screws, two of which are shown at (C)

Fig. 55, should be lubricated as required using a common grease.

Periodically remove screw (D) Fig. 55, and side cover (E). Thoroughly clean chains and sprockets (F) Fig. 56, and lubricate using a light machine oil. Replace side cover (E) Fig. 55, and secure with screw (D).

KEEP MACHINE CLEAN

Periodically blow out all air passages with dry compressed air. All plastic parts should be cleaned with a soft damp cloth. NEVER use solvents to clean plastic parts. They could possibly dissolve or otherwise damage the material.

▲WARNING Wear ANSI Z87.1 safety glasses while using compressed air.

FAILURE TO START

Should your machine fail to start, check to make sure the prongs on the cord plug are making good contact in the outlet. Also, check for blown fuses or open circuit breakers in the line.

TABLE LUBRICATION

Apply household floor paste wax to the machine table and extension table or other work surface weekly.

PROTECTING CAST IRON FROM RUST

To clean and protect cast iron tables from rust, you will need the following materials: 1 pushblock from a jointer, 1 sheet of medium Scotch-Brite™ Blending Hand Pad, 1 can of WD-40®, 1 can of degreaser, 1 can of TopCote® Aerosol. Apply the WD-40 and polish the table surface with the Scotch-Brite pad using the pushblock as a holddown. Degrease the table, then apply the TopCote® accordingly.

SERVICE



PARTS, SERVICE OR WARRANTY ASSISTANCE

All Delta Machines and accessories are manufactured to high quality standards and are serviced by a network of Porter-Cable • Delta Factory Service Centers and Delta Authorized Service Stations. To obtain additional information regarding your Delta quality product or to obtain parts, service, warranty assistance, or the location of the nearest service outlet, please call 1-800-223-7278 (In Canada call 1-800-463-3582).

ACCESSORIES

A complete line of accessories is available from your Delta Supplier, Porter-Cable • Delta Factory Service Centers, and Delta Authorized Service Stations. Please visit our Web Site www.deltamachinery.com for a catalog or for the name of your nearest supplier.

▲WARNING Since accessories other than those offered by Delta have not been tested with this product, use of such accessories could be hazardous. For safest operation, only Delta recommended accessories should be used with this product.

WARRANTY



Two Year Limited New Product Warranty

Delta will repair or replace, at its expense and at its option, any new Delta machine, machine part, or machine accessory which in normal use has proven to be defective in workmanship or material, provided that the customer returns the product prepaid to a Delta factory service center or authorized service station with proof of purchase of the product within two years and provides Delta with reasonable opportunity to verify the alleged defect by inspection. For all refurbished Delta product, the warranty period is 180 days. Delta may require that electric motors be returned prepaid to a motor manufacturer's authorized station for inspection and repair or replacement. Delta will not be responsible for any asserted defect which has resulted from normal wear, misuse, abuse or repair or alteration made or specifically authorized by anyone other than an authorized Delta service facility or representative. Under no circumstances will Delta be liable for incidental or consequential damages resulting from defective products. This warranty is Delta's sole warranty and sets forth the customer's exclusive remedy, with respect to defective products; all other warranties, express or implied, whether of merchantability, fitness for purpose, or otherwise, are expressly disclaimed by Delta.

PORTER-CABLE • DELTA SERVICE CENTERS (CENTROS DE SERVICIO DE PORTER-CABLE • DELTA)

Parts and Repair Service for Porter-Cable • Delta Machinery are Available at These Locations
(Obtenga Refaccion de Partes o Servicio para su Herramienta en los Siguietes Centros de Porter-Cable • Delta)

ARIZONA

Phoenix 85013-2906
4501 N. 7th Ave.
Phone: (602) 279-6414
Fax: (602) 279-5470

CALIFORNIA

Ontario 91761 (Los Angeles)
3949A East Guasti Road
Phone: (909) 390-5555
Fax: (909) 390-5554

San Diego 92111
7290 Clairemont Mesa Blvd.
Phone: (858) 279-2011
Fax: (858) 279-0362

San Leandro 94577 (Oakland)
3039 Teagarden Street
Phone: (510) 357-9762
Fax: (510) 357-7939

COLORADO

Denver 80223
700 West Mississippi Ave.
Phone: (303) 922-8325
Fax: (303) 922-0245

FLORIDA

Davie 33314 (Miami)
4343 South State Rd. 7 (441)
Unit #107
Phone: (954) 321-6635
Fax: (954) 321-6638

Tampa 33634
4909 West Waters Ave.
Phone: (813) 884-0434
Fax: (813) 888-5997

GEORGIA

Forest Park 30297 (Atlanta)
5442 Frontage Road,
Suite 112
Phone: (404) 608-0006
Fax: (404) 608-1123

ILLINOIS

Addison 60101 (Chicago)
400 South Rohlwing Rd.
Phone: (630) 424-8805
Fax: (630) 424-8895

KANSAS

Overland Park 66214
9201 Quivira Road
Phone: (913) 495-4330
Fax: (913) 495-4378

MARYLAND

Elkridge 21075 (Baltimore)
7397-102 Washington Blvd.
Phone: (410) 799-9394
Fax: (410) 799-9398

MASSACHUSETTS

Franklin 02038 (Boston)
Franklin Industrial Park
101E Constitution Blvd.
Phone: (508) 520-8802
Fax: (508) 528-8089

MICHIGAN

Madison Heights 48071 (Detroit)
30475 Stephenson Highway
Phone: (248) 597-5000
Fax: (248) 597-5004

MINNESOTA

Eden Prairie 55344
9709 Valley View Road
Phone: (952) 884-9191
Fax: (952) 884-3750

MISSOURI

St. Louis 63146
11477 Page Service Drive
Phone: (314) 997-9100
Fax: (314) 997-9183

NEW YORK

Flushing 11365-1595 (N.Y.C.)
175-25 Horace Harding Expwy.
Phone: (718) 225-2040
Fax: (718) 423-9619

NORTH CAROLINA

Charlotte 28270
9129 Monroe Road, Suite 115
Phone: (704) 841-1176
Fax: (704) 708-4625

OHIO

Columbus 43229
1948 Schrock Road
Phone: (614) 895-3112
Fax: (614) 895-3187

Parma Heights OH 44130
6485 Pearl Road
Phone: (440) 842-9100
Fax: (440) 884-3430

OREGON

Portland 97230
14811 North East Airport Way
Phone: (503) 255-6556
Fax: (503) 255-6543

PENNSYLVANIA

Willow Grove 19090
(Philadelphia)
520 North York Road
Phone: (215) 658-1430
Fax: (215) 658-1433

TEXAS

Carrollton 75006 (Dallas)
1300 Interstate 35 N, Suite 112
Phone: (972) 446-2996
Fax: (972) 446-8157

Houston 77022-2122
536 East Tidwell Rd.
Phone: (713) 692-7111
Fax: (713) 692-1107

WASHINGTON

Auburn 98001(Seattle)
3320 West Valley HWY, North
Building D, Suite 111
Phone: (253) 333-8353
Fax: (253) 333-9613

Authorized Service Stations are located in many large cities. Telephone **800-438-2486** or **731-541-6042** for assistance locating one. Parts and accessories for Porter-Cable-Delta products should be obtained by contacting any Porter-Cable-Delta Distributor, Authorized Service Center, or Porter-Cable-Delta Factory Service Center. If you do not have access to any of these, call **800-223-7278** and you will be directed to the nearest Porter-Cable-Delta Factory Service Center. Las Estaciones de Servicio Autorizadas están ubicadas en muchas grandes ciudades. Llame al **800-438-2486** ó al **731-541-6042** para obtener asistencia a fin de localizar una. Las piezas y los accesorios para los productos Porter-Cable-Delta deben obtenerse poniéndose en contacto con cualquier distribuidor Porter-Cable-Delta, Centro de Servicio Autorizado o Centro de Servicio de Fábrica Porter-Cable-Delta. Si no tiene acceso a ninguna de estas opciones, llame al **800-223-7278** y le dirigirán al Centro de Servicio de Fábrica Porter-Cable-Delta más cercano.

CANADIAN PORTER-CABLE • DELTA SERVICE CENTERS

ALBERTA

Bay 6, 2520-23rd St. N.E.
Calgary, Alberta
T2E 8L2
Phone: (403) 735-6166
Fax: (403) 735-6144

BRITISH COLUMBIA

8520 Baxter Place
Burnaby, B.C.
V5A 4T8
Phone: (604) 420-0102
Fax: (604) 420-3522

MANITOBA

1699 Dublin Avenue
Winnipeg, Manitoba
R3H 0H2
Phone: (204) 633-9259
Fax: (204) 632-1976

ONTARIO

505 Southgate Drive
Guelph, Ontario
N1H 6M7
Phone: (519) 767-4132
Fax: (519) 767-4131

QUÉBEC

1515 ave.
St-Jean Baptiste, Suite 160
Québec, Québec
G2E 5E2
Phone: (418) 877-7112
Fax: (418) 877-7123

1447, Begin
St-Laurent, (Montréal),
Québec
H4R 1V8
Phone: (514) 336-8772
Fax: (514) 336-3505

The following are trademarks of PORTER-CABLE • DELTA (Las siguientes son marcas registradas de PORTER-CABLE • DELTA S.A.) (Les marques suivantes sont des marques de fabricant de la PORTER-CABLE • DELTA): Auto-Set®, BAMMER®, B.O.S.S.®, Builder's Saw®, Contractor's Saw®, Contractor's Saw II™, Delta®, DELTACRAFT®, DELTAGRAM™, Delta Series 2000™, DURATRONIC™, Emc2™, FLEX®, Flying Chips™, FRAME SAW®, Grip Vac™, Homecraft®, INNOVATION THAT WORKS®, Jet-Lock®, JETSTREAM®, 'kickstand®, LASERLOC®, MICRO-SET®, Micro-Set®, MIDI LATHE®, MORTEN™, NETWORK™, OMNIJIG®, POCKET CUTTER®, PORTA-BAND®, PORTA-PLANE®, PORTER-CABLE®&(design), PORTER-CABLE®PROFESSIONAL POWER TOOLS, PORTER-CABLE REDEFINING PERFORMANCE™, Posi-Matic®, Q-3®&(design), QUICKSAND®&(design), QUICKSET™, QUICKSET II®, QUICKSET PLUS™, RIPTIDE™&(design), SAFE GUARD II®, SAFE-LOC®, Sanding Center®, SANDTRAP®&(design), SAW BOSS®, Sawbuck™, Sidekick®, SPEED-BLOC®, SPEEDMATIC®, SPEEDTRONIC®, STAIR EASE®, The American Woodshop®&(design), The Lumber Company®&(design), THE PROFESSIONAL EDGE®, THE PROFESSIONAL SELECT®, THIN-LINE™, TIGER®, TIGER CUB®, TIGER SAW®, TORQBUSTER®, TORQ-BUSTER®, TRU-MATCH™, TWIN-LITE®, UNIGUARD®, Unifence®, UNIFEEDER™, Unihead®, Uniplane™, Unirip®, Unisaw®, Univise®, Versa-Feeder®, VERSA-PLANE®, WHISPER SERIES®, WOODWORKER'S CHOICE™.

Trademarks noted with ™ and ® are registered in the United States Patent and Trademark Office and may also be registered in other countries. Marcas Registradas con el signo de ™ y ® son registradas por la Oficina de Registros y Patentes de los Estados Unidos y también pueden estar registradas en otros países.