

# Microwave Oven

## Owner's Instructions & Cooking Guide

imagine the possibilities

Thank you for purchasing this Samsung product.  
Please register your product at

[www.samsung.com/register](http://www.samsung.com/register)



**RoHS compliant**

Our product complies with "The Restriction Of the use of certain Hazardous Substances in electrical and electronic equipment", and we do not use the 6 hazardous materials-Cadmium (Cd), Lead (Pb), Mercury (Hg), Hexavalent Chromium (Cr +6), Poly Brominated biphenyls (PBBs), Poly Brominated Diphenyl Ethers(PBDEs)- in our products.

Planet First 100% Recycled Paper

This manual is made with 100% recycled paper.

**SAMSUNG**

## CONTENTS

Quick look-up guide .....	2
Accessories .....	3
Oven .....	4
Control panel .....	4
Using this instruction booklet .....	5
Safety information .....	5
Installing your microwave oven .....	12
Setting the time .....	13
How a microwave oven works .....	13
Checking that your oven is operating correctly .....	14
What to do if you are in doubt or have a problem .....	14
Cooking/reheating .....	15
Power levels .....	15
Stopping the cooking .....	16
Adjusting the cooking time .....	16
Using the instant reheat/cook feature .....	16
Instant reheat/cook settings .....	17
Using the auto rapid defrost feature .....	18
Auto rapid defrost settings .....	18
Choosing the accessories .....	19
Grilling .....	19
Combining microwaves and the grill .....	20
Switching the beeper off .....	20
Safety-locking your microwave oven .....	20
Multistage cooking .....	21
Cookware guide .....	22
Cooking guide .....	23
Cleaning your microwave oven .....	33
Storing and repairing your microwave oven .....	33
Technical specifications .....	34

## QUICK LOOK-UP GUIDE

If you want to cook some food.

1. Place the food in the oven.  
Select the power level by pressing the **Power Level** (☰) button once or more times.



2. Select the cooking time by pressing the **10 min**, **1 min** or **10 s** button as required.

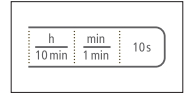

3. Press the **Start** (◊) button.

**Result :** Cooking starts.  
The oven beeps four times when cooking is over.



If you want to defrost some food.

1. Place the frozen food in the oven.  
Press the **Rapid** (☼☼) button once or more times according to the type of food to be defrosted.



2. Select the weight by pressing the **kg** and **g** buttons as required.



3. Press the **Start** (◊) button.



If you want to add an extra minute.

Leave the food in the oven.  
Press **+30** once or more times for each extra 30 seconds that you wish to add.



If you want to grill some food.

1. Preheat the grill to the required temperature, by pressing the **Grill** (U) button, time setting (**10 min, 1 min** and **10 s**) and **Start** (◇) button.

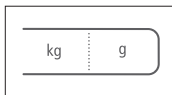

2. Place the food on the rack in the oven. Press the **Grill** (U) button. Select the cooking time by pressing the **10 min, 1 min** and **10 s** buttons.

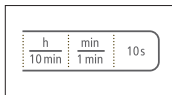

3. Press the **Start** (◇) button.

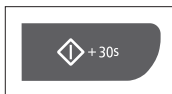

## ACCESSORIES

Depending on the model that you have purchased, you are supplied with several accessories that can be used in a variety of ways.

1. **Coupler**, already placed over the motor shaft in the base of the oven.

**Purpose :** The coupler rotates the turntable.

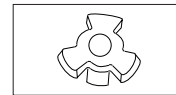

2. **Roller ring**, to be placed in the centre of the oven.

**Purpose :** The roller ring supports the turntable.

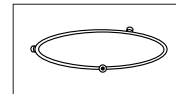

3. **Turntable**, to be placed on the roller ring with the centre fitting to the coupler.

**Purpose :** The turntable serves as the main cooking surface; it can be easily removed for cleaning.

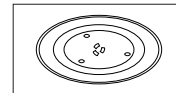

4. **Metal rack**, to be placed on the turntable.

**Purpose :** The metal rack can be used in grill and combination cooking.

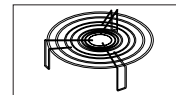

-  **DO NOT** operate the microwave oven without the roller ring and turntable.

## OVEN

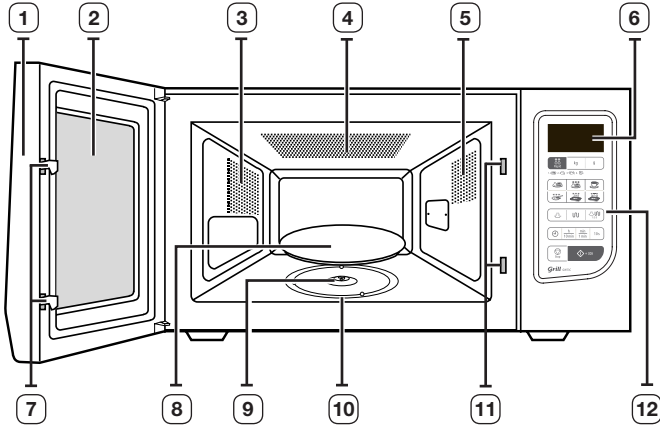

- |                      |                            |
|----------------------|----------------------------|
| 1. DOOR HANDLE       | 7. DOOR LATCHES            |
| 2. DOOR              | 8. TURNTABLE               |
| 3. VENTILATION HOLES | 9. COUPLER                 |
| 4. GRILL             | 10. ROLLER RING            |
| 5. LIGHT             | 11. SAFETY INTERLOCK HOLES |
| 6. DISPLA            | 12. CONTROL PANEL          |

## CONTROL PANEL

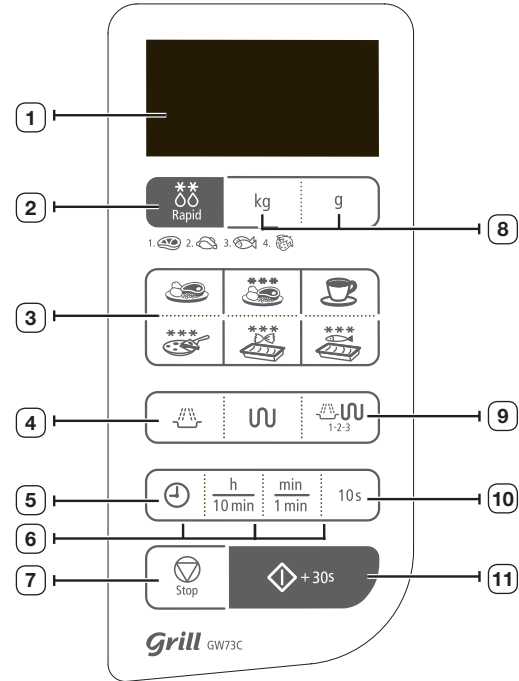

- |  |                         |
|--|-------------------------|
| 1. DISPLAY                                 | 6. TIME SETTING         |
| 2. AUTO RAPID DEFROST<br>FEATURE SELECTION | 7. STOP/CANCEL BUTTON   |
| 3. INSTANT REHEAT/COOK<br>SELECTION        | 8. WEIGHT SELECTION     |
| 4. GRILL MODE SELECTION                    | 9. COMBI MODE SELECTION |
| 5. MICROWAVE MODE<br>SELECTION             | 10. CLOCK SETTING       |
|  | 11. START BUTTON        |

## USING THIS INSTRUCTION BOOKLET

You have just purchased a SAMSUNG microwave oven. Your Owner's Instructions contain much valuable information on cooking with your microwave oven:

- Safety precautions
- Suitable accessories and cookware
- Useful cooking tips

Inside the cover you will find a quick look-up guide explaining four basic cooking operations:

- Cooking food
- Auto Power Defrosting of food
- Grilling food
- Adding extra cooking time













At the front of the booklet you will find illustrations of the oven, and more importantly the control panel, so that you can find the buttons more easily.

## SAFETY INFORMATION

- Before operating the appliance, please read this manual thoroughly and retain it at a safe place near the appliance for your future reference.
- Use this appliance only for its intended purpose as described in this instruction manual. This appliance is not intended for use by persons (including children) with reduced physical, sensory or mental capabilities, or lack of experience and knowledge, unless they have been given supervision or instruction concerning use of the appliance by a person responsible for their safety. Warnings and Important Safety Instructions in this manual do not cover all possible conditions and situations that may occur. It is your responsibility to use common sense, caution, and care when installing, maintaining, and operating your appliance.
- Because these following operating instructions cover various models, the characteristics of your microwave oven may differ slightly from those described in this manual and not all warning signs may be applicable. If you have any questions or concerns, contact your nearest service center or find help and information online at [www.samsung.com](http://www.samsung.com).

Important safety symbols and precautions.

The following symbols are used in the text of this Owner's Manual:

 <b>WARNING</b>	Hazards or unsafe practices that may result in <b>severe personal injury or death</b> .
 <b>CAUTION</b>	Hazards or unsafe practices that may result in <b>minor personal injury or property damage</b> .
 <b>CAUTION</b>	To reduce the risk of fire, explosion, electric shock, or personal injury when using your microwave oven, follow these basic safety precaution
	Do NOT attempt.
	Do NOT disassemble.
	Do NOT touch.
	Follow directions explicitly.
	Unplug the power plug from the wall socket.
	Make sure the machine is grounded to prevent electric shock.
	Call the service center for help.
	Note
	Important

## Severe warning signs for installation

---

-  The installation of this appliance must be performed by a qualified microwave service technician trained by the manufacturer. Please see the section "Installing your Microwave Oven".

Plug the power cord into the proper wall socket or higher and use the socket for this appliance only. Plug the power plug into the wall socket firmly. In addition, do not use an extension cord.

- Failure to do so and sharing a wall socket with other appliances using a power strip or extending the power cord may result in electric shock or fire.
- Do not use an electric transformer. It may result in electric shock or fire.

The installation of this appliance must be performed by a qualified technician or service company.

- Failing to do so may result in electric shock, fire, an explosion, problems with the product, or injury.

The microwave oven is intended to be used on the counter or counter top use only, the microwave oven shall not be placed in a cabinet.

---

-  Do not install this appliance near a heater, inflammable material. Do not install this appliance in a humid, oily or dusty location, in a location exposed to direct sunlight and water (rain drops). Do not install this appliance in a location where gas may leak.

- This may result in electric shock or fire.

The appliance is not intended for installing in road vehicles, caravans and similar vehicles etc.

-  This appliance must be properly grounded. Do not ground the appliance to a gas pipe, plastic water pipe, or telephone line.

- This may result in electric shock, fire, an explosion, or problems with the product.
- Never plug the power cord into a socket that is not grounded correctly and make sure that it is in accordance with local and national codes.

## Caution signs for installation

---

-  This appliance should be positioned in such a way that it is accessible to the power plug.

- Failure to do so may result in electric shock or fire due to electric leakage.

Install your appliance on a level and hard floor that can support its weight.

- Failure to do so may result in abnormal vibrations, noise, or problems with the product.

Install the appliance while maintaining the proper distance from the wall.

- Failure to do so may result in fire due to overheating.

The minimum height of free space necessary above the top surface of the oven.

## Severe warning signs for electric

---

-  Remove all foreign substances such as dust or water from the power plug terminals and contact points using a dry cloth on a regular basis.

- Unplug the power plug and clean it with a dry cloth.
- Failure to do so may result in electric shock or fire.

Plug the power plug into the wall socket in the right direction so that the cord runs towards the floor.

- If you plug the power plug into the socket in the opposite direction, the electric wires within the cable may be damaged and this may result in electric shock or fire.

 Plug the power plug into the wall socket firmly. Do not use a damaged power plug, damaged power cord or loose wall socket.

- This may result in electric shock or fire.

Do not pull or excessively bend the power cord.

Do not twist or tie the power cord.

Do not hook the power cord over a metal object, place a heavy object on the power cord, insert the power cord between objects, or push the power cord into the space behind the appliance.

- This may result in electric shock or fire.

Do not pull the power cord, when unplugging the power plug.

- Unplug the power plug by holding the plug.
- Failure to do so may result in electric shock or fire.

---

 When the appliance or the cord is damaged, contact your nearest service centre.

### Caution signs for electric

---

 Unplug the power plug when the appliance is not being used for long periods of time or during a thunder/lightning storm.

- Failure to do so may result in electric shock or fire.

### Severe warning signs for using

---

 In the event of a gas leak (such as propane gas, LP gas, etc.), ventilate immediately without touching the power plug. Do not touch the appliance or power cord.

- Do not use a ventilating fan.
- A spark may result in an explosion or fire.

Take care that the door, heater or any of the other parts do not come into contact with the body while cooking or just after cooking.

- Failure to do so may result in burns.

During use the appliance becomes hot. Care should be taken to avoid touching heating elements inside the oven.

When moving heating elements, make sure to use the equipment designed to move heating element while wearing safety gloves provided with the product, and see if temperature drops sufficiently (at least 10 minutes after grill or combination cooking operation) after operation.

ALWAYS use oven gloves when removing a dish from the oven to avoid unintentional burn.

Stand at arms length from the oven when opening the door.

**Reason :** The hot air or steam released may cause scalding.

Microwave heating of beverages can result in delayed eruptive boiling, therefore care must be taken when handling the container; To prevent this situation ALWAYS allow a standing time of at least 20 seconds after the oven has been switched off so that the temperature can equalize. Stir during heating, if necessary, and ALWAYS stir after heating. In the event of scalding, follow these FIRST AID instructions:

- Immerse the scalded area in cold water for at least 10 minutes.
- Cover with a clean, dry dressing.
- Do not apply any creams, oils or lotions.
- Contact a doctor

If the supply cord is damaged, it must be replaced by the manufacturer, its service agent or similarly qualified persons in order to avoid a hazard.

Children should be supervised to ensure that they do not play with the appliance.

Eggs in their shell and whole hard-boiled eggs should not be heated in microwave ovens since they may explode even after microwave heating has ended.

★ **WARNING :** The contents of feeding bottles and baby food jars shall be stirred or shaken and the temperature checked before consumption, in order to avoid burns.

**WARNING :** Only allow children to use the oven without supervision when adequate instructions have been given so that the child is able to use the oven in a safe way and understands the hazards of improper use.

**WARNING :** When the appliance is operated in the combination mode, children should only use the oven under adult supervision due to the temperatures generated.

The appliance is not intended for use by persons (including children) with reduced physical, sensory or mental capabilities, or lack of experience and knowledge, unless they have been given supervision or instruction concerning use of the appliance by a person responsible for their safety.

**WARNING :** Accessible parts may become hot during use. Young children should be kept away.

☐ Do not touch the power plug with wet hands.

- This may result in electric shock.

Do not turn the appliance off by unplugging the power plug while an operation is in progress.

- Plugging the power plug into the wall socket again may cause a spark and result in electric shock or fire.

Keep all packaging materials well out of the reach of children, as packaging materials can be dangerous to children.

- If a child places a bag over its head, it may result in suffocation.

This appliance is not intended for use by persons (including children) with reduced physical, sensory or mental capabilities, or lack of experience and knowledge, unless they have been given supervision or instruction concerning use of the appliance by a person responsible for their safety.

- Failing to do so may result in electric shock, burns or injury.

Never use this appliance for purposes other than cooking.

- Failure to do so may result in fire.

Open sealed containers (baby bottles, milk bottles, etc.) and make a hole in food items such as shells or nuts (eggs, chestnuts, etc) with a knife, before cooking them.

- Failure to do so may result in burns or injury due to the item bursting.

Do not touch the inside of the appliance immediately after cooking, because the inside of the appliance is hot after being heated for a long time or heating a small amount of food.

- Failure to do so may result in burns.

Do not use aluminium foil, metal objects (such as containers, forks, etc.) or containers with golden or silver trims.

- This may result in sparks or fire.

Never heat plastic or paper containers and do not use them with the oven function.

- Failure to do so may result in fire.

Take care that food does not come into contact with the heater when cooking food with the oven.

- This may result in fire.

Do not over-heat food.

- This may result in fire.

Do not use or place inflammable sprays or objects near the oven.

- This may result in fire or an explosion.



-  Do not open the door when the food in the cooking compartment is burning.
- If you open the door, an inflow of oxygen occurs and this may result in fire.
- NEVER fill the container to the top and choose a container that is wider at the top than at the bottom to prevent the liquid from boiling over. Bottles with narrow necks may also explode if overheated.

NEVER heat a baby's bottle with the teat on, as the bottle may explode if overheated.

DO NOT touch heating elements or interior oven walls until the oven has cooled down.

Do not immerse the power cable or plug in water and keep the power cable away from heated surfaces.

Do not operate this appliance if it has a damaged power cable or plug.

DO NOT operate the microwave oven when it is empty. The power will be cut off automatically for safety. You can operate normally after letting it stand for over 30 minutes. It is best to leave a glass of water inside the oven at all times. The water will absorb the microwave energy if the oven accidentally started.

**WARNING :** If the door or door seals are damaged, the oven must not be operated until it has been repaired by a competent person.

**WARNING :** Liquids and other foods must not be heated in sealed containers since they are liable to explode.

-  If the appliance is flooded cut the power immediately and please contact your nearest service centre.
- Failure to do so may result in electric shock or fire.
- If the appliance generates a strange noise, a burning smell or smoke, unplug the power plug immediately and contact your nearest service centre.
- Failure to do so may result in electric shock or fire.

-  Do not attempt to repair, disassemble, or modify the appliance yourself.
- Since a high voltage current enters the product chassis, it may result in electric shock or fire.
  - You may be exposed to electromagnetic waves.
  - When repairing the appliance is required, contact your nearest service centre.

**WARNING :** It is hazardous for anyone other than a competent person to carry out any service or repair operation that involves the removal of a cover which gives protection against exposure to microwave energy.

-  If any foreign substance such as water has entered the appliance, unplug the power plug and contact your nearest service centre.

- Failure to do so may result in electric shock or fire.

If smoke is observed, switch off or unplug the appliance and keep the door closed in order to stifle any flames;

### Caution signs for using

-  Only use utensils that are suitable for use in microwave ovens; DO NOT use any metallic containers, Dinnerware with gold or silver trimmings, Skewers, forks, etc. Remove wire twist ties from paper or plastic bags.
- Reason :** Electric arcing or sparking may occur and may damage the oven.

When heating food in plastic or paper containers, keep an eye on the oven due to the possibility of ignition;

Small amounts of food require shorter cooking or heating time. If normal times are allowed they may overheat and burn.

You may notice a Clicking sound during operation (especially when the oven is defrosting).

**Reason :** This sound is normal when the electrical power output is changing.

- ★ Young children should NEVER be allowed to use or play with the microwave oven. Nor should they be left unattended near the microwave oven when it is in use. Items of interest to children should not be stored or hidden just above the oven.

Children should be supervised to ensure that they do not play with the appliance.

- ☒ Take care as beverages or food may be very hot after heating.
  - Especially when feeding a child, check that it has cooled sufficiently.
 Take care when heating liquids such as water or other beverages.
  - Make sure to stir during or after cooking.
  - Avoid using a slippery container with a narrow neck.
  - Remove the container at least 30 seconds after heating.
  - Failing to do so may result in an abrupt overflow of the contents and cause burns.

Do not hold food or any part there of during or immediately after cooking.

- Use cooking gloves because it may be very hot and you could burn yourself.
- If you pull the ceramic dish or well-being multi-purpose pan forwards, food may spill and this may result in burns.

When the surface is cracked, turn the power switch of the appliance off.

- Failure to do so may result in electric shock.

Do not scratch the glass of the oven door with a sharp object.

- This may result in the glass being damaged or broken.

Do not stand on top of the appliance or place objects (such as laundry, oven cover, lighted candles, lighted cigarettes, dishes, chemicals, metal objects, etc.) on the appliance.

- Items, such as a cloth, may be caught in the door.
- This may result in electric shock, fire, problems with the product, or injury.

Do not operate the appliance with wet hands.

- This may result in electric shock.

Do not spray volatile material such as insecticide onto the surface of the appliance.

- As well as being harmful to humans, it may also result in electric shock, fire or problems with the product.

Do not apply excessive pressure or impact to the door or to the inside of the appliance.

- This may result in deformation to the product or injury due to electric wave leakage.
- Hanging onto the door may result in the product falling and causing injury.
- If the door is damaged, do not use the appliance and contact your nearest service centre.

Do not place the appliance over a fragile object such as a sink or glass object.

- This may result in damage to the sink or glass object.

Use the appliance only after closing the door.

- If you use the appliance when it is contaminated by foreign substances such as food waste, it may result in problems with the appliance.

Take care when removing the wrapping from food that has just been taken out of the appliance.

- If the food is hot, hot steam may be emitted abruptly when removing the wrapping and you may burn yourself.

Do not unplug the appliance by pulling at the power cord, always grip plug firmly and pull straight out from the outlet.

- Damage to the cord may cause short-circuit, fire and/or electric shock.

- ☒ Do not put your face or body close to the appliance while cooking or when opening the door just after cooking.

- Take care that children do not come close to the appliance.
- Failure to do so may result in burns from the heat.

Do not place food or heavy objects over the door when opening the door.

- The food or object may fall and this may result in burns or injury.

Do not abruptly cool the door, the inside of the appliance, or the dish by pouring water over it during or just after cooking.

- This may result in damage to the appliance. The steam or water spray may result in burns or injury.

Appliances are not intended to be operated by means of an external timer or separate remote-control system.

### ⚠ Severe warning signs for cleaning

---

- ☒ Do not clean the appliance by spraying water directly onto it. Do not use benzene, thinner or alcohol to clean the appliance.
- This may result in discoloration, deformation, damage, electric shock or fire.

Before cleaning or performing maintenance, unplug the appliance from the wall socket and remove food waste from the door and cooking compartment.

- Failure to do so may result in electric shock or fire.

Do not use harsh abrasive cleaners or sharp metal scrapers to clean the oven door glass since they can scratch the surface, which may result in shattering of the glass.

Do not use your microwave oven to dry papers or clothes.

For your safety, do not use high-pressure water cleaners or steam jet cleaners.

### ⚠ Caution signs for cleaning

---

- ★ The oven should be cleaned regularly and any food deposits removed.

Failure to maintain the oven in a clean condition could lead to deterioration of the surface that could adversely affect the life of the appliance and possibly result in a hazardous situation.

- ☒ Take care not to hurt yourself when cleaning the appliance (external/internal).

- You may hurt yourself on the sharp edges of the appliance.

## PRECAUTIONS TO AVOID POSSIBLE EXPOSURE TO EXCESSIVE MICROWAVE ENERGY

Failure to observe the following safety precautions may result in harmful exposure to microwave energy.

- (a) Under no circumstances should any attempt be made to operate the oven with the door open or to tamper with the safety interlocks (door latches) or to insert anything into the safety interlock holes.
- (b) Do not place any object between the oven door and front face or allow food or cleaner residues to accumulate on sealing surfaces. Ensure that the door and door sealing surfaces are kept clean by wiping after use first with a damp cloth and then with a soft dry cloth.
- (c) Do not operate the oven if it is damaged until it has been repaired by a qualified microwave service technician trained by the manufacturer. It is particularly important that the oven door closes properly and that there is no damage to the:
  - (1) Door (bent)
  - (2) Door hinges (broken or loose)
  - (3) door seals and sealing surfaces
- (d) The oven should not be adjusted or repaired by anyone other than a properly qualified microwave service technician trained by the manufacturer.

This product is a Group 2 Class B ISM equipment. The definition of group 2 which contains all ISM equipment in which radio-frequency energy is intentionally generated and/or used in the form of electromagnetic radiation for the treatment of material, and EDM and arc welding equipment. For Class B equipment is equipment suitable for use in domestic establishments and in establishments directly connected to a low voltage power supply network which supplies buildings used for domestic purposes.

## INSTALLING YOUR MICROWAVE OVEN

Place the oven on a flat level surface 85 cm above the floor. The surface should be strong enough to safely bear the weight of the oven.

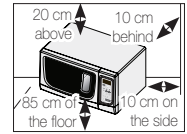

1. When you install your oven, make sure there is adequate ventilation for your oven by leaving at least 10 cm (4 inches) of space behind and, on the sides of the oven and 20 cm (8 inches) of space above.

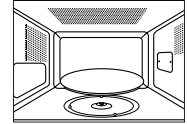

2. Remove all packing materials inside the oven. Install the roller ring and turntable. Check that the turntable rotates freely.



3. This microwave oven has to be positioned so that plug is accessible.

-  If the supply cord is damaged, it must be replaced by a special cord or assembly available from the manufacturer or its service agent. For your personal safety, plug the cable into a 3-pin, 230 Volt, 50 Hz, AC earthed socket. If the power cable of this appliance is damaged, it must be replaced by a special cable.
-  Do not install the microwave oven in hot or damp surroundings like next to a traditional oven or radiator. The power supply specifications of the oven must be respected and any extension cable used must be of the same standard as the power cable supplied with the oven. Wipe the interior and the door seal with a damp cloth before using your microwave oven for the first time.

## SETTING THE TIME

Your microwave oven has an inbuilt clock. When power is supplied, “:0”, “88:88” or “12:00” is automatically displayed on the display.

Please set the current time. The time can be displayed in either the 12-hour or 24-hour notation. You must set the clock:

- When you first install your microwave oven
- After a power failure

 Do not forget to reset the clock when you switch to and from summer and winter time.

1. To display the time in the... Then press the **Clock** (🕒) button...

24-hour notation  
12-hour notation

Once  
Twice



2. Set the hour with the h button and the minutes with the min button.

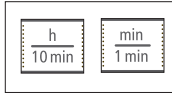

3. When the right time is displayed, press the **Clock** (🕒) button again to start the clock.

**Result :** The time is displayed whenever you are not using the microwave oven.



## HOW A MICROWAVE OVEN WORKS

Microwaves are high-frequency electromagnetic waves; the energy released enables food to be cooked or reheated without changing either the form or the colour.

You can use your microwave oven to:

- Defrost
- Instant Reheat/Cook
- Cook

Cooking Principle.

1. The microwaves generated by the magnetron are distributed uniformly as the food rotates on the turntable. The food is thus cooked evenly.

2. The microwaves are absorbed by the food up to a depth of about 1 inch (2.5 cm). Cooking then continues as the heat is dissipated within the food.

3. Cooking times vary according to the recipient used and the properties of the food:

- Quantity and density
- Water content
- Initial temperature (refrigerated or not)

 As the centre of the food is cooked by heat dissipation, cooking continues even when you have taken the food out of the oven. Standing times specified in recipes and in this booklet must therefore be respected to ensure:

- Even cooking of the food right to the centre
- The same temperature throughout the food

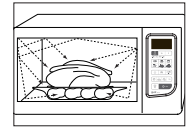

## CHECKING THAT YOUR OVEN IS OPERATING CORRECTLY

The following simple procedure enables you to check that your oven is working correctly at all times. Open the oven door by pushing the large button in the bottom right-hand corner of the control panel.

First, place a bowl of water on the turntable. Then, close the door.

1. Press the **Power Level** (☰) button and set the time to 4-5 minutes by pressing the **1 min** button the appropriate number of times.

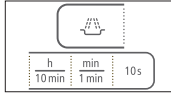

2. Press the **Start** (◊) button.

**Result :** The oven heats the water for 4 to 5 minutes. The water should then be boiling.



-  The oven must be plugged into an appropriate wall socket. The turntable must be in position in the oven. If a power level other than the maximum is used, the water takes longer to boil.

## WHAT TO DO IF YOU ARE IN DOUBT OR HAVE A PROBLEM

If you have any of the problems listed below try the solutions given.

### This is normal.

- Condensation inside the oven.
- Air flow around the door and outer casing.
- Light reflection around the door and outer casing.
- Steam escaping from around the door or vents.

### The oven does not start when you press the **Start** (◊) button.

- Is the door completely closed?

### The food is not cooked at all.

- Have you set the timer correctly and/or pressed the **Start** (◊) button?
- Is the door closed?
- Have you overloaded the electric circuit and caused a fuse to blow or a breaker to be triggered?

### The food is either overcooked or undercooked.

- Was the appropriate cooking length set for the type of food?
- Was an appropriate power level chosen?

### Sparking and cracking occur inside the oven (arcing).

- Have you used a dish with metal trimmings?
- Have you left a fork or other metal utensil inside the oven?
- Is aluminum foil too close to the inside walls?

### The oven causes interference with radios or televisions.

- Slight interference may be observed on televisions or radios when the oven is operating. This is normal. To solve this problem, install the oven away from televisions, radios and aerials.
- If interference is detected by the oven's microprocessor, the display may be reset. To solve this problem, disconnect the power plug and reconnect it. Reset the time.

-  If the above guidelines do not enable you to solve the problem, contact your local dealer or SAMSUNG after-sales service.

## COOKING/REHEATING

The following procedure explains how to cook or reheat food. ALWAYS check your cooking settings before leaving the oven unattended. First, place the food in the centre of the turntable. Then, close the door.

1. Press the **Power Level** (🔊) button.

**Result :** The 750 W (maximum cooking power) indications are displayed:  
Select the appropriate power level by pressing the **Power Level** (🔊) button again until the corresponding wattage is displayed. Refer to the power level table on the next page.



2. Set the cooking time by pressing the **10 min**, **1 min** and **10 s** button.

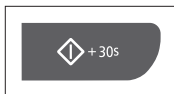

3. Press the **Start** (▶) button.

**Result :** The oven light comes on and the turntable starts rotating.

- 1) Cooking starts and when it has finished the oven beeps four times.
- 2) The end reminder signal will beep 3 times (once every minute).
- 3) The current time is displayed again.

 **Never** switch the microwave oven on when it is empty.

 If you wish to heat a dish for a short period of time at maximum power (750 W), simply press the **+30s** button once for each 30 seconds of cooking time. The oven starts immediately.

## POWER LEVELS

You can choose among the power levels below.

Power Level	Output	
	MWO	GRILL
HIGH	750 W	-
MEDIUM HIGH	600 W	-
MEDIUM	450 W	-
MEDIUM LOW	300 W	-
DEFROST (❄️)	180 W	-
LOW/KEEP WARM	100 W	-
GRILL	-	950 W
COMBI I (🔊🔥)	600 W	950 W
COMBI II (🔊🔥)	450 W	950 W
COMBI III (🔊🔥)	300 W	950 W

 If you select higher power level, the cooking time must be decreased.  
If you select lower power level, the cooking time must be increased.

## STOPPING THE COOKING

You can stop cooking at any time to check the food.

1. To stop temporarily;  
Open the door.

**Result :** Cooking stops. To resume cooking, close the door and press **Start** (◊) again.

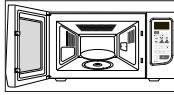

2. To stop completely;  
Press the **Stop** (⊖) button.

**Result :** The cooking stops.  
If you wish to cancel the cooking settings, press the **Stop** (⊖) button again.



- ☞ You can cancel any setting before starting cooking by simply pressing **Stop**.

## ADJUSTING THE COOKING TIME

You can increase the cooking time by pressing the +30s button once for each 30 seconds to be added.

Press the **+30s** button once for each 30 seconds to be added.



- ☞ You can not adjust the time during cooking when Auto modes are selected.

## USING THE INSTANT REHEAT/COOK FEATURE

With the Instant Reheat and Cook feature, the cooking time is set automatically and you do not have to press the Start button. You can adjust the number of servings by pressing the appropriate Instant Reheat and Cooking button the required number of times.

First, place the food in the centre of the turntable and close the door.

Press the **Instant Reheat and Cook** button which you want the required number of times.

**Result :** Cooking starts after about two seconds. When it has finished:

- 1) The oven beeps four times.
- 2) The end reminder signal will beep 3 times. (once every minute)
- 3) The current time is displayed again.







**Example:** Press the **Drinks** button once times to reheat one cups of coffee. Refer to the table on the next page for further details.



- ☞ Use only recipients that are microwave-safe.



## INSTANT REHEAT/COOK SETTINGS

The following table presents 5 Auto Reheat/Cook Programmes, quantities, standing times and appropriate recommendations.

Food/Button	Serving Size	Standing Time	Recommendations
<b>Ready Meals</b> (chilled)  	300-350 g 400-450 g	3 min.	Put on a ceramic plate and cover with microwave cling film. This programme is suitable for meals consisting of 3 components (e.g. meat with sauce, vegetables and a side dish like potatoes, rice or pasta).
<b>Drinks</b> (Coffee, milk, tea, water with room temperature)  	150 ml (1 cup) 250 ml (1 mug)	1-2 min.	Pour in to a ceramic cup and reheat uncovered. Place cup (150 ml) or mug (250 ml) in the centre of turntable, Stir carefully before and after standing time.
<b>Frozen Ready Meals</b> (frozen)  	300-350 g 400-450 g	4 min.	Take frozen ready meal and check if dish is suitable for microwave. Pierce film of ready meal. Put the frozen ready meal in the centre. This programme is suitable for frozen ready meals consisting of 3 components (e.g. meat with sauce, vegetables and a side dish like potatoes, rice or pasta).
<b>Frozen Fish Gratin</b> (frozen)  	200 g 400 g	2-3 min.	Put the frozen fish gratin into a suitable sized glass pyrex dish. Put the dish on the rack. This programme is suitable for frozen ready products consisting of fish fillets topped with vegetables and sauce.

Food/Button	Serving Size	Standing Time	Recommendations
<b>Frozen Mini Quich/Pizza</b> (frozen)  	150 g (4-6 pcs) 250 g (7-9 pcs)	-	Put the frozen mini-quiches or mini-pizzas evenly on the rack.
<b>Frozen Pasta Gratin</b> (frozen)  	200 g 400 g	2-3 min.	Put the frozen pasta gratin into a suitable sized glass pyrex dish. Put the dish on the rack. This programme is suitable for frozen pasta gratin such as lasagne, cannelloni or macaroni.

## USING THE AUTO RAPID DEFROST FEATURE

The Auto Rapid Defrost feature enables you to defrost meat, poultry, fish. The defrost time and power level are set automatically. You simply select the programme and the weight.

 Use only dishes that are microwave-safe.

First, place the frozen food in the centre of the turntable and close the door.

1. Select the type of food that you are cooking by pressing the **Rapid Defrost** (☼☼) button one or more times. (Refer to the table on the opposite page for further details)

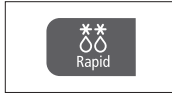

2. Select the food weight by pressing the **kg** and **g** button. It is possible to set up to a maximum of 2000 g.



3. Press the **Start** (◊) button.

### Result :

- Defrosting begins.
- The oven beeps halfway through defrosting to remind you to turn the food over.
- Press **Start** (◊) button again to finish defrosting.



 You can also defrost food manually. To do so, select the microwave cooking/reheating function with a power level of 180 W. Refer to the section entitled "Cooking/Reheating" on page 15 for further details.

## AUTO RAPID DEFROST SETTINGS

The following table presents the various Auto Rapid Defrost programmes, quantities, standing times and appropriate recommendations.

Remove all kinds of package material before defrosting. Place meat, poultry, fish and fruit/Berry on a ceramic plate.

Code/Food	Portion	Standing Time	Recommendations
1. Meat	100-2000 g	20-90 min.	Shield the edges with aluminium foil. Turn the meat over, when the oven beeps. This programme is suitable for beef, lamb, pork, steaks, chops, minced meat.
2. Poultry	100-2000 g	20-90 min.	Shield the leg and wing tips with aluminium foil. Turn the poultry over, when the oven beeps. This programme is suitable for whole chicken as well as for chicken portions.
3. Fish	100-2000 g	20-80 min.	Shield the tail of a whole fish with aluminium foil. Turn the fish over, when the oven beeps. This programme is suitable for whole fishes as well as for fish fillets.
4. Fruit/Berry	100-600 g	5-20 min.	Spread fruits evenly into a flat glass dish. This programme is suitable for all kind of fruits.

 Select the Manual Defrosting function with a power level of 180 W if you want to defrost food manually. For further details on manual defrosting and defrosting time, refer to the page 29.

## CHOOSING THE ACCESSORIES

Use microwave-safe recipients; do not use plastic containers, dishes, paper cups, towels, etc.

If you wish to select the combined cooking mode (grill and microwave), use only dishes that are microwave-safe and oven-proof. Metallic cookware or utensils may damage your oven.

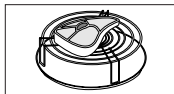

 For further details on suitable cookware and utensils, refer to the Cookware Guide on page 22.

## GRILLING

The grill enables you to heat and brown food quickly, without using microwaves. To this aim, a grill rack is supplied with your microwave oven.

1. Preheat the grill to the required temperature, by pressing the **Grill** (U) button, time setting (**10 min, 1 min** and **10 s**) and **Start** button.



2. Open the door and place the food on the rack.

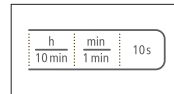

3. Place the food on the rack in the oven. Press the **Grill** (U) button. Select the cooking time by pressing the **10 min, 1 min** and **10 s** buttons. (The maximum grilling time is 60 minutes.)

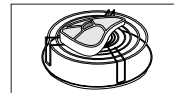



4. Press the **Start** (◇) button.

**Result :** The oven light comes on and the turntable starts rotating.

- 1) Cooking starts and when it has finished the oven beeps four times.
- 2) The end reminder signal will beep 3 times (once every minute).
- 3) The current time is displayed again.





 Do not worry if the heater turns off and on while grilling. This system is designed to prevent overheating of the oven.

 Always use oven gloves when touching the dishes in the oven, as they will be very hot.

## COMBINING MICROWAVES AND THE GRILL

You can also combine microwave cooking with the grill, to cook quickly and brown at the same time.

-  **ALWAYS** use microwave-safe and oven-proof cookware. Glass or ceramic dishes are ideal as they allow the microwaves to penetrate the food evenly.
-  **ALWAYS** use oven gloves when touching the recipients in the oven, as they will be very hot.

1. Open the oven door by pushing the large button in the bottom right-hand corner of the control panel. Place the food on the rack and the rack on the turntable. Close the door.

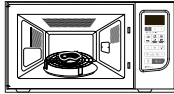

2. Press the **Combi** (🔥🌀) button.

**Result :** The following indications are displayed:  
 (microwave and grill mode)  
**600 W** (out power)



-  Select the appropriate **power level** by pressing the **Combi** (🔥🌀) button again until the corresponding power level is displayed.

-  You cannot set the temperature of the grill.

3. Set the cooking time by pressing the **10 min**, **1 min** and **10 s** buttons. The maximum cooking time is 60 minutes.



4. Press the **Start** (▶) button.

**Result :** Combination cooking starts. When it has finished.

- 1) The oven beeps four times.
- 2) The end reminder signal will beep 3 times (once every minute).
- 3) The current time is displayed again.



-  The maximum microwave power for the combined microwave and grill mode is 600 W.

## SWITCHING THE BEEPER OFF

You can switch the beeper off whenever you want.

1. Press the **Stop** (⏻) and **Start** (▶) buttons at the same time.

**Result :** The oven will not beep each time you press a button.



2. To switch the beeper back on, press the **Stop** (⏻) and **Start** (▶) buttons again at the same time.

**Result :** The oven operates with the beeper on again.



## SAFETY-LOCKING YOUR MICROWAVE OVEN

Your microwave oven is fitted with a special Child Safety programme, which enables the oven to be “locked” so that children or anyone unfamiliar with it cannot operate it accidentally.

The oven can be locked at any time.

1. Press the **Stop** (⏻) and **Clock** (🕒) buttons at the same time.

**Result :** The oven is locked (no functions can be selected).



2. To unlock the oven, press the **Stop** (⏻) and **Clock** (🕒) buttons again at the same time.

**Result :** The oven can be used normally.



## MULTISTAGE COOKING

Your microwave oven can be programmed to cook food up to three stages.

**Example:** You wish to defrost food and cook it without having to reset the oven after each stage. You can thus defrost and cook a 500 g fish in three stages:

- Defrosting
- Cook I
- Cook II

 You can set between two and three stages in multistage cooking. If you set three stage, the first stage must be defrosting. Don't press (◊) button until you've set the final stage.

1. Press the **Rapid** (\*\*\*) button once or more times.

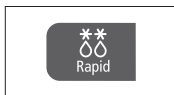

2. Set the weight by pressing the **kg** and **g** buttons the appropriate number of times (500 g in the example).



3. Press the **Power Level** (P) button.

The microwave mode (I) :

 ; if necessary, set the power level by pressing the **Power Level** (P) button again one or more times. (600 W in the example)

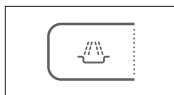

4. Set the cooking time by pressing the **10 min**, **1 min** and **10 s** buttons the appropriate number of times (4 minutes in the example).



5. Press the **Grill** (U) button.

The grill mode (II):



6. Set the cooking time by pressing the **10 min**, **1 min** and **10 s** buttons the appropriate number of times (5 minutes in the example).  
(The maximum grilling time is 60 minutes.)

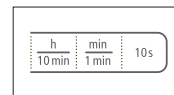

7. Press the **Start** (◊) button.

**Result :**

The three modes [defrosting and cooking (I, II)] are selected one after the other. According to the defrosting mode that you have chosen, the oven may beep halfway through defrosting to remind you to turn the food over. When cooking is over, the oven beeps four times.

- The end reminder signal will beep 3 times (once every minute).
- The current time is displayed again.



## COOKWARE GUIDE

To cook food in the microwave oven, the microwaves must be able to penetrate the food, without being reflected or absorbed by the dish used. Care must therefore be taken when choosing the cookware. If the cookware is marked microwave-safe, you do not need to worry. The following table lists various types of cookware and indicates whether and how they should be used in a microwave oven.

Cookware	Microwave-Safe	Comments
<b>Aluminum foil</b>	✓ ✗	Can be used in small quantities to protect areas against overcooking. Arcing can occur if the foil is too close to the oven wall or if too much foil is used.
<b>Browning plate</b>	✓	Do not preheat for more than eight minutes.
<b>China and earthenware</b>	✓	Porcelain, pottery, glazed earthenware and bone china are usually suitable, unless decorated with a metal trim.
<b>Disposable polyester cardboard dishes</b>	✓	Some frozen foods are packaged in these dishes.
<b>Fast-food packaging</b>		
<ul style="list-style-type: none"> <li>Polystyrene cups containers</li> </ul>	✓	Can be used to warm food. Overheating may cause the polystyrene to melt.
<ul style="list-style-type: none"> <li>Paper bags or newspaper</li> </ul>	✗	May catch fire.
<ul style="list-style-type: none"> <li>Recycled paper or metal trims</li> </ul>	✗	May cause arcing.
<b>Glassware</b>		

Cookware	Microwave-Safe	Comments
<ul style="list-style-type: none"> <li>Oven-to-table ware</li> <li>Fine glassware</li> <li>Glass jars</li> </ul>	✓	Can be used, unless decorated with a metal trim.
	✓	Can be used to warm foods or liquids. Delicate glass may break or crack if heated suddenly.
	✓	Must remove the lid. Suitable for warming only.
<b>Metal</b>		
<ul style="list-style-type: none"> <li>Dishes</li> <li>Freezer bag twist ties</li> </ul>	✗	May cause arcing or fire.
	✗	
<b>Paper</b>		
<ul style="list-style-type: none"> <li>Plates, cups, napkins and Kitchen paper</li> <li>Recycled paper</li> </ul>	✓	For short cooking times and warming. Also to absorb excess moisture.
	✗	May cause arcing.
<b>Plastic</b>		
<ul style="list-style-type: none"> <li>Containers</li> <li>Cling film</li> <li>Freezer bags</li> </ul>	✓	Particularly if heat-resistant thermoplastic. Some other plastics may warp or discolour at high temperatures. Do not use Melamine plastic.
	✓	Can be used to retain moisture. Should not touch the food. Take care when removing the film as hot steam will escape.
	✓ ✗	Only if boilable or oven-proof. Should not be airtight. Prick with a fork, if necessary.

Cookware	Microwave-Safe	Comments
Wax or grease-proof paper	✓	Can be used to retain moisture and prevent spattering.

- ✓ : Recommended  
 ✓X : Use Caution  
 X : Unsafe

## COOKING GUIDE

### MICROWAVES

Microwave energy actually penetrates food, attracted and absorbed by its water, fat and sugar content.

The microwaves cause the molecules in the food to move rapidly. The rapid movement of these molecules creates friction and the resulting heat cooks the food.

### COOKING

#### Cookware for microwave cooking:

Cookware must allow microwave energy to pass through it for maximum efficiency. Microwaves are reflected by metal, such as stainless steel, aluminium and copper, but they can penetrate through ceramic, glass, porcelain and plastic as well as paper and wood. So food must never be cooked in metal containers.

#### Food suitable for microwave cooking:

Many kinds of food are suitable for microwave cooking, including fresh or frozen vegetables, fruit, pasta, rice, grains, beans, fish, and meat. Sauces, custard, soups, steamed puddings, preserves, and chutneys can also be cooked in a microwave oven. Generally speaking, microwave cooking is ideal for any food that would normally be prepared on a hob. Melting butter or chocolate, for example (see the chapter with tips, techniques and hints).

#### Covering during cooking

To cover the food during cooking is very important, as the evaporated water rises as steam and contributes to cooking process. Food can be covered in different ways: e.g. with a ceramic plate, plastic cover or microwave suitable cling film.

#### Standing times

After cooking is over food the standing time is important to allow the temperature to even out within the food.

### Cooking Guide for frozen vegetables

Use a suitable glass pyrex bowl with lid. Cook covered for the minimum time - see table. Continue cooking to get the result you prefer. Stir twice during cooking and once after cooking. Add salt, herbs or butter after cooking. Cover during standing time.

Food	Portion	Power	Time (min.)	Standing Time (min.)	Instructions
Spinach	150 g	600 W	5½-6½	2-3	Add 15 ml (1 tablespoon) cold water.
Broccoli	300 g	600 W	10-11	2-3	Add 15 ml (1 tbsp.) cold water.
Peas	300 g	600 W	8-9	2-3	Add 15 ml (1 tbsp.) cold water.
Green Beans	300 g	600 W	10-11	2-3	Add 15 ml (1 tbsp.) cold water.
Mixed Vegetables (carrots/peas/corn)	300 g	600 W	9-10	2-3	Add 15 ml (1 tbsp.) cold water.
Mixed Vegetables (Chinese style)	300 g	600 W	8½-9½	2-3	Add 15 ml (1 tbsp.) cold water.

### Cooking Guide for rice and pasta

**Rice :** Use a large glass pyrex bowl with lid - rice doubles in volume during cooking. Cook covered. After the cooking time is over, stir before standing time and salt or add herbs and butter. Remark: the rice may not have absorbed all water after the cooking time is finished.

**Pasta :** Use a large glass pyrex bowl. Add boiling water, a pinch of salt and stir well. Cook uncovered. Stir occasionally during and after cooking. Cover during standing time and drain thoroughly afterwards.

Food	Portion	Power	Time (min.)	Standing Time (min.)	Instructions
White Rice (parboiled)	250 g	750 W	17-18	5	Add 500 ml cold water.
Brown Rice (parboiled)	250 g	750 W	22-23	5	Add 500 ml cold water.
Mixed Rice (rice + wild rice)	250 g	750 W	18-19	5	Add 500 ml cold water.
Mixed Corn (rice + grain)	250 g	750 W	19-20	5	Add 400 ml cold water.
Pasta	250 g	750 W	11-12	5	Add 1000 ml hot water.



## Cooking Guide for fresh vegetables

Use a suitable glass pyrex bowl with lid. Add 30-45 ml cold water (2-3 tbsp.) for every 250 g unless another water quantity is recommended - see table. Cook covered for the minimum time - see table. Continue cooking to get the result you prefer. Stir once during and once after cooking. Add salt, herbs or butter after cooking. Cover during a standing time of 3 minutes.

**Hint:** Cut the fresh vegetables into even sized pieces. The smaller they are cut, the quicker they will cook.

All fresh vegetables should be cooked using full microwave power (750 W).

Food	Portion	Time (min.)	Standing Time (min.)	Instructions
Broccoli	250 g 500 g	5-5½ 8½-9	3	Prepare even sized florets. Arrange the stems to the centre.
Brussels Sprouts	250 g	6½-7½	3	Add 60-75 ml (5-6 tbsp.) water.
Carrots	250 g	5-6	3	Cut carrots into even sized slices.
Cauliflower	250 g 500 g	5½-6 9½-10	3	Prepare even sized florets. Cut big florets into halves. Arrange stems to the centre.
Courgettes	250 g	4-4½	3	Cut courgettes into slices. Add 30 ml (2 tbsp.) water or a knob of butter. Cook until just tender.
Egg Plants	250 g	4½-5	3	Cut egg plants into small slices and sprinkle with 1 tablespoon lemon juice.
Leeks	250 g	5-5½	3	Cut leeks into thick slices.

Food	Portion	Time (min.)	Standing Time (min.)	Instructions
Mushrooms	125 g 250 g	1½-2 3½-4	3	Prepare small whole or sliced mushrooms. Do not add any water. Sprinkle with lemon juice. Spice with salt and pepper. Drain before serving.
Onions	250 g	5-6	3	Cut onions into slices or halves. Add only 15 ml (1 tbsp.) water.
Pepper	250 g	4½-5	3	Cut pepper into small slices.
Potatoes	250 g 500 g	5-6 9-10	3	Weigh the peeled potatoes and cut them into similar sized halves or quarters.
Turnip Cabbage	250 g	5-5½	3	Cut turnip cabbage into small cubes.

## REHEATING

Your microwave oven will reheat food in a fraction of the time that conventional ovens hobs normally take.

Use the power levels and reheating times in the following chart as a guide. The times in the chart consider liquids with a room temperature of about +18 to +20 °C or a chilled food with a temperature of about +5 to +7 °C.

### Arranging and covering

Avoid reheating large items such as joint of meat - they tend to overcook and dry out before the centre is piping hot. Reheating small pieces will be more successful.

### Power levels and stirring

Some foods can be reheated using 750 W power while others should be reheated using 600 W, 450 W or even 300 W.

Check the tables for guidance. In general, it is better to reheat food using a lower power level, if the food is delicate, in large quantities, or if it is likely to heat up very quickly (mince pies, for example).

Stir well or turn food over during reheating for best results. When possible, stir again before serving.

Take particular care when heating liquids and baby foods. To prevent eruptive boiling of liquids and possible scalding, stir before, during and after heating. Keep them in the microwave oven during standing time. We recommend putting a plastic spoon or glass stick into the liquids. Avoid overheating (and therefore spoiling) the food.

It is preferable to underestimate cooking time and add extra heating time, if necessary.

### Heating and standing times

When reheating food for the first time, it is helpful to make a note of the time taken - for future reference.

Always make sure that the reheated food is piping hot throughout.

Allow food to stand for a short time after reheating - to let the temperature even out.

The recommended standing time after reheating is 2-4 minutes, unless another time is recommended in the chart.

Take particular care when heating liquids and baby food. See also the chapter with the safety precautions.

## REHEATING LIQUIDS

Always allow a standing time of at least 20 seconds after the oven has been switched off to allow the temperature to even out. Stir during heating, if necessary, and ALWAYS stir after heating. To prevent eruptive boiling and possible scalding, you should put a spoon or glass stick into the beverages and stir before, during and after heating.

## REHEATING BABY FOOD

**BABY FOOD:** Empty into a deep ceramic plate. Cover with plastic lid. Stir well after reheating! Let stand for 2-3 minutes before serving. Stir again and check the temperature. Recommended serving temperature: between 30-40 °C.

**BABY MILK:** Pour milk into a sterilised glass bottle. Reheat uncovered. Never heat a baby's bottle with teat on, as the bottle may explode if overheated. Shake well before standing time and again before serving! Always carefully check the temperature of baby milk or food before giving it to the baby. Recommended serving temperature: ca. 37 °C.

### REMARK:

Baby food particularly needs to be checked carefully before serving to prevent burns.

Use the power levels and times in the next table as a guide lines for reheating.

## Reheating Liquids and Food

Use the power levels and times in this table as a guide lines for reheating.

Food	Portion	Power	Time (min.)	Standing Time (min.)	Instructions
Drinks (coffee, milk, tea, water with room temperature)	150 ml (1 cup) 250 ml (1 mug)	750 W	1½-2 2-2½	1-2	Pour in to a ceramic cup and reheat uncovered. Place cup (150 ml) or mug (250 ml) in the centre of turntable, Stir carefully before and after standing time.
Soup (chilled)	250 g 450 g	750 W	3-3½ 4-4½	2-3	Pour into a deep ceramic plate. Cover with plastic lid. Stir well after reheating. Stir again before serving.
Stew (chilled)	350 g	600 W	5-6	2-3	Put stew in a deep ceramic plate. Cover with plastic lid. Stir occasionally during reheating and again before standing and serving.
Pasta with sauce (chilled)	350 g	600 W	4-5	3	Put pasta (e.g. spaghetti or egg noodles) on a flat ceramic plate. Cover with microwave cling film. Stir before serving.

Food	Portion	Power	Time (min.)	Standing Time (min.)	Instructions
Filled pasta with sauce (chilled)	350 g	600 W	4½-5½	3	Put filled pasta (e.g. ravioli, tortellini) in a deep ceramic plate. Cover with plastic lid. Stir occasionally during reheating and again before standing and serving.
Plated Meal (chilled)	300 g 400 g	600 W	5-6 6-7	3	Plate a meal of 2-3 chilled components on a ceramic dish. Cover with microwave cling-film.
Frozen Ready Meal	300 g 400 g	600 W	11½-12½ 13-14	4	Put microwave proof dish with frozen ready meal (-18 °C) on the turntable. Pierce film or cover with microwave cling film. After reheating stand for 4 minutes.

## Reheating Baby Food and Milk

Use the power levels and times in this table as guide lines for reheating.

Food	Portion	Power	Time	Standing Time (min.)	Instructions
Baby food (vegetables + meat)	190 g	600 W	30 sec.	2-3	Empty into ceramic deep plate. Cook covered. Stir after cooking time. Stand for 2-3 minutes. Before serving, stir well and check the temperature carefully.
Baby porridge (grain + milk + fruit)	190 g	600 W	20 sec.	2-3	Empty into ceramic deep plate. Cook covered. Stir after cooking time. Stand for 2-3 minutes. Before serving, stir well and check the temperature carefully.

Food	Portion	Power	Time	Standing Time (min.)	Instructions
Baby milk	100 ml 200 ml	300 W	30-40 sec. 1 min. to 1 min. 10 sec.	2-3	Stir or shake well and pour into a sterilized glass bottle. Place into the centre of turn-table. Cook uncovered. Shake well and stand for at least 3 minutes. Before serving, shake well and check the temperature carefully.

## DEFROSTING

Microwaves are an excellent way of defrosting frozen food. Microwaves gently defrost frozen food in a short period of time. This can be of great advantage, if unexpected guests suddenly show up.

Frozen poultry must be thoroughly thawed before cooking. Remove any metal ties and take it out of any wrapping to allow thawed liquid to drain away.

Put the frozen food on a dish without cover. Turn over half way, drain off any liquid and remove any giblets as soon as possible.

Check the food occasionally to make sure that it does not feel warm.

If smaller and thinner parts of the frozen food start to warm up, they can be shield by wrapping very small strips of aluminium foil around them during defrosting.

Should poultry start to warm up on the outer surface, stop thawing and allow it to stand for 20 minutes before continuing.

Leave the fish, meat and poultry to stand in order to complete defrosting. The standing time for complete defrosting will vary depending on the quantity defrosted. Please refer to the table below.

**Hint :** Flat food defrosts better than thick and smaller quantities need less time than bigger ones. Remember this hint while freezing and defrosting food.

For defrosting of frozen food with a temperature of about -18 to -20 °C, use the following table as a guide.

All frozen food should be defrosted using defrosting power level (180 W).

Food	Portion	Time (min.)	Standing Time (min.)	Instructions
<b>Meat</b>				
Minced beef	500 g	10-12	5-20	Place the meat on a flat ceramic plate. Shield thinner edges with aluminium foil. Turn over after half of defrosting time!
Pork steaks	250 g	7-8		

Food	Portion	Time (min.)	Standing Time (min.)	Instructions
<b>Poultry</b>				
Chicken pieces	500 g (2 pcs)	12-14	15-40	First, put chicken pieces first skin-side down, whole chicken first breast-side-down on a flat ceramic plate. Shield the thinner parts like wings and ends with aluminium foil. Turn over after half of defrosting time!
Whole chicken	1000 g	25-28		
<b>Fish</b>				
Fish fillets	250 g (2 pcs) 400 g (4 pcs)	6-7 11-13	5-20	Put frozen fish in the middle of a flat ceramic plate. Arrange the thinner parts under the thicker parts. Shield narrow ends with aluminium foil. Turn over after half of defrosting time!
<b>Fruits</b>				
Berries	250 g	6-7	5-10	Distribute fruits on a flat, round glass dish (with a large diameter).
<b>Bread</b>				
Bread rolls (each ca. 50 g)	2 pcs 4 pcs	1½-2 3-4	5-10	Arrange rolls in a circle or bread horizontally on kitchen paper in the middle of turntable. Turn over after half of defrosting time!
Toast/ Sandwich	250 g	4-5		
German bread (wheat + rye flour)	500 g	8-10		

## GRILL

The grill-heating element is located underneath the ceiling of the cavity. It operates while the door is closed and the turntable is rotating. The turntable's rotation makes the food brown more evenly. Preheating the grill for 4 minutes will make the food brown more quickly.

### **Cookware for grilling:**

Should be flameproof and may include metal. Do not use any type of plastic cookware, as it can melt.

### **Food suitable for grilling:**

Chops, sausages, steaks, hamburgers, bacon and gammon rashers, thin fish portions, sandwiches and all kinds of toast with toppings.

### **Important remark:**

Whenever the grill only mode is used, make sure that the grill-heating element is under the ceiling in the horizontal position and not on the back-wall in the vertical position. Please remember that food must be placed on the high rack, unless another instruction is recommended.

## MICROWAVE + GRILL

This cooking mode combines the radiant heat that is coming from the grill with the speed of microwave cooking. It operates only while the door is closed and the turntable is rotating. Due to the rotation of the turntable, the food browns evenly.

Three combination modes are available with this model:  
600 W + Grill, 450 W + Grill and 300 W + Grill.

### **Cookware for cooking with microwave + grill**

Please use cookware that microwaves can pass through. Cookware should be flameproof. Do not use metal cookware with combination mode. Do not use any type of plastic cookware, as it can melt.

### **Food suitable for microwave + grill cooking:**

Food suitable for combination mode cooking include all kinds of cooked food which need reheating and browning (e.g. baked pasta), as well as foods which require a short cooking time to brown the top of the food. Also, this mode can be used for thick food portions that benefit from a browned and crispy top (e.g. chicken pieces, turning them over half way through cooking). Please refer to the grill table for further details.

### **Important remark:**

Whenever the combination mode (microwave + grill) is used, make sure that the grill heating element is under the ceiling in the horizontal position and not on the back-wall in the vertical position. The food should be placed on the high rack, unless another instruction is recommended. Otherwise it has to be placed directly on the turntable. Please refer to the instructions in the following chart.

The food must be turned over, if it is to be browned on both sides.

## Grill Guide

Preheat the heater with the grill-function when grilling fresh and frozen food. Use the power levels and times in this table as guide lines for grilling.

Fresh Food	Portion	Preheat time (min.)	Power	1. Side Time (min)	2. Side Time (min)	Instructions
Toast Slices	4 pcs (4 x 25 g)	5	Grill only	6-7	5-6	Put the toast slices side by side on the rack.
Bread Rolls (already baked)	2-4 pieces	3	Grill only	3-4	2-3	Put bread rolls first with the bottom side up in a circle directly on the rack.
Grilled Tomatoes	250 g (2 pcs)	5	300 W + Grill	5½-6½	-	Cut tomatoes into halves. Put salt, pepper and some cheese on top. Arrange in a circle in a flat glass pyrex dish. Place dish on the rack.
Toast Hawaii	2 pcs (300 g)	5	300 W + Grill	7-9	-	Toast the bread slices first. Put the toast with topping (ham, pineapple, cheese slices) side by side on the rack. After cooking stand for 2-3 minutes.

Fresh Food	Portion	Preheat time (min.)	Power	1. Side Time (min)	2. Side Time (min)	Instructions
Chicken Wings (chilled)	400-500 g (6 pcs)	5	300 W + Grill	11-13	10-12	Prepare chicken pieces such as chicken wings or drumsticks with oil and spices. Put them in a circle on the rack with the bones to the middle. After grilling stand for 2-3 minutes.
Baked Potatoes	500 g	5	450 W + Grill	10-12	-	Cut potatoes into halves and put in a circle on the rack with the cut side to the grill. Brush cut side with olive oil and spices. After grilling stand for 3 minutes.
Frozen Pasta	400 g	-	600 W + Grill	14-16	3-4	Put the frozen pasta (-18 °C), e.g. lasagne, tortellini or cannelloni in a suitable sized glass pyrex dish and set on rack.

Fresh Food	Portion	Preheat time (min.)	Power	1. Side Time (min)	2. Side Time (min)	Instructions
Frozen Fish Gratin	400 g	-	600 W + Grill	16-18	3-4	Put the frozen fish gratin (-18 °C) in a suitable sized glass pyrex dish and set on rack.
Frozen Pizza Snacks	250 g (8 pcs)	-	300 W + Grill	12-13	-	Put the frozen pizza snacks (-18 °C) or mini quiches in a circle on the rack.
Frozen Streusel Cake	200-250 g (1-2 pcs)	-	300 W + Grill	4-6	-	Put the frozen cake pieces (-18 °C) side by side on rack. After defrosting stand for 5 minutes.

**MELTING BUTTER**

Put 50 g butter into a small deep glass dish. Cover with plastic lid. Heat for 30-40 seconds using 750 W, until butter is melted.

**MELTING CHOCOLATE**

Put 100 g chocolate into a small deep glass dish. Heat for 3-5 minutes, using 450 W until chocolate is melted. Stir once or twice during melting. Use oven gloves while taking out!

**MELTING CRYSTALLIZED HONEY**

Put 20 g crystallized honey into a small deep glass dish. Heat for 20-30 seconds using 300 W, until honey is melted.

**MELTING GELATINE**

Lay dry gelatine sheets (10 g) for 5 minutes into cold water. Put drained gelatine into a small glass pyrex bowl. Heat for 1 minute using 300 W. Stir after melting.

**COOKING GLAZE/ICING (FOR CAKE AND GATEAUX)**

Mix instant glaze (approximately 14 g) with 40 g sugar and 250 ml cold water. Cook uncovered in a glass pyrex bowl for 3½ to 4½ minutes using 750 W, until glaze/icing is transparent. Stir twice during cooking.

**COOKING JAM**

Put 600 g fruits (for example mixed berries) in a suitable sized glass pyrex bowl with lid. Add 300 g preserving sugar and stir well. Cook covered for 10-12 minutes using 750 W. Stir several times during cooking. Empty directly into small jam glasses with twist-off lids. Stand on lid for 5 minutes.

**COOKING PUDDING**

Mix pudding powder with sugar and milk (500 ml) by following the manufacturers instructions and stir well. Use a suitable sized glass pyrex bowl with lid. Cook covered for 6½ to 7½ minutes using 750 W. Stir several times well during cooking.

**BROWNING ALMOND SLICES**

Spread 30 g sliced almonds evenly on a medium sized ceramic plate. Stir several times during browning for 3½ to 4½ minutes using 600 W. Let it stand for 2-3 minutes in the oven. Use oven gloves while taking out!



## CLEANING YOUR MICROWAVE OVEN

The following parts of your microwave oven should be cleaned regularly to prevent grease and food particles from building up:

- Inside and outside surfaces
- Door and door seals
- Turntable and Roller rings

 **ALWAYS** ensure that the door seals are clean and the door closes properly.

 Failure to maintain the oven in a clean condition could lead to deterioration of the surface that could adversely affect the of the appliance and possibly result in a hazardous situation.

1. Clean the outside surfaces with a soft cloth and warm, soapy water. Rinse and dry.
2. Remove any splashes or stains on the inside surfaces or on the roller ring with a soapy cloth. Rinse and dry.
3. To loosen hardened food particles and remove smells, place a cup of diluted lemon juice on the turntable and heat for ten minutes at maximum power.
4. Wash the dishwasher-safe plate whenever necessary.

 **DO NOT** spill water in the vents. NEVER use any abrasive products or chemical solvents. Take particular care when cleaning the door seals to ensure that no particles:

- Accumulate
- Prevent the door from closing correctly

 **Clean the** microwave oven cavity right after each use with a mild detergent solution, but let the microwave oven cool down before cleaning in order to avoid injury.

## STORING AND REPAIRING YOUR MICROWAVE OVEN

A few simple precautions should be taken when storing or having your microwave oven serviced.

The oven must not be used if the door or door seals are damaged:

- Broken hinge
- Deteriorated seals
- Distorted or bent oven casing

Only a qualified microwave service technician should perform repair.

 **NEVER** remove the outer casing from the oven. If the oven is faulty and needs servicing or you are in doubt about its condition:

- Unplug it from the wall socket
- Contact the nearest after-sales service centre

 If you wish to store your oven away temporarily, choose a dry, dust-free place.

**Reason :** Dust and damp may adversely affect the working parts in the oven.

 This microwave oven is not intended for commercial use.

## TECHNICAL SPECIFICATIONS

SAMSUNG strives to improve its products at all times. Both the design specifications and these user instructions are thus subject to change without notice.

<b>Model</b>	<b>GW73C</b>
<b>Power source</b>	230 V ~ 50 Hz
<b>Power consumption</b>	
Microwave	1100 W
Grill	950 W
Combined mode	2050 W
<b>Output power</b>	100 W / 750 W (IEC-705)
<b>Operating frequency</b>	2450 MHz
<b>Magnetron</b>	OM75S(31)
<b>Cooling method</b>	Cooling fan motor
<b>Dimensions (W x H x D)</b>	
Outside	489 x 275 x 410 mm
Oven cavity	330 x 187 x 320 mm
<b>Volume</b>	20 liter
<b>Weight</b>	
Net	13.5 kg approx

**English**



**Correct Disposal of This Product  
(Waste Electrical & Electronic Equipment)**

(Applicable in the European Union and other European countries with separate collection systems)

This marking on the product, accessories or literature indicates that the product and its electronic accessories (e.g. charger, headset, USB cable) should not be disposed of with other household waste at the end of their working life. To prevent possible harm to the environment or human health from uncontrolled waste disposal, please separate these items from other types of waste and recycle them responsibly to promote the sustainable reuse of material resources.

Household users should contact either the retailer where they purchased this product, or their local government office, for details of where and how they can take these items for environmentally safe recycling.

Business users should contact their supplier and check the terms and conditions of the purchase contract. This product and its electronic accessories should not be mixed with other commercial wastes for disposal.

## NOTE

**NOTE**

---

**NOTE**

---



QUESTIONS OR COMMENTS

COUNTRY	CALL	OR VISIT US ONLINE AT
AUSTRIA	0810-SAMSUNG (7267864, € 0.07/Min)	www.samsung.com
CZECH	800-SAMSUNG (800-726786)	
HUNGARY	06-80-SAMSUNG (726-7864)	
ITALIA	800-SAMSUNG (726-7864)	
SLOVAKIA	0800-SAMSUNG (726-7864)	
SWEDEN	0771-726-7864 (SAMSUNG)	
U.K	0845-SAMSUNG (7267864)	
EIRE	0818-717100	