

CM3212 / KMS0712(×2)+KMS1812

SPLIT SYSTEM AIR CONDITIONER

Indoor Unit

Outdoor Unit

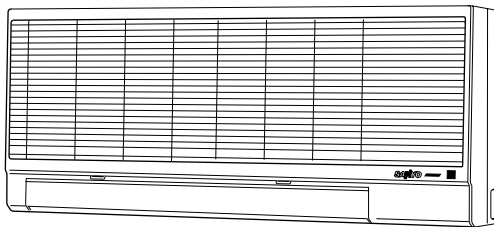
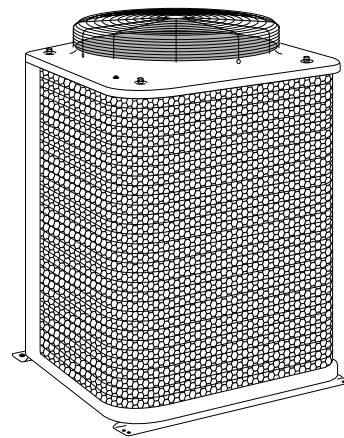
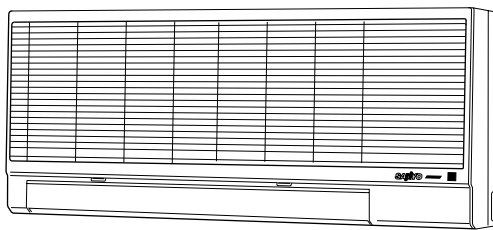

CM3212

KMS0712

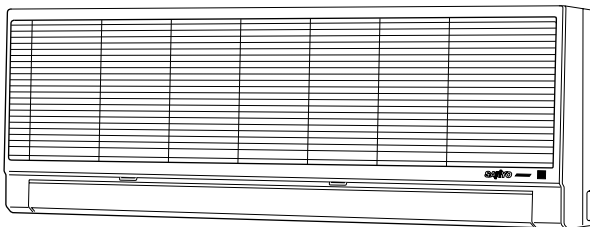

KMS1812

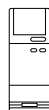

SERVICE MANUAL

CM3212 / KMS0712(×2)+KMS1812

(Basic Information)

IMPORTANT! Please Read Before Starting

This air conditioning system meets strict safety and operating standards. As the installer or service person, it is an important part of your job to install or service the system so it operates safely and efficiently.

For safe installation and trouble-free operation, you must:

- Carefully read this instruction booklet before beginning
- Follow each installation or repair step exactly as shown
- Observe all local, state, and national electrical codes
- Pay close attention to all danger, warning, and caution notices given in this manual



DANGER:

This symbol warns of an immediate hazard which will result in severe personal injury or death.



WARNING:

This symbol refers to a hazard or unsafe practice which can result in severe personal injury or death.



CAUTION:

This symbol refers to a hazard or unsafe practice which can result in personal injury or product or property damage.

If Necessary, Get Help

These instructions are all you need for most installation sites and maintenance conditions. If you require help for a special problem, contact our sales/service outlet or your certified dealer for additional instructions.

In Case of Improper Installation

The manufacturer shall in no way be responsible for improper installation or maintenance service, including failure to follow the instructions in this document.

SPECIAL PRECAUTIONS

When Wiring

ELECTRICAL SHOCK CAN CAUSE SEVERE PERSONAL INJURY OR DEATH. ONLY A QUALIFIED, EXPERIENCED ELECTRICIAN SHOULD ATTEMPT TO WIRE THIS SYSTEM.

- Do not supply power to the unit until all wiring and tubing are completed or reconnected and checked.
- Highly dangerous electrical voltages are used in this system. Carefully refer to the wiring diagram and these instructions when wiring. Improper connections and inadequate grounding can cause **accidental injury or death.**
- **Ground the unit** following local electrical codes.

- Connect all wiring tightly. Loose wiring may cause overheating at connection points and a possible fire hazard.

When Transporting

Be careful when picking up and moving the indoor and outdoor units. Get a partner to help, and bend your knees when lifting to reduce strain on your back. Sharp edges or thin aluminum fins on the air conditioner can cut your fingers.

When Installing...

...In a Ceiling or Wall

Make sure the ceiling/wall is strong enough to hold the unit's weight. It may be necessary to construct a strong wood or metal frame to provide added support.

...In a Room

Properly insulate any tubing run inside a room to prevent "sweating" that can cause dripping and water damage to walls and floors.

...In Moist or Uneven Locations

Use a raised concrete pad or concrete blocks to provide a solid, level foundation for the outdoor unit. This prevents water damage and abnormal vibration.

...In an Area with High Winds

Securely anchor unit down with bolts and metal frame. Provide a suitable air baffle.

...In a Snowy Area (for Heat Pump-type Systems)

Install the outdoor unit on a raised platform that is higher than drifting snow. Provide snow vents.

When Connecting Refrigerant Tubing

- Keep all tubing runs as short as possible.
- Use the flare method for connecting tubing.
- Apply refrigerant lubricant to the matching surfaces of the flare and union tubes before connecting them, then tighten the nut with a torque wrench for a leak-free connection.
- Check carefully for leaks before starting the test run.

NOTE:

Depending on the system type, liquid and gas lines may be either narrow or wide. Therefore, to avoid confusion the refrigerant tubing for your particular model is specified as either "narrow" or "wide" rather than as "liquid" or "gas."

When Servicing

- Turn the power OFF at the main power box (mains) before opening the unit to check or repair electrical parts.
- Keep your fingers and clothing away from any moving parts.
- Clean up the site after you finish, remembering to check that no scraps or bits of wiring have been left inside the unit being serviced.

Table of Contents

	Page
1. OPERATING RANGE	1
2. SPECIFICATIONS	2
Unit Specifications	2
Applicable Indoor Unit.....	3
3. DIMENSIONAL DATA	5
4. COOLING CAPACITY	7
5. REFRIGERANT FLOW DIAGRAM	11
6. ELECTRICAL DATA	12
● Electrical Characteristics	12
● Electrical Wiring Diagram.....	14

1. OPERATING RANGE

CM3212 / KMS0712(×2)+KMS1812

Temperature	Indoor Air Intake Temp.	Outdoor Air Intake Temp.
Maximum	95°F DB / 71°F WB	115°F DB
Minimum	67°F DB / 57°F WB	67°F DB

2. SPECIFICATIONS

Unit Specifications

Model No.		Outdoor unit	CM3212				
		Applicable indoor unit	KMS0712, KMS1812				
Performance	No. of indoor units		1 unit – A	1 unit – B	2 units – A + A	2 units – A + B	3 units – A + A + B
	Capacity	BTU/h	7,000 / 7,000	18,000 / 18,000	14,000 / 14,000	25,000 / 25,000	32,000 / 32,000
		kW	2.05 / 2.05	5.27 / 5.27	4.10 / 4.10	7.33 / 7.33	9.38 / 9.38
Electrical Rating	Phase, Frequency	Hz	Single, 60	Single, 60	Single, 60	Single, 60	Single, 60
	Voltage rating	V	230 / 208	230 / 208	230 / 208	230 / 208	230 / 208
	Available voltage range	V	187 to 253	187 to 253	187 to 253	187 to 253	187 to 253
	Running amperes	A	3.3 / 3.5	8.9 / 9.5	6.7 / 7.2	11.8 / 12.6	15.0 / 16.0
	Power input	W	750 / 720	2,000 / 1,950	1,540 / 1,490	2,700 / 2,600	3,400 / 3,300
	Power factor	%	99 / 99	99 / 99	99 / 99	99 / 99	99 / 99
	Starting amperes	A	24	56	24 × 2	24 + 56	24 × 2 + 56
	S. E. E. R.	BTU/Wh	10.0 / 10.0	10.0 / 10.0	10.0 / 10.0	10.0 / 10.0	10.0 / 10.0
Features	Fan speeds		Automatic (2)				
	Compressor ... number		Rotary, 500 W ... 2 / 1,400 W ... 1				
	Refrigerant amount charged at shipment	lbs. (kg)	R-22: 1.83 × 2 (0.83 × 2) / 4.14 (1.88)				
	Refrigerant control		Capillary tube				
	Operation sound (Outdoor unit)	dB-A	62				
	Refrigerant tubing connections		Flare type				
	Max. allowable tubing length at shipment	ft. (m)	33 (10)				
	Limit of tubing length	ft. (m)	7,000 BTU: 50 (15) / 18,000 BTU: 65 (20)				
	Limit of elevation difference between the 2 units	ft. (m)	23 (7)				
	Refrigerant tube o.d.	Narrow tube in. (mm)	1/4 (6.35)				
	Wide tube in. (mm)	7,000 BTU: 3/8 (9.52) / 18,000 BTU: 1/2 (12.7)					
Refrigerant tube kit		Optional					
Dimensions & Weight	Height	in. (mm)	32-1/16 (815)				
	Width	in. (mm)	26-3/8 (670)				
	Depth	in. (mm)	26-3/8 (670)				
	Net weight	lbs. (kg)	220 (99)				
	Shipping volume	cu. ft. (cu. m)	19.5 (0.552)				
	Shipping weight (Approx.)	lbs. (kg)	242 (110)				

DATA SUBJECT TO CHANGE WITHOUT NOTICE.

Remarks: Rating conditions are: Outside air temperature 95°F DB/75°F WB

Indoor unit entering air temperature 80°F DB/67°F WB

Applicable Indoor Unit

Model No.		KMS0712	
Type		Wall-mounted	
Performance			Cooling
	Capacity	BTU/h	7,000 / 7,700
		kW	2.05 / 2.05
	Air circulation (High)	cu. ft./min.	220 / 210
Moisture removal (High)	pints/h	2.2 / 2.1	
Electrical Rating	Phase, Frequency		Hz
	Voltage rating		V
	Available voltage range		V
Features	Controls		Microprocessor
	Control unit		Wireless remote control unit
	Temperature control		IC thermostat
	Timer		ON/OFF 24-hours & Program
	Fan speeds		3
	Air deflector		Horizontal / Vertical
	Air filter		Manual / Manual
	Air filter		Washable, easy access
	Operation sound		Hi / Me / Lo
	Operation sound		dB-A
	Refrigerant tubing connections		Flare type
	Refrigerant tube o.d.		Narrow tube
		Wide tube	in. (mm)
Refrigerant tube kit		Optional	
Accessories		Hanging wall bracket	
Dimensions & Weight	Height		in. (mm)
	Height		13-19/32 (345)
	Width		in. (mm)
	Width		31-1/2 (800)
	Depth		in. (mm)
	Depth		7-3/32 (180)
Net weight		lbs. (kg)	24 (11)
Shipping volume		cu. ft. (cu. m)	3.3 (0.093)
Shipping weight		lbs. (kg)	29 (13)

DATA SUBJECT TO CHANGE WITHOUT NOTICE.

Remarks: Rating conditions are: Outside air temperature 95°F DB/75°F WB

Indoor unit entering air temperature 80°F DB/67°F WB

Applicable Indoor Unit

Model No.		KMS1812		
Type		Wall-mounted		
Performance			Cooling	
	Capacity	BTU/h	18,000 / 17,600	
		kW	5.27 / 5.16	
	Air circulation (High)	cu. ft./min.	440 / 420	
Moisture removal (High)	pints/h	5.3 / 5.2		
Electrical Rating	Phase, Frequency		Hz	
	Voltage rating		V	
	Available voltage range		V	
Features	Controls		Microprocessor	
	Control unit		Wireless remote control unit	
	Temperature control		IC thermostat	
	Timer		ON/OFF 24-hours & Program	
	Fan speeds		3	
	Air deflector		Horizontal / Vertical	
	Air filter		Washable, easy access	
	Operation sound		Hi / Me / Lo	
			dB-A	
	Refrigerant tubing connections		Flare type	
	Refrigerant tube o.d.	Narrow tube	in. (mm)	1/4 (6.35)
		Wide tube	in. (mm)	1/2 (12.7)
Refrigerant tube kit		Optional		
Accessories		Hanging wall bracket		
Dimensions & Weight	Height		in. (mm)	
	Width		in. (mm)	
	Depth		in. (mm)	
	Net weight		lbs. (kg)	
	Shipping volume		cu. ft. (cu. m)	
	Shipping weight		lbs. (kg)	

DATA SUBJECT TO CHANGE WITHOUT NOTICE.

Remarks: Rating conditions are: Outside air temperature 95°F DB/75°F WB
Indoor unit entering air temperature 80°F DB/67°F WB

3. DIMENSIONAL DATA

Outdoor Unit: CM3212

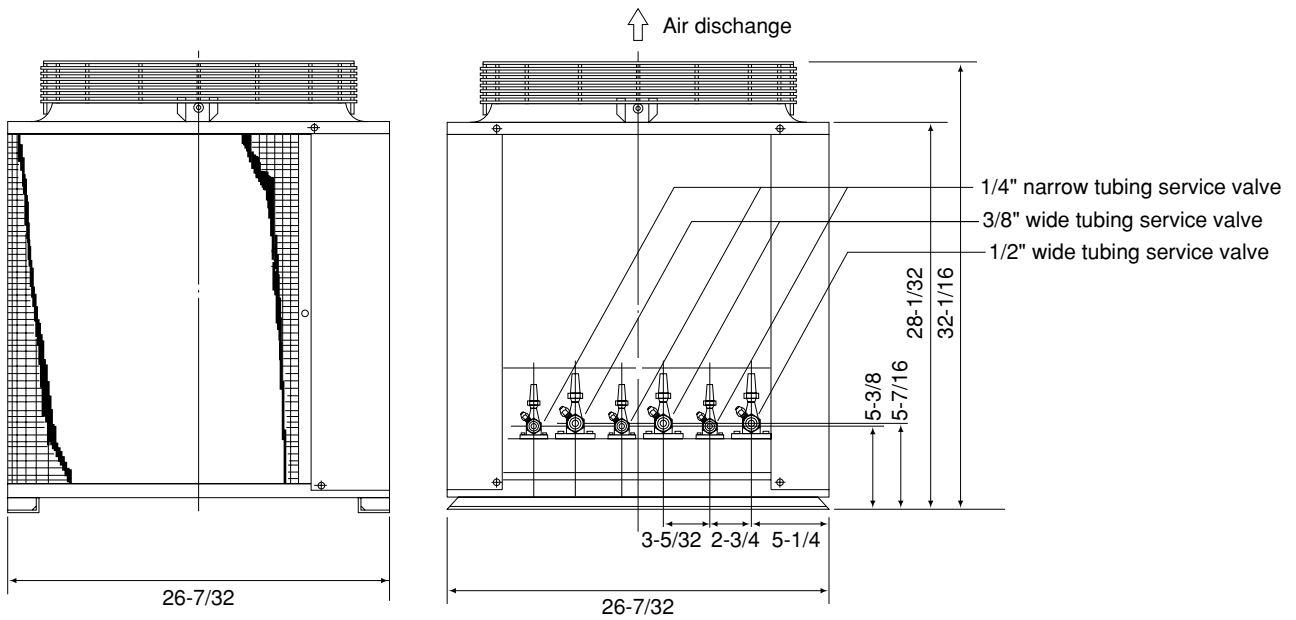
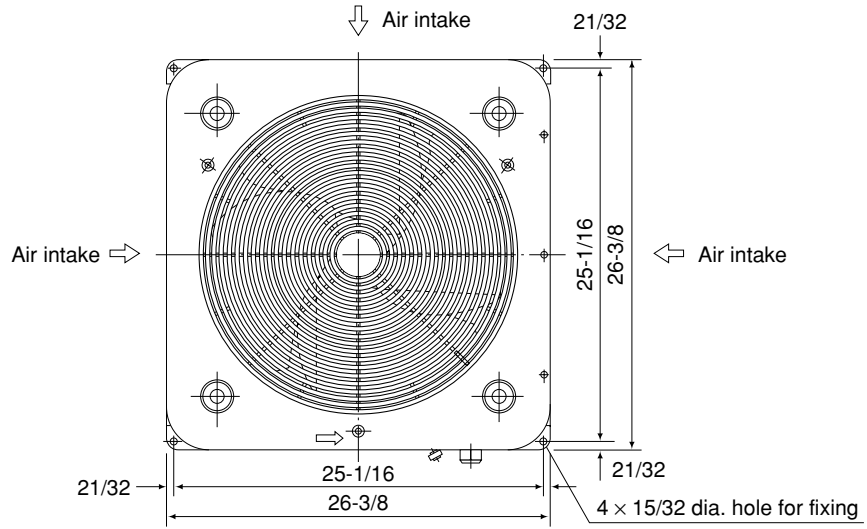

Indoor Unit: KMS0712

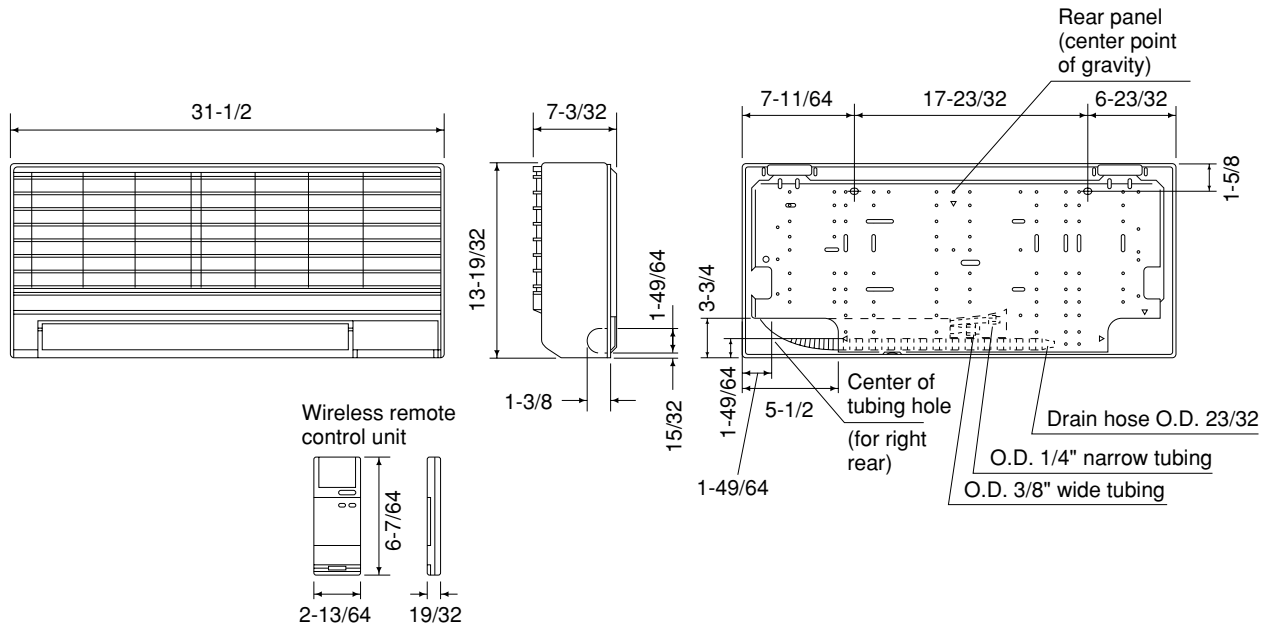

Indoor Unit: KMS1812

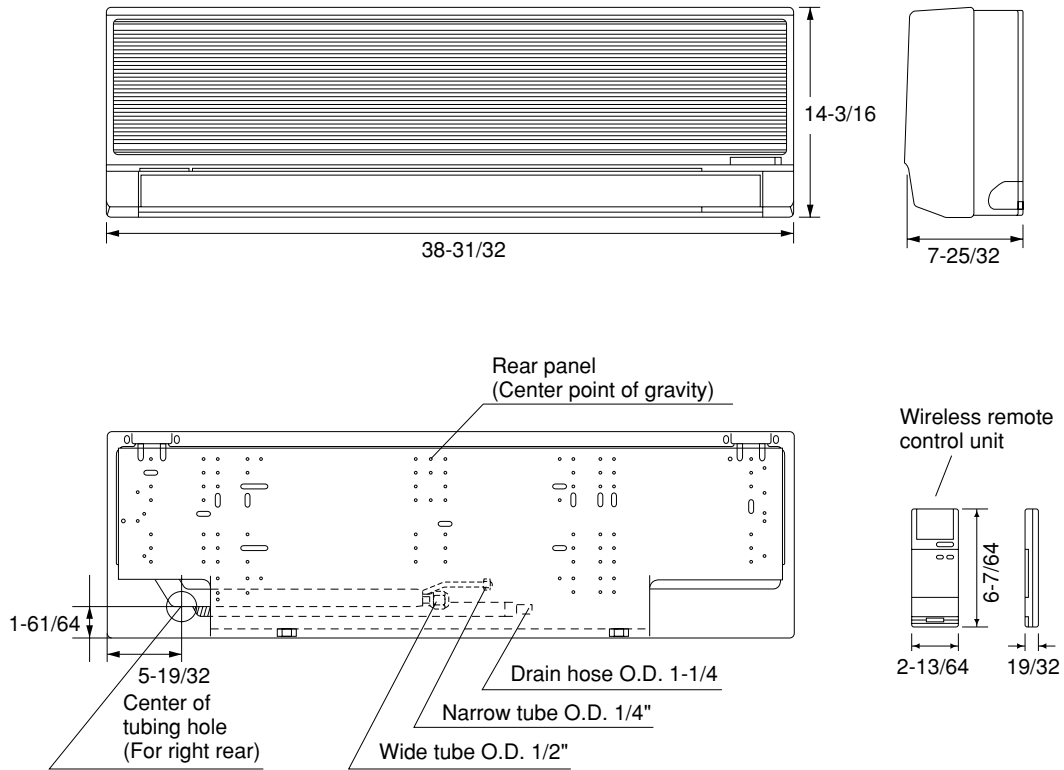

4. COOLING CAPACITY

230V

CM3622 / KMS0712×1

Rating Capacity: 7,000 BTU/H			Air Flow Rate: 220 CFM				
Evaporator		Condenser					
Ent. Temp. °F/(°C)		Ambient Temp. °F/(°C)					
WB	DB		75 (23.9)	85 (29.4)	95 (35.0)	105 (40.6)	115 (46.1)
59 (15.0)		TC	6,930	6,620	6,300	5,940	5,460
		kW	0.48	0.52	0.57	0.61	0.67
	72 (22.2)	SHC	5,290	5,130	4,980	4,810	4,590
	76 (24.4)	SHC	6,030	5,880	5,730	5,560	5,330
	80 (26.7)	SHC	6,810	6,620	6,300	5,940	5,460
	84 (28.9)	SHC	6,930	6,620	6,300	5,940	5,460
63 (17.2)		TC	7,170	6,940	6,670	6,310	5,810
		kW	0.48	0.53	0.57	0.62	0.69
	72 (22.2)	SHC	4,390	4,290	4,170	4,010	3,800
	76 (24.4)	SHC	5,130	5,030	4,910	4,750	4,540
	80 (26.7)	SHC	5,910	5,810	5,690	5,530	5,320
	84 (28.9)	SHC	6,650	6,550	6,430	6,270	5,810
67 (19.4)		TC	7,360	7,250	*7,000	6,620	6,610
		kW	0.48	0.53	0.58	0.63	0.70
	72 (22.2)	SHC	3,470	3,420	3,320	3,170	2,990
	76 (24.4)	SHC	4,210	4,160	4,060	3,910	3,730
	80 (26.7)	SHC	4,990	4,940	4,840	4,680	4,510
	84 (28.9)	SHC	5,730	5,680	5,580	5,430	5,250
71 (21.7)		TC	7,600	7,470	7,280	6,950	6,550
		kW	0.49	0.54	0.59	0.65	0.72
	72 (22.2)	SHC	2,520	2,470	2,400	2,280	2,140
	76 (24.4)	SHC	3,260	3,210	3,140	3,020	2,880
	80 (26.7)	SHC	4,040	3,990	3,920	3,800	3,660
	84 (28.9)	SHC	4,780	4,730	4,660	4,540	4,400
75 (23.9)		TC	7,740	7,660	7,490	7,220	6,930
		kW	0.50	0.55	0.60	0.66	0.73
	76 (24.4)	SHC	2,320	2,290	2,240	2,150	2,050
	80 (26.7)	SHC	3,100	3,070	3,010	2,920	2,830
	84 (28.9)	SHC	3,840	3,810	3,750	3,670	3,570
	88 (31.1)	SHC	4,580	4,550	4,500	4,410	4,310

TC: Total Cooling Capacity (BTU/H)

SHC: Sensible Heat Capacity (BTU/H)

kW: Compressor Input (kW)

Remarks: Rating conditions (* mark) are: Outside ambient temperature 95°F DB

Indoor unit entering air temperature 80°F DB/67°F WB

208V

CM3622 / KMS0712×1

Rating Capacity: 7,000 BTU/H			Air Flow Rate: 210 CFM				
Evaporator		Condenser					
Ent. Temp. °F/(°C)		Ambient Temp. °F/(°C)					
WB	DB		75 (23.9)	85 (29.4)	95 (35.0)	105 (40.6)	115 (46.1)
59 (15.0)		TC	6,930	6,620	6,300	5,940	5,460
		kW	0.47	0.51	0.56	0.60	0.66
	72 (22.2)	SHC	5,220	5,070	4,920	4,750	4,520
	76 (24.4)	SHC	5,940	5,780	5,630	5,460	5,240
	80 (26.7)	SHC	6,690	6,530	6,300	5,940	5,460
	84 (28.9)	SHC	6,930	6,620	6,300	5,940	5,460
63 (17.2)		TC	7,170	6,940	6,670	6,310	5,810
		kW	0.47	0.52	0.56	0.61	0.68
	72 (22.2)	SHC	4,360	4,250	4,130	3,970	3,760
	76 (24.4)	SHC	5,070	4,970	4,850	4,690	4,470
	80 (26.7)	SHC	5,820	5,720	5,590	5,430	5,220
	84 (28.9)	SHC	6,530	6,430	6,310	6,150	5,810
67 (19.4)		TC	7,360	7,250	*7,000	6,620	6,160
		kW	0.48	0.52	0.57	0.62	0.69
	72 (22.2)	SHC	3,460	3,410	3,310	3,160	2,970
	76 (24.4)	SHC	4,170	4,130	4,030	3,870	3,690
	80 (26.7)	SHC	4,920	4,870	4,770	4,620	4,400
	84 (28.9)	SHC	5,640	5,590	5,490	5,330	5,150
71 (21.7)		TC	7,600	7,470	7,280	6,950	6,550
		kW	0.48	0.53	0.58	0.64	0.70
	72 (22.2)	SHC	2,540	2,490	2,420	2,300	2,150
	76 (24.4)	SHC	3,250	3,210	3,140	3,020	2,870
	80 (26.7)	SHC	4,000	3,950	3,880	3,760	3,620
	84 (28.9)	SHC	4,720	4,670	4,600	4,480	4,330
75 (23.9)		TC	7,740	7,660	7,490	7,220	6,930
		kW	0.49	0.54	0.59	0.65	0.72
	76 (24.4)	SHC	2,340	2,310	2,260	2,170	2,070
	80 (26.7)	SHC	3,090	3,060	3,000	2,910	2,820
	84 (28.9)	SHC	3,800	3,770	3,720	3,630	3,530
	88 (31.1)	SHC	4,520	4,490	4,430	4,340	4,250

TC: Total Cooling Capacity (BTU/H)

SHC: Sensible Heat Capacity (BTU/H)

kW: Compressor Input (kW)

Remarks: Rating conditions (* mark) are: Outside ambient temperature 95°F DB

Indoor unit entering air temperature 80°F DB/67°F WB

230V

CM3622 / KMS1812

Rating Capacity: 18,000 BTU/H			Air Flow Rate: 440 CFM				
Evaporator		Condenser					
Ent. Temp. °F/(°C)		Ambient Temp. °F/(°C)					
WB	DB		75 (23.9)	85 (29.4)	95 (35.0)	105 (40.6)	115 (46.1)
59 (15.0)		TC	17,820	17,010	16,200	15,280	14,040
		kW	1.30	1.41	1.54	1.67	1.83
	72 (22.2)	SHC	12,350	11,900	11,460	10,970	10,340
	76 (24.4)	SHC	13,720	13,270	12,830	12,350	11,710
	80 (26.7)	SHC	15,150	14,700	14,260	13,780	13,140
	84 (28.9)	SHC	16,520	16,070	15,630	15,150	14,040
	88 (31.1)	SHC	17,820	17,010	16,200	15,280	14,040
63 (17.2)		TC	18,430	17,860	17,150	16,220	14,940
		kW	1.31	1.43	1.56	1.70	1.87
	72 (22.2)	SHC	10,550	10,260	9,910	9,450	8,840
	76 (24.4)	SHC	11,920	11,630	11,280	10,820	10,210
	80 (26.7)	SHC	13,350	13,060	12,710	12,250	11,640
	84 (28.9)	SHC	14,720	14,430	14,080	13,620	13,010
	88 (31.1)	SHC	16,090	15,800	15,450	14,990	14,380
67 (19.4)		TC	18,940	18,630	*18,000	17,010	15,840
		kW	1.32	1.45	1.58	1.72	1.91
	72 (22.2)	SHC	8,680	8,540	8,250	7,800	7,290
	76 (24.4)	SHC	10,050	9,910	9,620	9,180	8,660
	80 (26.7)	SHC	11,480	11,340	11,050	10,610	10,100
	84 (28.9)	SHC	12,850	12,710	12,420	11,980	11,470
	88 (31.1)	SHC	14,220	14,080	13,790	13,350	12,840
71 (21.7)		TC	19,530	19,210	18,720	17,870	16,830
		kW	1.33	1.46	1.60	1.77	1.95
	72 (22.2)	SHC	6,760	6,630	6,430	6,080	5,660
	76 (24.4)	SHC	8,130	8,000	7,800	7,450	7,040
	80 (26.7)	SHC	9,570	9,430	9,230	8,880	8,470
	84 (28.9)	SHC	10,940	10,800	10,600	10,260	9,840
	88 (31.1)	SHC	12,310	12,170	11,970	11,630	11,210
75 (23.9)		TC	19,910	19,690	19,260	18,580	17,820
		kW	1.36	1.49	1.63	1.81	2.00
	76 (24.4)	SHC	6,210	6,130	5,970	5,720	5,440
	80 (26.7)	SHC	7,640	7,560	7,400	7,150	6,880
	84 (28.9)	SHC	9,010	8,930	8,770	8,520	8,250
	88 (31.1)	SHC	10,390	10,300	10,140	9,890	9,620

TC: Total Cooling Capacity (BTU/H)

SHC: Sensible Heat Capacity (BTU/H)

kW: Compressor Input (kW)

Remarks: Rating conditions (* mark) are: Outside ambient temperature 95°F DB

Indoor unit entering air temperature 80°F DB/67°F WB

Rating Capacity: 17,600 BTU/H			Air Flow Rate: 420 CFM				
Evaporator		Condenser					
Ent. Temp. °F/(°C)		Ambient Temp. °F/(°C)					
WB	DB		75 (23.9)	85 (29.4)	95 (35.0)	105 (40.6)	115 (46.1)
59 (15.0)		TC	17,420	16,630	15,840	14,940	13,730
		kW	1.30	1.41	1.54	1.67	1.83
	72 (22.2)	SHC	10,040	9,520	9,030	8,470	7,750
	76 (24.4)	SHC	11,360	10,850	10,350	9,790	9,070
	80 (26.7)	SHC	12,740	12,230	11,730	11,170	10,450
	84 (28.9)	SHC	14,060	13,550	13,050	12,490	11,770
	88 (31.1)	SHC	15,380	14,870	14,370	13,820	13,090
63 (17.2)		TC	18,020	17,460	16,770	15,860	14,610
		kW	1.31	1.43	1.56	1.70	1.87
	72 (22.2)	SHC	8,030	7,690	7,300	6,780	6,090
	76 (24.4)	SHC	9,350	9,020	8,620	8,100	7,410
	80 (26.7)	SHC	10,730	10,400	10,000	9,480	8,790
	84 (28.9)	SHC	12,050	11,720	11,320	10,800	10,110
	88 (31.1)	SHC	13,370	13,040	12,640	12,120	11,430
67 (19.4)		TC	18,520	18,220	*17,600	16,630	15,490
		kW	1.32	1.45	1.58	1.72	1.91
	72 (22.2)	SHC	5,950	5,790	5,460	4,970	4,390
	76 (24.4)	SHC	7,270	7,110	6,790	6,290	5,710
	80 (26.7)	SHC	8,650	8,490	8,170	7,670	7,090
	84 (28.9)	SHC	9,970	9,810	9,490	8,990	8,410
	88 (31.1)	SHC	11,290	11,130	10,810	10,310	9,730
71 (21.7)		TC	19,100	18,780	18,300	17,480	16,460
		kW	1.33	1.46	1.60	1.77	1.95
	72 (22.2)	SHC	3,830	3,680	3,460	3,070	2,610
	76 (24.4)	SHC	5,160	5,000	4,780	4,390	3,930
	80 (26.7)	SHC	6,540	6,380	6,160	5,770	5,310
	84 (28.9)	SHC	7,860	7,700	7,480	7,090	6,630
	88 (31.1)	SHC	9,180	9,030	8,800	8,410	7,950
75 (23.9)		TC	19,470	19,250	18,830	18,160	17,420
		kW	1.36	1.49	1.63	1.81	2.00
	76 (24.4)	SHC	3,050	2,960	2,780	2,500	2,200
	80 (26.7)	SHC	4,430	4,340	4,160	3,880	3,580
	84 (28.9)	SHC	5,750	5,660	5,480	5,200	4,900
	88 (31.1)	SHC	7,070	6,980	6,800	6,520	6,220

TC: Total Cooling Capacity (BTU/H)

SHC: Sensible Heat Capacity (BTU/H)

kW: Compressor Input (kW)

Remarks: Rating conditions (* mark) are: Outside ambient temperature 95°F DB

Indoor unit entering air temperature 80°F DB/67°F WB

5. REFRIGERANT FLOW DIAGRAM

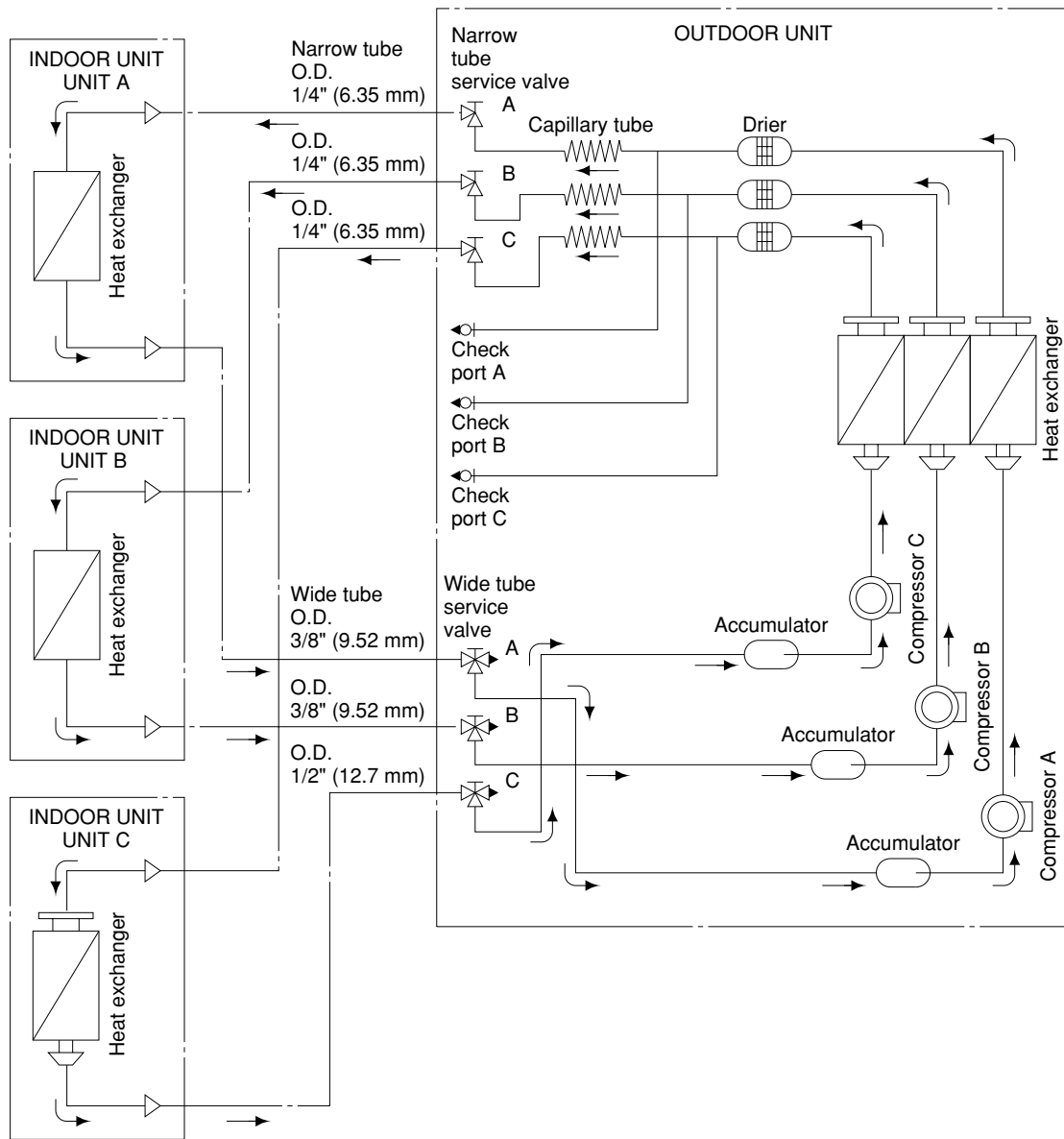

6. ELECTRICAL DATA

● Electrical Characteristics

CM3212 / KMS0712×1

Performance at 230/208V – 1ϕ – 60Hz	Indoor Unit		Outdoor Unit		Complete Unit
		Fan Motor	Fan Motor	Compressor	
Rating Conditions	A	0.15 / 0.14	0.62 / 0.56	2.53 / 2.80	3.3 / 3.5
	W	34 / 28	140 / 126	576 / 566	750 / 720
Locked-Rotor Amperes	A	0.19 / 0.18	1.95 / 1.77	22	—

Remarks: Rating conditions are: Outside air temperature 95°F DB/75°F WB
Indoor unit entering air temperature 80°F DB/67°F WB

CM3212 / KMS1812×1

Performance at 230/208V – 1ϕ – 60Hz	Indoor Unit		Outdoor Unit		Complete Unit
		Fan Motor	Fan Motor	Compressor	
Rating Conditions	A	0.4 / 0.4	1.45 / 1.42	7.05 / 7.68	8.9 / 9.5
	W	90 / 80	330 / 290	1,580 / 1,580	2,000 / 1,950
Locked-Rotor Amperes	A	0.45 / 0.40	1.95 / 1.77	54	—

Remarks: Rating conditions are: Outside air temperature 95°F DB/75°F WB
Indoor unit entering air temperature 80°F DB/67°F WB

CM3212 / KMS7012×2

Performance at 230/208V – 1ϕ – 60Hz	Indoor Units		Outdoor Unit		Complete Unit
		Fan Motor	Fan Motor	Compressor	
Rating Conditions	A	0.30 / 0.28	1.45 / 1.42	4.95 / 5.5	6.7 / 7.2
	W	68 / 56	330 / 290	1,142 / 1,144	1,540 / 1,490
Locked-Rotor Amperes	A	(0.19 / 0.18) × 2	1.95 / 1.77	22 × 2	—

Remarks: Rating conditions are: Outside air temperature 95°F DB/75°F WB
Indoor unit entering air temperature 80°F DB/67°F WB

CM3212 / KMS0712+KMS1812

Performance at 230/208V – 1Ø – 60Hz		Indoor Units	Outdoor Unit		Complete Unit
			Fan Motor	Compressor	
Rating Conditions	A	0.55 / 0.54	1.45 / 1.42	9.80 / 10.64	11.8 / 12.6
	W	124 / 108	330 / 290	2,246 / 2,202	2,700 / 2,600
Locked-Rotor Amperes	A	0.19 + 0.45 / 0.18 + 0.40	1.95 / 1.77	22 + 54	—

Remarks: Rating conditions are: Outside air temperature 95°F DB/75°F WB
Indoor unit entering air temperature 80°F DB/67°F WB

CM3212 / KMS7012×2+KMS1812

Performance at 230/208V – 1Ø – 60Hz		Indoor Units	Outdoor Unit		Complete Unit
			Fan Motor	Compressor	
Rating Conditions	A	0.70 / 0.68	1.45 / 1.42	12.85 / 13.90	15.0 / 16.0
	W	158 / 136	330 / 290	2,912 / 2,874	3,400 / 3,300
Locked-Rotor Amperes	A	0.19 + 0.19 + 0.45 / 0.18 + 0.18 + 0.40	1.95 / 1.77	22 + 22 + 54	—

Remarks: Rating conditions are: Outside air temperature 95°F DB/75°F WB
Indoor unit entering air temperature 80°F DB/67°F WB

● Electrical Wiring Diagram

Outdoor Unit: CM3212

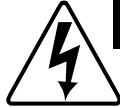

WARNING:

To avoid electrical shock hazard, be sure to disconnect power before checking, servicing and/or cleaning any electrical parts.

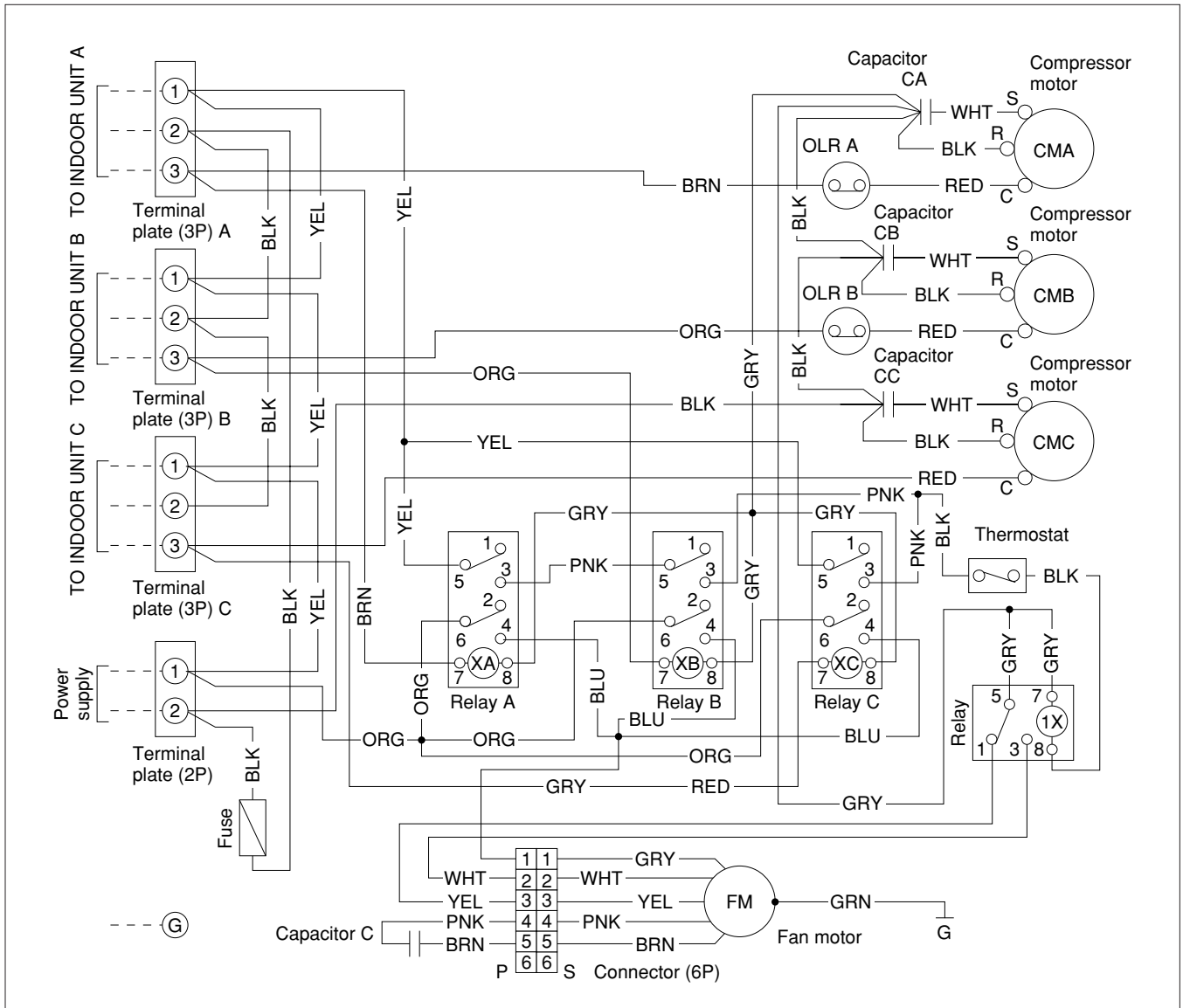



WARNING:

To avoid electrical shock hazard, be sure to disconnect power before checking, servicing and/or cleaning any electrical parts.

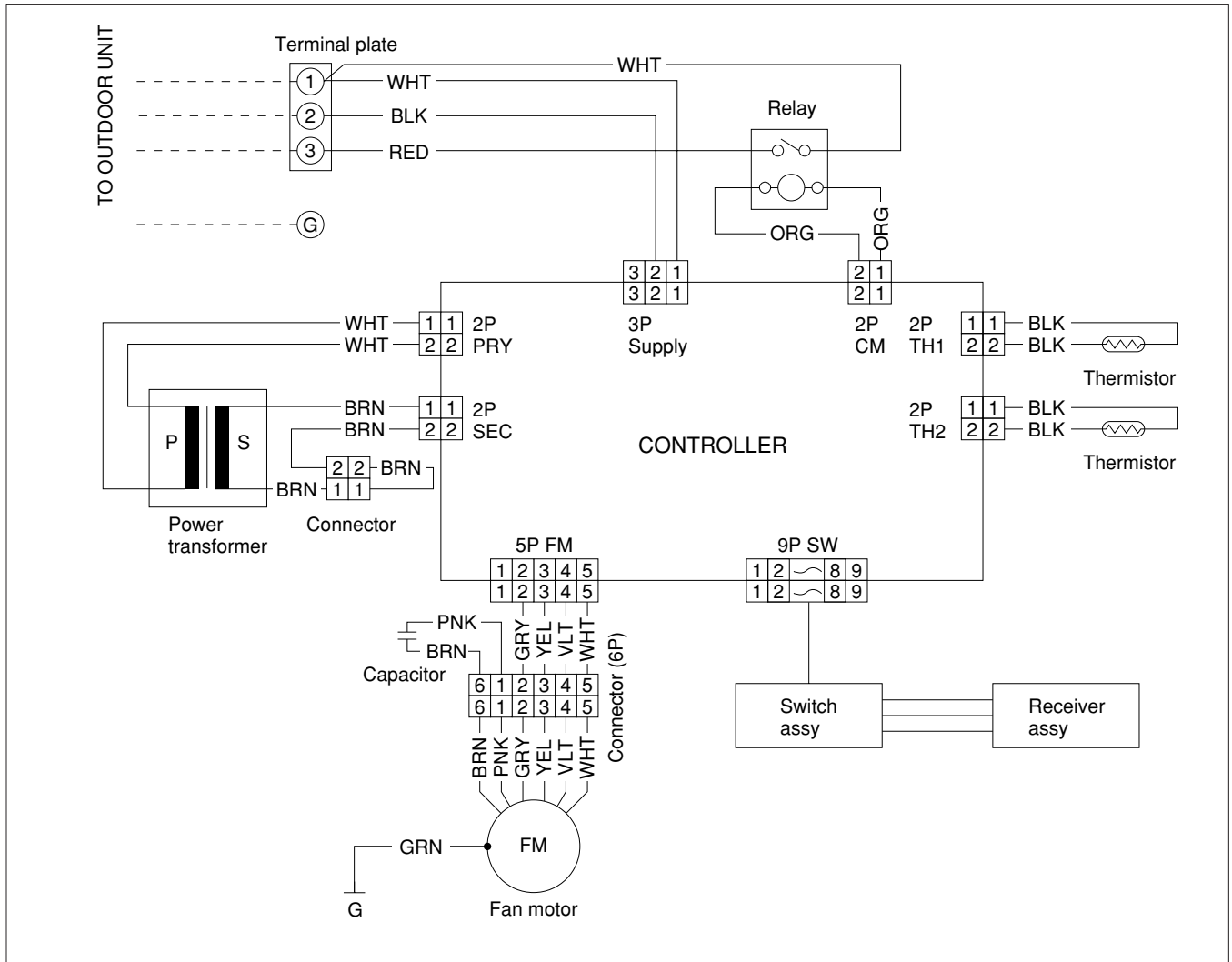



WARNING:

To avoid electrical shock hazard, be sure to disconnect power before checking, servicing and/or cleaning any electrical parts.

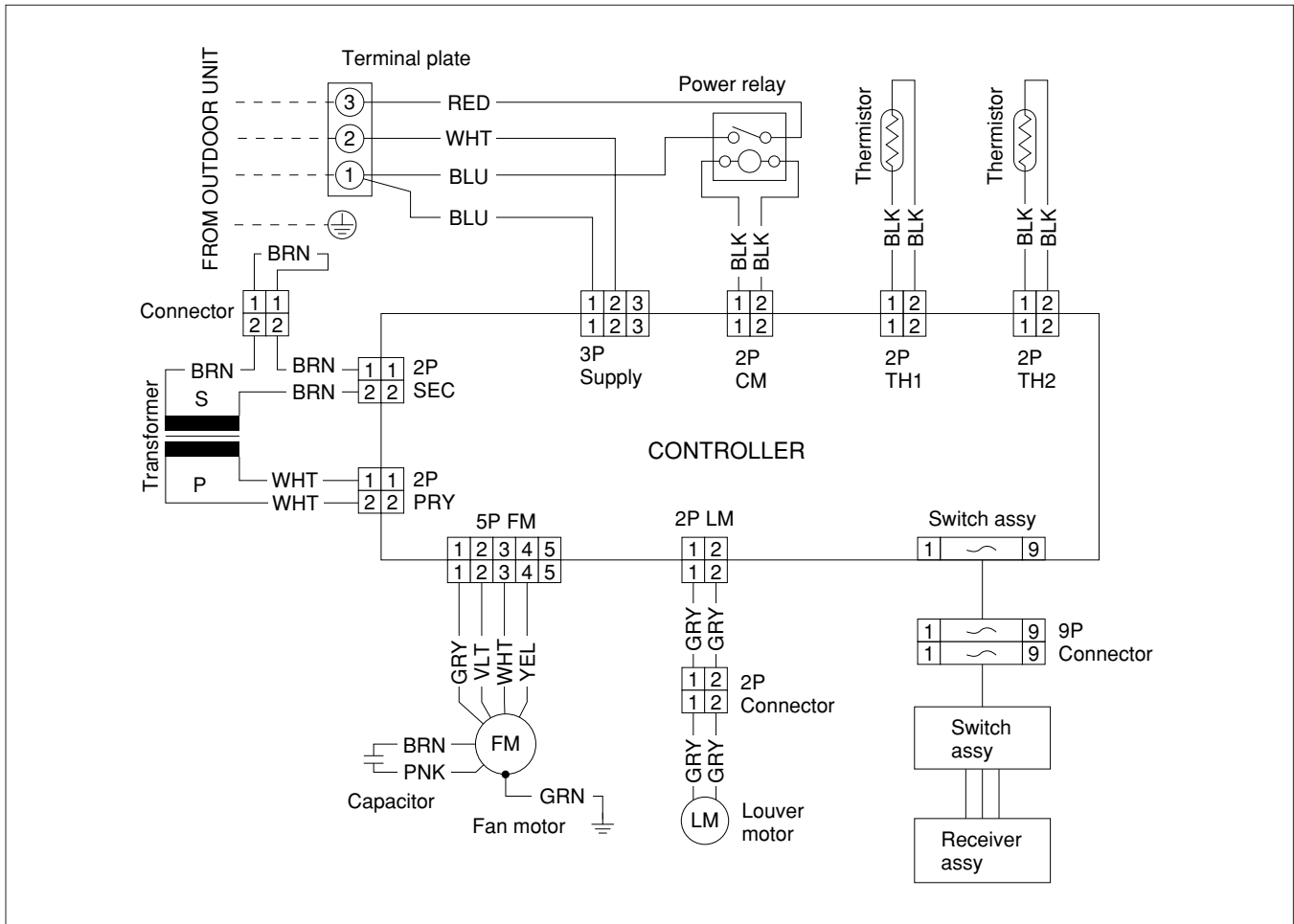

For parts or service contact



SFS Corporation: 1200 West Artesia Blvd., Compton, California 90220

In Canada SANYO Canada Inc.: Toronto, Ont. M4H 1M6

H406/12M

Printed in U.S.A.

WM-700699