

CMH1822 / KMH0922 (×2)

SPLIT SYSTEM AIR CONDITIONER

Indoor Unit

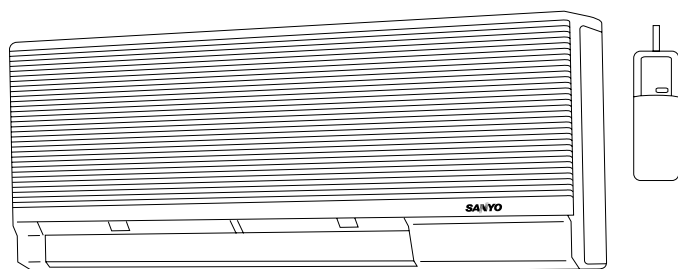
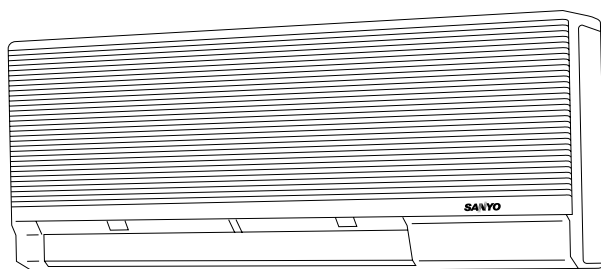

KMH0922

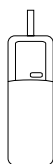

Outdoor Unit

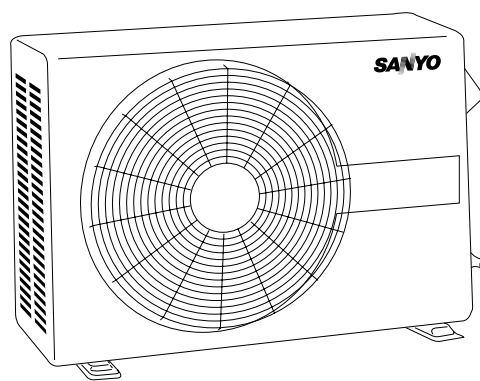

CMH1822

SERVICE MANUAL

CMH1822 / KMH0922 (×2)

(Basic Information)

IMPORTANT!

Please Read Before Starting

This air conditioning system meets strict safety and operating standards. As the installer or service person, it is an important part of your job to install or service the system so it operates safely and efficiently.

For safe installation and trouble-free operation, you must:

- Carefully read this instruction booklet before beginning
- Follow each installation or repair step exactly as shown
- Observe all local, state, and national electrical codes
- Pay close attention to all danger, warning, and caution notices given in this manual



This symbol warns of an immediate hazard which will result in severe personal injury or death.



This symbol refers to a hazard or unsafe practice which can result in severe personal injury or death.



This symbol refers to a hazard or unsafe practice which can result in personal injury or product or property damage.

If Necessary, Get Help

These instructions are all you need for most installation sites and maintenance conditions. If you require help for a special problem, contact our sales/service outlet or your certified dealer for additional instructions.

In Case of Improper Installation

The manufacturer shall in no way be responsible for improper installation or maintenance service, including failure to follow the instructions in this document.

SPECIAL PRECAUTIONS

When Wiring

ELECTRICAL SHOCK CAN CAUSE SEVERE PERSONAL INJURY OR DEATH. ONLY A QUALIFIED, EXPERIENCED ELECTRICIAN SHOULD ATTEMPT TO WIRE THIS SYSTEM.

- Do not supply power to the unit until all wiring and tubing are completed or reconnected and checked.
- Highly dangerous electrical voltages are used in this system. Carefully refer to the wiring diagram and these instructions when wiring. Improper connections and inadequate grounding can cause **accidental injury or death**.
- **Ground the unit** following local electrical codes.

- Connect all wiring tightly. Loose wiring may cause overheating at connection points and a possible fire hazard.

When Transporting

Be careful when picking up and moving the indoor and outdoor units. Get a partner to help, and bend your knees when lifting to reduce strain on your back. Sharp edges or thin aluminum fins on the air conditioner can cut your fingers.

When Installing...

...In a Ceiling or Wall

Make sure the ceiling/wall is strong enough to hold the unit's weight. It may be necessary to construct a strong wood or metal frame to provide added support.

...In a Room

Properly insulate any tubing run inside a room to prevent "sweating" that can cause dripping and water damage to walls and floors.

...In Moist or Uneven Locations

Use a raised concrete pad or concrete blocks to provide a solid, level foundation for the outdoor unit. This prevents water damage and abnormal vibration.

...In an Area with High Winds

Securely anchor unit down with bolts and metal frame. Provide a suitable air baffle.

...In a Snowy Area (for Heat Pump-type Systems)

Install the outdoor unit on a raised platform that is higher than drifting snow. Provide snow vents.

When Connecting Refrigerant Tubing

- Keep all tubing runs as short as possible.
- Use the flare method for connecting tubing.
- Apply refrigerant lubricant to the matching surfaces of the flare and union tubes before connecting them, then tighten the nut with a torque wrench for a leak-free connection.
- Check carefully for leaks before starting the test run.

NOTE:

Depending on the system type, liquid and gas lines may be either narrow or wide. Therefore, to avoid confusion the refrigerant tubing for your particular model is specified as either "narrow" or "wide" rather than as "liquid" or "gas."

When Servicing

- Turn the power OFF at the main power box (mains) before opening the unit to check or repair electrical parts.
- Keep your fingers and clothing away from any moving parts.
- Clean up the site after you finish, remembering to check that no scraps or bits of wiring have been left inside the unit being serviced.

Table of Contents

	Page
1. OPERATING RANGE	1
2. SPECIFICATIONS	2
Unit Specifications	2
Applicable Indoor Unit.....	3
3. DIMENSIONAL DATA	4
4. COOLING CAPACITY	5
5. HEATING CAPACITY	7
6. REFRIGERANT FLOW DIAGRAM	9
7. ELECTRICAL DATA	10
● Electrical Characteristics	10
● Electrical Wiring Diagram.....	11

1. OPERATING RANGE

CMH1822 / KMH0922 (×2)

Temperature	Indoor Air Intake Temp.	Outdoor Air Intake Temp.
Maximum	95°F DB / 71°F WB	115°F DB
Minimum	67°F DB / 57°F WB	67°F DB

2. SPECIFICATIONS

Unit Specifications

Model No.		Outdoor unit	CMH1822			
		Applicable indoor unit	KMH0922			
Performance	No. of indoor units		1 unit (Cooling)	1 unit (Heating)	2 units (Cooling)	2 units (Heating)
	Capacity	BTU/h	8,800 / 8,700	10,000 / 9,800	16,800 / 16,300	19,000 / 18,000
		kW	2.58 / 2.55	2.93 / 2.87	4.92 / 4.78	5.57 / 5.27
Electrical Rating	Phase, Frequency	Hz	Single, 60	Single, 60	Single, 60	Single, 60
	Voltage rating	V	230 / 208	230 / 208	230 / 208	230 / 208
	Available voltage range	V	187 to 253	187 to 253	187 to 253	187 to 253
	Running amperes	A	4.1 / 4.3	4.1 / 4.3	8.2 / 8.7	7.5 / 7.9
	Power input	W	900 / 870	900 / 870	1,820 / 1,780	1,640 / 1,590
	Power factor	%	95 / 97	95 / 97	95 / 97	95 / 97
	Starting amperes	A	27	27	27 × 2	27 × 2
	S. E. E. R. (H. S. P. F.)	BTU/Wh	10.0 / 10.0	(7.0 / 7.0)	10.0 / 10.0	(7.0 / 7.0)
Features	Fan speeds		1			
	Compressor ... number		Rotary ... 2			
	Refrigerant amount charged at shipment	lbs. (kg)	R-22: 2.34 (1.06) × 2			
	Refrigerant control		Capillary tube			
	Operation sound (Outdoor unit)	dB-A	54			
	Refrigerant tubing connections		Flare type			
	Max. allowable tubing length at shipment	ft. (m)	33 (10)			
	Limit of tubing length	ft. (m)	50 (15)			
	Limit of elevation difference between the 2 units	ft. (m)	23 (7)			
	Refrigerant tube o.d.	Narrow tube in. (mm)	1/4 (6.35)			
	Wide tube in. (mm)	3/8 (9.52)				
Refrigerant tube kit		Optional				
Dimensions & Weight	Height	in. (mm)	24-13/16 (630)			
	Width	in. (mm)	32-11/16 (830)			
	Depth	in. (mm)	12-13/32 (315)			
	Net weight	lbs. (kg)	134 (60.8)			
	Shipping volume	cu. ft. (cu. m)	10.3 (0.96)			
	Shipping weight (Approx.)	lbs. (kg)	140.8 (64)			

DATA SUBJECT TO CHANGE WITHOUT NOTICE.

Remarks: Rating conditions are:

- Cooling: Outside air temperature 95°F DB/75°F WB
Indoor unit entering air temperature 80°F DB/67°F WB
- Heating: Outside air temperature 47°F DB/43°F WB
Indoor unit entering air temperature 70°F DB

Applicable Indoor Unit

Model No.		KMH0922			
Type		Wall-mounted			
Performance	Capacity	BTU/h	Cooling 8,800 / 8,700	Heating 10,000 / 9,800	
		kW	2.58 / 2.55	2.93 / 2.87	
	Air circulation (High)		cu. ft./min. 220 / 210		
	Moisture removal (High)		pints/h 2.2		
Electrical Rating	Phase, Frequency		Hz Single, 60		
	Voltage rating		V 230 / 208		
	Available voltage range		V 187 to 253		
	Heat element		kW – HSPF — 1.0 / 0.82 – 6.6 / 6.6		
Features	Controls		Microprocessor		
	Control unit		Remote control unit		
	Temperature control		IC thermostat		
	Timer		ON/OFF 12-hours		
	Fan speeds		3		
	Air deflector		Horizontal / Vertical Manual / Manual		
	Air filter		Washable, easy access		
	Operation sound		Hi / Me / Lo	dB-A 40 / 35 / 30	
	Refrigerant tubing connections		Flare type		
	Refrigerant tube o.d.	Narrow tube	in. (mm)	1/4 (6.35)	
		Wide tube	in. (mm)	3/8 (9.52)	
	Refrigerant tube kit		Optional		
Accessories		Mounting bracket			
Dimensions & Weight	Height		in. (mm) 13-19/32 (345)		
	Width		in. (mm) 31-1/2 (800)		
	Depth		in. (mm) 7-3/32 (180)		
	Net weight		lbs. (kg) 24 (11)		
	Shipping volume		cu. ft. (cu. m) 3.3 (0.093)		
	Shipping weight		lbs. (kg) 29 (13)		

DATA SUBJECT TO CHANGE WITHOUT NOTICE.

Remarks: Rating conditions are:

- Cooling: Outside air temperature 95°F DB/75°F WB
Indoor unit entering air temperature 80°F DB/67°F WB
- Heating: Outside air temperature 47°F DB/43°F WB
Indoor unit entering air temperature 70°F WB

3. DIMENSIONAL DATA

Outdoor Unit: CMH1822

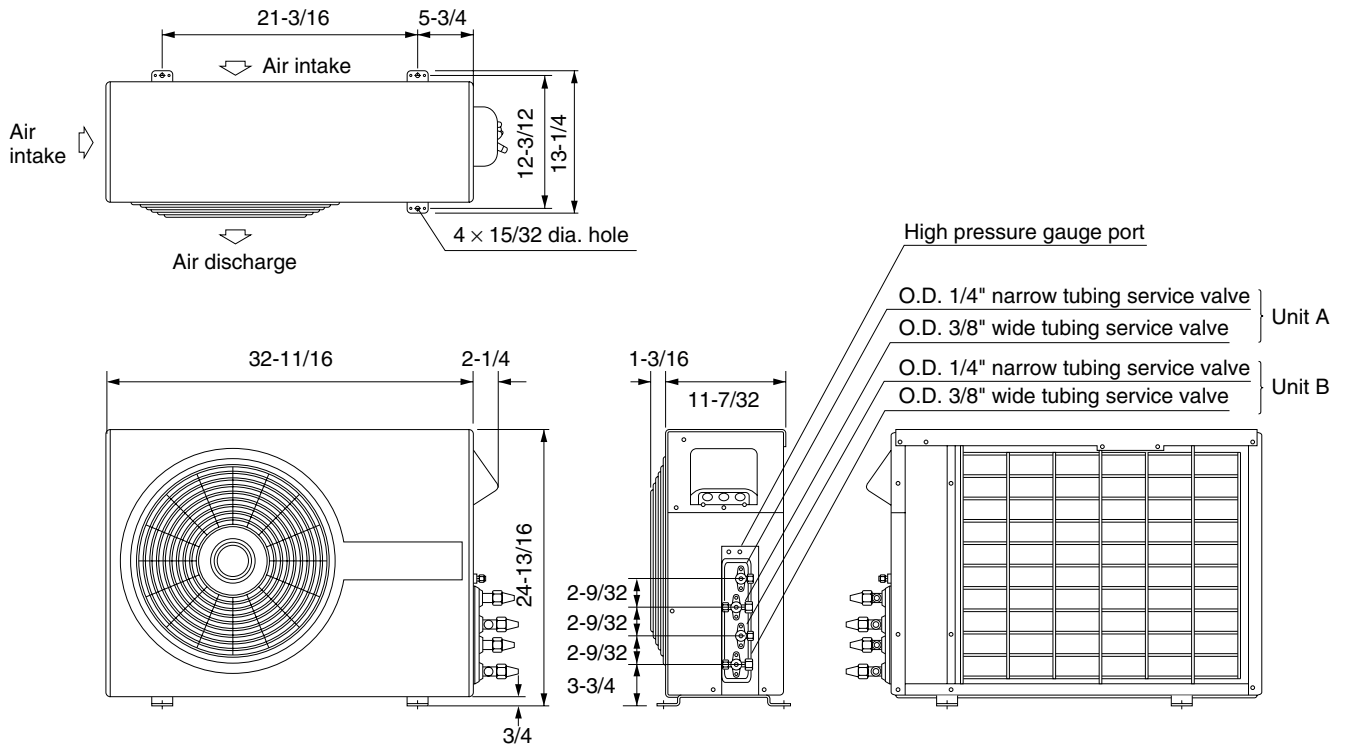

Indoor Unit: KMH0922

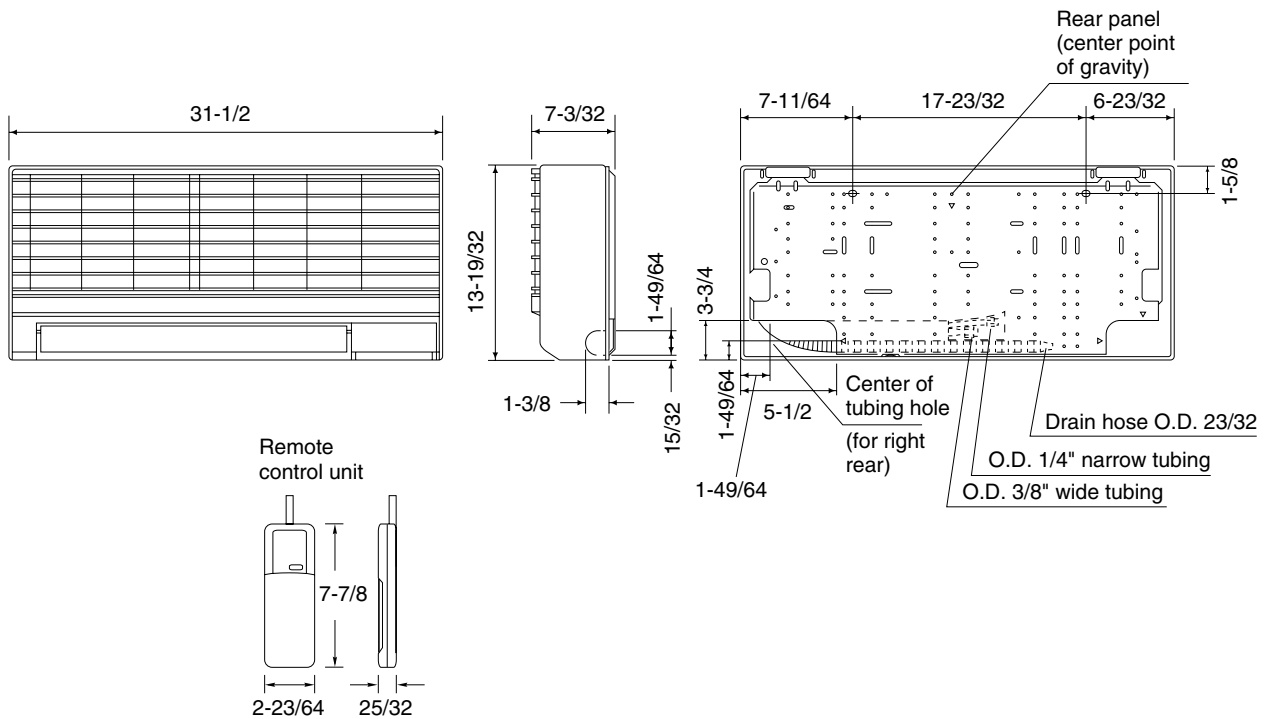

4. COOLING CAPACITY

230V

CMH1822 / KMH0922 (×1)

Rating Capacity: 8,800 BTU/H			Air Flow Rate: 220 CFM				
Evaporator		Condenser					
Ent. Temp. °F/(°C)		Ambient Temp. °F/(°C)					
WB	DB		75 (23.9)	85 (29.4)	95 (35.0)	105 (40.6)	115 (46.1)
59 (15.0)		TC	8,710	8,320	7,920	7,470	6,860
		kW	0.62	0.67	0.73	0.79	0.87
	72 (22.2)	SHC	6,200	5,990	5,790	5,560	5,260
	76 (24.4)	SHC	6,940	6,740	6,530	6,300	6,000
	80 (26.7)	SHC	7,720	7,510	7,310	7,080	6,780
	84 (28.9)	SHC	8,460	8,250	7,920	7,470	6,860
	88 (31.1)	SHC	8,710	8,320	7,920	7,470	6,860
63 (17.2)		TC	9,010	8,730	8,390	7,930	7,300
		kW	0.62	0.68	0.74	0.81	0.89
	72 (22.2)	SHC	5,260	5,120	4,960	4,740	4,460
	76 (24.4)	SHC	6,000	5,860	5,700	5,490	5,200
	80 (26.7)	SHC	6,780	6,640	6,480	6,260	5,970
	84 (28.9)	SHC	7,520	7,380	7,220	7,000	6,720
	88 (31.1)	SHC	8,260	8,120	7,960	7,740	7,300
67 (19.4)		TC	9,260	9,110	*8,800	8,320	7,740
		kW	0.63	0.69	0.75	0.82	0.91
	72 (22.2)	SHC	4,280	4,220	4,080	3,870	3,630
	76 (24.4)	SHC	5,020	4,960	4,820	4,610	4,370
	80 (26.7)	SHC	5,800	5,730	5,600	5,390	5,150
	84 (28.9)	SHC	6,540	6,470	6,340	6,130	5,890
	88 (31.1)	SHC	7,280	7,220	7,080	6,870	6,630
71 (21.7)		TC	9,550	9,390	9,150	8,740	8,230
		kW	0.63	0.69	0.76	0.84	0.93
	72 (22.2)	SHC	3,280	3,220	3,120	2,960	2,760
	76 (24.4)	SHC	4,020	3,960	3,860	3,700	3,510
	80 (26.7)	SHC	4,800	4,730	4,640	4,480	4,280
	84 (28.9)	SHC	5,540	5,470	5,380	5,220	5,020
	88 (31.1)	SHC	6,280	6,220	6,120	5,960	5,760
75 (23.9)		TC	9,730	9,630	9,420	9,080	8,710
		kW	0.65	0.71	0.77	0.86	0.95
	76 (24.4)	SHC	3,020	2,980	2,910	2,790	2,660
	80 (26.7)	SHC	3,790	3,760	3,680	3,560	3,430
	84 (28.9)	SHC	4,540	4,500	4,420	4,300	4,180
	88 (31.1)	SHC	5,280	5,240	5,160	5,050	4,920

TC: Total Cooling Capacity (BTU/H)

SHC: Sensible Heat Capacity (BTU/H)

kW: Compressor Input (kW)

Remarks: Rating conditions (* mark) are: Outside ambient temperature 95°F DB

Indoor unit entering air temperature 80°F DB/67°F WB

208V

CMH1822 / KMH0922 (×1)

Rating Capacity: 8,700 BTU/H			Air Flow Rate: 210 CFM				
Evaporator		Condenser					
Ent. Temp. °F/(°C)		Ambient Temp. °F/(°C)					
WB	DB		75 (23.9)	85 (29.4)	95 (35.0)	105 (40.6)	115 (46.1)
59 (15.0)		TC	8,610	8,220	7,830	7,390	6,790
		kW	0.61	0.66	0.72	0.78	0.86
	72 (22.2)	SHC	6,090	5,880	5,680	5,450	5,150
	76 (24.4)	SHC	6,800	6,590	6,390	6,160	5,860
	80 (26.7)	SHC	7,550	7,340	7,130	6,910	6,610
	84 (28.9)	SHC	8,260	8,050	7,830	7,390	6,790
	88 (31.1)	SHC	8,610	8,220	7,830	7,390	6,790
63 (17.2)		TC	8,910	8,630	8,290	7,840	7,220
		kW	0.61	0.67	0.73	0.80	0.88
	72 (22.2)	SHC	5,180	5,040	4,870	4,660	4,370
	76 (24.4)	SHC	5,890	5,750	5,590	5,370	5,090
	80 (26.7)	SHC	6,630	6,500	6,330	6,120	5,830
	84 (28.9)	SHC	7,350	7,210	7,050	6,830	6,550
	88 (31.1)	SHC	8,060	7,930	7,760	7,550	7,220
67 (19.4)		TC	9,150	9,000	*8,700	8,220	7,660
		kW	0.62	0.68	0.74	0.81	0.90
	72 (22.2)	SHC	4,230	4,160	4,030	3,820	3,580
	76 (24.4)	SHC	4,940	4,870	4,740	4,530	4,290
	80 (26.7)	SHC	5,690	5,620	5,490	5,280	5,040
	84 (28.9)	SHC	6,400	6,330	6,200	5,990	5,750
	88 (31.1)	SHC	7,110	7,050	6,910	6,700	6,460
71 (21.7)		TC	9,440	9,280	9,050	8,640	8,130
		kW	0.62	0.68	0.75	0.83	0.91
	72 (22.2)	SHC	3,250	3,190	3,100	2,940	2,740
	76 (24.4)	SHC	3,970	3,900	3,810	3,650	3,450
	80 (26.7)	SHC	4,710	4,650	4,560	4,400	4,200
	84 (28.9)	SHC	5,430	5,360	5,270	5,110	4,910
	88 (31.1)	SHC	6,140	6,080	5,980	5,820	5,630
75 (23.9)		TC	9,620	9,520	9,310	8,980	8,610
		kW	0.64	0.70	0.76	0.85	0.94
	76 (24.4)	SHC	3,000	2,960	2,880	2,760	2,640
	80 (26.7)	SHC	3,740	3,700	3,630	3,510	3,380
	84 (28.9)	SHC	4,450	4,420	4,340	4,220	4,090
	88 (31.1)	SHC	5,170	5,130	5,050	4,940	4,810

TC: Total Cooling Capacity (BTU/H)

SHC: Sensible Heat Capacity (BTU/H)

kW: Compressor Input (kW)

Remarks: Rating conditions (* mark) are: Outside ambient temperature 95°F DB

Indoor unit entering air temperature 80°F DB/67°F WB

5. HEATING CAPACITY

1 Phase 60Hz 230V Model Name: CMH1822 / KMH0922 (x1)

Indoor Entering Air Temperature 70°F

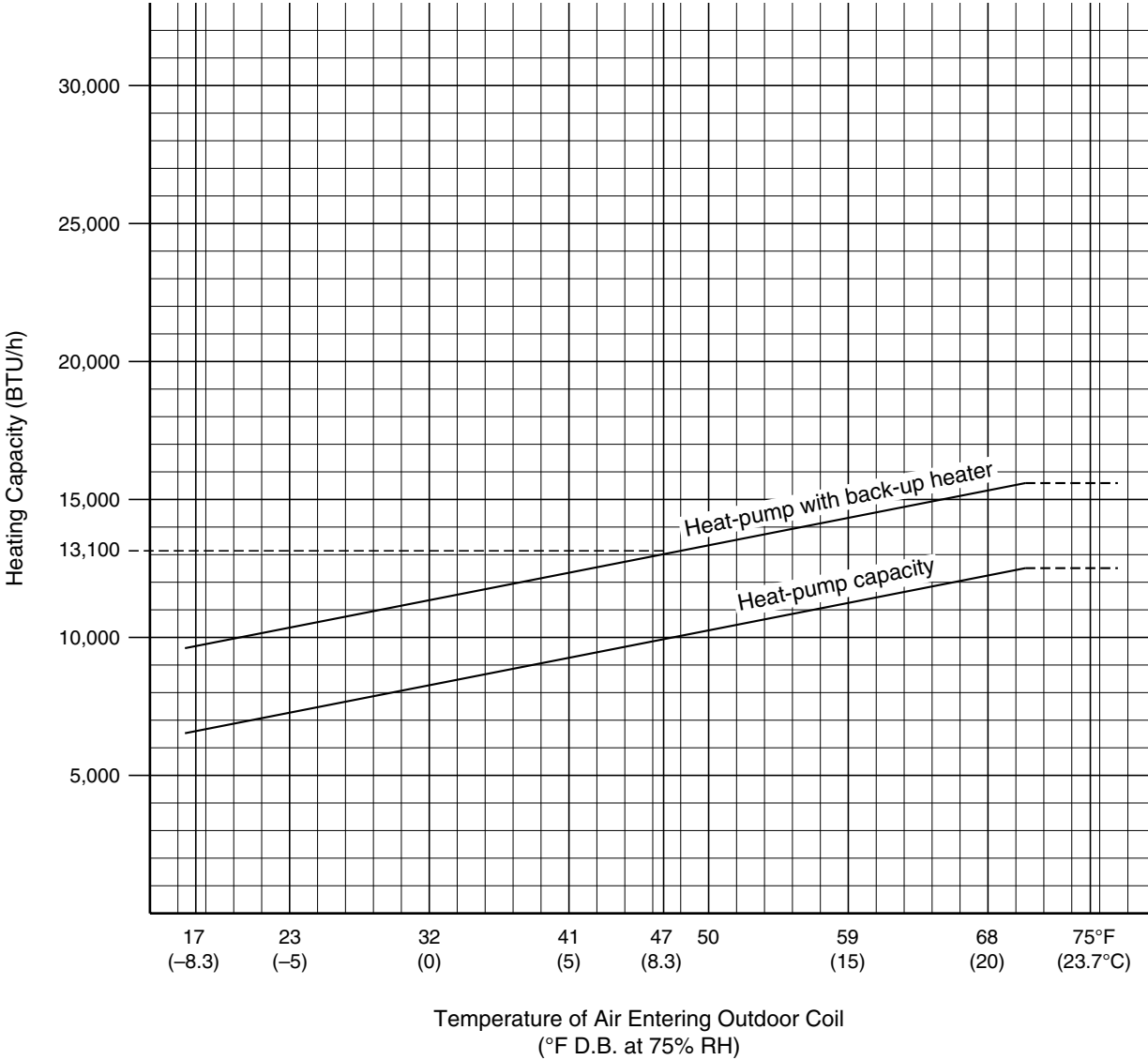

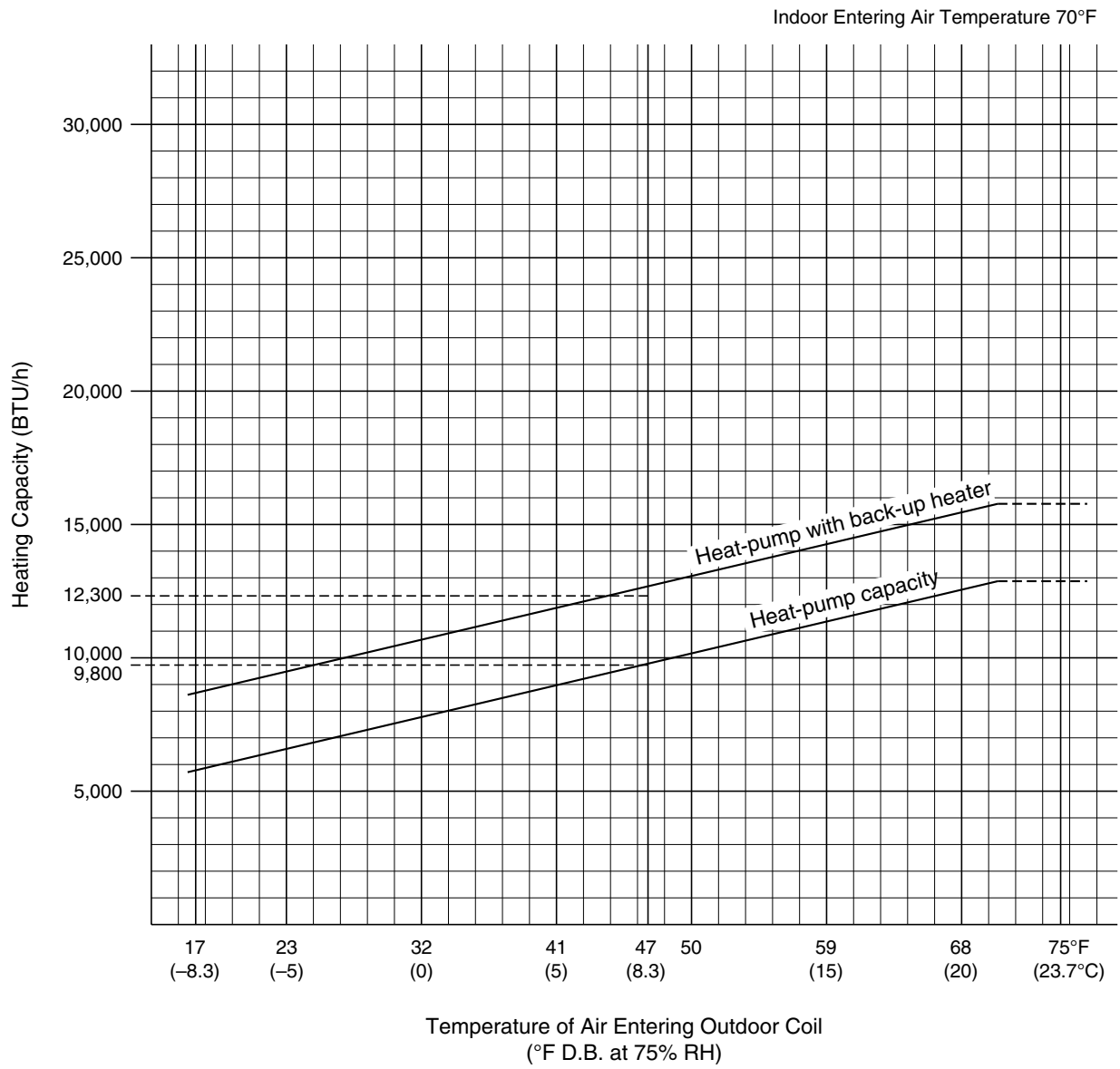

6. REFRIGERANT FLOW DIAGRAM

Cooling Cycle

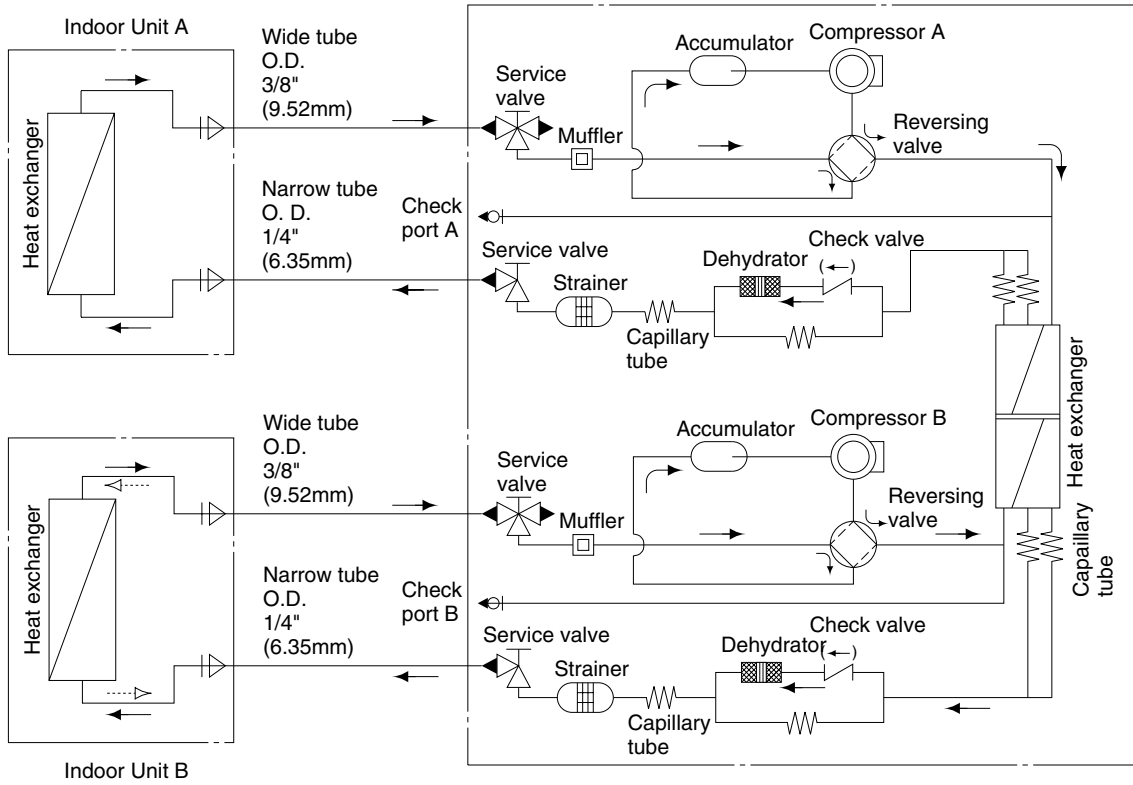

Heating Cycle

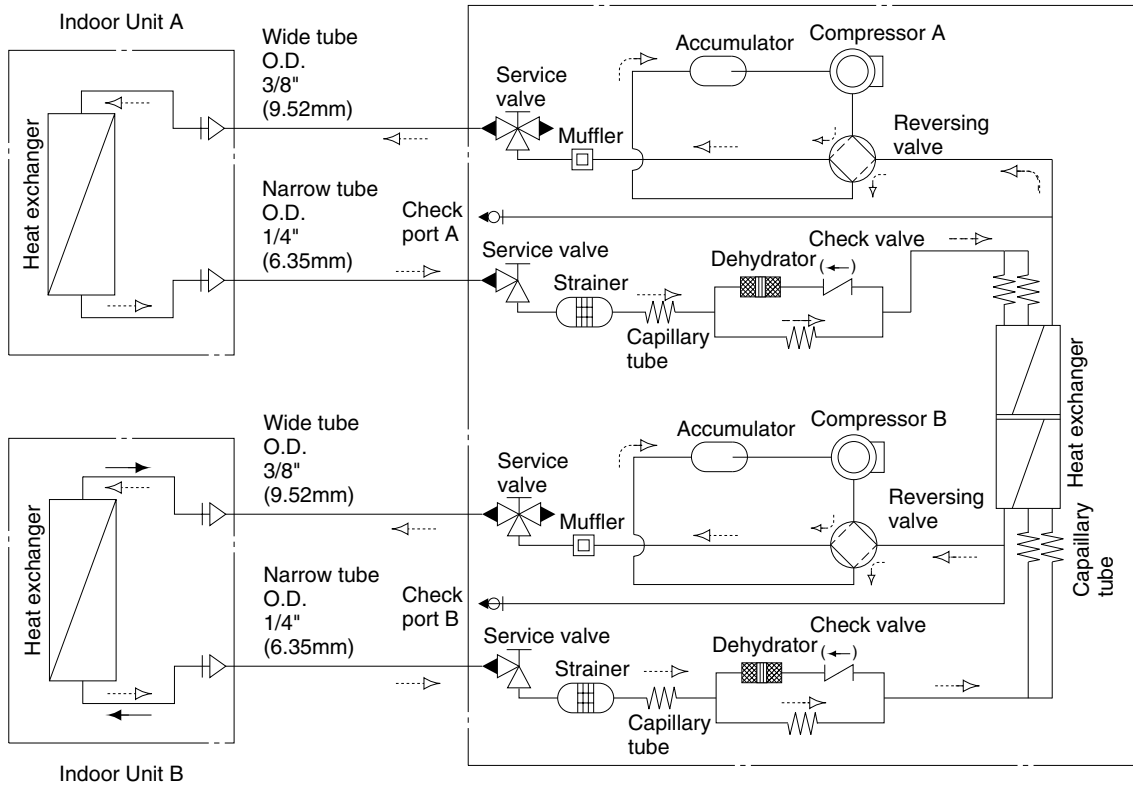

7. ELECTRICAL DATA

● Electrical Characteristics

CMH1822 / KMH0922 (×1)

Performance at 230/208V – 1ϕ – 60Hz			Indoor Unit		Outdoor Unit		Complete Unit	
			Fan Motor	Max. Heat	Fan Motor	Compressor	Heat-pump	Max. Heat
Cooling	Rating Conditions	A	0.15 / 0.14	—	0.52 / 0.52	3.43 / 3.64	4.1 / 4.3	—
		W	34 / 29	—	116 / 104	750 / 737	900 / 870	—
Heating	Rating Conditions	A	0.15 / 0.14	4.35 / 3.93	0.52 / 0.52	3.43 / 3.64	4.1 / 4.3	8.45 / 8.23
		W	34 / 29	1,000 / 818	116 / 104	750 / 737	900 / 870	—
Locked-Rotor Amperes		A	0.19 / 0.18	—	0.71 / 0.64	27	—	—

Remarks: Rating conditions are:

Cooling: Outside air temperature 95°F DB/75°F WB

Indoor unit entering air temperature 80°F DB/67°F WB

Heating: Outside air temperature 47°F DB/43°F WB

Indoor unit entering air temperature 70°F WB

CMH1822 / KMH0922 (×2)

Performance at 230/208V – 1ϕ – 60Hz			Indoor Unit		Outdoor Unit		Complete Unit	
			Fan Motor	Max. Heat	Fan Motor	Compressor	Heat-pump	Max. Heat
Cooling	Rating Conditions	A	0.30 / 0.28	—	0.52 / 0.52	7.38 / 7.90	8.2 / 8.7	—
		W	68 / 58	—	116 / 104	1,636 / 1,618	1,820 / 1,780	—
Heating	Rating Conditions	A	0.30 / 0.28	8.70 / 7.86	0.52 / 0.52	6.68 / 7.10	7.5 / 7.9	16.2 / 15.76
		W	68 / 58	2,000 / 1,636	116 / 104	1,456 / 1,428	1,640 / 1,590	3,640 / 3,226
Locked-Rotor Amperes		A	0.19 × 2 / 0.18 × 2	—	0.71 / 0.64	27 × 2	—	—

Remarks: Rating conditions are:

Cooling: Outside air temperature 95°F DB/75°F WB

Indoor unit entering air temperature 80°F DB/67°F WB

Heating: Outside air temperature 47°F DB/43°F WB

Indoor unit entering air temperature 70°F WB

● Electrical Wiring Diagram

Outdoor Unit: CMH1822

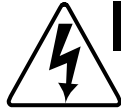

WARNING:

To avoid electrical shock hazard, be sure to disconnect power before checking, servicing and/or cleaning any electrical parts.

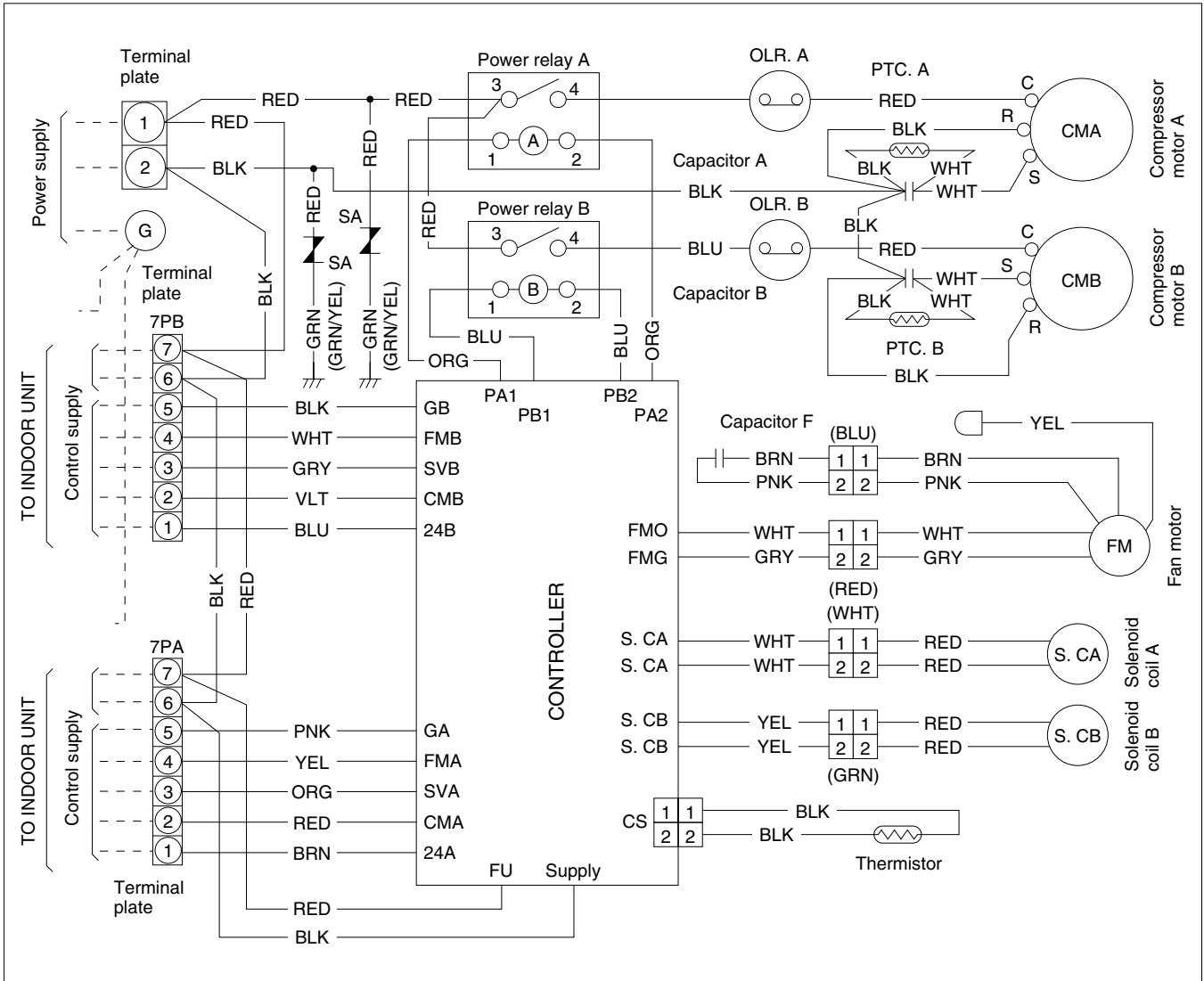

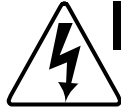

WARNING:

To avoid electrical shock hazard, be sure to disconnect power before checking, servicing and/or cleaning any electrical parts.

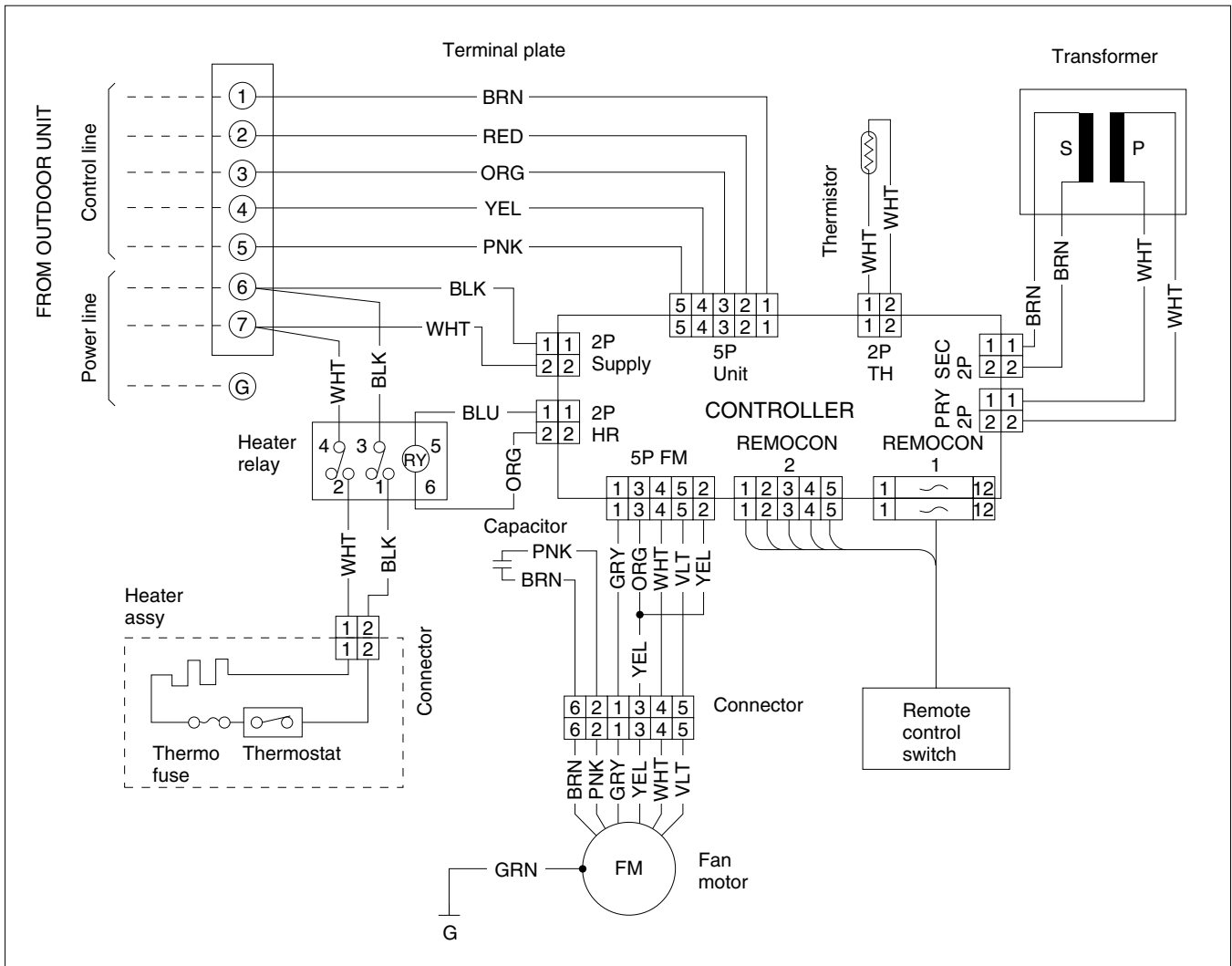

For parts or service contact



SFS Corporation: 1200 West Artesia Blvd., Compton, California 90220

In Canada SANYO Canada Inc.: Toronto, Ont. M4H 1M6

H407/12M

Printed in U.S.A.
WM-700700