

---

# INSTALLATION INSTRUCTIONS

---

## Horizontal And Vertical Table Stands and Accessories

### Model: KTP-Series

The KTP-Series is a free standing, pole mount solution for multiple displays.



---

#### BEFORE YOU BEGIN

##### **⚠ CAUTION!**

To prevent damage to the Kit, which could affect or void the Factory warranty, and to the equipment that will be attached to it, thoroughly study all instructions and illustrations before you begin the installation.

- If you have any questions about this installation, contact Chief Manufacturing at 1-800-582-6480.

Chief® and Centris™ are trademarks of Milestone AV Technologies. All rights reserved.

**TOOLS REQUIRED FOR INSTALLATION**

- Phillips Head Screw Driver
- 3/4" Wrench
- 3/32" Hex Key (provided)
- 5/32" Hex Key (provided)
- 7/32" Hex Key (provided)

**WEIGHT CAPACITIES**

**KTP-220 / KTP-225:** 35 lbs. per monitor  
**KTP-230:** 35 lbs. per monitor  
**KTP-320:** 30 lbs. per monitor  
**KTP-440 / KTP-445:** 20 lbs. per monitor

**PARTS**

Carefully inspect components for shipping damage . If damage is apparent, call your carrier claims agent and do not continue with installation until the carrier has reviewed the damage.(see Figure 1)

**Table 1: Parts**

ITEM	DESCRIPTION	QUANTITY By MODEL					
		220	225	230	320	440	445
10	CENTRIS HEAD ASSEMBLY, Pole Mount			2			
20	ARRAY ASSEMBLY, Dual, 27"	1				2	
	ARRAY ASSEMBLY, Dual, 34"		1				2
30	ARRAY ASSEMBLY, Triple				1		
40	BASE, Freestand	1	1	1	1	1	1
50	POLE, Freestand, 14"	1	1		1		
60	POLE, Freestand, 28"			1		1	1
70*	POLE, Freestand, 42"						
80	SHEATH, Cable Management, 8"	1	1	2	1	2	2
90	SCREW, Freestand Pole Mounting, 3/8-16 x 1" (FHCS)	1	1	1	1	1	1
100*	SCREW, Cable Management Grommet Mounting, 3/8-16 x 6"						
110*	GROMMET, Cable Management						
120	KEY, Hex, 5/32"	1	1	1	1	1	1
130	KEY, Hex, 3/16"			1			
140	KEY, Hex, 7/32"	1	1	1	1	1	1
160**	SCREW, Phillips Pan Head, M4 x 12mm	8	8	8	12	16	16
170**	SCREW, Phillips Pan Head, M4 x 20mm	8	8	8	12	16	16
180**	SCREW, Phillips Pan Head, M4 x 30mm	8	8	8	12	16	16
190**	SPACER, Nylon, 3/8" (used with item 170)	8	8	8	12	16	16
200**	SPACER, Nylon, 3/4" (used with item 180)	8	8	8	12	16	16
210	CLAMP, Front, Pole Mount			2			
220	CLAMP, Rear, Pole Mount			2			
230	SCREW, Button Head Cap,			6			
240	CLAMP, Back, Array mounting	1	1		1	2	2
250	WASHER, Flat, 1/4"	2	2		2	4	4
260	SCREW, Button Head Cap, 1/4-20 x 3/4"	2	2		2	4	4

\* Indicates an available optional accessory not included with above models. For additional information pertaining to available accessories contact a Chief Customer Service representative at 1-800-582-6480 or visit us at [www.chiefmfg.com](http://www.chiefmfg.com).

\*\* Quantity varies depending upon the number of displays being installed.

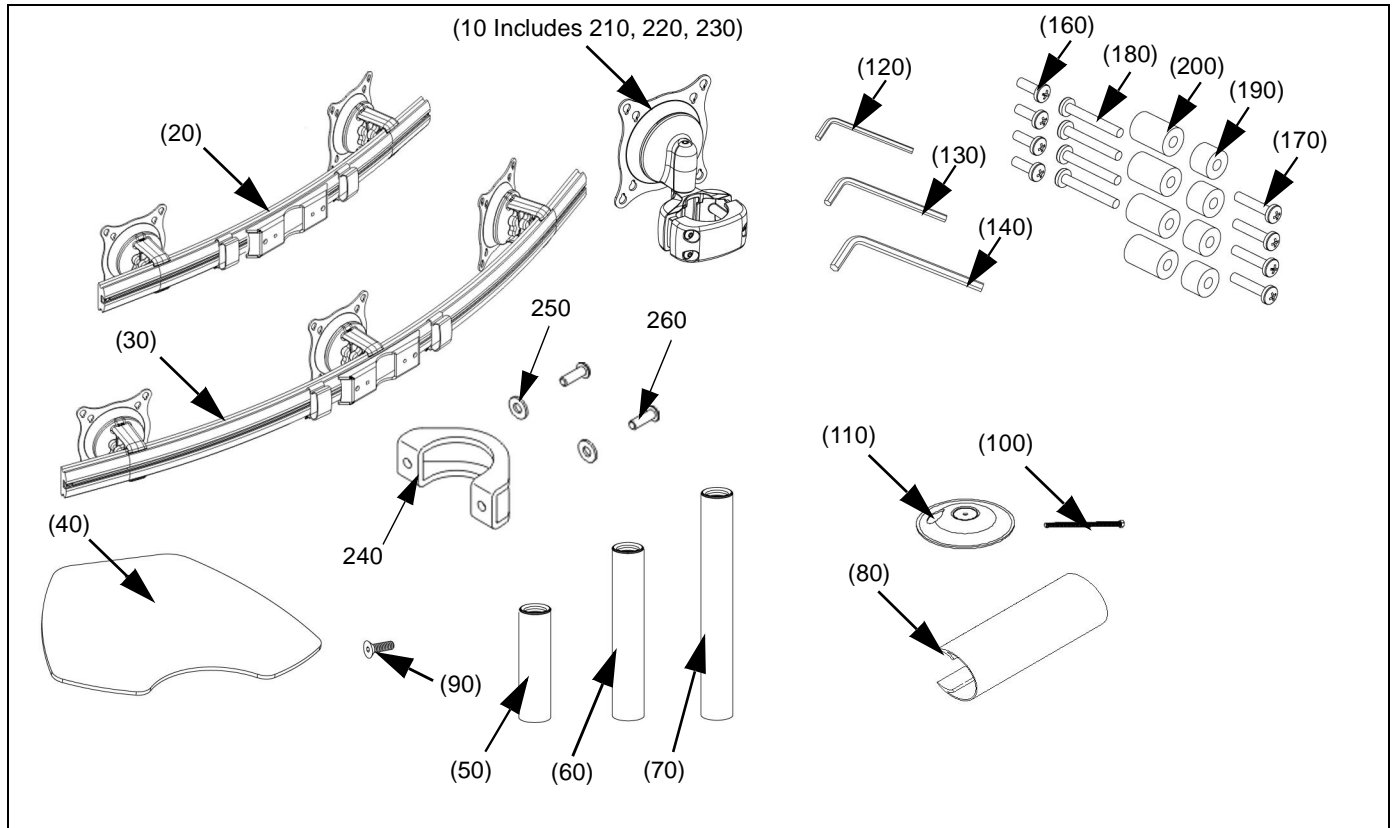


Figure 1: Parts

**ASSEMBLY AND INSTALLATION**

**Mount Assembly**

**KTP-230 Assembly**

To assemble the KTP-230:

1. Assemble pole (60) to base (40) using one 3/8-16 x 1" FHCS (90). (see Figure 2)

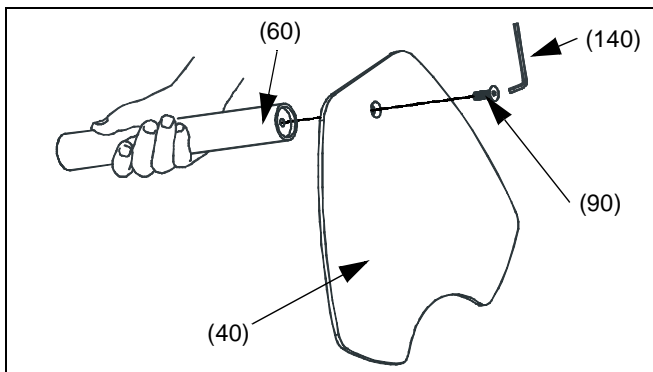


Figure 2: Assemble Pole to Base

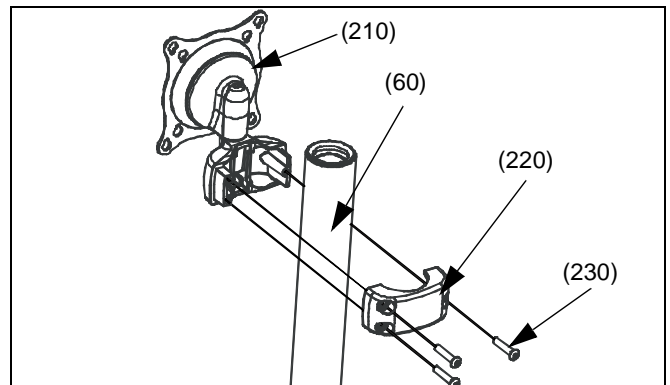
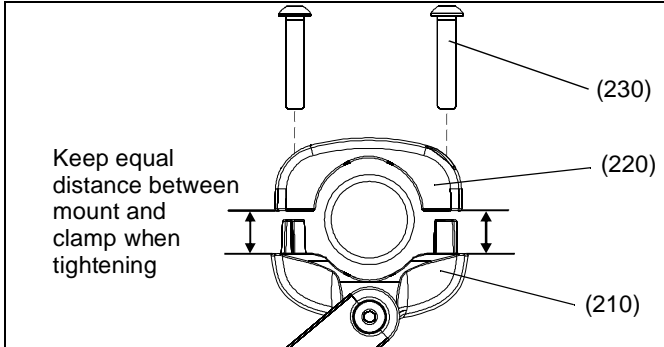


Figure 3: Mount Centris Head with Pole Clamp

2. Place front pole clamp, with Centris Head, (210) against pole in approximate mounting location.
3. Place three BHCS (230) into rear pole clamp (220) and place against pole aligning with front pole clamp (210). (see Figure 3)

**NOTE:** Equally tighten screws (230) against front pole mount (210) and rear (220) pole clamps. (see Figure 4)



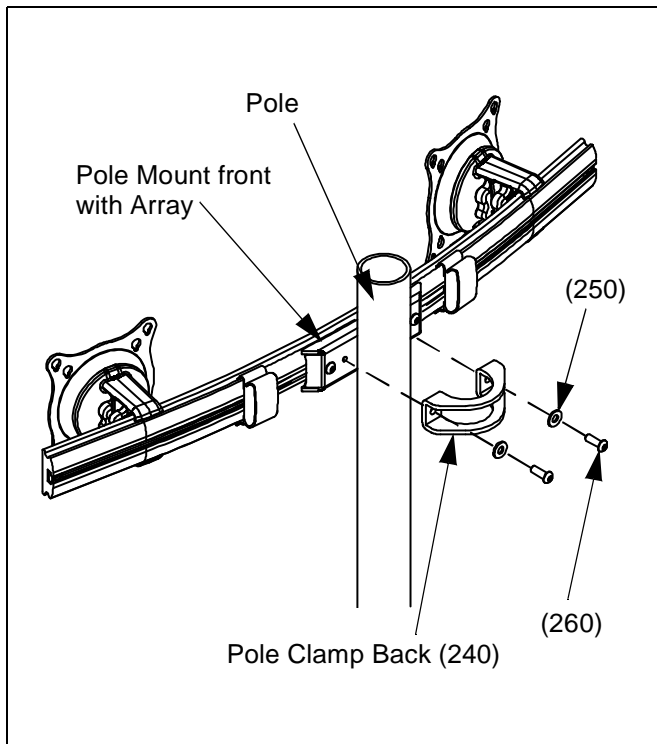
**Figure 4:**

4. Secure rear pole clamp (220) to front pole mount (210) and pole by tightening three BHCS (230) using 5/32" hex key (120). (see Figure 3)

**KTP-220, 320, and 440 Assembly**

To assemble the KTP-220, 320, and 440:

1. Assemble pole (50) to base (40) using one 3/8-16 x 1" FHCS (90). (see Figure 2)
2. Assemble pole clamp back (240) to pole mount front using two FW (250) and two BHCS (260) using a 5/32" hex key. (see Figure 5)
3. Secure pole mount back (240) to pole mount front and pole by tightening two BHCS (260) using a 5/32" hex key.



**Figure 5: Assemble Array Rail to Pole**

**Display Installation**

**Attach Centris Head to Flush Mount Display**

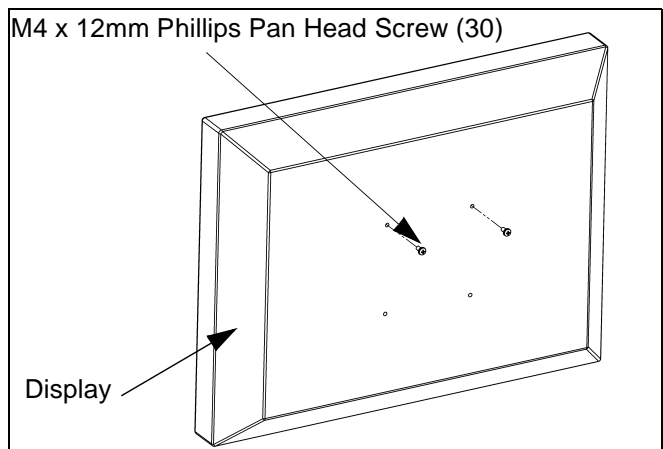
**⚠ CAUTION!**

**CAUTION:** If display uses a screw size other than those included in the kit, DO NOT use the screws provided. Using the wrong screws could result in damage to your monitor.

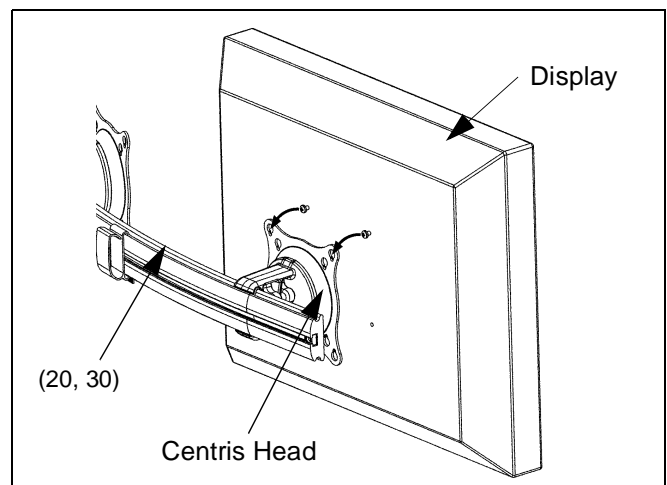
1. Install two M4 x 12mm Phillips pan head screws (160) into two upper mounting holes in display back. (see Figure 6)

**NOTE:** DO NOT fully tighten at this time.

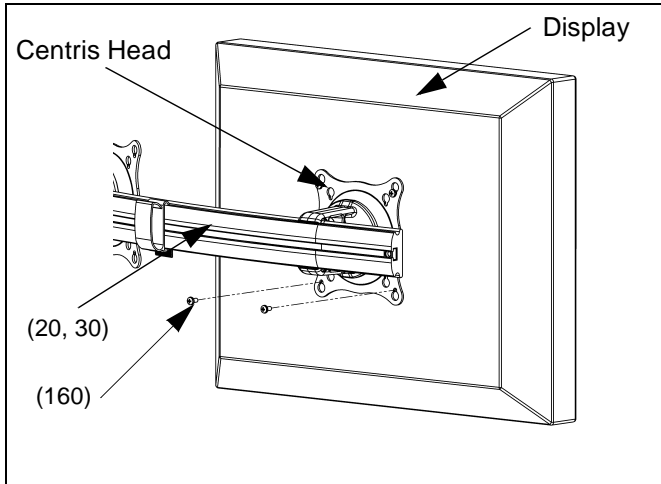
2. Hang display on Centris head. (see Figure 7)
3. Install bottom two M4 x 12mm Phillips pan head screws (160) through Centris head mounting holes and into lower mounting holes in display back.
4. Tighten ALL four M4 x 12mm Phillips pan head screws (160). (see Figure 8)



**Figure 6: Prepare Display**



**Figure 7: Hang Display**

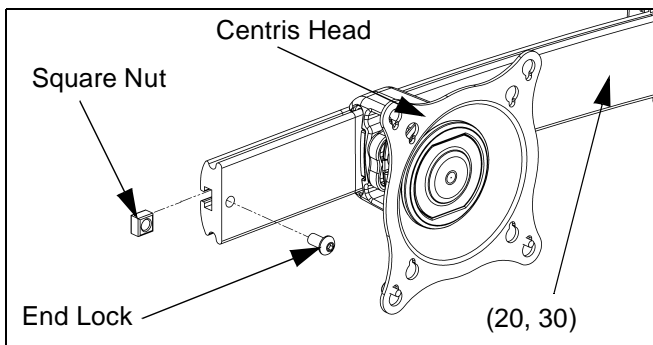


**Figure 8: Secure Display to Centris Bracket**

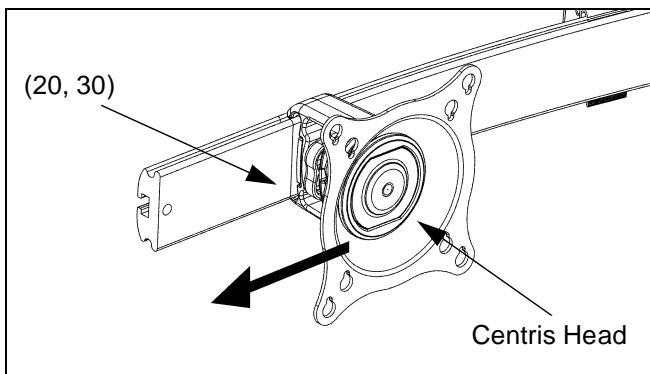
**Attach Centris Head to Recessed Mount Display**

**NOTE:** Refer to Table 3 to select the applicable screw and spacer combination.

1. Uninstall end lock using the 5/32" hex key (120). (see Figure 9)
2. Remove Centris head from array rail (20, 30).

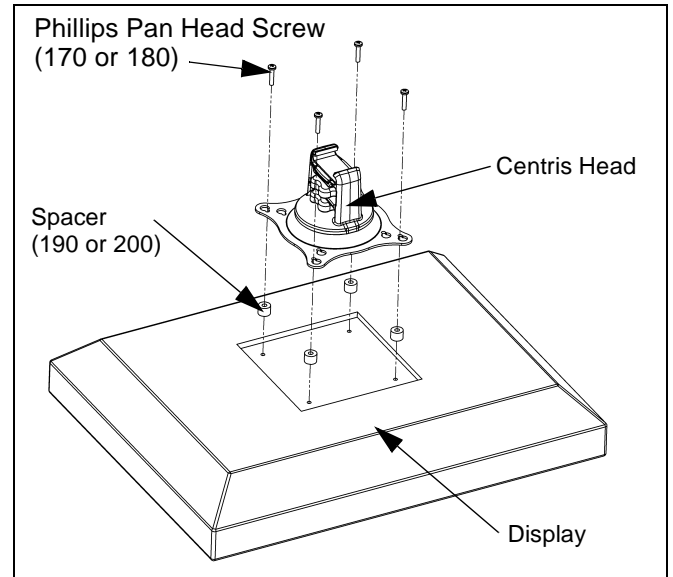


**Figure 9: Remove End Lock(s)**



**Figure 10: Slide Centris Bracket off Array Rail**

3. Place display face down on a clean dry surface.
4. Place four 3/8" or 3/4" nylon spacers (190 or 200) over four mounting holes in display back (see Figure 11).
5. Align Centris head mounting holes with four nylon spacers (see Figure 11).
6. Secure Centris head to display using four M4 x 20mm Phillips pan head screws (170), or four M4 x 30mm Phillips pan head screws (180) (see Figure 11).

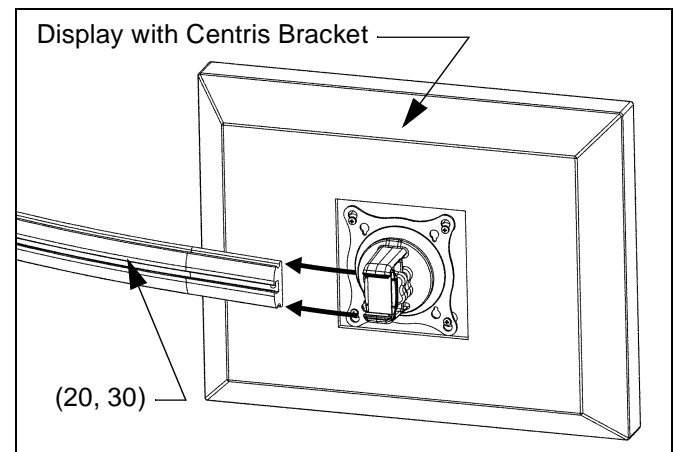


**Figure 11: Mount Centris Bracket to Display**

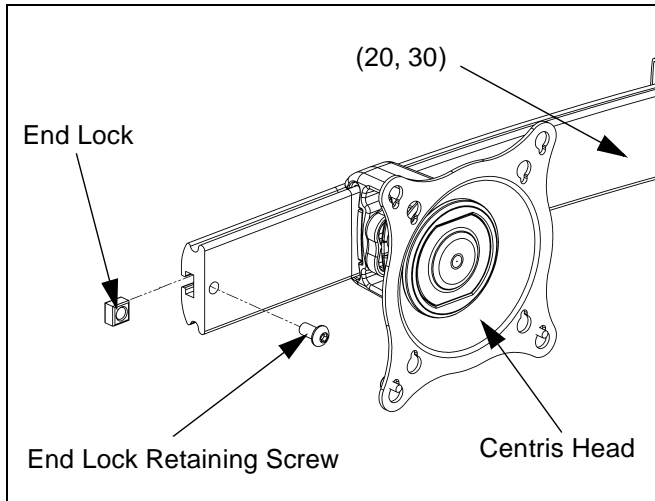
7. Slide display with Centris bracket onto array rail (20, 30) (see Figure 12).

**NOTE:** Repeat previous steps for each additional display.

8. Reinstall end locks into mounting rail using the 5/32" hex key (120) (see Figure 13).



**Figure 12: Mount Display with Centris Bracket to Array Rail**



**Figure 13: Reinstall End Lock(s)**

**ADJUSTMENTS**

**Display Adjustment**

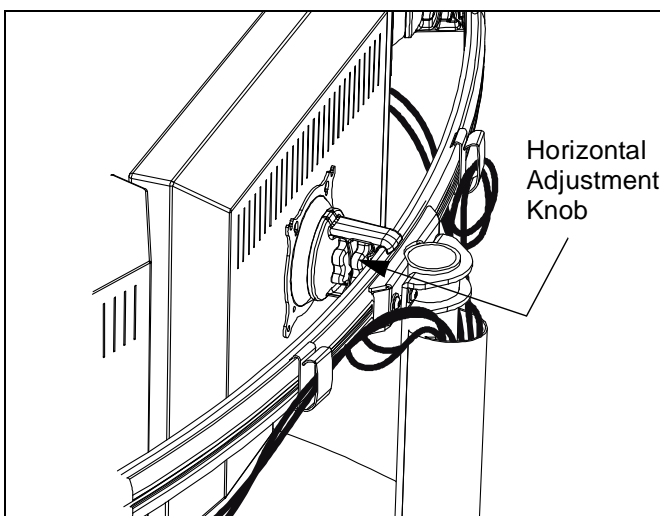
The KTP Series mount allows horizontal, pitch, and rotational adjustment of each display.

The KTP Series mount also allows a full 360 deg. of display rotation with a maximum pitch range of 15° up and 15° down.

**Display Horizontal Position Adjustment**

To adjust display horizontal position:

1. Loosen Centris bracket rear adjustment knob (see Figure 14).
2. Slide Centris bracket with display left or right until properly positioned on array rail.
3. Tighten Centris bracket rear adjustment knob.

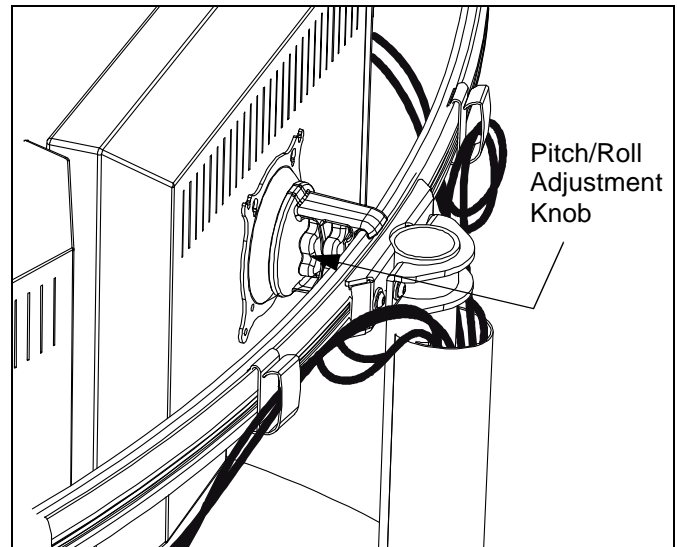


**Figure 14: Display Horizontal Adjustment**

**Display Pitch and Roll Adjustment**

To adjust display pitch or roll position:

1. Loosen Centris bracket front adjustment knob. (see Figure 15)
2. Tilt display up or down, or adjust display roll left or right until properly positioned.
3. Tighten Centris bracket front adjustment knob.



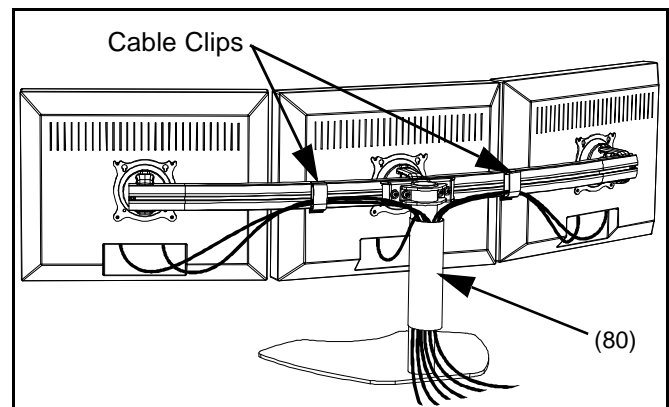
**Figure 15: Display Pitch and Roll Adjustment**

**CABLE MANAGEMENT**

The KTP Series mount includes cable management features used to properly route and secure display cables.

To use the cable management features:

1. Connect cables to display.
2. Route cables through cable clips on array rail.
3. Route cables down pole and away from mount and secure to pole using sheath (80).



**Figure 16: Cable Management**



