FCC Warning

This equipment has been tested and found to comply with the limits for a Class A digital device, pursuant to part 15 of the FCC Rules. These limits are designed to provide reasonable protection against harmful interference when the equipment is operated in a commercial environment. This equipment generates, uses, and can radiate radio frequency energy and, if not installed and used in accordance with the instruction manual, may cause harmful interference to radio communications. Operation of this equipment in a residential area is likely to cause harmful interference in which case the user will be required to correct the interference at his own expense.

DOC (Canada)

This Class A digital apparatus meets all requirements of the Canadian Interference-Causing Equipment Regulations.
Cet appareil numérique de la classe A respecte toutes les exigences du Règlement sur le matériel brouilleur du Canada.

Safety Certifications

UL, CUL, TÜV, NOM

EN 55022 Warning

This product is intended for use in a commercial, industrial, or educational environment. It is not intended for residential use.

This is a Class A product. In a domestic environment it may cause radio interference, in which case the user may be required to take adequate measures. The typical use is in a conference room, meeting room or auditorium.

Wenn das Produkt Boxlight 9000 in Deutschland verkauft wird, muss es Umwelt geschuetzt sein. (Klasse B) Dieses Product muss mit dem Bundesamt fuer Post und Telekommunikation registriert sein. (BAPT)

Trademarks

Apple, Macintosh, and PowerBook are trademarks or registered trademarks of Apple Computer, Inc. IBM and PS/2 are trademarks or registered trademarks of International Business Machines, Inc. MicroSaver and Kensington are trademarks or registered trademarks of Kensington Microware Limited. Microsoft, PowerPoint, and Windows are trademarks or registered trademarks of Microsoft Corporation. CablePro is a trademark or registered trademark of Boxlight Corporation.

Declaration of Conformity

Manufacturer: Boxlight Corporation

19332 Powder Hill Place, Poulsbo, Washington USA

We declare under our sole responsibility that the Boxlight 9000 Projector conforms to the following directives and norms:

Directive 89/336/EEC, Amended by 93/68/EEC

EMI: EN 55022 (1992) Class A

EMC: EN 50082-1 (1992)

IEC 801-2, IEC 801-3, IEC 801-4

Directive 73/23/EEC, Amended by 93/68/EEC

Safety: EN 60950: 1992 + A1 + A2 + A3: 1995

March, 1998



TABLE OF CONTENTS

Safety Summary	iii
Introduction	I
Image Resolution	1
Compatibility	1
Unpacking the Projector	1
Usage Guidelines	4
If You Need Assistance	4
Warranty	4
Setting up the Projector	5
Connecting an IBM-Compatible Computer Using the CablePro Lite Cable	11
Connecting a Macintosh Computer Using the CablePro Lite Cable	12
Connecting a Computer Using a VESA cable	13
Connecting a Computer using BNC cables	13
Connecting a Video Player	14
Connecting an External Speaker	15
Connecting the Remote Control Cable	16
Connecting a Computer with an RS-232 Cable	16
Powering up the Projector and Adjusting the Image	16
Turning Off the Projector	17
Using the Projector	19
Basic Image Adjustment	19
Adjusting the Projector	20
Using the Remote Control	21
Using the Remote and Keypad Buttons	22
Using the On-Screen Menus	25
Display Menu Functions	27
Audio Menu Functions	29
Image Menu Functions	31
Controls Menu Functions	33

Maintenance and Troubleshooting	35
Cleaning the Lens	35
Cleaning the Fan Intake Filter	35
Replacing the Projection Lamp	37
Replacing the Batteries in the Remote Control	39
Using the Kensington Lock	39
Troubleshooting	40
Solutions to Common Problems	40
Appendix	45
Specifications	45
Accessories	47
Portable and Laptop Activation Chart	49
Using Video Mirroring with a PowerBook Computer	53
Projected Image Size for Optional Lenses	54
Connection Pin Assignments	55
RS232 Terminal Specifications	57
Index	61

SAFETY SUMMARY

Please read these instructions carefully before using your projector. Failure to comply with them could result in fire, electrical shock, personal injury or damage to equipment.

These graphics are used throughout this manual to draw your attention to important information about the projectors.



NOTE: Additional useful details or tips.



CAUTION: Steps to take to avoid damage to your equipment.



WARNING: Steps to take to avoid personal injury.

These graphics are used on the projector's labels.



Attention - Refer to this User's Guide for important safety information.



CAUTION: Hot Surfaces - Avoid touching hot surfaces. Do not touch until the projector has cooled.

Do Not Look Into The Lens!

Be extremely careful not to look into the projection lens when the projector is turned on. The bright light may harm your eyes. Be especially careful to keep children from looking into the lens.

Power Source

Use only a three-wire grounding type power source. The power source should not exceed 270 Volts RMS between the supply conductors or between either conductor and earth ground.

Power Cord

Use only the power cord that was shipped with the projector. Although other power cords might be similar in appearance, they have not been safety-tested with the projector. Do not use a power cord if it has become damaged or frayed. Contact Boxlight at 1-800-762-5757 if you need to replace your power cord.

Grounding

The projector is grounded through the grounding conductor on the power cord. To avoid electric shock, plug the power cord into a properly wired receptacle. Do not defeat the purpose of the grounding-type plug.

Lamp

To avoid overheating and unacceptable image quality, replace the projection lamp with a lamp of the specified type. Refer to page 45 for lamp specifications and to page 37 for instructions on replacing the lamp.

Lamp Compartment

To avoid burns, do not open the lamp module door until the projector is turned off and the lamp has cooled for at least 30 minutes. Follow the instructions in this manual for lamp replacement carefully.

Hot Surfaces

Allow the projector to cool at least 30 minutes before replacing a lamp. When you open the lamp housing, be very careful not to touch the hot surfaces inside.

Ventilation and Overheating

Openings in the projector case provide ventilation to protect it from overheating. Keep loose papers and other objects well away from the grills. Do not place the projector on top of or close to a computer or other heat-producing equipment.

Liquid Spills

Do not set drinks on top of the projector. Spilled liquids can flow inside and cause damage.

Do Not Disassemble

All service must be performed by Boxlight. The only user-serviceable parts in the projector are the projection lamp, which you can replace by opening the lamp cover on the side of the projector (see page 37) and the fan intake filter (see page 35). Do not open any other part of the projector.



.....
NOTE: *If you open the projector case, you will void the warranty.*

INTRODUCTION

The Boxlight 9000 is an XGA multimedia projector designed for fixed installations. It allows 3 computer and 2 video inputs, along with RS-232 control.

Image Resolution

The Boxlight 9000 can display VGA, SVGA, XGA, and SXGA images. The native resolution of the projected image is XGA 1024x768. Screen resolutions between 1024x768 and 1280x1024 are compressed to 1024x768. The projector cannot compress screen resolutions above 1280x1024. If your computer's screen resolution is higher than 1280x1024, reset it to a lower resolution before you connect the projector.

Compatibility

The projector is compatible with a wide variety of computers and video devices, including:

- IBM-compatible computers, including laptops, up to 1280x1024 resolution at 75 Hz.
- Apple Macintosh and PowerBook computers up to 1280x1024 resolution.
- Selected workstations (contact Boxlight for details).
- Most standard VCRs, camcorders, DVD and laser disc players.

Unpacking the Projector

The projector comes with the items shown in Figure 1. Check to make sure all are included. Contact Boxlight immediately if anything is missing.

If you are experienced in setting up presentation systems, use the *Boxlight 9000 Quick Start* card that was included in the shipping box. For complete details on connecting and operating the projector, refer to this User's Guide.



NOTE: The projector automatically expands 640x480 and 800x600 images to fill the screen. You can display these images at their original resolutions by turning off the Auto Resize feature. See "Auto Resize" on page 31 for more information.



NOTE: The projector is compatible with many third-party controllers and amplifiers, including AMX, Crestron, and Extron. Call Boxlight for details.



NOTE: For model 9000-INT: To use video input, an optional video board must be installed in the projector. Contact Boxlight for more information.



NOTE: For model 9000-INT: To use video input, an optional video board must be installed in the projector. Contact Boxlight for more information.

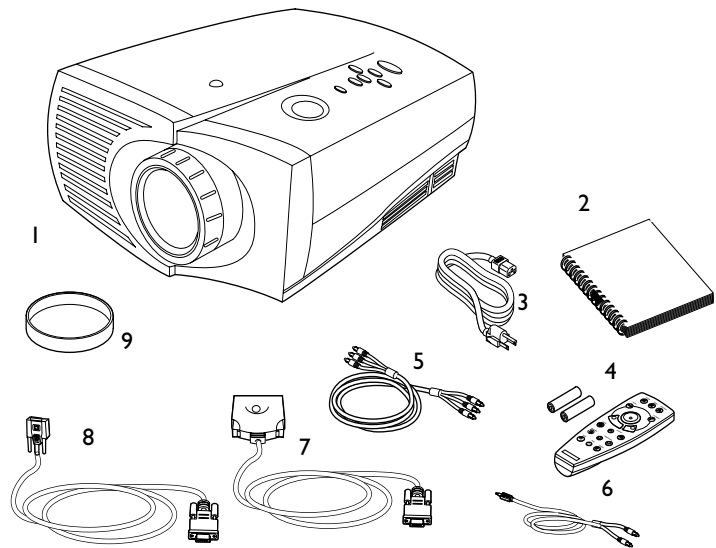

FIGURE I

Shipping box contents

- | | |
|--------------------------------------|---------------------------------|
| 1. Boxlight 9000 projector | 6. computer audio cable |
| 2. <i>Boxlight 9000 User's Guide</i> | 7. CablePro Lite computer cable |
| 3. power cord | 8. VESA computer cable |
| 4. remote and batteries | 9. lens cap |
| 5. VCR cable (RCA A/V cable) | |

Not shown: Quick Start card



NOTE: Long throw and short throw lenses are also available.

See "Optional Accessories" on page 47.

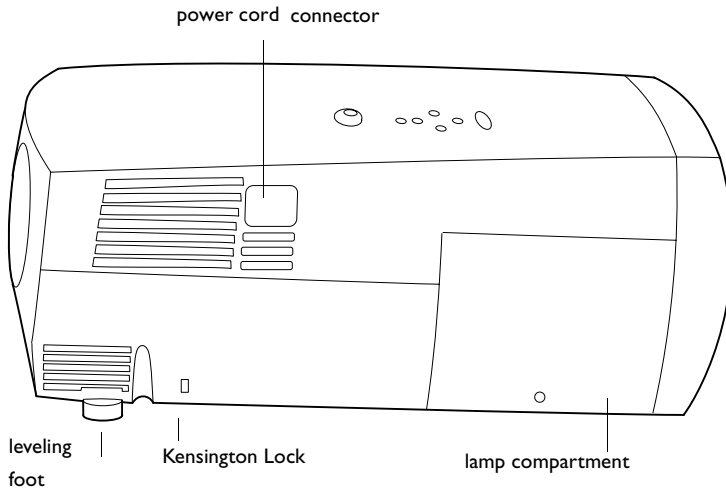

FIGURE 2

Side view of projector

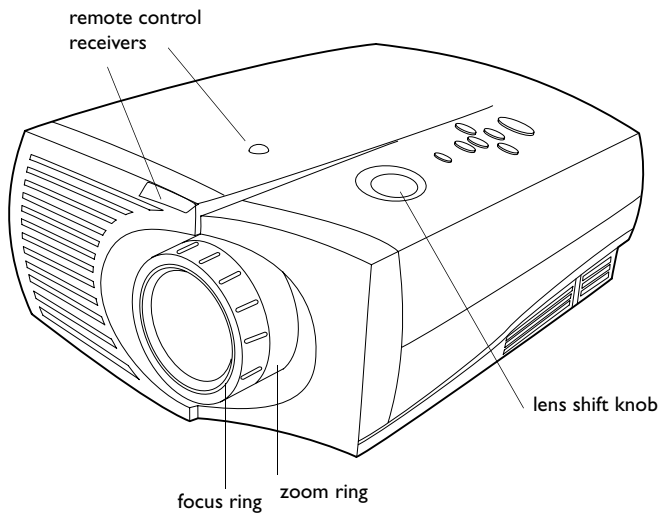

FIGURE 3

Front view of projector

Usage Guidelines

- Do not look directly into the projection lens when the projector is turned on. The bright light may harm your eyes.
- Do not block the grills on the projector. Do not place the projector on cloth table coverings, as they may get sucked up to the vents. Restricting the air flow can cause the projector to overheat and turn off.
- Handle the projector as you would any product with glass components. Be especially careful not to drop it.
- Avoid leaving the projector in direct sunlight or extreme cold for extended periods of time. If this happens, allow it to reach room temperature before use.
- This projector is not intended for use in mainframe computer rooms as defined in the Standard for the Protection of Electronic Computer/Data Processing Equipment, ANSI/NFPA 75.
- Transport the projector in a vendor-approved hard or soft case. Call Boxlight to order.

If You Need Assistance

The first place to look for help is in this manual. Be sure to check the guidelines in “Troubleshooting” on page 40.

If this manual doesn’t answer your question, call Boxlight at **1-800-762-5757**.

Warranty

This product is backed by a limited one-year warranty. The details of the warranty are printed at the back of this manual.

SETTING UP THE PROJECTOR

- 1 Place the projector on a flat surface.
 - The projector must be within 7.5 feet (2.3 m) of your power source.
 - If you are installing the projector on the ceiling, refer to the *Ceiling Mount Installation Guide* that comes with the Ceiling Mount Kit for more information. To turn the image upside down, see “Ceiling” on page 34. The Ceiling Mount Kit is sold separately; see page 48.
- 2 Position the projector the desired distance from the screen.
 - The distance from the lens of the projector to the screen and the zoom lens setting determine the size of the projected image. Table 1 shows example projected image sizes and minimum and maximum distances to the screen.

The formulas for distance to the screen are:

$$\text{Max distance (ft)} = \text{diagonal image size (ft)} \div .541$$

$$\text{Min distance (ft)} = \text{diagonal image size (ft)} \div .716$$

Table 1:
Diagonal Image Size and Width at Maximum and Minimum Distance to Screen-Zoom Lens

Diagonal Image Size (inches)	Image Width (inches)	Distance to screen	
		Maximum distance (feet)	Minimum Distance (feet)
300	240	46.3	35.0
240	192	37	28.0
180	144	27.8	21
144	115	22.2	16.8
120	96	18.5	14
96	77	14.8	11.2
72	58	11.1	8.4
60	48	9.3	7
48	38	7.4	5.6



NOTE: For a similar table for the optional long throw and short throw lenses, see page 54 of the Appendix.

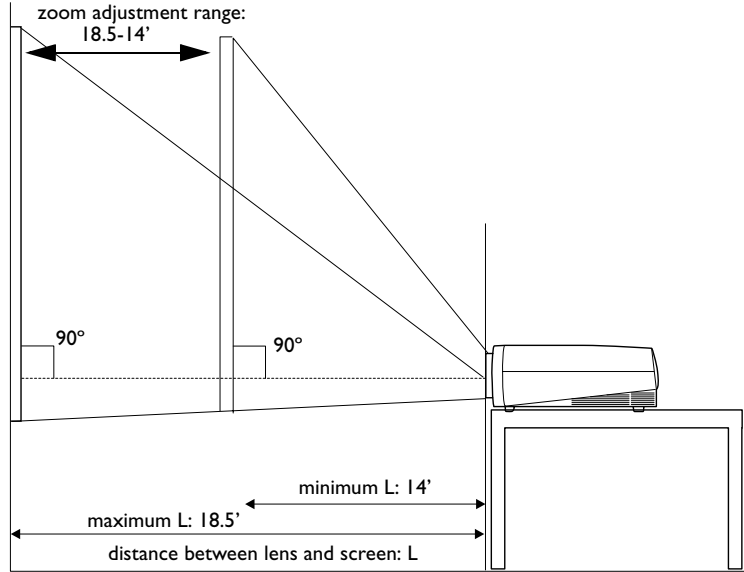

FIGURE 4

Projected image size for 10' diagonal image size

The projector is equipped with a lens shift feature that allows you to adjust the projection height (move the image along the wall) without moving the projector, while still maintaining a perfectly square image. Turn the lens shift knob on top of the projector to make this adjustment (see Figure 3 on page 3).

The bottom of the image can move from half way below the projector's lens (Figure 5) to 25% above the lens (Figure 6).

Example: With a 10' image, at the lowest projection angle, the bottom of the image is 5' below the projector's lens; at the highest projection angle, the bottom of the image is 2.5' above the lens.



NOTE: The lens shift is not adjustable on the optional short throw lens. It is fixed at zero degrees.

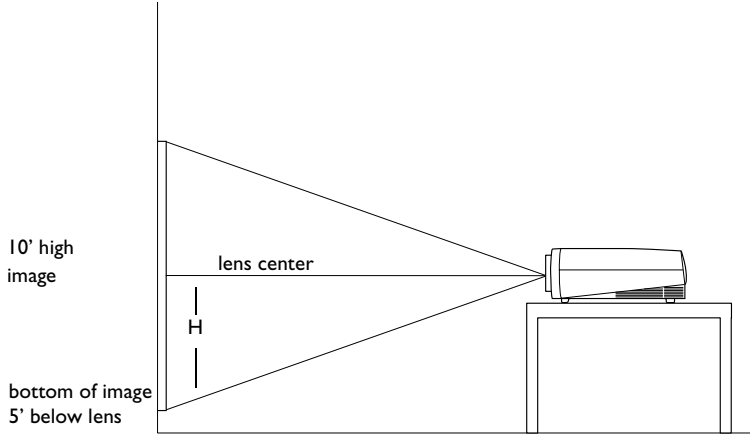

FIGURE 5

Lowest image projection angle

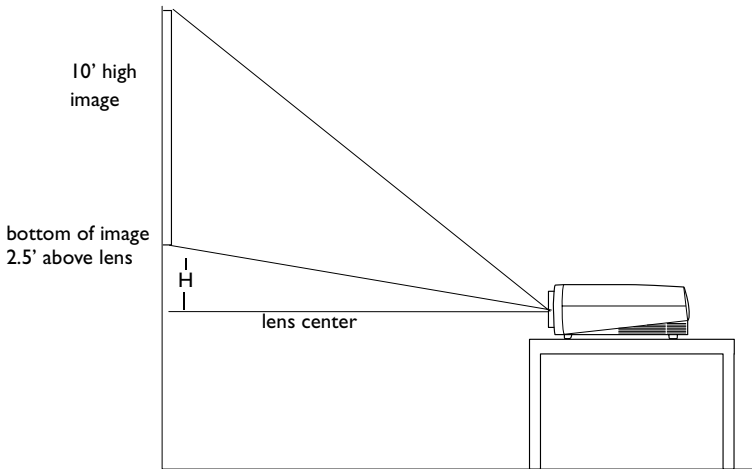

FIGURE 6

Highest image projection angle

Once you know the diagonal image size, you can figure out the width and height using these formulas:

$$\text{width (inches)} = \text{diagonal (inches)} \times 0.8$$

$$\text{height (inches)} = \text{width (inches)} \times 0.75$$

The following tables give the lens shift values for desktop and ceiling-mounted setups for various image sizes. The lower lens shift position represents the highest the projector can be above the bottom of the screen; the upper lens shift position represents the lowest the projector can be below the bottom of the screen.

*Table 2:
Lens Shift Positions for Desktop Setup*

Diagonal Image Size (inches)	Distance from lens center to lower edge of screen (H)	
	Lower lens shift position (inches)	Upper lens shift position (inches)
300	-89.7	46.6
240	-71.7	37.2
180	-53.8	27.9
144	-43.0	22.3
120	-35.9	18.6
96	-28.7	14.9
72	-21.5	11.2
60	-17.9	9.3
48	-14.3	7.4

When the projector is ceiling mounted, use the upper edge of the screen as the base line.

*Table 3:
Lens Shift Positions for Ceiling-Mounted Setup*

Diagonal Image Size (inches)	Distance from lens center to upper edge of screen (H)	
	Lower lens shift position (inches)	Upper lens shift position (inches)
300	89.7	-46.6
240	71.7	-37.2
180	53.8	-27.9
144	43.0	-22.3
120	35.9	-18.6
96	28.7	-14.9
72	21.5	-11.2
60	17.9	-9.3
48	14.3	-7.4

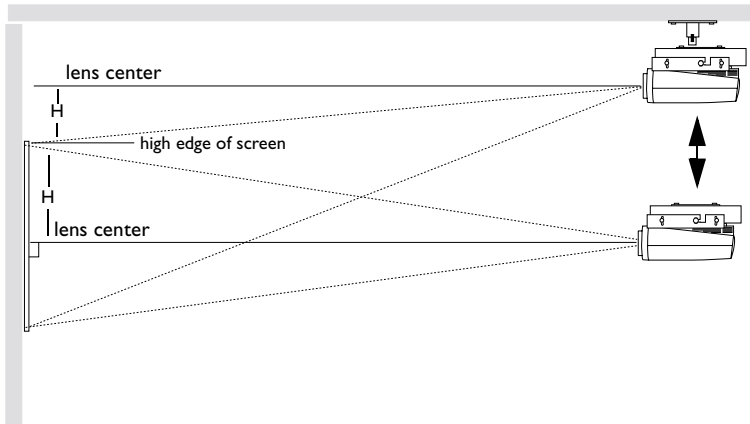

FIGURE 7

Lens shift with ceiling-mounted projector

Now you're ready to connect your equipment.

Steps for connecting the different types of equipment are given on the pages listed below.

Equipment you want to connect	Page
IBM-compatible computer with CablePro Lite	page 11
Macintosh computer with CablePro Lite	page 12
Computer with VESA cable	page 13
Computer with BNC cables	page 13
Video player	page 14
External speaker	page 15
Remote cable	page 16
RS-232 cable	page 16



NOTE: For model 9000-INT: To use video input, an optional video board must be installed in the projector. Contact Boxlight for more information.

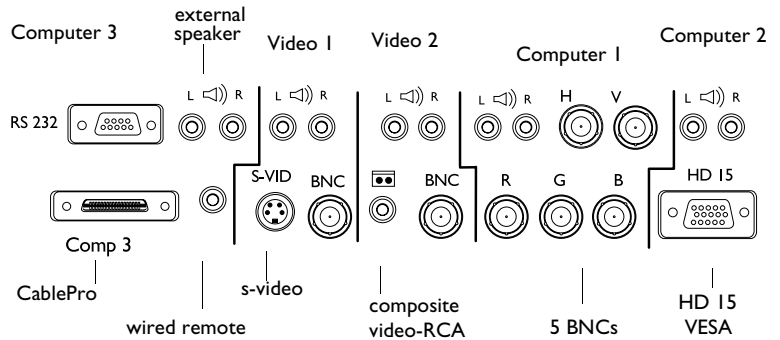

FIGURE 8

Connector panel

The projector has the following audio/video inputs:

Source	Video	Audio
Computer 1	3 Single-ended analog RGB + 2 H&V sync (5 BNCs)	Left and right line-level (2 RCAs)*
Computer 2	VESA Single-ended analog RGB (HD-15)*	Left and right line-level (2 RCAs)*
Computer 3	CablePro Analog RGB*	
Video 1	S-video Y/C (4-pin circular) OR Base-band composite video (BNC)	Left and right line-level (2 RCAs)*
Video 2	Base-band composite video (RCA)* OR Base-band composite video (BNC)	Left and right line-level (2 RCAs)*

*indicates cable included with projector





NOTE: For the connection pin assignments, see page 55.

Connecting an IBM-Compatible Computer Using the CablePro Lite Cable

The CablePro Lite cable provides a computer connection. If you want audio, mouse control, or monitor loop-through, purchase the optional CablePro. See “Optional Accessories” on page 47.

This input is designated Computer 3.

- 1 Plug the  end of the CablePro Lite computer cable into the video connector on your computer.
- 2 Plug the  end of the CablePro Lite computer cable into the Computer 3  connector on the projector.

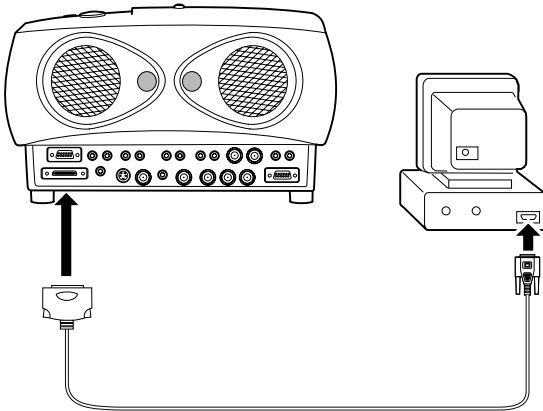

FIGURE 9

Connecting the CablePro Lite computer cable to an IBM-compatible computer







NOTE: Many laptop computers do not automatically turn on their external video port when a secondary display device such as a projector is connected. Refer to your computer manual for the command that activates the external video port. Activation commands for some laptop computers are listed in the Appendix of this manual on page 49.

Connecting a Macintosh Computer Using the CablePro Lite Cable

The CablePro Lite cable provides a computer connection. If you want audio, mouse control, or monitor loop-through, purchase the optional CablePro. See “Optional Accessories” on page 47.

This input is designated Computer 3.

- 1 Plug the  end of the CablePro Lite computer cable into the Boxlight Macintosh adaptor (sold separately).
- 2 Plug the CablePro Lite/Mac adaptor into the video connector on your computer (or the Apple video-out cable or monitor adaptor, if needed).
- 3 Plug the  end of the CablePro Lite computer cable into the Computer 3  connector on the projector.
- 4 If you want the projector display to be the same as the PowerBook’s screen display, turn on video mirroring (called SimulScan in newer PowerBooks). See “Using Video Mirroring with a PowerBook Computer” on page 53 for additional information.

 **NOTE:** Some PowerBooks require the Apple-supplied video-out cable or monitor adaptor for external video. Connect it between the PowerBook and the CablePro Lite computer cable/Mac adaptor as shown in Figure 10.

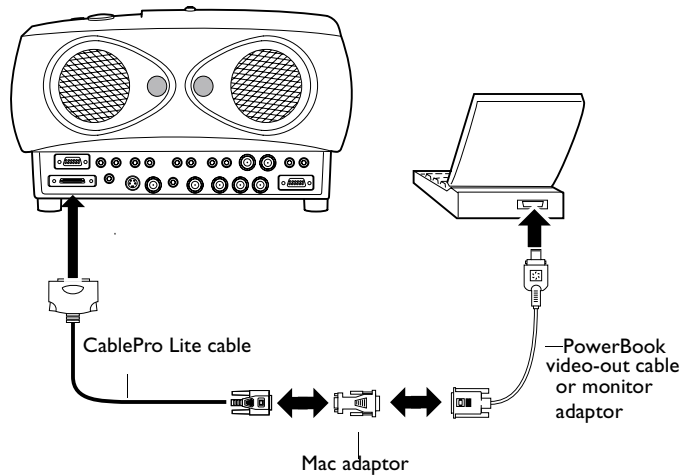



FIGURE 10

Connecting the CablePro Lite computer cable to a Macintosh

Connecting a Computer Using a VESA cable

The supplied VESA cable connects to the High Density 15-pin connector (HD 15) on the projector. This input is designated Computer 2.

- 1 Plug one end of the VESA cable into the video connector on your computer. Plug the other end into the HD 15 connector on the projector.
- 2 If you want audio with your presentation, plug the supplied audio cable into the audio connector on your computer. Plug the other end into the  connectors on the projector above the HD 15 connector.

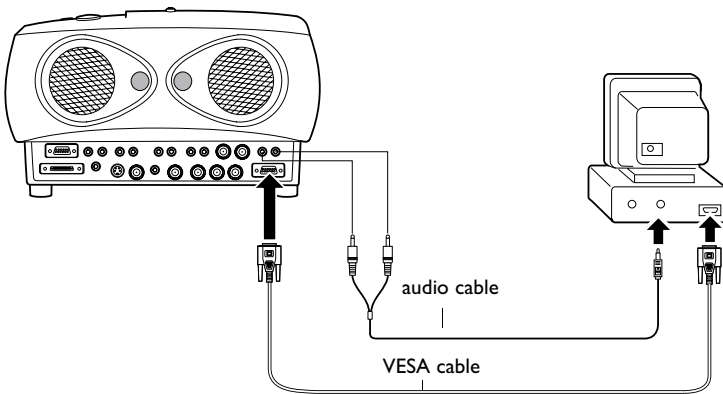

FIGURE 11

Connecting the a computer with the VESA cable

Connecting a Computer using BNC cables

This input is designated Computer 1.

Connect the BNC cables to the appropriate connectors on the projector (Figure 8 on page 10) and on your computer. See “Connection Pin Assignments” on page 55 for more information.



NOTE: For model 9000-INT: To use video input, an optional video board must be installed in the projector. Contact Boxlight for more information.

Connecting a Video Player

- 1 If your video player uses a round, one-prong composite video connector, you'll need only the A/V cable that shipped with the projector. (Refer to Figure 14 on page 16 to see the connector types.)
 - If your video player uses a round, four-prong S-video connector, you'll need an S-video cable in addition to the A/V cable. If your video player uses a BNC connector, you'll need a BNC cable in addition to the A/V cable. The cables are sold separately. (See "Optional Accessories" on page 47.)
- 2 Plug the A/V cable's yellow connector into the "video-out" port on your video player. This port may be labeled "To Monitor."
 - If you're using an S-video cable, connect it to the "s-video out" connector on the video player. If you're using a BNC cable, connect it to the BNC connector on the video player (Figure 12).
- 3 Plug the other yellow connector into the composite connector on the back of the projector (labeled  under Video 2).
 - If you're using S-video or BNC, plug the other end of the cable into the "S-VID" or "BNC" connector on the projector (Figure 12).

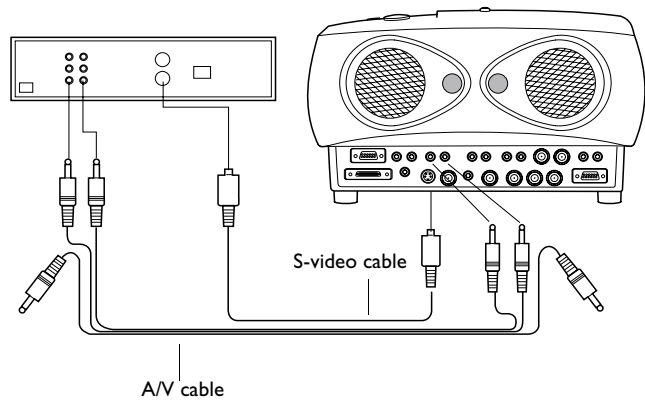



FIGURE 12

Connecting the projector to a video player using an S-video cable and the audio connectors on the standard A/V cable

- 4 Plug the A/V cable's white connector into the left "audio out" port on your video player. Plug the cable's red connector into the right "audio out" port on the video player.
 - If you're using an S-video or BNC cable, the yellow connectors on the A/V cable remain unused (Figure 12).
- 5 Plug the A/V cable's other white and red connectors to the left and right "audio in" ports on the projector directly above your video connection.

The projector is compatible with these major broadcast video standards: NTSC, NTSC 4.43, PAL, PAL-M, PAL-N and SECAM. It automatically adjusts to optimize its performance for the incoming video. The input signals for SECAM, PAL-M, and PAL-N video cannot be automatically detected, therefore they must be chosen manually; see "Video Standard" on page 33.

Connecting an External Speaker

To connect one or two external speakers, plug the speaker cable into the  (audio out) connectors on the projector. The external speaker's volume is controlled by the projector; see "Volume" on page 25.

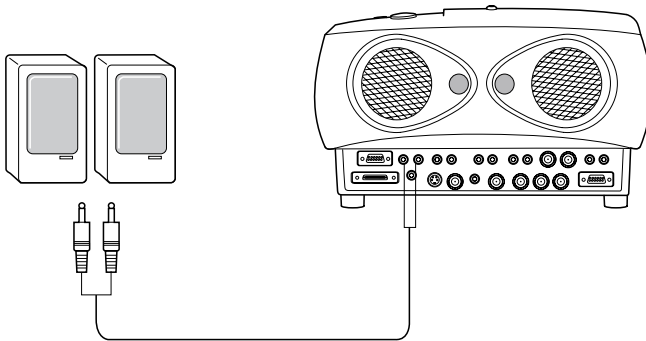

FIGURE 13

Connecting external speakers



CAUTION: Your video player may also have a "Video Out" port for a coaxial cable connection. **DO NOT** use this to connect to the projector.



NOTE: For more information on using the remote, see page 21.

Connecting the Remote Control Cable

If the projector cannot receive the remote's signal, as may be the case if you're using rear projection, connect the remote directly to the projector with the remote cable.

- 1 Plug the remote cable into the  connector on the projector.
- 2 Plug the other end into the connector on the remote.

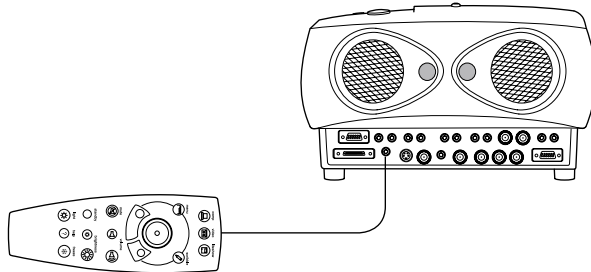

FIGURE 14

Connecting the remote control cable

Connecting a Computer with an RS-232 Cable

You can control the projector from an LCD control panel by connecting an RS-232 cable to the projector (see Figure 8 on page 10). See "RS232 Terminal Specifications" on page 57 for details.



NOTE: Always use the power cord that shipped with the projector.

Powering up the Projector and Adjusting the Image

- 1 Remove the lens cap.
- 2 Plug the power cord into the side of the projector, then plug it into your electrical outlet. A surge-protected power strip is recommended if power surges are common in your area.
- 3 Turn on the projector by pressing the power button on the remote or keypad.
 - The startup screen displays.

4 If you connected a video player, turn it on.

- The image is displayed. If another source is active, press the **video 1** or **video 2** button on the remote to display the image from your video player, or press the Source button on the keypad to cycle through the sources. (You can select a default source to determine which source the projector examines first during power-up for active video; see “Default Source” on page 34.)
- Use the **volume** buttons to adjust the volume.
- If you don’t want to hear the sound from your video player, press the **mute** button.

5 If you connected any external speakers, turn them on.

6 Turn on your computer.

- The image is displayed. If another source is active, press the **computer 1, 2, or 3** button on the remote to display the image from your computer, or press the Source button on the keypad to cycle through the sources.
- You can make adjustments to the image from the projector’s on-screen menus. To open the menus, press the **menu** button on the keypad or remote. Then select the Display menu or the Image menu. For more information about the menus, see page 25.
- If you don’t want to hear the sound from your computer, press the **mute** button.

Turning Off the Projector

To turn the projector off, press the power button on the remote or keypad. The lamp stays on for 15 seconds, then turns off. The fan continues to run until the projector has cooled.

If you press power again within 15 seconds, the projector returns to normal operation immediately.



NOTE: For model 9000-INT: To use video input, an optional video board must be installed in the projector. Contact Boxlight for more information.



NOTE: With some computers, the order in which you power up the equipment is very important. Most computers should be turned on last, after all other peripherals have been turned on. Refer to your computer’s documentation to determine the correct order.



CAUTION: When you disconnect the projector after you have switched it off, always remove the power cord from the electrical outlet first, then remove it from the projector.

USING THE PROJECTOR

This section describes how to use and make adjustments to the projector. It also provides a reference to the remote and keypad buttons and the options available from the on-screen menus.

Basic Image Adjustment

- 1** Make sure you have powered up your equipment in the right order (page 16).
- 2** If the image doesn't display completely, adjust the height and tilt of the projector (page 20), zoom the image (page 20), or center the image by adjusting its horizontal or vertical position (page 32).
- 3** If the image is out of focus, rotate the lens to focus it (page 20).
- 4** If the image appears to shimmer or if it has blurry vertical bars after you have adjusted the focus, turn Auto Image (page 31) off and then back on to reset the automatic sync and tracking. If that doesn't clear up the image, adjust the sync (page 32) and/or the tracking (page 32) manually.
- 5** If the colors don't look right, adjust the brightness, contrast, and tint (page 27), and color and color temperature (page 28.)

Adjusting the Projector

To focus the image, rotate the focus ring (Figure 15) until the image is clear. To zoom the image, rotate the zoom ring. This adjusts the image size without affecting focus.

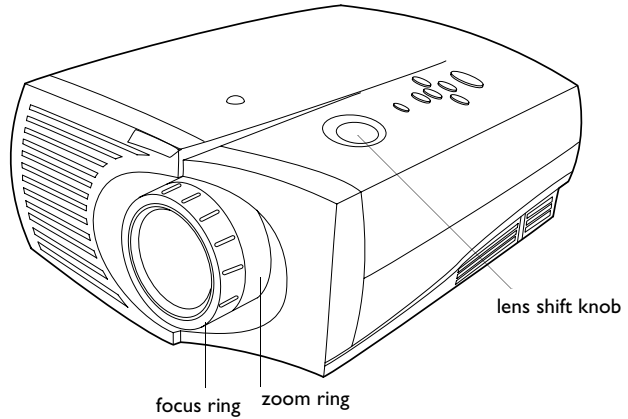

FIGURE 15

Focus ring and zoom ring

The projector is equipped with a projection angle lens shift knob that provides 18 degrees of adjustment from horizontal. This allows you to adjust the projection height without moving the projector (see page 6 for lens shift values). It also has a height-adjustment foot and a leveling knob (Figure 17).

To adjust the height of the projector, lift the projector and move the foot to the desired position. Rotate the leveling knob, if necessary, to adjust the angle of the projected image.

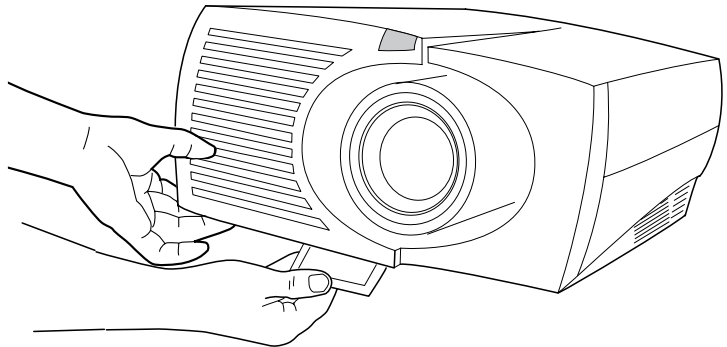

FIGURE 16

Adjusting the foot

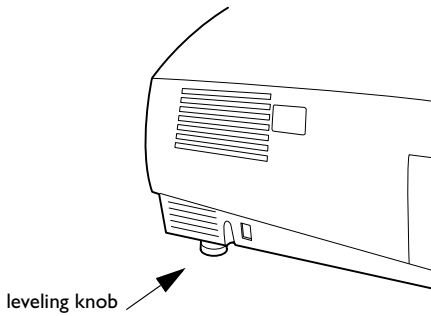

FIGURE 17

Leveling knob

Using the Remote Control

Point the remote control at the projection screen or at the projector. The range for optimum operation is about 30 feet. If you point the remote at the projection screen, the distance to the screen and back to the projector must be less than or equal to 30 feet. For best results, point the remote directly at the projector.

If you have purchased the optional CablePro and are creating presentations in Microsoft® PowerPoint®, you can use the remote's mouse buttons to navigate through your presentation while in Slide Show mode. To configure PowerPoint for this, choose Options from the Tools menu, click the View Tab, de-select the "Popup Menu on Right Mouse Click" option in the Slide Show section, then click OK. Then, when you're in PowerPoint's Slide Show mode, a left click advances to the next slide and a right click returns to the previous slide (other PowerPoint modes are not affected).



NOTE: *If you can't aim the remote control at the projector so that its signal is received — for example, when using rear projection or in a large auditorium— connect it directly to the projector with the optional remote control cable.*



NOTE: *If you want mouse control of the Computer 3 input, purchase the optional CablePro. If you want mouse control of multiple sources, purchase a third-party mouse.*



NOTE: For model 9000-INT: To use video input, an optional video board must be installed in the projector. Contact Boxlight for more information.

Using the Remote and Keypad Buttons

This section provides an alphabetical reference to the remote and keypad buttons.

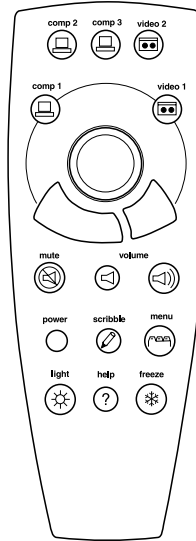

FIGURE 18

Remote control

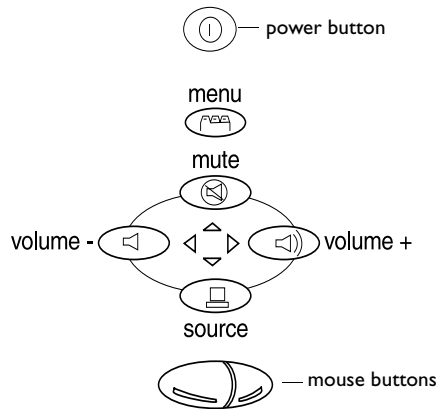

FIGURE 19

Keypad

Computer 1, 2 and 3

When you have more than one source (computer or video) connected to the projector, select between them by pressing the button for the source you want.

Press **computer 1, 2, or 3** to display your computer image or LiteShow Pro presentation.

Freeze

The **freeze** button halts, or “freezes” the projected image. Use this button to freeze a frame of video (the video continues to run but the projected image is frozen). You can also freeze an image from a computer source on the screen, allowing you to perform other operations on the computer without the audience seeing them. Press **freeze** again when you want the image to return to normal.

Help ?

This displays the help information.

Light

Press **light** to illuminate the buttons on the remote control. The light goes off automatically 10 seconds after you press any button.

Menu

Press **menu** to open the on-screen menus. Press **menu** again to close the menus. When you close the menus, the projector saves any changes you made. For more information about the on-screen menus, see page 25.

Mute

Pressing the **mute** button silences the internal speakers. It also silences any external speakers that are connected.

To return the volume to its previous setting, press **mute** again or press either **volume** button.



NOTE: It takes a few seconds for the projector to recognize a new source. After the first time, the source is recognized immediately.



NOTE: For model 9000-INT: To use video input, an optional video board must be installed in the projector. Contact Boxlight for more information.

Scribble

The **scribble** button activates on-screen annotation.

- 1 Press the **scribble** button. The cursor changes to a pencil.
- 2 Press the right disk mouse button (Figure 20 on page 25) to display the color selector. Use the disk mouse to position the cursor on the desired color, then press the left mouse button. Press the right button again to close the color selector.
- 3 Use the disk mouse to move the pencil to where you want to start the annotation.
- 4 Press the left mouse button. The cursor changes to an upright pencil.
- 5 Use the disk mouse to draw your annotation. Press the left mouse button to complete the annotation.
- 6 To exit Scribble, press the **scribble** button. The annotation is automatically deleted (it cannot be saved).

Power

The Power button turns the projector on and off, and functions the same on the keypad and remote. When you press power while the projector is on, the lamp stays on for 15 seconds before shutting off. If you press power again within 15 seconds, the projector returns to normal operation immediately. If you don't press power again, the lamp turns off after 15 seconds. The fan continues to run until the projector has cooled (approximately 30 seconds).

Video 1 and 2



When you have more than one source (computer or video) connected to the projector, select between them by pressing the button for the source you want.

Press **video 1** or **2** to display the image from your video player.



NOTE: For model 9000-INT: To use video input, an optional video board must be installed in the projector. Contact Boxlight for more information.

Volume

- To increase the volume, press 
- To decrease the volume, press 

Volume adjustments are saved for each source you have connected (including external speakers).

Using the On-Screen Menus

The projector has four on-screen menus that allow you to make image adjustments and change a variety of settings. Most of these adjustments aren't available directly from the keypad or remote.

To open the on-screen menus, press the **menu** button on the keypad or remote. This changes the volume, source, and mute buttons on the keypad to menu navigation buttons (and illuminates the keypad green). Press the corresponding buttons to move the cursor up, down, left, or right. To select a menu, use these buttons to move the cursor to the tab for the menu you want, then click either mouse button. To change a menu setting, move the cursor to the setting you want to change using the navigation buttons, then use one of the two mouse buttons to make changes. Press **menu** again when you want to close the menus. All changes are saved when you close the menus.

To select a menu using the remote, use the disk mouse to move the cursor to the tab for the menu you want, then click either mouse button.

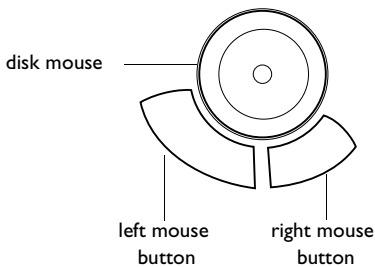

FIGURE 20

Disk mouse and mouse buttons on remote



NOTE: Some options in the menus are only available when certain equipment is connected. For example, the Fade setting in the Audio menu is only active if external speakers are connected.



NOTE: For model 9000-INT: To use video input, an optional video board must be installed in the projector. Contact Boxlight for more information.

The status bar at the top of the menu display indicates the source that is currently active (Computer or Video) and any peripherals that are connected.

The status bar also contains a lamp hour counter that starts at zero hours and counts each hour the lamp is in use (it does not continue counting while in standby mode). Change the bulb when the brightness is no longer acceptable. See “Replacing the Projection Lamp” on page 37.

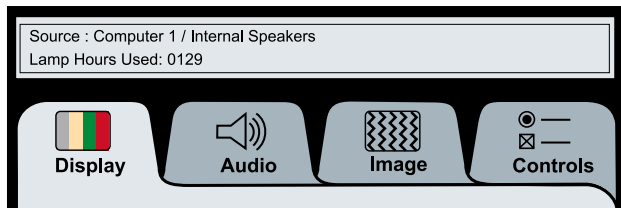

FIGURE 21

On-screen menu status bar

Display Menu Functions

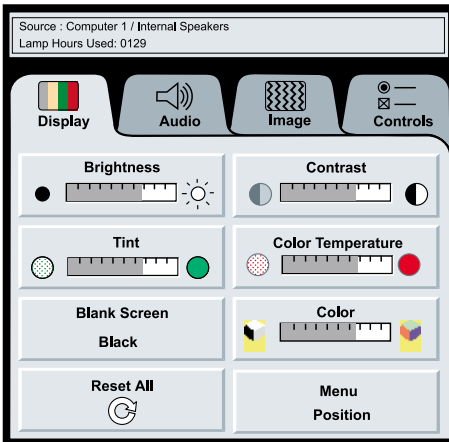

FIGURE 22

Display menu

Brightness

Adjusting the brightness changes the intensity of the image.

- Press the left mouse button to darken the image; press the right mouse button to lighten the image.

Contrast

The contrast controls the degree of difference between the lightest and darkest parts of the picture. Adjusting the contrast changes the amount of black and white in the image.

- Press the left mouse button to decrease the contrast; press the right mouse button to increase the contrast, making the blacks appear blacker and the whites appear whiter.

Tint

The **Tint** setting adjusts the amount of green in the projected image.

- Press the left mouse button to decrease the amount of green in the image; press the right mouse button to increase the amount of green in the image.



NOTE: *If you want to display a blank screen while you're presenting, simply select an inactive source with the remote or keypad.*



NOTE: *For model 9000-INT: To use video input, an optional video board must be installed in the projector. Contact Boxlight for more information.*

Color Temperature

The **Color Temperature** setting adjusts the amount of red in the projected image.

- Press the left mouse button to decrease the amount of red in the image; press the right mouse button to increase the amount of red in the image.

Blank Screen

Blank Screen determines what color is displayed when there is no active source.

- Click the "Black" button to change the option to display a blank blue screen; click the "Blue" button to display a blank black screen.

Color

The **Color** setting adjusts a video image from black and white to fully saturated color. It does not affect computer images.

- Press the left mouse button to decrease the amount of color in the image; press the right mouse button to increase the amount of color in the image.

Reset All

Click either mouse button to reset all the options (except Language, Rear Projection, Ceiling, and Video Standard) in all the menus to their original settings. This also returns Freeze and Mute to their default (off) settings.

Menu Position

This lets you move the menu to various locations on the screen, allowing you to view different parts of the image while making adjustments. The default position is the center of the screen. Click Menu Position to move the menu to the upper-left corner; click it again to move it to upper-right, then lower right, then lower left, then center again.

Audio Menu Functions

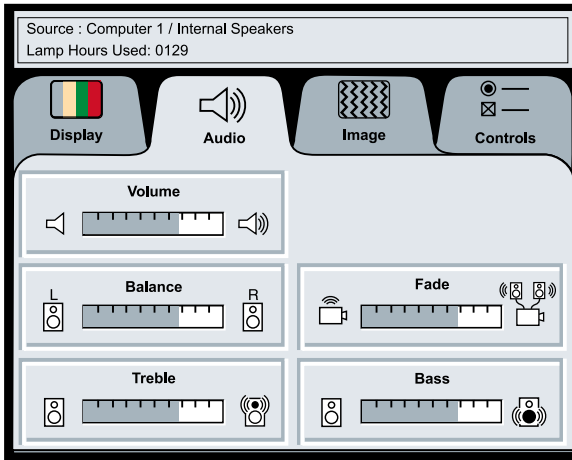

FIGURE 23

Audio menu

Volume

- Press the left mouse button to decrease the volume; press the right mouse button to increase the volume.

Volume adjustments you make are saved for each source (including external speakers).

Balance

The **Balance** setting controls the balance between the left and right speakers. The **Balance** setting applies to all sources you have connected.

- Press the left mouse button to increase the amount of sound coming from the left speaker; press the right mouse button to increase the amount of sound coming from the right speaker.



NOTE: Changing the volume from the menu is the same as changing it using the keypad or remote.



NOTE: *The **Treble** and **Bass** settings apply only to the projector's internal speakers. External speakers typically have their own tone controls.*

Fade

The **Fade** setting controls the balance between the internal and external speakers. The setting appears gray and won't highlight if external speakers aren't connected.

- Press the left mouse button to increase the amount of sound coming from the internal speaker; press the right mouse button to increase the amount of sound coming from the external speakers.

Treble

The **Treble** setting controls the higher frequencies of your audio source.

- Press the left mouse button to decrease the treble; press the right mouse button to increase the treble.

Bass

The **Bass** setting controls the lower frequencies of your audio source.

- Press the left mouse button to decrease the bass; press the right mouse button to increase the bass.

Image Menu Functions

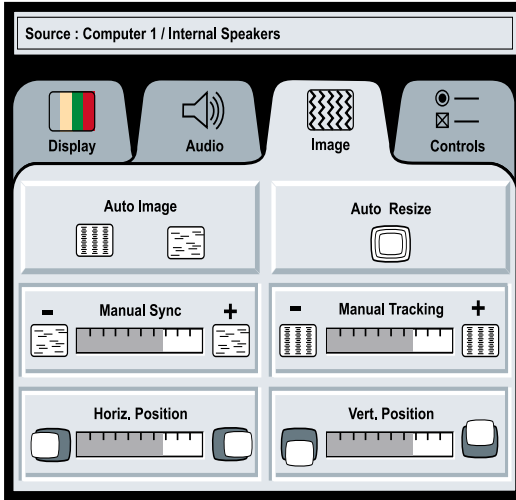

FIGURE 24

Image menu

Auto Image

When **Auto Image** is on, the projector automatically adjusts tracking, signal synchronization and vertical and horizontal position for most computers. If you want to adjust these features manually, you must turn off **Auto Image** first by clicking it.

Auto Resize

Auto Resize automatically resizes the image by scaling it up or down.

When **Auto Resize** is on, the projector makes the best fit of the image to the screen. If you turn **Auto Resize** off (by clicking it), the image may be either cropped or too small for the screen.



NOTE: Some screen savers interfere with the operation of Auto Image. If you're experiencing problems, try turning your screen saver off, then turning Auto Image off and back on.



NOTE: The **Manual Sync**, **Manual Tracking**, **Horiz. Position** and **Vert. Position** buttons are available only for computer sources. The projector sets these options automatically for a video source.

Manual Sync

The projector adjusts signal synchronization automatically for most computers. But if the projected computer image looks fuzzy or streaked, try turning **Auto Image** off then back on again. If the image still looks bad, try adjusting the signal synchronization manually as described below.

- 1 Click the **Auto Image** button to turn Auto Image off.
- 2 Press the left or right mouse buttons repeatedly until the image is sharp and free of streaks.

Manual Tracking

The tracking function adjusts the projector to match the video signal from your computer. The projector usually adjusts the tracking automatically when you connect your computer. However, if the display shows evenly spaced, fuzzy, vertical lines or if the projected image is too wide or too narrow for the screen, try turning **Auto Image** off then back on again. If the image is still bad, try adjusting the tracking manually as described below.

- 1 Click the **Auto Image** button to turn Auto Image off.
- 2 Press the left or right mouse buttons repeatedly until the fuzzy vertical bars are gone.

Horiz. Position

Follow these steps to manually adjust the horizontal position.

- 1 Click the **Auto Image** button to turn Auto Image off.
- 2 Press the left mouse button to move the image right; press the right mouse button to move the image left.

Positioning adjustments are saved when you power off the projector.

Vert. Position

Follow these steps to manually adjust the vertical position.

- 1 Click the **Auto Image** button to turn Auto Image off.
- 2 Press the left mouse button to move the image down; press the right mouse button to move the image up.

Positioning adjustments are saved when you power off the projector.

Controls Menu Functions

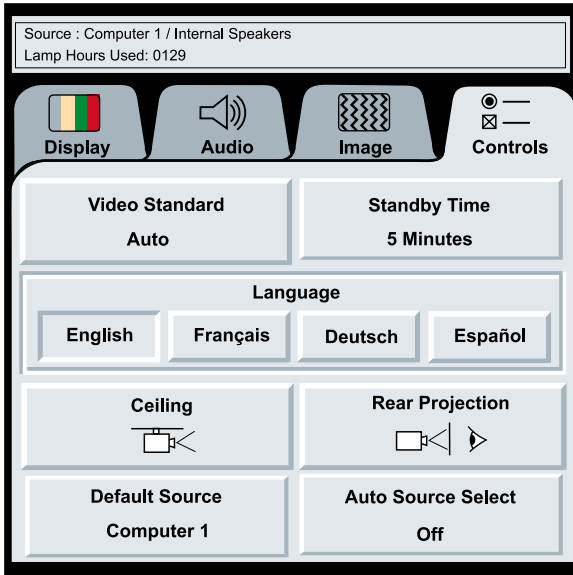

FIGURE 25

Controls menu

Video Standard

When **Auto** is on, the projector attempts to pick the video standard (NTSC, NTSC 4.43, PAL, PAL-M, PAL-N or SECAM) automatically based on the input signal it receives. (The video standard options may vary depending on your region of the world.) The input signals for SECAM, PAL-M, and PAL-N video cannot be automatically detected, therefore they must be chosen manually. If the projector is unable to detect the standard, the colors might not look right or the image might appear “torn.” If this happens, manually select a video standard by clicking the button and cycling through the standards.

Standby Time

This option lets you select how long the lamp stays on and the blank screen is displayed when you enter standby mode before the projector turns off. Select among 1, 5, 10, and 15 minutes by clicking the button and cycling through the options.



NOTE: For model 9000-INT: To use video input, an optional video board must be installed in the projector. Contact Boxlight for more information.



NOTE: If you already know the video standard used in your geographical area, it's often best to manually select it.



NOTE: Standby Time is applicable only when using RS-232 control or a remote that has a standby button.



NOTE: To order the Ceiling Mount, refer to “Optional Accessories” on page 47.



NOTE: For model 9000-INT: To use video input, an optional video board must be installed in the projector. Contact Boxlight for more information.

Language

You can display the on-screen menus in English, French, German, and Spanish. The default is English.

- Click the button for the language you want. The menus redraw immediately.

Ceiling

- Click either mouse button to turn the image upside down for ceiling-mounted projection.

Rear Projection

When you select **Rear Projection**, the projector reverses the image so you can project from behind a translucent screen.

Default Source

Default Source toggles between all five sources. This determines which source the projector checks first during power-up for active video. Click the button to toggle between the options.

Auto Source Select

This setting toggles between On and Off. When this feature is Off, the projector defaults to the source selected in Default Source. To display another source, you must manually select one by pressing the **computer** or **video** buttons on the remote or the **source** button on the keypad. When this feature is On, the projector automatically finds the active source, checking the default source first. Click the button to toggle between the options.

MAINTENANCE AND TROUBLESHOOTING

This section describes how to:

- clean the lens
- clean the fan intake filter
- replace the projection lamp
- replace the batteries in the remote control
- use the Kensington lock feature
- troubleshoot the projector

Cleaning the Lens

Follow these steps to clean the projection lens:

- 1 Apply a non-abrasive camera lens cleaner to a soft, dry cloth.
 - Avoid using an excessive amount of cleaner.
 - Abrasive cleaners, solvents or other harsh chemicals might scratch the lens.
- 2 Lightly wipe the cleaning cloth over the lens.
- 3 If you don't intend to use the projector immediately, replace the lens cap.

Cleaning the Fan Intake Filter

The fan intake filter on the bottom of the projector catches dust and particles in the air. If the filter becomes clogged, the projector does not cool properly and may malfunction. To prevent this, clean the filter after every 100 hours of use.

- 1 Turn off the power and unplug the power cord.
- 2 Remove the filter door (Figure 26).



NOTE: If your projector is ceiling-mounted, refer to the Ceiling Mount Guide for instructions on removing the fan intake filter.

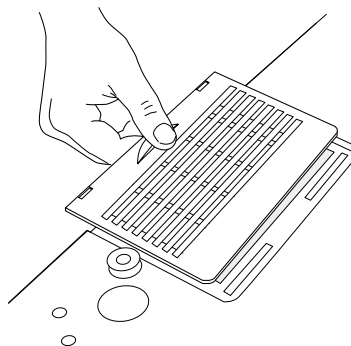

FIGURE 26

Removing the filter door

3 Clean the filter.

- Use a vacuum cleaner set on low power to remove the dust and dirt.

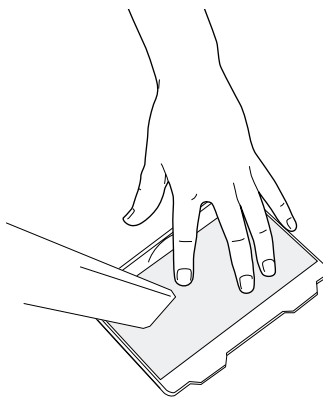

FIGURE 27

Cleaning the air filter

4 Replace the filter.

- First, insert the side with the tabs, then press the other end in place.

Replacing the Projection Lamp

The projector is designed so you can easily change the projection lamp. The lamp hour counter on the status bar at the top of the menu (page 26) counts the number of hours the lamp has been in use. Replace the lamp when the brightness is no longer acceptable. You can order new lamp modules from Boxlight. See “Accessories” on page 47 for information.

Follow these steps to replace the projection lamp:

- 1 Turn off the projector and unplug the power cord.
- 2 Wait 30 minutes to allow the projector to cool thoroughly.
- 3 Using a small, flat-blade screwdriver, remove the screw on the outside of the lamp door.
- 4 Pull the lamp cover up and remove it.
- 5 Loosen the two non-removable screws on the outside of the module.

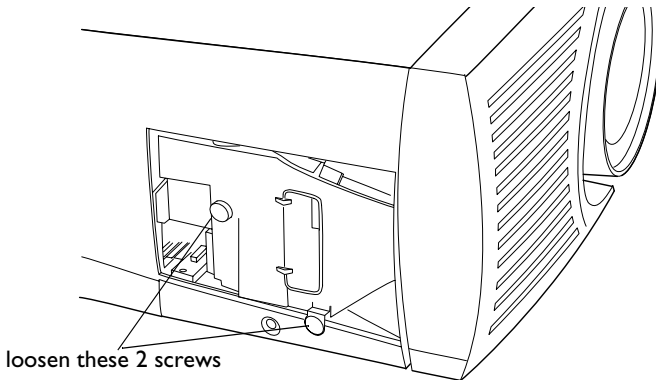

FIGURE 28

Lamp module door removed, showing 2 screws

- 6 Remove the module (Figure 29).



WARNING: To avoid burns, allow the projector to cool for at least 30 minutes before you open the lamp module door. Never extract the lamp module while the lamp is operating.



CAUTION: Never operate the projector with the lamp cover open or removed. This disrupts the air flow and causes the projector to overheat.

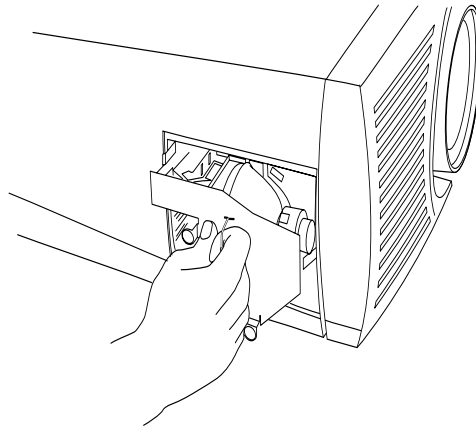

FIGURE 29

Removing the lamp module



.....
WARNING: Do not drop the lamp module or touch the glass bulb! The glass may shatter and cause injury.

- 7** Align the new lamp module in the correct direction.
- 8** Gently push the module in as far as it goes.
- 9** Tighten the screws on the outside of the module.
- 10** Reposition the lamp cover.
- 11** Replace the screw and tighten it.
- 12** Plug in the power cord and turn the projector back on.
- 13** To reset the lamp hour counter in the Status bar, press and hold the left mouse button, then press the menu button (while still holding down the mouse button) for 5 seconds. Verify that the counter was reset by pressing the menu button and viewing the counter (see page 26).

Replacing the Batteries in the Remote Control

The life of the batteries depends on how often and how long you use the remote. Symptoms of low battery charge include erratic responses when using the remote and a reduced range of operation.

Follow these steps to replace the batteries:

- 1 Turn the remote face down in your hand.
- 2 Slide the battery cover off the end of the remote by pressing on it with the heel of your hand.
- 3 Remove the old batteries.
- 4 Install two new AA alkaline batteries. Make sure you install each in the correct direction.
- 5 Slide the battery cover back on the remote.

Using the Kensington Lock

The projector has a Kensington Security Standard connector for use with a Kensington MicroSaver Security System (Figure 30). Refer to the information that came with the Kensington System for instructions on how to use it to secure the projector.

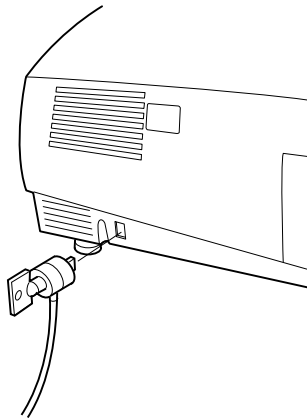

FIGURE 30

Installing the Kensington lock

Troubleshooting

Solutions to Common Problems

Problem: Nothing on projection screen

- Make sure that the power cord is properly connected to a functional AC electrical outlet. Make sure that the power cord is also properly connected to the projector.
- If the projector is plugged into a power strip, make sure the power strip is turned on.
- Make sure you have removed the lens cap on the projection lens at the front of the projector.
- Make sure the projector is switched on.
- Check the projector's lamp to ensure that it is securely connected in the lamp module. See "Replacing the Projection Lamp" on page 37.
- Make sure that the cables do not have any bent pins. Check the power cord for bent pins also.



NOTE: For model 9000-INT: To use video input, an optional video board must be installed in the projector. Contact Boxlight for more information.

Problem: Color or text not being projected

- You might need to adjust the brightness up or down until the text is visible. Refer to "Brightness" on page 27 for more information.
- Verify that the appropriate input source is selected. See "Computer 1, 2 and 3" on page 23 or "Video 1 and 2" on page 24.

Problem: The screen resolution is not right

- Make sure the computer's graphics card is set for a resolution of no greater than 1280x1024.

Problem: Image isn't centered on the screen

- Reposition the image. Refer to "Horiz. Position" on page 32 and "Vert. Position" on page 32.
- If you're using an extension cable, make sure it's Boxlight-approved.

Problem: Only the start-up screen displays

- Verify that the cables are connected correctly.
- Verify that the proper input source is connected. See “Computer 1, 2 and 3” on page 23 or “Video 1 and 2” on page 24.
- You might need to turn everything off and power up the equipment again. Make sure you power up in this order: projector, computer monitor, computer. It is especially important that you follow this sequence for Macintosh computers.
- Make sure your computer’s graphics board is installed and configured correctly.

If you’re using Windows 3.x:

- 1 In the Windows Program Manager, double-click the Windows Setup icon in the Main program group.
- 2 Verify that the Display setting is 1280x1024 or less.

If you’re using Windows 95:

- 1 Open “My Computer” icon, the Control Panel folder and then the Display icon.
- 2 Click the Settings tab.
- 3 Verify that the Desktop area is set to 1280x1024 or less.

Also check the following:

- Does your computer have a compatible graphics board? The projector isn’t CGA or EGA compatible.
- Is your computer’s graphics output port turned on? This is especially true for laptop computers. See “Portable and Laptop Activation Chart” on page 49.

Problem: Image is too wide or narrow for screen

- You might need to manually adjust the tracking to reduce or enlarge the projected image. Refer to “Manual Tracking” on page 32.



NOTE: For model 9000-INT: To use video input, an optional video board must be installed in the projector. Contact Boxlight for more information.

- Adjust the resolution of your monitor if it's greater than 1280x1024. Only this resolution at 75 Hz or less will display on the projector.

Problem: Image is out of focus

- Turn the projection lens to focus the image.
- Make sure the projection screen is at least 6 feet (1.8m) from the projector.
- Check the projection lens to see if it needs cleaning.

Problem: Image and menus are reversed left to right

- Rear projection mode is probably turned on. Switch back to forward projection from the Controls menu. The image should immediately return to forward projection. See "Rear Projection" on page 34.

Problem: Image and menus are upside down

- Ceiling mode is probably turned on. Turn off the mode from the Controls menu. The image should immediately return to forward projection. See "Ceiling" on page 34.

Problem: The projector displays vertical lines, "bleeding" or spots

- Adjust the brightness. See "Brightness" on page 27.
- Check the projection lens to see if it needs cleaning.

Problem: No sound

- Press the mute button.
- Adjust volume.
- Verify audio/input connections.
- Adjust audio source.

Problem: Image is "noisy" or streaked

Try these steps in this order.

- 1 Deactivate the screen saver on your computer.
- 2 Turn **Auto Image** off and then back on again. See "Auto Image" on page 31.

3 Adjust the synchronization and tracking manually to find an optimal setting. See “Manual Sync” on page 32 and “Manual Tracking” on page 32.

- If you’re using an extension cable, make sure it’s Boxlight-approved.
- The problem could be with your computer’s graphics board. If possible, connect a different computer.

Problem: Projected colors don’t match the computer or video player’s colors

- Adjust the brightness, tint and/or contrast from the Display menu. Just as there are differences in the displays of different monitors, there are often differences between the computer image and the projected image. See “Brightness” on page 27, “Tint” on page 27 and “Contrast” on page 27.

Problem: Lamp seems to be getting dimmer

- The lamp begins to lose brightness when it has been in use for a long time. Replace the lamp as described in “Replacing the Projection Lamp” on page 37.

Problem: Lamp shuts off

- A minor power surge may cause the lamp to shut off. Turn the projector off, wait at least 30 seconds, then turn it back on.

Problem: Remote not operating correctly

- You might need to replace the batteries. See “Replacing the Batteries in the Remote Control” on page 39.
- Make sure you’re pointing the remote either at the top or front of the projector, or at the projection screen.
- Make sure the remote is within its operating range of 30 feet.

Problem: When in PowerPoint’s Slide Show mode, the top of the image is cut off and appears at the bottom.

- Turn **Auto Image** off to restore the image. See “Auto Image” on page 31.
- To prevent this from happening in the future, make sure the projector is displaying your presentation in PowerPoint’s Slide mode before entering Slide Show mode.



NOTE: For model 9000-INT: To use video input, an optional video board must be installed in the projector. Contact Boxlight for more information.

Before calling Boxlight for assistance, please have the following information available:

- the projector's serial number (located on the bottom label)
- the computer's type and resolution

Call Boxlight at **1-800-762-5757**.

APPENDIX

Specifications

The projector must be operated and stored within the temperature and humidity ranges specified.

Temperature

Operating	10 C to 40° C
Non-operating	-20 to 70° C

Humidity

Operating and non-oper.	5% to 95% relative humidity, non-condensing
-------------------------	---

Dimensions

13.8 x 20 x 8.0 inches (35 x 50.8 x 20.3 cm)

Weight

24 lbs. (11.3 kg) unpacked

Altitude

Operating	0 to 10,000 feet (3048 meters)
Non-operating	0 to 40,000 feet (12,192 meters)

Optics

Focus Range-zoom lens	6 feet (1.8 m) to infinity
Long-throw lens	15 feet (4.6 m) to infinity
Short-throw lens	2 feet to 12 feet (0.6-3.7 m)

Lamp

Type	350-watt metal halide
------	-----------------------

Remote Control

Battery	Two (2) AA alkaline cells
---------	---------------------------

Input Power Requirements

100/120VAC, 8.0/8.0A, 50/60 Hz 230 VAC, 5A, 50Hz

Audio Input

Input Impedance	8K ohm AC coupled
Maximum Input Voltage	$(L_{IN} + R_{IN})_{PEAK} < 4.5 \text{ V}$ for $\text{THD} \leq 0.3\%$ L_{IN} or $R_{IN} < 2.0 \text{ Vrms}$ for $\text{THD} \leq 0.3\%$
Sensitivity	100 mV at 1 KHz for 88 dB SPL at 1 meter
Connector Type	red and white RCA jacks

Audio Output

Frequency Response	10 Hz - 20 KHz
Output Impedance	1.0K ohm nominal
Output Voltage	2 Vrms maximum (open circuit)
Connector Type	red and white RCA jacks

Accessories

Standard Accessories (ship with the projector)

Boxlight 9000 Quick Start card
Boxlight 9000 User's Guide
Shipping Box
Projection Lamp Module
Lens Cap
Remote Control and 2 Batteries
CablePro Lite 6.5 ft (2 m)
VESA computer cable 6.5 ft (2 m)
Audio/video cable
Audio cable



NOTE: Use only Boxlight-approved accessories. Other products have not been tested with the projector.

Power Cords (one ships with projector, type depends on country)

North American Power Cord
Australian Power Cord
UK Power Cord
European Power Cord

Optional Accessories

Soft Case
ATA Shipping Case
Long throw lens
Short throw lens
CablePro
 CablePro Extension Cable, non-plenum
 rated, 60.7 ft (18.5 m)
 CablePro Extension Cable, plenum-rated,
 60.7 ft (18.5m)
Remote Cable 50 ft (15.3m)
I BNC to I BNC (composite video) 6.5 ft (2m)
Video board for Model 9000-INT

5 BNC to 5 BNC (workstations) 6.5 ft (2m)

HD 15 to 5 BNC (VESA) 6.5 ft (2m)

MiniDin4 to MiniDin4 S-Video 6.5 ft (2m)

S-Video Cable 30 ft (9.2m)

SGI/SUN Workstation cables

Macintosh adapter

Kensington MicroSaver Security System

Rhapsody II Speakers

JBL Subwoofer

Portable Projector Stand

Insta-Theater High Power Screen

Ceiling Mount-LiteMount

LiteMount False Ceiling Plate



LiteMount Pipe Tubing Extension

CablePro Wall Plate

Executive Remote Control

Executive Remote IR Receiver

Portable and Laptop Activation Chart

Many laptop computers do not automatically turn on their external video port when a secondary display device such as a projector is connected. Activation commands for some laptop computers are listed in the following table. (If your computer is not listed or the given command does not work, refer to the computer's documentation for the appropriate command.) On some laptops, the activation function key is labeled with an icon, for example / or the text CRT/LCD.

Computer	Key command to activate port	Key command to de-activate port
Acer	Ctrl-Alt-Esc (for setup)	Ctrl-Alt-Esc (for setup)
AST* **	FN-D or Ctrl-D Ctrl-FN-D FN-F5 type from A:/VGA/CRT FN-F12	FN-D or Ctrl-D Ctrl-FN-D FN-F5 type from A:/VGA/CRT FN-F12
Advanced Logic Research	Ctrl-Alt-V	Ctrl-Alt-V
Altima	Shift-Ctrl-Alt-C setup VGA/ Conf.Simulscan	Shift-Ctrl-Alt-L setup VGA/ Conf.Simulscan
Ambra**	FN-F12 FN-F5 F2/Choose Option/F5	FN-F12 FN-F5 F2/Choose Option/F5
Amrel* **	setup menu Shift-Ctrl-D	setup menu Shift-Ctrl-D
Apple	see Mac Portable and Mac PowerBook	
Aspen	automatic	automatic
BCC*	automatic	reboot computer
Bondwell	LCD or CRT options after bootup	reboot for LCD or CRT options to appear
Chaplet**	setup screen FN-F6 FN-F4	setup screen FN-F6 FN-F4
Commax	Ctrl-Alt-#6	Ctrl-Alt-#5



NOTE: Often, pressing the key commands once activates the external video port, pressing it again activates both the external and internal ports, and pressing it a third time activates the internal port. Refer to your computer's documentation for details on your specific model.

Computer	Key command to activate port	Key command to de-activate port
Compaq* **	Ctrl-Alt-< FN-F4 automatic mode/? (for setup option)	Ctrl-Alt-> FN-F4 automatic mode/? (for setup option)
Compuadd* **	automatic Alt-F for screen setup option	automatic Alt-F for screen setup option
Data General	Ctrl-Alt-Command	Ctrl-Alt-Command
Data General Walkabout	2 CRT/X at DOS prompt	reboot
Datavue	Ctrl-Shift-M	Ctrl-Shift-M
Dell**	Ctrl-Alt-< Ctrl-Alt-F10 FN-F8 (CRT/LCD) FN-D FN-F12	Ctrl-Alt-> Ctrl-Alt-F10 FN-F8 FN-D FN-F12
Digital*	automatic FN-F2	reboot FN-F2
Dolch	dip switch to CRT	dip switch to LCD
Epson	dip switch to CRT	dip switch to LCD
Everex*	setup screen option	setup screen option
For-A	Ctrl-Alt-Shift-C	Ctrl-Shift-Alt-L
Gateway	FN-F1/FN-F1 again simultaneous	FN-F1
Grid* **	FN-F2, choose auto or simultaneous Ctrl-Alt-Tab	FN-F2 Ctrl-Alt-Tab
Hyundai	setup screen option	setup screen option
IBM 970*	automatic	warm reboot

Computer	Key command to activate port	Key command to de-activate port
IBM ThinkPad**	reboot, enter setup menu FN-F7, select choice from setup menu FN-F1, select choice FN-F5, select choice PS/2 SC select choice (CRT, LCD, etc.)	FN-F2
Kaypro	boot up, monitor plugged in	unplug monitor
Kris Tech	FN-F8	FN-F8
Mac Portable 100	no video port: not compatible	
Mac PowerBook		
140, 145, 150, 170	no video port: requires a 3rd-party interface	
160, 165, 180, 520, 540, 5300, 1400, 3400, G3	Control Panel folder; PowerBook Display folder; Activate Video Mirroring or select SimulScan Mode	warm reboot
210, 230, 250, 270, 280, 2300	requires Apple Docking Station or Mini Dock	
Magitronic	FN-F4	FN-F4
Mastersport	FN-F2	FN-F1
Micro Express*	automatic	warm reboot
Microslate*	automatic	warm reboot
Mitsubishi	SW2 On-Off-Off-Off	SW2 Off-On-On-On
NCR	setup screen option	setup screen option
NEC* **	setup screen option CRT at the DOS prompt FN-F3I	setup screen option LCD at the DOS prompt FN-F3
Olivetti**	automatic FN-O/* FN-	automatic FN-O/* FN-

Computer	Key command to activate port	Key command to de-activate port
Packard Bell**	FN-F2 Ctrl-Alt-<	FN-F2 Ctrl-Alt->
Panasonic	FN-F2	FN-F2
Samsung*	setup screen option	setup screen option
Sanyo	setup screen option	setup screen option
Sharp	dip switch to CRT	dip switch to LCD
Sun SPARC-Dataview	Ctrl-Shift-M	Ctrl-Shift-M
Tandy**	Ctrl-Alt-Insert setup screen option	Ctrl-Alt-Insert setup screen option
Texas Instruments*	setup screen option	setup screen option
Top-Link* **	setup screen option FN-F6	setup screen option FN-F6
Toshiba* **	Ctrl-Alt-End FN-End FN-F5 setup screen option	Ctrl-Alt-Home FN-Home FN-F5 setup screen option
Twinhead*	FN-F7 FN-F5 Automatic	FN-F7 FN-F5 Automatic
WinBook	Ctrl-Alt-F10	Ctrl-Alt-F10
Wyse	software driven	software driven
Zenith**	FN-F10 FN-F2 FN-F1	FN-F10 FN-F2 FN-F1

* These manufacturers have models that automatically send video to the external CRT port when some type of display device is attached.

** These manufacturers offer more than one key command depending on the computer model.

Using Video Mirroring with a PowerBook Computer

When you turn video mirroring (called SimulScan in newer PowerBooks—see below) on, the projector displays the same information that appears on your PowerBook's built-in screen. When video mirroring is off, the projector acts like a separate display.

To turn on video mirroring for the first time:

- 1 Open the Monitors control panel; click on Monitor 2.
- 2 Set the number of colors you want.
- 3 Open the Control Strip; click on the monitor icon.
- 4 Select "Turn Video Mirroring On."

Now you can turn video mirroring on and off from the Control Strip without having to open the Monitors control panel again.

When using video mirroring and high color graphics such as slide shows, the projected image occasionally might turn black and white. If this happens, perform the following steps:

- 1 Turn off video mirroring.
- 2 Open the Monitors control panel.
- 3 Move the white menu bar to Monitor 2 to set the projector as the primary monitor.
- 4 Restart the PowerBook.

Using SimulScan

Some newer PowerBooks display images on an external monitor or projector differently than previous ones. When using SimulScan, the projector displays the same information that appears on your PowerBook

To select SimulScan:

- 1 Open the Control Panel, then double-click Monitors and Sound.
- 2 In the Resolution list, choose the SimulScan mode, then click OK.
- 3 If this changes your display settings, a dialog box appears. Click OK to confirm the change.



Projected Image Size for Optional Lenses

NOTE: The lens shift is not adjustable on the optional short throw lens. It is fixed at zero degrees.

*Table 4:
Diagonal Image Size and Width vs Distance to Screen-
Long Throw and Short Throw Lenses*

Diagonal Image Size (inches)	Image Width (inches)	Distance to screen	
		Long Throw (feet)	Short Throw (feet)
300	240	100	N/A
240	192	80	N/A
180	144	60	N/A
144	115	48	11.5
120	96	40	9.6
96	77	32	7.7
72	58	24	5.8
60	48	20	4.8
48	38	N/A	3.8

The formulas for distance to the screen are:

Long throw lens distance (ft) = diagonal image size (ft) ÷ .25

Short throw lens distance (ft) = diagonal image size (ft) ÷ 1.042

Connection Pin Assignments

HD 15

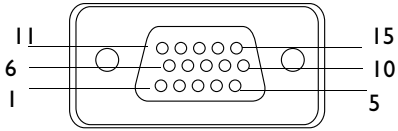

1. Video input (red)	9. Unused
2. Video input (green)	10. Ground
3. Video input (blue)	11. Unused
4. Unused	12. DDC data
5. Ground	13. Horizontal sync signal
6. Ground (red)	14. Vertical sync signal
7. Ground (green)	15. DDC clock
8. Ground (blue)	

5 BNC

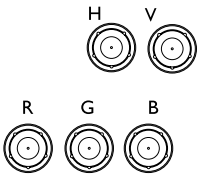

R	Video input (red)
G	Video input (green)
B	Video input (blue)
H	Horizontal sync signal
V	Vertical sync signal

RS-232

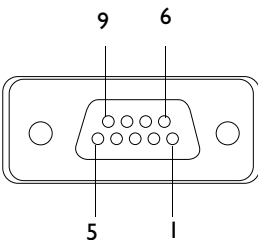

1. Not used	6. Not used
2. Receive data	7. Not used
3. Send data	8. Not used
4. Not used	9. Not used
5. Ground	



NOTE: Pin assignments are not available for the CablePro connector.



NOTE: For model 9000-INT: To use video input, an optional video board must be installed in the projector. Contact Boxlight for more information.



NOTE: When all 5 BNCs are connected, the projector handles separate sync on H and V. When 4 BNCs are connected, the projector handles a combined sync on H. When 3 BNCs are connected, the projector handles a combined sync on G.

S-video

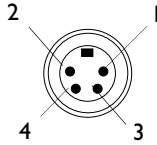

1. Ground	3. luminance
2. Ground	4. Chrominance



NOTE: For model 9000-INT: To use video input, an optional video board must be installed in the projector. Contact Boxlight for more information.

Wired remote

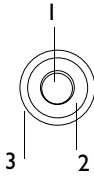

1. (inner circle) Ground	3. (outer circle) Remote power
2. (second circle) Data	

RS232 Terminal Specifications

Communication configuration

To control the projector from an LCD control panel, connect the RS232 cable and set your computer's serial port settings to match this communication configuration:

Setting	Value
Bits per second	19,200
Data bits	8
Parity	None
Stop bits	1
Flow control	None
Emulation	VT100

Command format

All commands consist of 3 alpha characters followed by a request, all enclosed in parentheses. The request can be a read request (indicated by a "?") or a write request (indicated by 1 to 4 ASCII digits).

A read request format: (AAA?) where

- (starts the command
- AAA denotes the command
- ? denotes the read request
-) ends the command

A read command returns the range and the current setting, for example:

Function	Command	Response
Brightness	(BRT?)	(0-22, 10)
Volume	(VOL?)	(0-80, 0)
Lamp hours	(LMP?)	(0-9999, 421)

A write request example: (AAA####) where

- (starts the command
- AAA denotes the command
- #### denotes the value to be written (leading zeros not necessary)
-) ends the command



NOTE: To assure the projector can process a command, wait 3 seconds before entering the next command.

Some commands have ranges, while others are absolute. If a number greater than the maximum range is received, it is automatically set to the maximum number for that function. If a command is received that is not understood, a “?” is returned. With absolute settings, “0” is off, 1-9999 is on. The one exception is the Power command, where 0 is off and 1 is on.

Function	Command	Response
Brightness	(BRT10)	Sets the brightness to 10
Freeze	(FRZ1) or (FRZ8888)	Freezes the display
Power	(PWR0)	Turns power off
Power	(PWR1)	Turns power on
Power	(PWR9999)	?

Supported commands

Function	Command	Range
Power (Write only)	PWR	0-1
Lamp Hours (Read only)	LMP	0-9999
Standby	STB	0-1
Freeze	FRZ	0-1
Brightness	BRT	0-255
Contrast	CON	0-255 (0-127 for video)
Tint	TNT	0-255 (0-63 for video)
Saturation	CLR	0-63

Reset All	RST	0-1
Auto Source Select Control	ASC	0-1
Default Source	DSC	0-4 0 = Computer 1 1 = Computer 2 2 = Computer 3 3 = Video 1 4 = Video 2
Source	SRC	0-4 (same designations as Default Source)
Volume	VOL	0-80
Mute	MTE	0-1
Balance	BAL	0-63
Fade	FAD	0-63
Treble	TRB	0-14
Bass	BAS	0-14
Auto Image	AIM	0-1
Auto Resize	ARZ	0-1
Manual Sync Setting	MSS	0-19
Manual Tracking Setting	MTS	0-63
Horizontal Position Setting	HPS	0-63
Vertical Position Setting	VPS	0-63
Video Standard	VSU	0-4 0 = Auto 1 = NTSC 2 = PAL 3 = SECAM 4 = NTSC4.43
Language	LAN	0-3 0 = English 1 = French 2 = German 3 = Spanish
Ceiling	CEL	0-1
Rear Project	REA	0-1

INDEX

A

- accessories, ordering 47, 49, 58
- activation commands for laptop computers 49
- adjusting
 - balance 29
 - bass 30
 - color 28
 - contrast 27
 - fade 30
 - Menu Position 28
 - tint 27
 - treble 30
 - volume 25, 29
- altitude limits 45
- annotating 24
- assistance. See Technical Support
- Audio menu 29
- Audio menu options
 - Balance 29
 - Bass 30
 - Fade 30
 - Treble 30
 - Volume 29
- Auto Source Select 34

B

- balance, adjusting 29
- bass, adjusting 30
- Blank Screen 28
- Boxlight 9000
 - cases 47
 - ceiling mounted 5, 34
 - hot surfaces iv
 - project from behind the screen 34
 - setting up 5
 - specifications 45
 - turning off 17
 - turning on 16
 - ventilation and overheating iv
 - voiding the warranty iv
- brightness, adjusting 27

buttons on remote

- Computer 23
- Freeze 23
- Help 23
- Light 23
- Menu 23
- Mute 23
- Power 24
- Scribble 24
- Video 24
- Volume 25

C

- CablePro
 - connecting to equipment 9
 - extension cable 47
- cables
 - A/V 14
 - CablePro extension 47
 - composite video 14
 - extension 47
 - ordering 47, 49, 58
 - power iii, 47
 - remote control 16, 47
 - S-video 14, 48
- cases, ordering 47
- ceiling-mounted projection 34, 47
- cleaning the projection lens 35
- color, adjusting 28
- colors
 - don't match monitor colors 43
 - not displayed 40
- compatibility
 - IBM-compatible 1
 - Macintosh 1
- composite video cable
 - connecting 14
- Computer button 23
- computers, compatible 1

- connecting
 - external speakers 15
 - IBM-compatible computer 11
 - Macintosh computers 12
 - power cord 16
 - remote control cable 16
 - video player 14–15
- connector panel
 - audio out 15
 - remote cable 16
- contrast, adjusting 27
- Controls menu 33
- Controls menu options
 - Auto Source Select 34
 - Ceiling 34
 - Default Source 34
 - Language 34
 - Rear Projection 34
 - Standby Time 33
 - Video Standard 33
- cords. See cables

D

- Default Source 34
- Display menu 27
- Display menu options
 - Blank Screen 28
 - Brightness 27
 - Color 28
 - Contrast 27
 - Menu Position 28
 - Reset All 28
 - Tint 27
- displaying
 - online help information 23
 - on-screen menus 23

E

- extension cable 47
- external speakers, connecting 15

F

- fade, adjusting 30
- filter, cleaning 35
- Freeze button 23
- freezing the display 23
- fuzzy lines 32

H

- Help button 23
- hot surfaces iv

I

- IBM-compatible computers
 - compatibility 1
 - connecting 11
- icons
 - on projector labels iii
 - on the projector 10
- image
 - adjusting 16, 19
 - centering 19
 - colors don't match computer's 43
 - focusing 20
 - fuzzy lines 19, 32
 - has lines or spots 42
 - not centered 40
 - not displayed 40
 - out of focus 42
 - quality iv, 40–43
 - resolution 1
 - reversed 42
 - size 5, 54
 - streaked 42
 - too wide or too narrow 19, 41
- Image menu 31
- Image menu options
 - Auto Image 31
 - Auto Resize 31
 - Horiz. Position 32
 - Manual Sync 32
 - Manual Tracking 32
 - Vert. Position 32
- intake filter, cleaning 35

K

Kensington lock 39, 48
keypad, description of buttons 22

L

labels on projector iii
lamp
 ordering 47
 overheating iv
 replacing 37
 safety iii–iv
 turns off unexpectedly 43
lamp hour counter 26
lamp hour counter, resetting 38
language, selecting for menus 34
laptop computers
 activation sequence to allow
 secondary display 49
 compatibility 11
 connecting IBM-compatible 14
 connecting PowerBook 12
lens
 cap 47
 cleaning 35
 safety iii
leveling the projector 20
Light button 23

M

Macintosh computers
 adaptor 12
 compatibility 1
 connecting 12
Menu button 25
Menu Position 28
menus. See on-screen menus
monitor, projected colors don't match
 43
Mute button 23

N

NTSC video 33

O

on-screen menus
 Audio menu 29
 changing language of 34
 Controls menu 33
 Display menu 27
 displaying 25
 Image menu 31
 making changes to menu
 functions 25
 removing from the screen 26

P

PAL video 33
power cord
 connecting 16
 grounding iv
 ordering 47
 safety iii
power source, safety iii
power strip 16
power up sequence 17, 41
project from behind the screen 34

R

rear projection 34
remote control
 description of buttons 22
 illuminating buttons 23
 not working 43
 ordering 47
 replacing the batteries 39
 specifications 45
 using 21
repair. See Technical Support
replacing
 projection lamp module 37
re-positioning the image on the screen
 32
resetting adjustments 28
resetting lamp hour counter 38
resolution 1

S

- safety guidelines iii–iv
- Scribble button 24
- SECAM video 33
- security feature 39
- service. See Technical Support
- SimulScan, using with PowerBooks 53
- speakers
 - external 23, 48
 - internal 23
 - muting 23
- specifications 45
- Standby Time 33
- S-video
 - connecting 14
 - ordering cable 48

T

- Technical Support
 - information to have on hand before you call 44
 - voiding the warranty iv
- temperature limits 45
- test pattern 41
- text not visible 40
- tint, adjusting 27
- treble, adjusting 30
- troubleshooting 40
- turning off
 - projector 17
 - sound 23
- turning on the projector 16

U

- using the remote control 21

V

- vertical lines displayed 32, 42
- Video button 24
- video mirroring on a PowerBook 12, 53
- video standards 33
- volume
 - adjusting 25, 29
 - muting 23
- Volume buttons 25

W

- warranty iv, 48

LIMITED WARRANTY

Boxlight Corporation ("Boxlight") warrants that each Boxlight 9000 ("the Product") sold hereunder will conform to and function in accordance with the written specifications of Boxlight. Said limited warranty shall apply only to the first person or entity that purchases the Product for personal or business use and not for the purpose of distribution or resale. The product may contain recycled components that are in new condition. Said warranty shall continue for a period of one (1) year from the date of such purchase. The standard limited warranty excludes the lamps in projectors after 90 days. Boxlight does not warrant that the Product will meet the specific requirements of the first person or entity that purchases the Product for personal or business use. Boxlight's liability for the breach of the foregoing limited warranty is limited to the repair or replacement of the Product or refund of the purchase price of the Product, at Boxlight's sole option. To exercise the Purchaser's rights under the foregoing warranty, the Product must be returned at the Purchaser's sole cost and expense, to Boxlight or to any authorized Boxlight service center provided, however, that the Product must be accompanied by a written letter explaining the problem and which includes (i) proof of date of purchase; (ii) the dealer's name; and (iii) the model and serial number of the Product. A return authorization number, issued by the Boxlight customer service department, must also be clearly displayed on the outside of the shipping carton containing the Product.

WARRANTY LIMITATION AND EXCLUSION

Boxlight shall have no further obligation under the foregoing limited warranty if the Product has been damaged due to abuse, misuse, neglect, accident, unusual physical or electrical stress, unauthorized modifications, tampering, alterations, or service other than by Boxlight or its authorized agents, causes other than from ordinary use or failure to properly use the Product in the application for which said Product is intended.

DISCLAIMER OF UNSTATED WARRANTIES

THE WARRANTY PRINTED ABOVE IS THE ONLY WARRANTY APPLICABLE TO THIS PURCHASE. ALL OTHER WARRANTIES, EXPRESS OR IMPLIED, INCLUDING, BUT NOT LIMITED TO, THE IMPLIED WARRANTIES OF MERCHANTABILITY AND FITNESS FOR A PARTICULAR PURPOSE ARE DISCLAIMED. THERE ARE NO WARRANTIES THAT EXTEND BEYOND THE FACE HEREOF AND THE FOREGOING WARRANTY SHALL NOT BE EXTENDED, ALTERED OR VARIED EXCEPT BY WRITTEN INSTRUMENT SIGNED BY BOXLIGHT.

LIMITATION OF LIABILITY

IT IS UNDERSTOOD AND AGREED THAT BOXLIGHT'S LIABILITY WHETHER IN CONTRACT, IN TORT, UNDER ANY WARRANTY, IN NEGLIGENCE OR OTHERWISE SHALL NOT EXCEED THE RETURN OF THE AMOUNT OF THE PURCHASE PRICE PAID BY PURCHASER AND UNDER NO CIRCUMSTANCES SHALL BOXLIGHT BE LIABLE FOR SPECIAL, INDIRECT OR CONSEQUENTIAL DAMAGES OR LOST PROFITS, LOST REVENUES OR LOST SAVINGS. THE PRICE STATED FOR THE PRODUCT IS A CONSIDERATION IN LIMITING BOXLIGHT'S LIABILITY. NO ACTION, REGARDLESS OF FORM, ARISING OUT OF THE AGREEMENT TO PURCHASE THE PRODUCT MAY BE BROUGHT BY PURCHASER MORE THAN ONE YEAR AFTER THE CAUSE OF ACTION HAS ACCRUED.

Part Number 010-0166-00