

# INTRODUCTION

This equipment will brew one or two half-gallon batches of coffee simultaneously into awaiting dispensers with just the press of a button. One side may include a hot water faucet for allied beverage use. Most functions of the brewer are digitally controlled. It is only for indoor use on a sturdy counter or shelf.

## CONTENTS

Introduction & Warranty .....	2
User Notices .....	3
Electrical & Plumbing Requirements .....	4
Operating Controls .....	5
Initial Set-Up, Coffee Brewing, & Cleaning .....	6
Adjustments & Optional Settings .....	7
Adjusting Brew Volumes & Water Sensing Threshold Adjustment .....	8
Pulse Brew Setup Procedure .....	9
Troubleshooting .....	10
Diagnostics .....	20
Service .....	21
Wiring Diagrams .....	30

## BUNN-O-MATIC COMMERCIAL PRODUCT WARRANTY

Bunn-O-Matic Corp. ("BUNN") warrants equipment manufactured by it as follows:

- 1) All equipment other than as specified below: 2 years parts and 1 year labor.
- 2) Electronic circuit and/or control boards: parts and labor for 3 years.
- 3) Compressors on refrigeration equipment: 5 years parts and 1 year labor.
- 4) Grinding burrs on coffee grinding equipment to grind coffee to meet original factory screen sieve analysis: parts and labor for 3 years or 30,000 pounds of coffee, whichever comes first.

These warranty periods run from the date of installation BUNN warrants that the equipment manufactured by it will be commercially free of defects in material and workmanship existing at the time of manufacture and appearing within the applicable warranty period. This warranty does not apply to any equipment, component or part that was not manufactured by BUNN or that, in BUNN's judgment, has been affected by misuse, neglect, alteration, improper installation or operation, improper maintenance or repair, damage or casualty. This warranty is conditioned on the Buyer 1) giving BUNN prompt notice of any claim to be made under this warranty by telephone at (217) 529-6601 or by writing to Post Office Box 3227, Springfield, Illinois 62708-3227; 2) if requested by BUNN, shipping the defective equipment prepaid to an authorized BUNN service location; and 3) receiving prior authorization from BUNN that the defective equipment is under warranty.

**THE FOREGOING WARRANTY IS EXCLUSIVE AND IS IN LIEU OF ANY OTHER WARRANTY, WRITTEN OR ORAL, EXPRESS OR IMPLIED, INCLUDING, BUT NOT LIMITED TO, ANY IMPLIED WARRANTY OF EITHER MERCHANTABILITY OR FITNESS FOR A PARTICULAR PURPOSE.** The agents, dealers or employees of BUNN are not authorized to make modifications to this warranty or to make additional warranties that are binding on BUNN. Accordingly, statements by such individuals, whether oral or written, do not constitute warranties and should not be relied upon.

If BUNN determines in its sole discretion that the equipment does not conform to the warranty, BUNN, at its exclusive option while the equipment is under warranty, shall either 1) provide at no charge replacement parts and/or labor (during the applicable parts and labor warranty periods specified above) to repair the defective components, provided that this repair is done by a BUNN Authorized Service Representative; or 2) shall replace the equipment or refund the purchase price for the equipment.

**THE BUYER'S REMEDY AGAINST BUNN FOR THE BREACH OF ANY OBLIGATION ARISING OUT OF THE SALE OF THIS EQUIPMENT, WHETHER DERIVED FROM WARRANTY OR OTHERWISE, SHALL BE LIMITED, AT BUNN'S SOLE OPTION AS SPECIFIED HEREIN, TO REPAIR, REPLACEMENT OR REFUND.**

In no event shall BUNN be liable for any other damage or loss, including, but not limited to, lost profits, lost sales, loss of use of equipment, claims of Buyer's customers, cost of capital, cost of down time, cost of substitute equipment, facilities or services, or any other special, incidental or consequential damages.

BUNN, CDBC TWIN, and CDBC F TWIN are either trademarks or registered trademarks of Bunn-O-Matic Corporation.

## USER NOTICES

Carefully read and follow all notices in this manual and on the equipment. All labels on the equipment should be kept in good condition. Replace any unreadable or damaged labels.

# 00986.0000



# 03408.0002



# 03409.0002



# 00656.0000



# 00658.0000



# 29007.0000

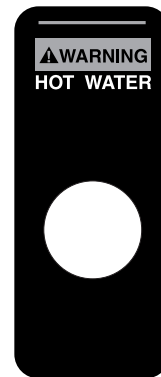

# 12364.0000



# 10044.0000

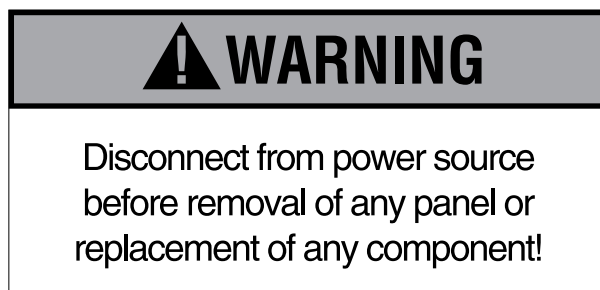

## ELECTRICAL REQUIREMENTS

**CAUTION** - The brewer must be disconnected from the power source until specified in *Initial Set-Up*.

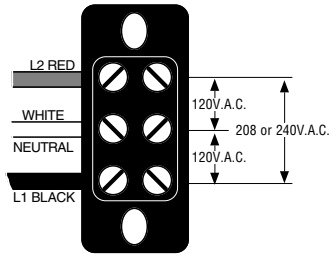

One circuit models require one 3-wire, grounded service rated 120/208 or 120/240 volts ac, 40 amp, single phase, 60 Hz.

Two circuit models require two 3-wire, grounded service rated 120/208 or 120/240 volts ac, 20 amp, single phase, 60 Hz.

Proceed as follows:

### Electrical Hook-Up

**CAUTION** – Improper electrical installation will damage electronic components.

1. An electrician must provide electrical service as specified.
2. Using a voltmeter, check the voltage and color coding of each conductor at the electrical source.
3. Remove the front panel beneath the sprayhead.
4. Feed the cord through the strain relief and connect it to the terminal block(s).
5. Connect the brewer to the power source and verify the voltage at the terminal block(s) before proceeding. Replace the front panel.
6. If plumbing is to be hooked up later be sure the brewer is disconnected from the power source. If plumbing has been hooked up, the brewer is ready for Initial Set-Up.

## PLUMBING REQUIREMENTS

These brewers must be connected to a cold water system with operating pressure between 5 and 90 psi (34.5 and 620 kPa) for CDBC models. A shut-off valve should be installed in the line before the brewer. Install a regulator in the line when pressure is greater than 90 psi (620 kPa) to reduce it to 50 psi (345 kPa). The water inlet fitting is  $\frac{3}{8}$ " flare. Bunn-O-Matic does not recommend the use of a reverse-osmosis or deionized water supply to this equipment.

**NOTE** - Bunn-O-Matic recommends  $\frac{3}{8}$ " copper tubing from a  $\frac{1}{2}$ " or larger water supply line. A tight coil of copper tubing in the water line will facilitate moving the brewer to clean the countertop. Bunn-O-Matic does not recommend the use of a saddle valve to install the brewer. The size and shape of the hole made in the supply line by this type of device may restrict water flow.

**This equipment must be installed to comply with the Basic Plumbing Code of the Building Officials and Code Administrators International, Inc. (BOCA) and the Food Service Sanitation Manual of the Food and Drug Administration (FDA).**

### Plumbing Hook-Up

1. Flush the water line.
2. Securely attach it to the flare fitting at the rear of the brewer.
3. Turn on the water supply.

# OPERATING CONTROLS

## Model CDBC TWIN

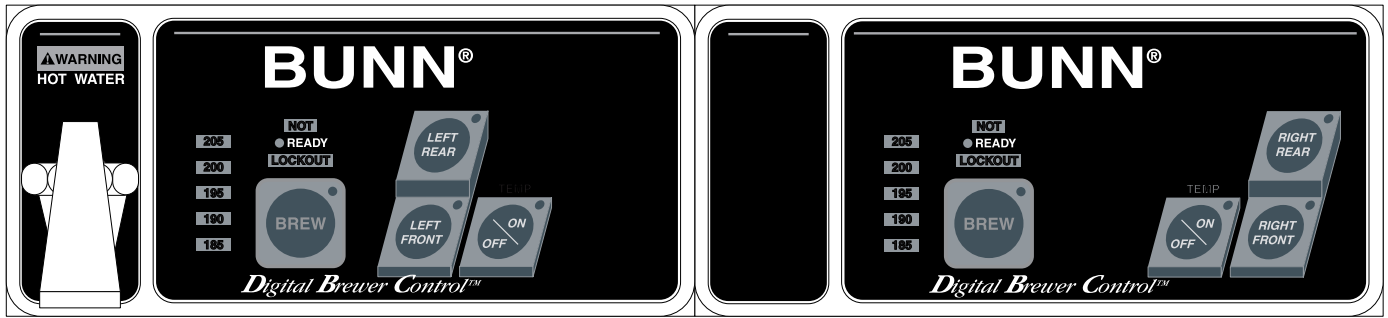

### ON/OFF SWITCH

P1869

Pressing the "ON/OFF" switch (indicator glowing) supplies power to the brew station warmer, enables the brew circuit, and energizes the tank refill circuit. Pressing the switch again (indicator not glowing) stops tank refilling, brewing and deenergizes the brew station warmer. Stopping a brew cycle after it has been started will not stop the flow of water into the decanter/server until the funnel is empty.

**NOTE** – Hot water will be available at the faucet in a limited amount when the "ON/OFF" indicator is not glowing because the tank will not refill.

### BREW SWITCH

Momentarily pressing and releasing the switch starts a brew cycle when the "ON/OFF" indicator is glowing.

**NOTE** – The "ON/OFF" indicator must be glowing to initiate and complete a brew cycle.

### ADDITIONAL WARMER SWITCHES

Pressing any additional warmer switch so the indicator is glowing, supplies power to the associated warmer.

### READY INDICATOR

This indicator glows when the preset temperature has been achieved. The word "NOT" above "READY" will glow in all other instances.

## INITIAL SET-UP

1. Insert an empty funnel into the funnel rails of one of the brew stations.
2. Place an empty decanter/server under the funnel.
3. Connect the brewer to the power source.
4. Press the "ON/OFF" switch (indicator glowing).
5. Water will flow into the tank and stop when the tank is filled to its capacity.
6. Wait approximately twenty minutes for the water in the tank to heat to the proper temperature.
7. Place a small vessel beneath the faucet and open the faucet handle. Release it when you hear water once again flowing into the tank.
8. With the "ON/OFF" switch still in the "ON" position (indicator glowing), momentarily press and release the "BREW" switch.
9. Allow the cycle to finish and measure the amount of water in the decanter/server. It should be 64 ounces  $\pm$  2. Refer to the adjustments section of this manual should the volume need to be increased or decreased.

**NOTE:** Repeat steps 1 through 9 for the other brew station.

The brewer is now ready for use in accordance with the coffee brewing instructions below.

## COFFEE BREWING

1. Insert a BUNN® filter into the funnel.
2. Pour the fresh coffee into the filter and level the bed of grounds by gently shaking.
3. Slide the funnel into the funnel rails.
4. Place an empty decanter/server beneath the funnel.
5. Press the "ON/OFF" switch (indicator glowing), then momentarily press and release the "BREW" switch.
6. When brewing is completed, simply discard the grounds and filter.

## CLEANING

1. The use of a damp cloth rinsed in any mild, non-abrasive, liquid detergent is recommended for cleaning all surfaces on Bunn-O-Matic equipment.
2. Check and clean the sprayhead. The sprayhead holes must always remain open.

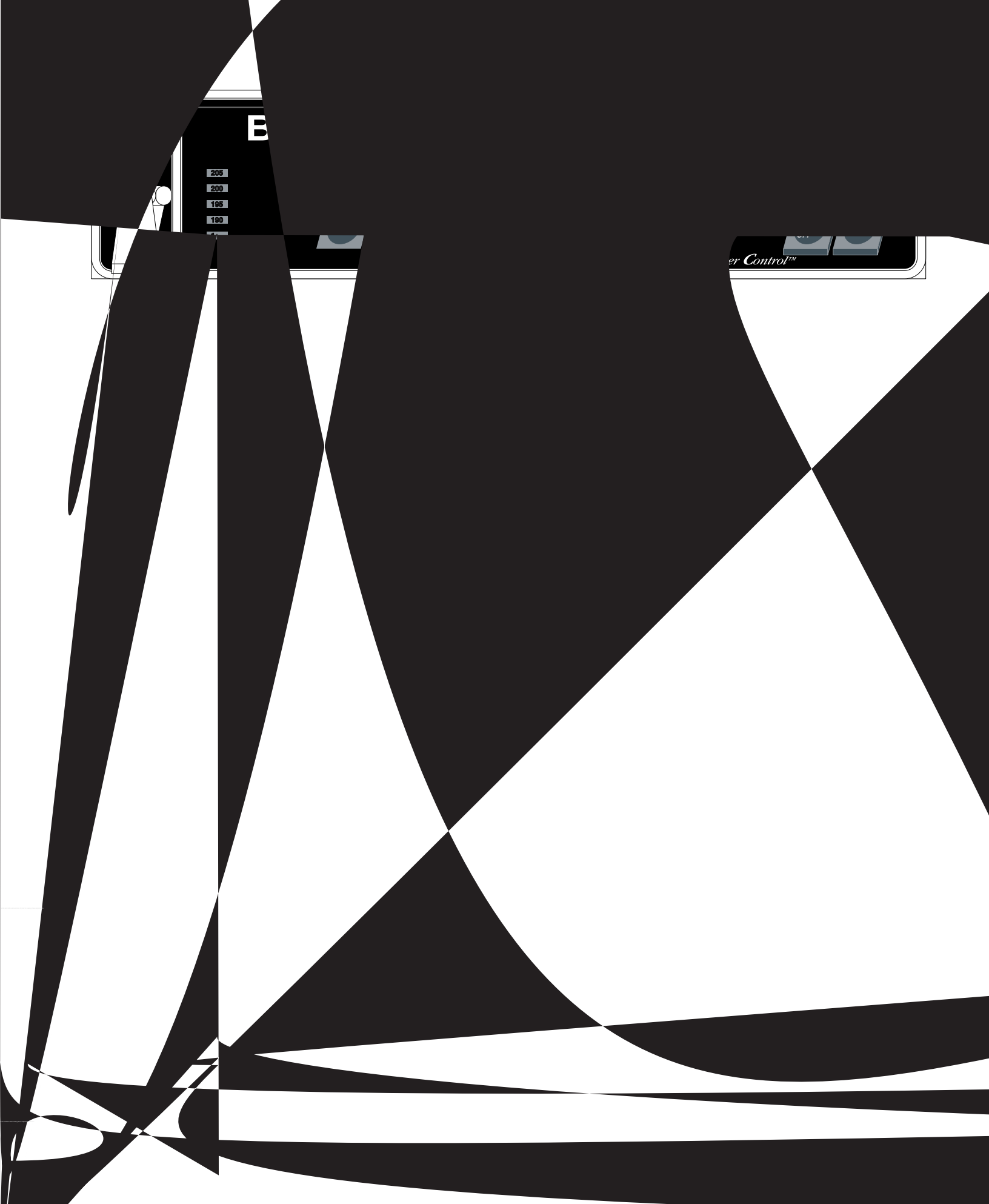

B

205

200

186

190

er Control™

## ADJUSTING BREW VOLUMES

The brewer is factory set to deliver 64 ounces  $\pm$  2 for each brew cycle.

**BREW VOLUME SET-UP:** Use the following steps when the setting is unknown or a different circuit board is being installed.

1. Place an empty funnel in the funnel rails and an empty decanter/server or graduated vessel beneath the funnel.
2. Press the "ON/OFF" switch (indicator glowing).
3. Press and hold the brew start button until you hear the brew solenoid click on-and-off three times (approximately 10 seconds). Release the button.
4. Allow the cycle to continue until the desired amount of water is dispensed and then turn "OFF" the brewer. The brewer is now set to dispense this amount of water for each subsequent brew cycle.

To **increase** the amount of water for each brew cycle place an empty funnel in the funnel rails and an empty decanter/server or graduated vessel beneath the funnel. Press the "ON/OFF" switch. Press and hold the "BREW" switch until you hear the solenoid click on-and-off three times (approximately 10 seconds), then release the "BREW" switch. Momentarily press and release the "BREW" switch once for each ounce (approximate) of water to be added to the prior setting and allow the brew cycle to finish.

To **decrease** the amount of water for each brew cycle place an empty funnel in the funnel rails and an empty decanter/server or graduated vessel beneath the funnel. Press the "ON/OFF" switch. Momentarily press and release the "BREW" switch once for each ounce (approximate) of water to be removed from the existing setting. Press and hold the "BREW" switch until you hear the solenoid click on-and-off three times (approximately 10 seconds), then release the "BREW" switch and allow the cycle to finish.

## WATER SENSING THRESHOLD ADJUSTMENT PROCEDURE

1. Make sure the tank is full of water to be used for calibration. The water must be in contact with the refill probe.
2. Unplug the brewer from the power source, then press and hold the BREW button while power is reapplied.
3. Continue pressing the BREW button until the READY indicator begins to flash. Release the BREW button and then press it again momentarily.
4. The new calibration is automatically completed within a few seconds. If the water is too pure for use with the brewer, the READY indicator will flash very rapidly and the old calibration will be retained.



## PULSE BREW SETUP PROCEDURE

The pulse brew parameters (initial fill time, off times, and remaining on times) are entered using the following set-by-example process.

1. First set the brew volume using the standard procedure in *Brew Volume Setup*.
2. Position an empty container under the sprayhead. Allow the tank to finish refilling. Make sure that the READY lamp is on, or that the BREW LOCKOUT function is turned off.
3. Press and hold the "ON/OFF" button. The brew valve will turn on after 10 seconds. Release the button. This begins the **initial on-time** setting. When the spray has continued for the desired time, momentarily press the "ON/OFF" button.
4. The spray is now stopped and the **off time** setting has begun. Press the "ON/OFF" button momentarily to end the **off time**.
5. The spray is now on again and the **remaining on time** setting has begun. Press the "ON/OFF" button momentarily at the end of the desired **remaining on time**.
6. The setup is now complete and the parameters are stored in memory. The spray will continue the off and on cycles until the brew volume of step 1 is complete. Pressing the "ON/OFF" button again will terminate the brewing cycle, with the parameters stored in memory.
7. If only a preinfusion is desired, i.e. an initial on time followed by one off period, use the same procedure, but stop after step 4 and allow the brew to finish the volume set in step 1. This will store the initial on time and off time in memory.

### Procedure for Disabling Pulse Brew or Preinfusion:

1. Position an empty container under the sprayhead. Allow the tank to finish refilling. Make sure that the READY lamp is on, or that the BREW LOCKOUT function is turned off.
2. Press and hold the "ON/OFF" button. The brew valve will turn on after 10 seconds. Release the button.
3. Allow the spray to continue and press no buttons until spray stops. The pulse and preinfusion functions are now disabled.

NOTE: When the brewer has been set up for pulse or preinfusion, the adjustment of brew volume is done the same as always and has no effect on the pulse brew parameters. The pulsing is temporarily disabled while adjusting the brew volume and automatically returns during normal brewing.

## TROUBLESHOOTING

A troubleshooting guide is provided to suggest probable causes and remedies for the most likely problems encountered. If the problem remains after exhausting the troubleshooting steps, contact the Bunn-O-Matic Technical Service Department.

- Inspection, testing, and repair of electrical equipment should be performed only by qualified service personnel.
- All electronic components have 120 volt ac and low voltage dc potential on their terminals. Shorting of terminals or the application of external voltages may result in board failure.
- Intermittent operation of electronic circuit boards is unlikely. Board failure will normally be permanent. If an intermittent condition is encountered, the cause will likely be a switch contact or a loose connection at a terminal or crimp.
- Solenoid removal requires interrupting the water supply to the valve. Damage may result if solenoids are energized for more than ten minutes without a supply of water.
- The use of two wrenches is recommended whenever plumbing fittings are tightened or loosened. This will help to avoid twists and kinks in the tubing.
- Make certain that all plumbing connections are sealed and electrical connections tight and isolated.
- This brewer is heated at all times. Keep away from combustibles.

- WARNING** –
- Exercise extreme caution when servicing electrical equipment.
  - Unplug the brewer when servicing, except when electrical tests are specified.
  - Follow recommended service procedures.
  - Replace all protective shields or safety notices.

### ***Before troubleshooting this brewer, check for the following:***

#### A. Control Boards

Make sure ribbon cable is properly attached to the control board (ALL PINS INSERTED INTO PLUG).

Make sure there is a nylon insulating washer under each screw head that holds the control board to the plastic front end cap. This is important for proper operation.

#### B. Make sure before servicing brewer that voltage is present at control board.

Press any warmer switch or observe if any indicator lights are glowing on the control panel. If so, proceed with testing. If not, check for voltage across pins 1 & 2 of the ten pin J1 connector (black and white wires). If voltage is present, replace the control board. If voltage is not present, check wiring and voltage across terminal block(s) (black and white). Correct the problem and retest before proceeding with testing.

## TROUBLESHOOTING (cont.)

### REFILL CIRCUIT

#### PROBLEM

#### PROBABLE CAUSE

#### REMEDY

Will not fill or refill

1. Power off to brewer

Press ON/OFF switch on control panel to determine if power is "ON".

2. Water shut off

Make sure water is ON.

3. Display flashing

Brewer has shut down due to malfunction (See Diagnostic Chart in manual, Page 20, or under top lid of brewer).

4. ON/OFF Switch

Make sure ON/OFF Switch is "ON" and indicator is lit.

5. Lime build up on Probe

Remove the Probe and check for lime deposit on tip. Clean and reinstall.

6. Refill Valve or Control Board

Disconnect the brewer from the power source and remove wires from refill valve coil. Check for continuity across the terminals of the solenoid coil. If continuity is not present, replace the refill valve (See page 28). If continuity is present, the coil may be stuck closed. Shut water off to brewer. Set the ON/OFF switch to the "OFF" position. Open the faucet and drain water down in the tank until flow stops or slows to a trickle. Attach a voltmeter to the terminals of the refill solenoid. Connect the brewer to the power source. Press the switch "ON". Within five seconds, voltage should be present at the solenoid terminals. If voltage is not present, refer to the wiring diagrams and check the wiring harness.

7. Water is too conductive for proper operation when using the factory setting of sensing threshold

Reset the *Water Sensing Threshold Adjustment Procedures* on page 8.

Fill or refill does not shut "OFF" (ON/OFF Switch "ON")

1. Lime build up on probe

Remove Probe and check for lime deposits on tip. Clean and reinstall.

## TROUBLESHOOTING (cont.)

### REFILL CIRCUIT (cont.)

#### PROBLEM

---

#### PROBABLE CAUSE

---

#### REMEDY

---

	2. Water Level Probe Sensing System	Disconnect the brewer from the power source. Disconnect the J3 connector from the control board. Check for continuity from the nut on top of the level probe to pin 1 of the plug, continuity should be present. Pull the temperature probe up about an inch from the grommet. Check for continuity from the outside surface of the temperature probe and pin 4 of the plug, continuity should be present. Connect the J3 plug to the control board and proceed to step 3.
	3. Refill valve or control board	Press ON/OFF switch to "ON" (Indicator lamp should be lit). If water continuously flows out of air vent tube, disconnect the brewer from the power source. If water flow stops, replace the control board. (See page 22) If water flow does not stop, repair or replace the refill solenoid. (See page 28)
	4. Water is too conductive for proper operation when using the factory setting of sensing threshold.	Reset the <i>Water Sensing Threshold Adjustment Procedures</i> on page 9.
Fill or refill does not shut "OFF" (ON/OFF Switch "OFF")	1. Refill valve or control board	If water continuously flows out of air vent tube, disconnect the brewer from the power source. If water flow does not stop, repair or replace the refill solenoid. (See page 28) If the valve closes when power is removed, replace the control board. (See page 22)

## TROUBLESHOOTING (cont.)

### HEATING CIRCUIT

#### PROBLEM

---

Water does not heat to proper temperature

**IMPORTANT:** Make sure no temperature tests are taken before the ready light is "ON". Tank temperature must be stabilized before readings are taken.

#### PROBABLE CAUSE

---

1. Display flashing
  
2. Water not touching temperature probe
  
3. Dry Plug In Probe Sensing System

#### REMEDY

---

Brewer has shut down due to malfunction (See Diagnostic Chart in manual, Page 20, or under top lid).

Remove probe and grommet. Look into hole on tank lid. Water must be within one inch from top of tank.

Disconnect the brewer from the power source. Disconnect the J3 connector from the control board. Check for continuity from the tank mounting screw where the green wire mounts, to pin 2 of the plug, continuity should be present. Pull the temperature probe up about an inch from the grommet. Check for continuity from the outside surface of the temperature probe and pin 4 of the plug, continuity should be present. Connect the J3 plug to the control board and proceed to step 4.

## TROUBLESHOOTING (cont.)

### HEATING CIRCUIT

#### PROBLEM

---

Water does not heat to proper temperature (cont.)

**IMPORTANT:** Make sure no temperature tests are taken before the ready light is "ON". Tank temperature must be stabilized before readings are taken.

#### PROBABLE CAUSE

---

4. Temperature Probe

5. Limit Thermostat

6. Tank Heater

1. Lime build up on temperature probe, tank or tank heater

#### REMEDY

---

Remove the probe from the grommet and submerge in a water bath of approximately 70°F(21°C). Connect an ohmmeter to pins 3 and 4 of the J3 connector. At 60°F(16°C) the reading should be 15.3k ± 2k OHMS, at 70°F(21°C) the reading should be 11.8k ± 2k OHMS, and at 80°F(27°C) the reading should be 9.3k ± 2k OHMS. If the probe is within these parameters, reconnect the J3 plug to the control board.

Disconnect the brewer from the power source. Check for continuity across the limit thermostat terminals. Continuity should be present. If not replace the limit thermostat. (See page 25)

Disconnect the brewer from the power source. Check for continuity between the white terminal of the terminal block and the black wire on the relay on the control board. There should be a low OHM reading. If no continuity is present, check for a wiring problem, then replace the tank heater if no wiring problem is found. (See page 26)

Inspect probe and tank assembly for excessive lime deposits. Delime as required.

Spitting or excessive steaming

## TROUBLESHOOTING (cont.)

### HEATING CIRCUIT

<b>PROBLEM</b>	<b>PROBABLE CAUSE</b>	<b>REMEDY</b>
Spitting or excessive steaming (cont.)	2. Temperature Probe	Remove the probe from the grommet and submerge in a water bath of approximately 70°F(21°C). Connect an ohmmeter to pins 3 and 4 of the J3 connector. At 60°F(16°C) the reading should be 15.3k ± 2k OHMS, at 70°F(21°C) the reading should be 11.8k ± 2k OHMS, and at 80°F(27°C) the reading should be 9.3k ± 2k OHMS. If the probe is within these parameters, reconnect the J3 plug to the control board.
	3. Control Board	Set the temperature to 200°F (95°C). Let tank temperature stabilize. If temperature in tank is above temperature setting by more than 7°F, replace the control board. (See page 22)
Brewer is making unusual noises	1. Plumbing lines	Plumbing lines should not rest on the counter top.
	2. Water supply	The brewer must be connected to a cold water supply.
	3. Lime build up	Remove the tank lid and clean inside of tank with a deliming agent, if necessary.

## TROUBLESHOOTING (cont.)

### BREWING CIRCUIT

<b>PROBLEM</b>	<b>PROBABLE CAUSE</b>	<b>REMEDY</b>
Brew cycle will not start	1. Display flashing	Brewer has shut down due to malfunction (See Diagnostic Chart in manual, Page 20, or under top lid of brewer).
	2. No water	Water lines and valves to the brewer must be open.
	3. No power or incorrect voltage to the brewer	Check for voltage across the black and white terminals at the terminal block(s).
	4. ON/OFF switch not in the "ON" position	The indicator lamp must be lit
	5. Low water temperature (Brew lockout is enabled)	Allow brewer to heat until ready lamp is lit, or disable the brew lockout feature. (See page 7)
	6. Water not touching refill probe inside tank	Press ON/OFF switch (indicator must be lit). Brewer will refill until water touches probe inside tank. Water must be in contact with refill probe before brew cycle will start.
	7. Switch panel	Disconnect the brewer from the power source. Disconnect the ribbon connector from the control board. Check for continuity between pins 1 & 2 (An arrow on the connector indicates pin 1). No continuity should be present. Press the BREW switch. Continuity should be present for as long as the switch is held "ON". If no continuity is present, replace the switch membrane decal. (See page 23)



## TROUBLESHOOTING (cont.)

### BREWING CIRCUIT (cont.)

#### PROBLEM

---

Brew cycle will not start (cont.)

#### PROBABLE CAUSE

---

8. Control board or dispense valve

#### REMEDY

---

If the switch panel is operating properly, proceed as follows. Attach a voltmeter to the terminals of the dispense solenoid. Connect the brewer to the power source. Turn on the brewer and press the BREW switch. Voltage should be present at the solenoid terminals. If voltage is not present, refer to the wiring diagrams and check the wiring harness. If voltage is present, check for continuity across the terminals of the solenoid coil. If continuity is not present, replace the solenoid (See page 24). If continuity is present, the valve may be stuck closed.

Consistently low beverage level in the dispenser or beverage overflows dispenser

1. Brew volume

Set up brewer according to instructions in section **Adjustments-Brew Volumes**. (See page 8) Using a stop watch or second hand, time the length of the brew cycle. Record this time inside the top lid. If service is ever needed again, use the time as reference to determine if time has changed.

2. Lime build up

Inspect the dispense valve and sprayhead for excessive lime deposits. Delime as required.

3. Dispense Valve

Remove dispense valve and clear any obstructions. Rebuild or replace valve if necessary. (See page 24)

## TROUBLESHOOTING (cont.)

### BREWING CIRCUIT (cont.)

<b>PROBLEM</b>	<b>PROBABLE CAUSE</b>	<b>REMEDY</b>
Dripping from sprayhead	1. Lime build up	Inspect the tank assembly for excessive lime deposits. Delime as required.
	2. Dispense valve	Remove the dispense valve and clear any obstructions. Rebuild or replace the valve if necessary. (See page 24)
Weak beverage	1. Sprayhead	A clean stainless steel sprayhead must be used for proper extraction.
	2. Water temperature	Place an empty brew funnel on an empty decanter/server beneath the sprayhead. Initiate brew cycle and check the water temperature immediately below the sprayhead with a thermometer. The reading must not be less than 195°F(91°C). Adjust the temperature setting to increase the water temperature. Refer to <i>Initial Set-up</i> instructions.
	3. Filter type	BUNN® paper filters must be used for proper extraction.
	4. Coffee grind	A fine or drip grind must be used for proper extraction.
	5. Funnel loading	The BUNN® paper filter must be centered in the funnel and the bed of grounds leveled by shaking gently.

## TROUBLESHOOTING (cont.)

### BREWING CIRCUIT (cont.)

<b>PROBLEM</b>	<b>PROBABLE CAUSE</b>	<b>REMEDY</b>
Dry coffee grounds remain in the funnel	1. Sprayhead	Make sure sprayhead is present and holes are clear and unobstructed. There should be separate streams of water coming out of each hole in the sprayhead.
	2. Funnel loading	The BUNN® paper filter must be centered in the funnel and the bed of grounds leveled by shaking gently.
Low beverage serving temperature	1. Warmer	Disconnect the brewer from the power source. Remove the warmer plate and turn upside down to expose the warmer terminals. Remove the two wires. Check for continuity across the two warmer terminals. If continuity is not present, replace the warmer element (See page 29). If continuity is present, reconnect the wires to the warmer element. Check for voltage at the warmer terminals. Turn the warmer switch "ON". The indicator light will come on. Voltage should be present at the terminals. If not, disconnect power supply and check wiring and switch.

## DIAGNOSTICS

Intermittent flashing of the bank of temperature indicators indicates that a fault exists. Count the number of flashes between pauses and use this chart as a guide to investigating the fault.

FLASHES	CAUSE	THINGS TO CHECK
1	Dry Plug - In Fault - Sheath of temperature probe dry for 10 minutes after power-up	Water Pressure (is water shut off?) Temperature probe wiring Fill valve wiring, function, & strainer Green wire between tank and circuit board
2	Low Tank Level Fault - Level probe dry for 7 minutes after fill valve is energized	Water pressure (is water shut off?) Level probe wiring Temperature probe wiring Fill valve wiring, function, & strainer
3	Low Water Temperature Fault - Sensor in tank is calling for heat for 30 minutes or more	Tank heater wiring & function Temperature probe wiring
4	Tank Sensor Disagreement - Level probe detects water, but dry plug-in probe dry	Temperature probe wiring Level probe wiring Green wire between tank and circuit board
5	Temp Sensor Out-of-Range - High	Sensor not connected to circuit board
6	Temp Sensor Out-of-Range - Low	Sensor wires shorted together or to chassis

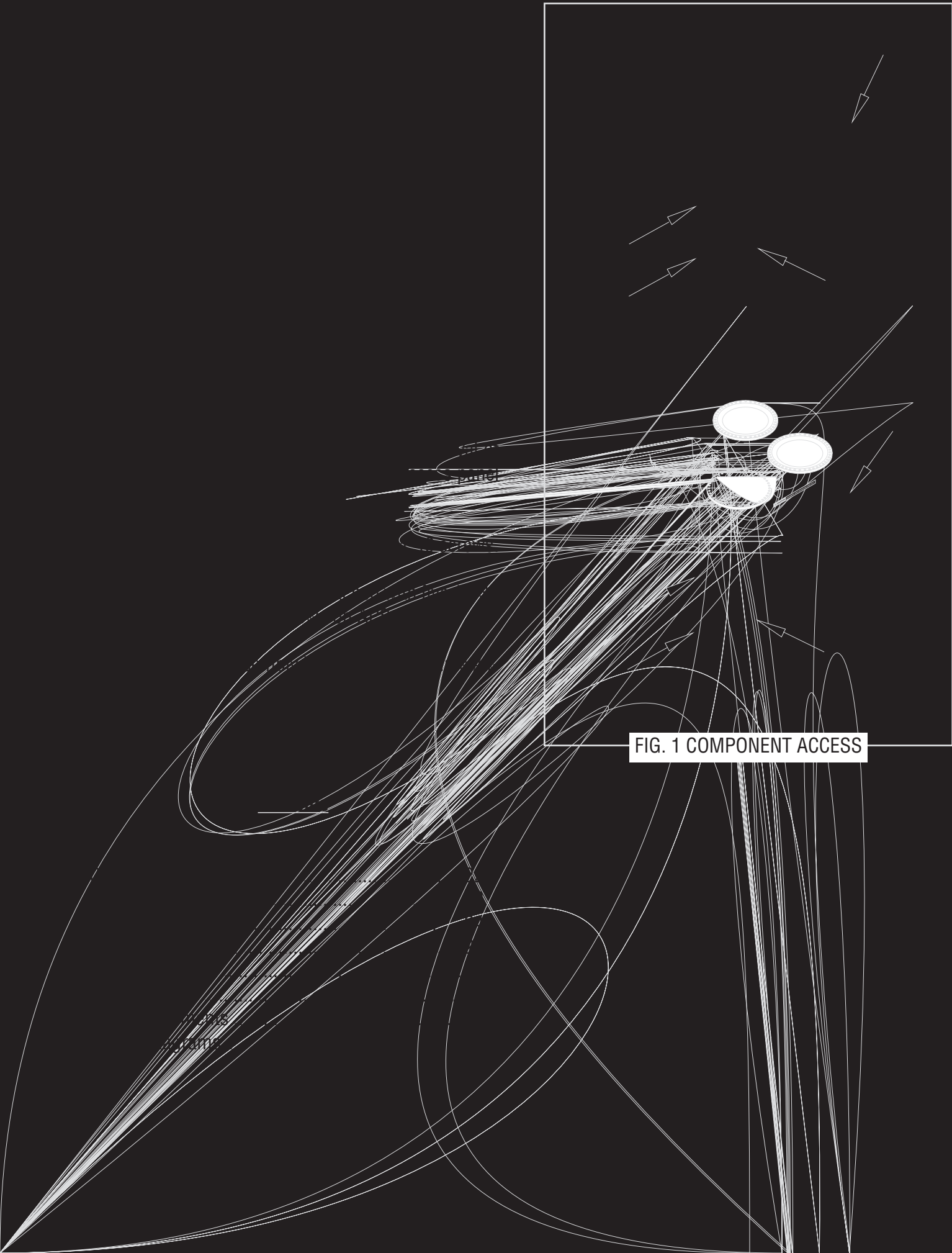
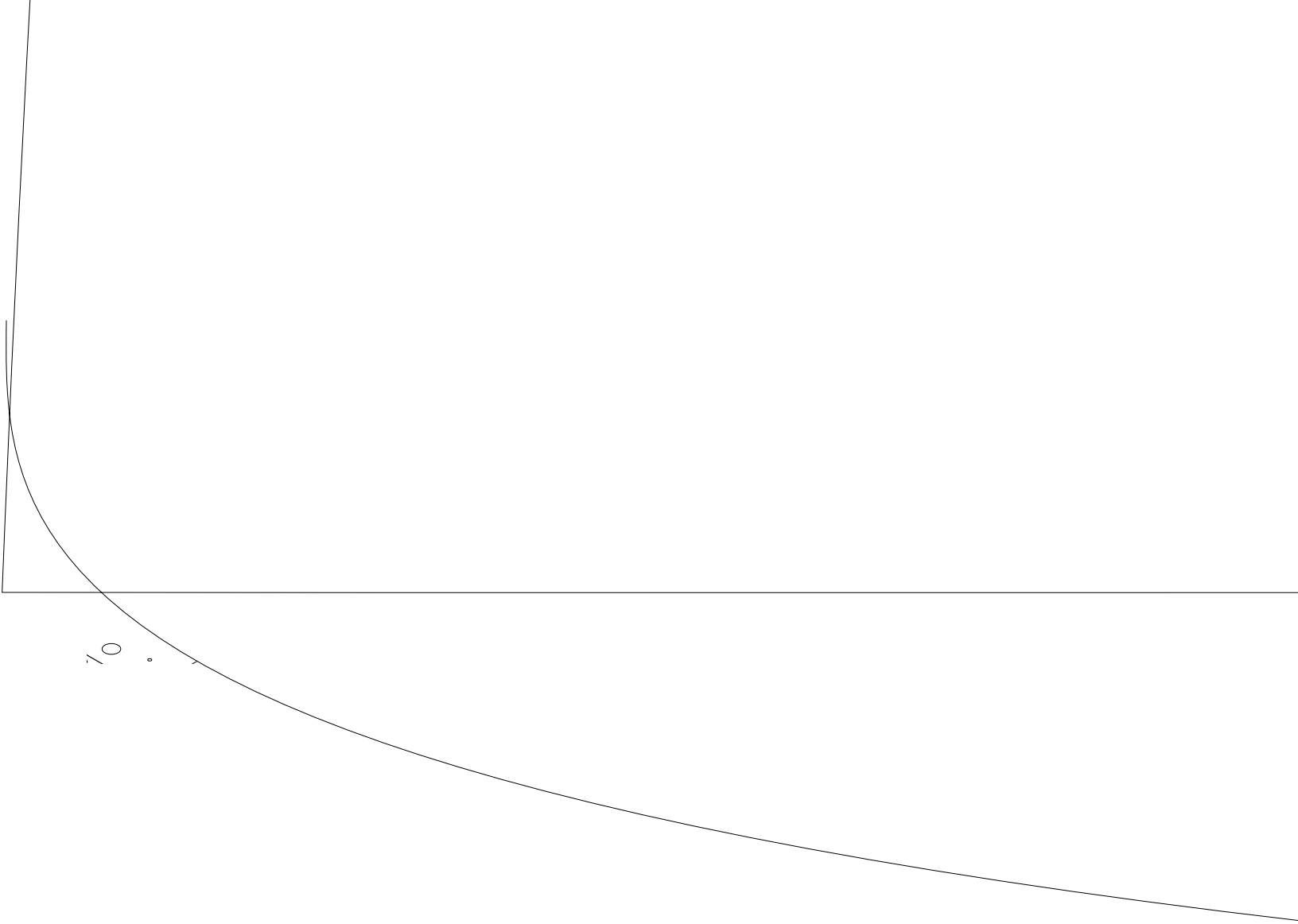

FIG. 1 COMPONENT ACCESS



## SERVICE (cont.)

### SWITCH PANEL

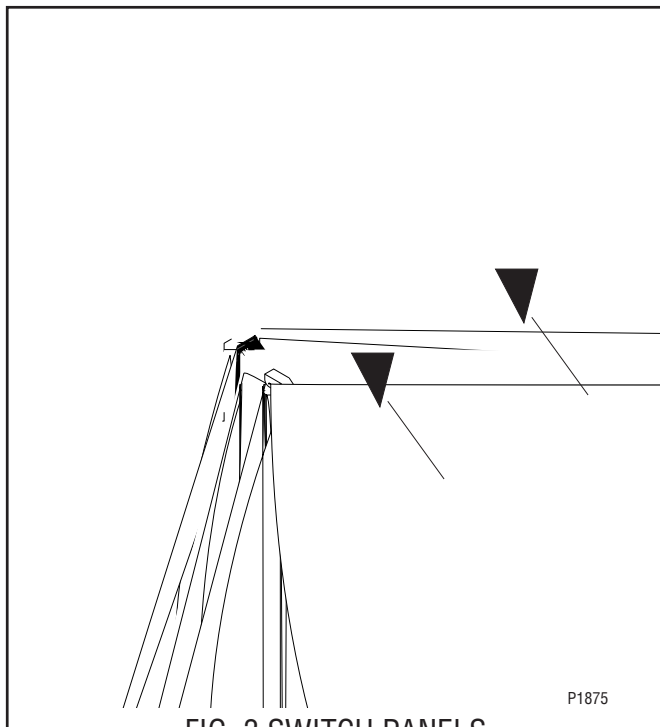

FIG. 3 SWITCH PANELS

#### Location:

The Switch Panels are located on the front of the hood.

#### Test Procedures:

The test procedures for the switch panels and the control boards will vary depending upon the problems experienced by the brewer. Refer to the troubleshooting guide beginning on page 10. The troubleshooting guide is divided into three sections, Refill Circuit, Heating Circuit and Brewing Circuit.

#### Removal and Replacement:

1. Disconnect the 11-pin connector to the switch panel from the control board.
2. Remove the four #6 screws, nylon washers and the two #4 screws securing the control board to the end cap assembly and set aside.
3. Gently pry the switch panel from the end cap assembly.
4. Remove any adhesive that remains on the end cap.
5. Remove the adhesive backing from the new switch panel. Insert the ribbon connector through the slot in the end cap and apply the switch panel to the end cap.
6. Install the control board to the back side of the end cap using the four #6 screws, nylon washers and the two #4 screws to the end cap assembly.  
**NOTE:** The four nylon washers **must** be installed under the heads of the four #6 screws to prevent possible shorting of the control board circuits.
7. Reconnect the 11-pin connector from the switch panel to the control board making sure every pin on the control board is inserted into the ribbon cable plug.

## SERVICE (cont.)

### DISPENSE VALVE

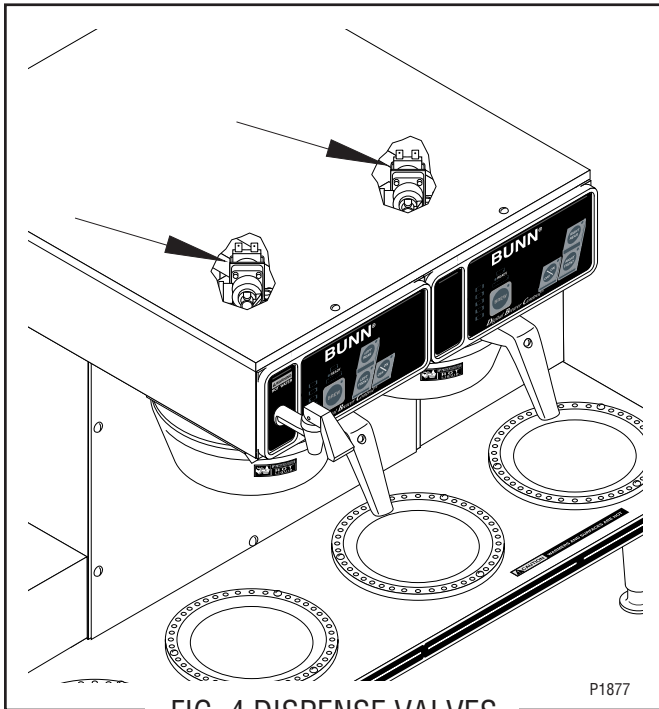

#### Location:

The dispense valves are located inside the top cover, attached to the sprayhead panels.

#### Test Procedures:

1. Disconnect the brewer from the power source.
2. Check the water level in the tank to confirm that it is within 1/2" from the top of the tank.
3. Connect the brewer to the power source. If the brewer has been set for brewer temperature lock-out, this feature must be disabled. (See Page 7 for procedure.)
4. Check the dispense valve for coil action. Place the ON/OFF switch in the "ON" position, press and release the BREW switch. Listen carefully in the vicinity of the dispense valve for a "clicking" sound as the coil magnet attracts and repels the plunger.
5. Disconnect the brewer from the power source.

If the sound is heard as described, there may be a blockage in the dispense valve or the water line to the sprayhead. Remove the dispense valve and inspect for wear, and remove waterborne particles.

If the sound is not heard as described, proceed to #6.

6. Connect the voltmeter lead ends to the dispense valve coil terminals. Connect the brewer to the power source. Brewer temperature lockout must be disabled. Place "ON/OFF" Switch in the "ON" position. Press and release the brew switch. The indication must be 120 volts ac for two-wire 120 volt models and three-wire 120/208 or 120/240 volt models.
7. Disconnect the brewer from the power source.

If voltage is present as described, but no coil action is observed, nor "clicking" heard, dispense valve is defective. Replace valve and test again to verify repair. If voltage is not present as described, refer to *Wiring Diagrams* and check the brewer wiring harness. Also check the control board for proper operation. (See Page 22.)

#### Removal and Replacement:

1. Disconnect wires from the dispense valve.
2. Drain enough water from the tank so the dispense valve is above the water line.
3. Remove water lines from the dispense valve.
4. Remove the two #8-32 nuts securing the dispense valve to the sprayhead panel.
5. Install a new dispense valve using the two #8-32 nuts.
6. Reconnect water lines to the dispense valve and secure in place with clamps.
7. Refer to FIG. 5 when reconnecting wires.

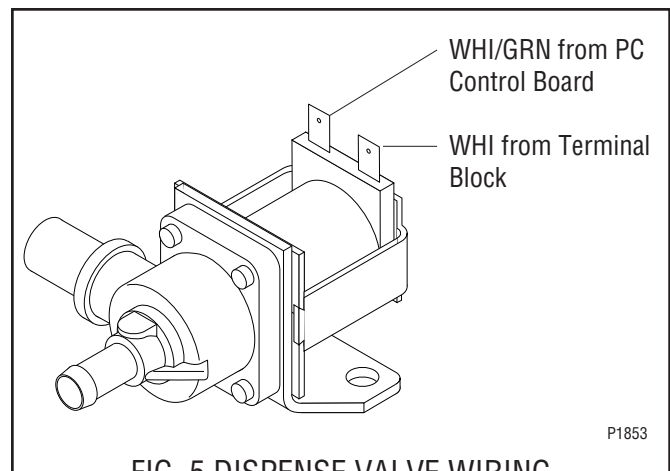



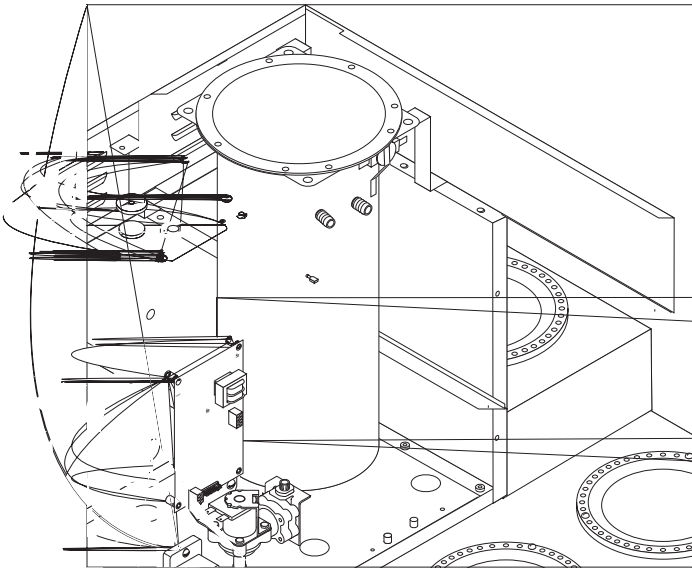

## SERVICE (cont.)

### TANK HEATERS

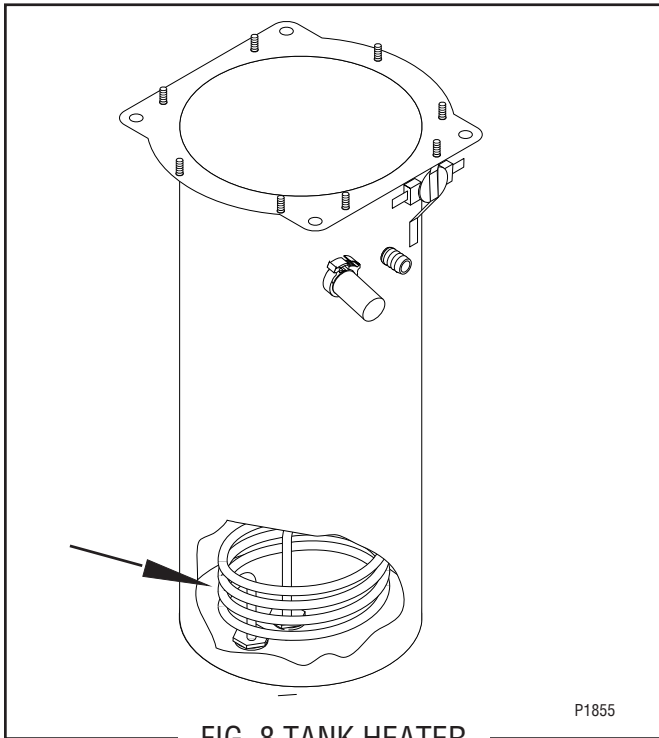

FIG. 8 TANK HEATER

#### Location:

The tank heaters are located inside the tanks and secured to the tank bottoms.

#### Test Procedures:

1. Disconnect the brewer from the power supply.
2. With a voltmeter, check the voltage across the red wire from the terminal block and the black wire from the control board. Connect the brewer to the power source. The indication must be 240 volts ac.
3. Disconnect the brewer from the power source.

If voltage is present as described, proceed to #4

If voltage is not present as described, refer to the *Wiring Diagrams* and check wiring harness.

4. Disconnect the black wire and the red wire from the tank heater terminals.
5. Check for continuity across the tank heater terminals.

If continuity is present as described, reconnect the wires, the tank heater is operating properly. If continuity is not present as described, replace the tank heater.

**NOTE-** If the tank heater remains unable to heat, remove and inspect heater for cracks in the sheath.

#### Removal and Replacement:

1. Remove the top cover or top warmer housing and front access panel as previously described.
2. Disconnect the vent hose from the top of the tank by pulling the elbow fitting from the grommet in the top of the tank lid.
3. Drain water from the tank.
4. Disconnect the water supply tube to the dispense valve from the side of the tank.
5. Disconnect the water supply tube to the solenoid valve from the bottom of the tank.
6. If removing the left tank, on brewers with faucet, disconnect the outlet water line to the faucet from the side of the tank.
7. Disconnect the temperature probe and clip (black lead) from the top of the tank by pulling the probe from the grommet in the top of the tank lid.
8. Disconnect the pink wire from the level probe.
9. Disconnect the green wire from the top of the tank.
10. Disconnect the limit thermostat from the side of the tank.
11. Disconnect the two white wires from the tank warmer blanket.
12. Disconnect the black wire and red wire from the tank heater terminals.
13. Remove the four #8-32 nuts securing the tank to the mounting brackets and remove the tank assembly.
14. Remove the eight #8-32 nuts securing the tank lid to the tank.
15. Remove the two hex nuts securing the tank heater to the bottom of the tank. Remove tank heater with gaskets and discard.
16. Install new tank heater with gaskets to the bottom of the tank and secure with two hex nuts.

## SERVICE (cont.)

### TANK HEATERS (Cont.)

17. Install tank assembly onto mounting brackets and secure in place with four #8-32 nuts.
18. Install tank lid and secure in place with eight #8-32 nuts.
19. Connect the two white wires of the tank warmer blanket.
20. Connect the limit thermostat to the front of the tank assembly.
21. Connect the green wire to the tank mounting bracket using #8-32 nut.
22. Connect the pink wire to the level probe.
23. Insert the temperature probe through the grommet in the tank lid and attach the black lead from the clip to the sheath.
24. Install the elbow fitting of the vent hose into the grommet in the tank lid.
25. If installing left tank, on brewers with faucet, connect the outlet water line of the faucet to the side of the tank and secure with clamp.
26. Connect the water supply tube from the solenoid to the bottom of the tank and secure with clamp.
27. Connect the water supply tube from the dispense valve to the side of the tank and secure with clamp.
28. Refer to FIG. 9 when reconnecting the tank heater wires.
29. Install access panels and covers and refer to *Initial Set-up* for refill and operation.

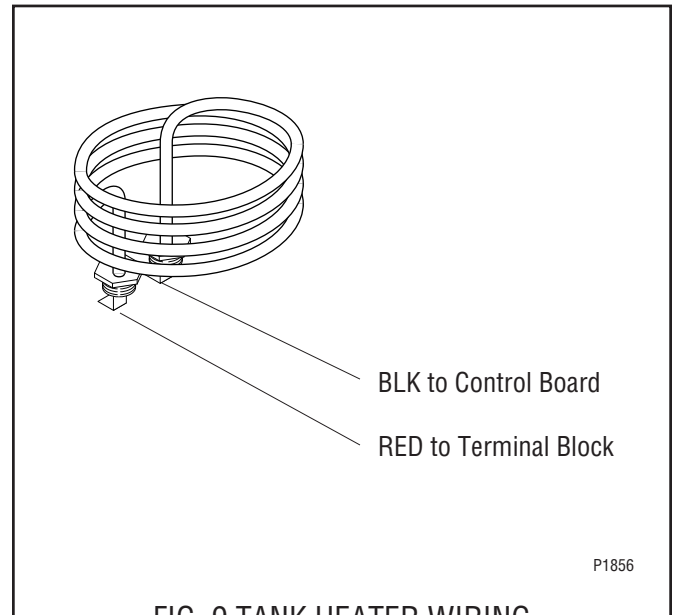
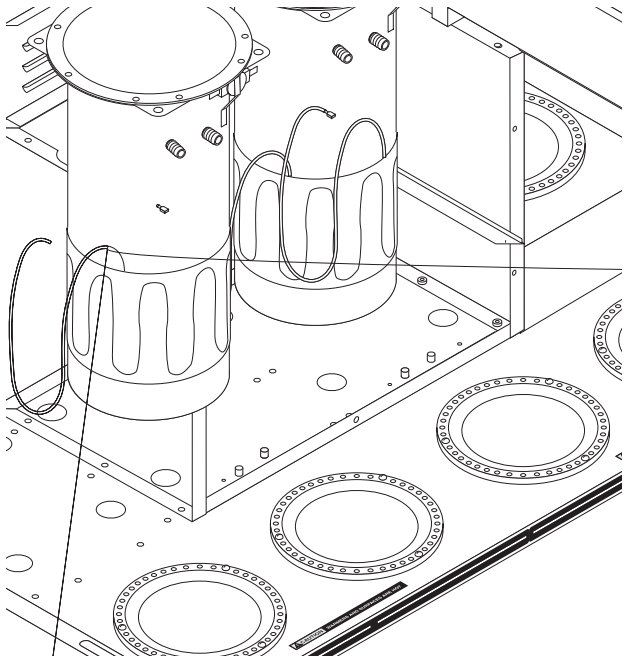

FIG. 9 TANK HEATER WIRING



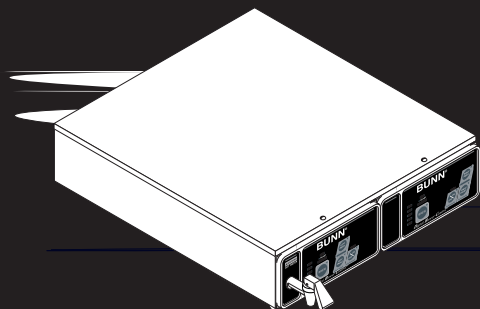

FIG. 12 WARMER ELEMENTS

Location:

The warmer elements are located on the bottom of the warmer plates.

Test Procedure:

1. Disconnect the power to the warmer.
2. Use the voltage tester to check for power on other burner wires.
3. With a multimeter, check the continuity of the wires to the "common" terminal.

**SCHEMATIC WIRING DIAGRAM CDBC TWIN 0/6 (LEFT)**

**SCHEMATIC WIRING DIAGRAM CDBC TWIN 0/6 (RIGHT)**

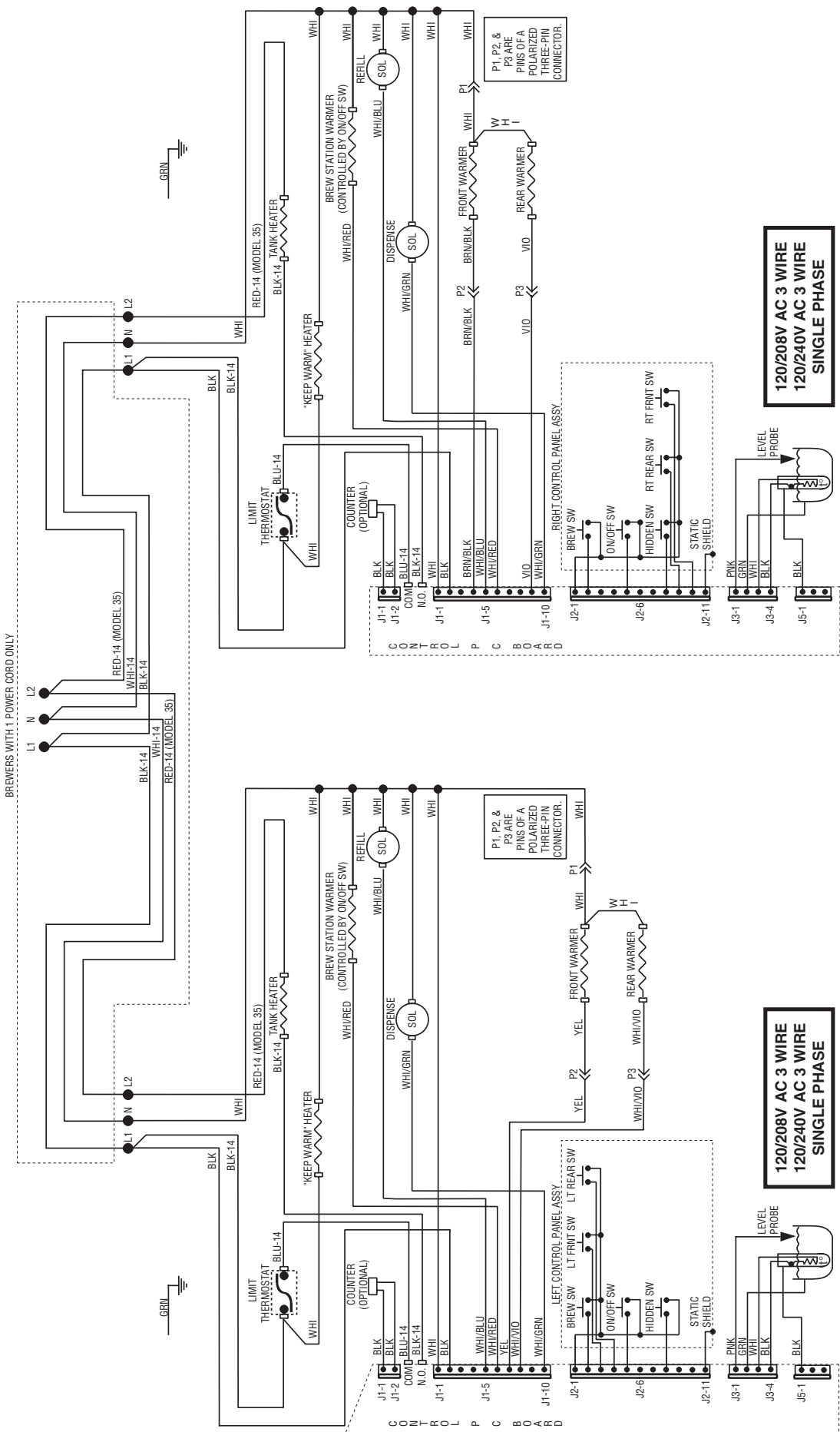

**SCHEMATIC WIRING DIAGRAM CDBC TWIN 2/2 (LEFT)**

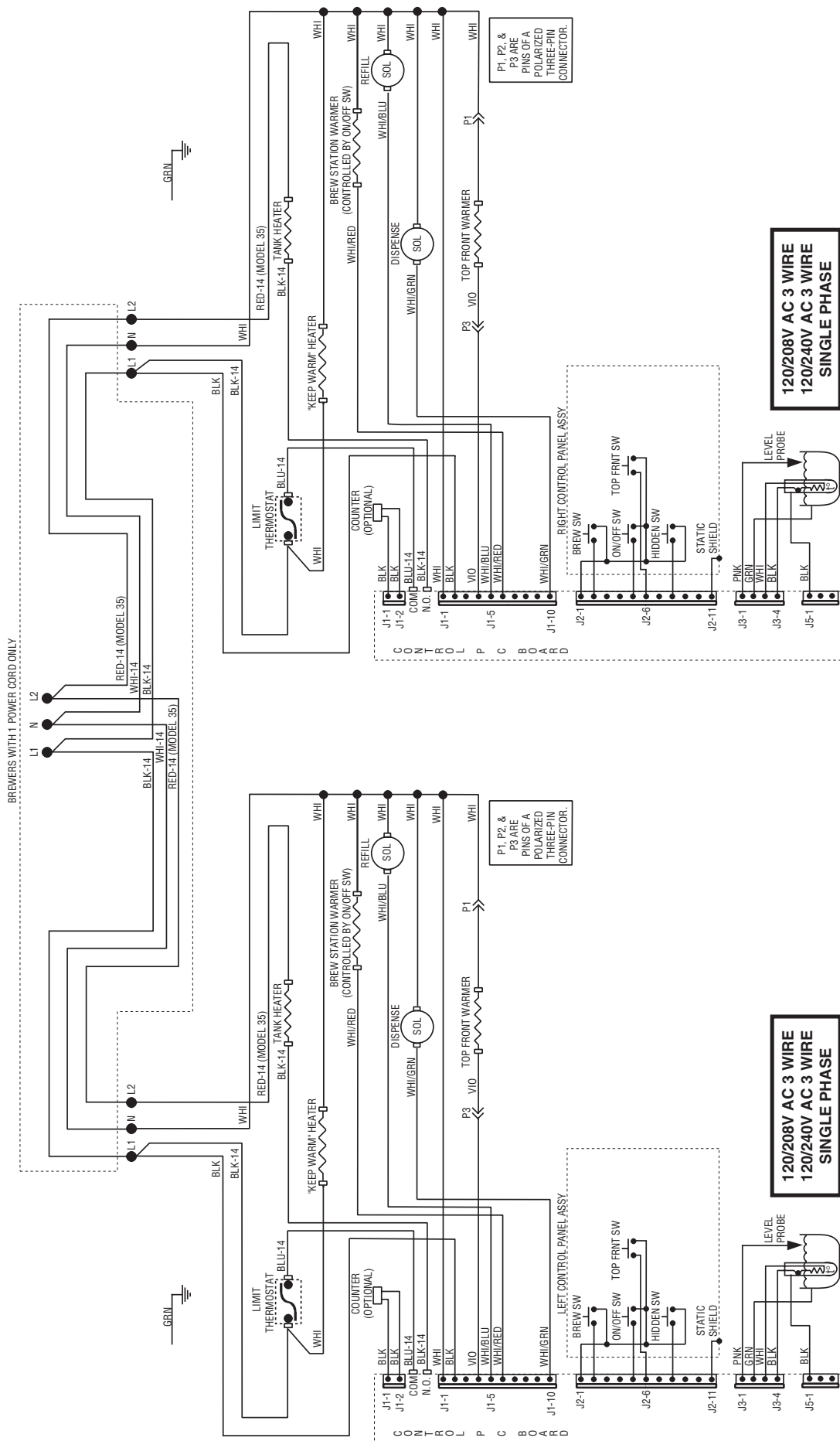

**SCHEMATIC WIRING DIAGRAM CDBC TWIN 2/2 (RIGHT)**

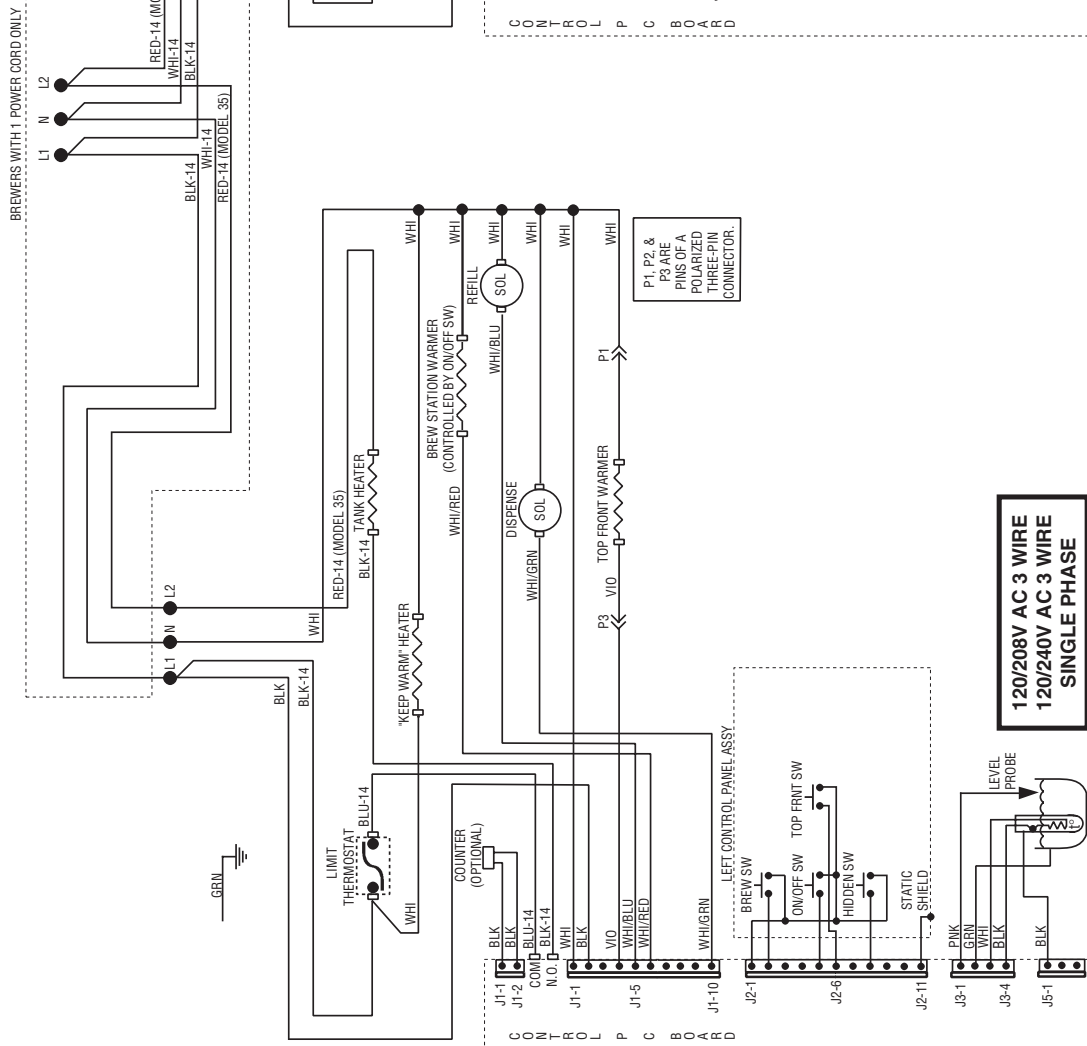

SCHEMATIC WIRING DIAGRAM CDBC TWIN APS (LEFT)

SCHEMATIC WIRING DIAGRAM CDBC TWIN APS (RIGHT)

