

Tiger Super Automatic Espresso Machine

Features



Model Tiger M Series

Dimensions: 23.8"H x 15.8"W x 17.1"D
(60.5 cm H x 40.1 cm W x 43.4 cm D)

Tiger M Series

- Up to 180 drinks per hour* from less than 16" of counter space.
- Intelligent modular brewing chamber adjusts espresso.
- Simulates Barista tamping and polishing motion to provide uniform extraction.
- Two-grinders for regular and decaf or other specialty beans.
- Pod brewing option standard on all models.
- Intuitive operational design. Easy to use control pad guides user through steps for making drinks.
- Easy daily cleaning.
- Innovative milk delivery system does not inject steam or water to dilute the foam so customers enjoy a full, rich flavor experience.
- Internal milk storage. Self-contained refrigeration system holds 1 gallon (4 litres) of your choice of milk.

*Results may vary based upon drink selection.

For current specification sheets and other information, go to www.bunn.com.

Related Products

Espresso Water Quality System

EQHP-ESP

Product No. :39000.0008

Replacement Cartridge

EQHP-ESPCRTG

Product No.: 39000.1008



Urnex® Cafiza™ Cleaning Tablets

Product No.: 36000.1189 (100 count)

Product No.: 36000.1188 (12/case)

Urnex® Rinza™

Milk Frother Cleaner

Product No.: 39265.0000 (each)

Product No.: 39265.0001 (6/case)

Model

Tiger M-2

Agency Listing



Dimensions & Specifications



Model	Product #	Volts	Amps	Tank Heater Watts	Total Watts	Capacity	Cubic ft ³ /m ³	Weight lbs/kg	Cord Attached
Tiger M-2	35800.6003	208	11.5	2000	2400	180 cups/hr*	3.7 / .105	88 / 40	Yes/
		240	12.9	2700	3100	No Plug			

*Brewing capacity varies due to type of beverage.

Model includes: Machine, water filtration system, installation and 2-year preventative maintenance.

Electrical: 120V Model requires 2-wire grounded service rated 120V, single phase, 50/60 Hz
 208 or 240V Model requires 2-wire grounded service rated 208V or 240V, single phase, 50/60 Hz

Plumbing: 20-100 psi (138 - 690 kPa). Machine supplied with 3/8" (0.95 cm) male fitting.

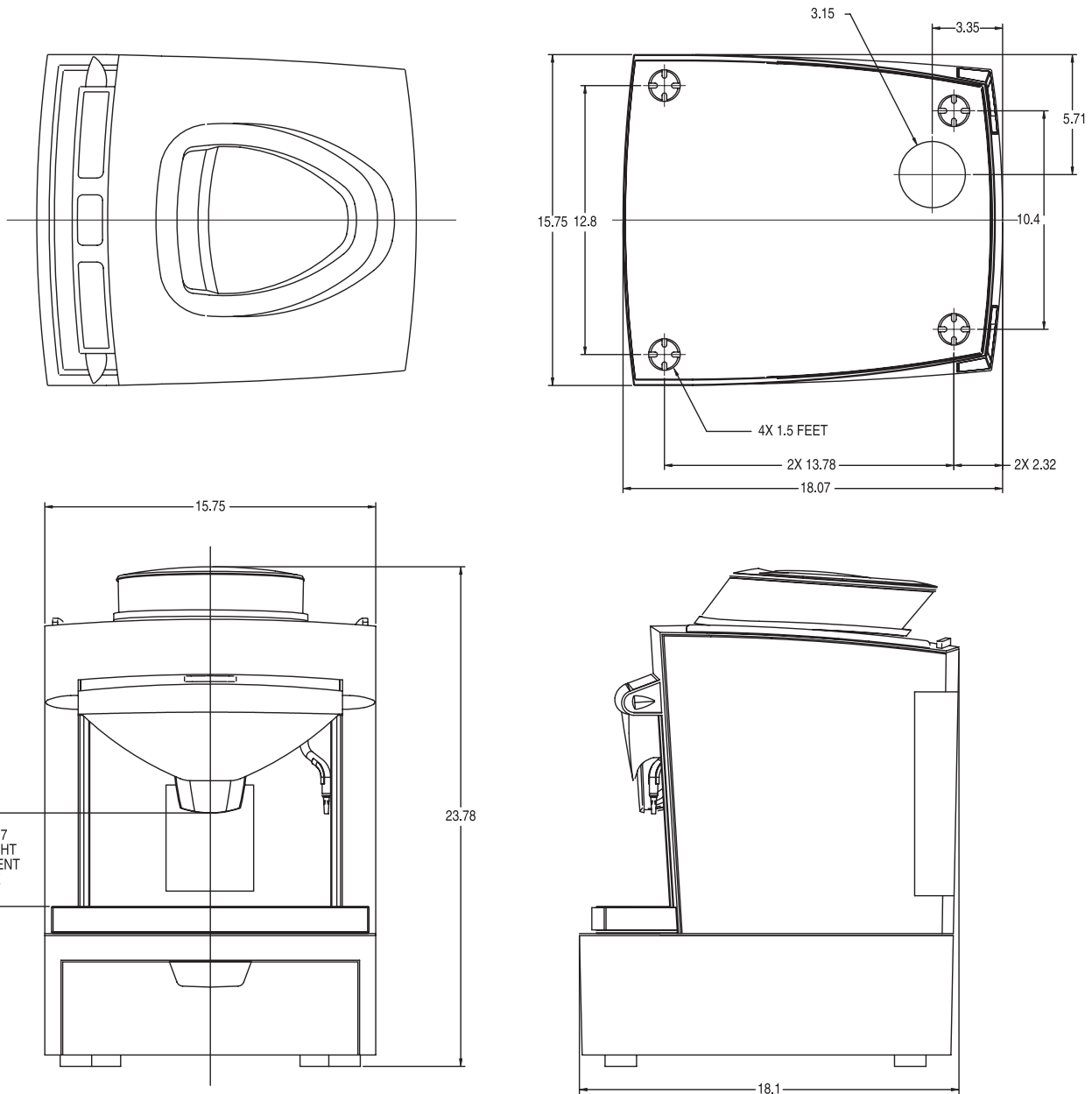

Bunn-O-Matic Corporation of Canada - 280 Industrial Pkwy. S. Aurora, Ontario L4G 3T9 • 905-841-2866 • Fax 905-841-2775 • www.bunn.com

BUNN® practices continuous product research and improvement. We reserve the right to change specifications and product design without notice. Such revisions do not entitle the buyer to corresponding changes, improvements, additions or replacements for previously purchased equipment.

All dimensions shown in inches. Bunn Corporation owns all copyrights relating to materials in this publication. Please contact Bunn Corporation to request permission to reproduce any portion of this publication.