

BUNN®

CRT5 *CRTF5*

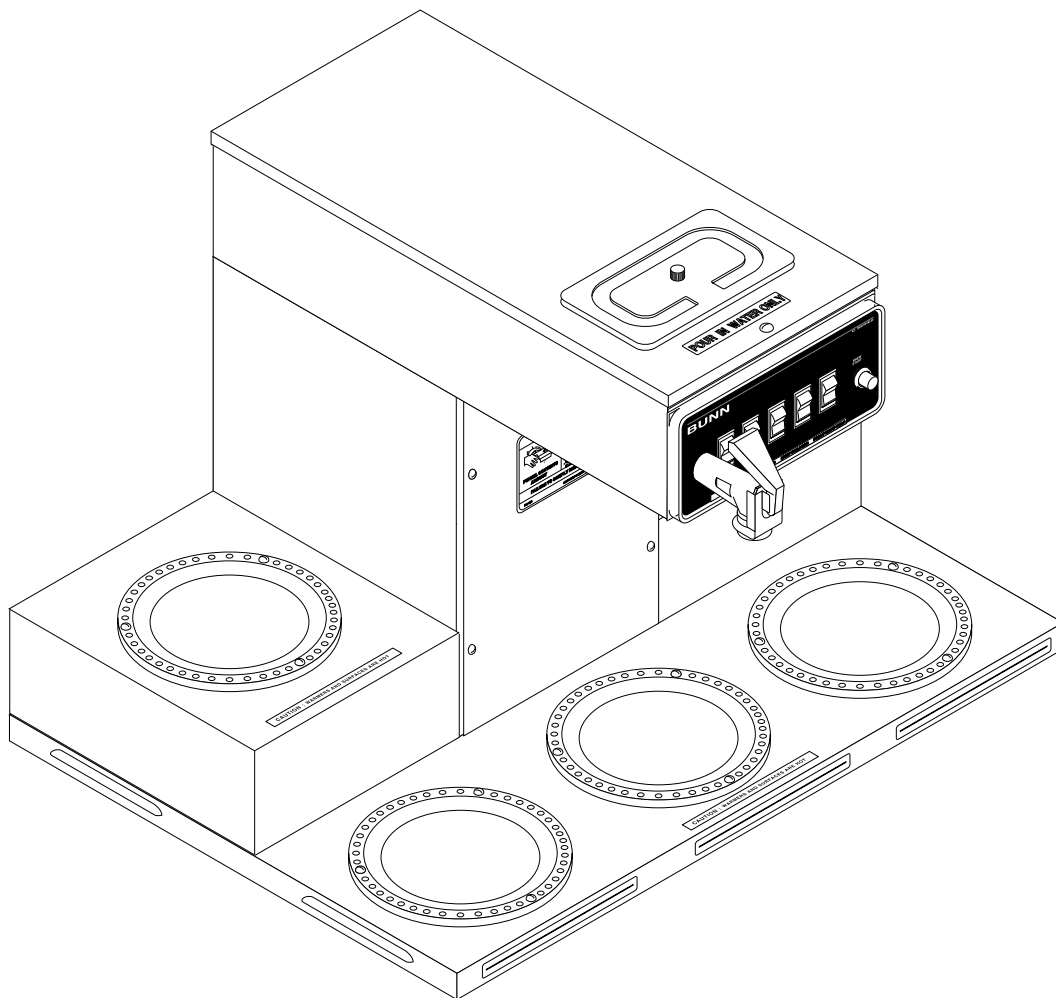

OPERATING & SERVICE MANUAL

BUNN-O-MATIC CORPORATION

POST OFFICE BOX 3227

SPRINGFIELD, ILLINOIS 62708-3227

PHONE: (217) 529-6601 FAX: (217) 529-6644

INTRODUCTION

This equipment will automatically brew a half-gallon batch of coffee into an awaiting dispenser. The brewer may include a hot water faucet for allied beverage use. It is only for indoor use on a sturdy counter or shelf.

WARRANTY

Bunn-O-Matic Corp. ("Bunn") warrants the equipment manufactured by it to be commercially free from defects in material and workmanship existing at the time of manufacture and appearing within one year from the date of installation. In addition:

1.) Bunn warrants electronic circuit and/or control boards to be commercially free from defects in material and workmanship for two years from the date of installation.

2.) Bunn warrants the compressor on refrigeration equipment to be commercially free from defects in material and workmanship for two years from the date of installation.

3.) Bunn warrants that the grinding burrs on coffee grinding equipment will grind coffee to meet original factory screen sieve analysis for three years from date of installation or for 30,000 pounds of coffee, whichever comes first.

This warranty does not apply to any equipment, component or part that was not manufactured by Bunn or that, in Bunn's judgement, has been affected by misuse, neglect, alteration, improper installation or operation, improper maintenance or repair, damage or casualty.

THE FOREGOING WARRANTY IS EXCLUSIVE AND IS IN LIEU OF ANY OTHER WARRANTY, WRITTEN OR ORAL, EXPRESS OR IMPLIED, INCLUDING, BUT NOT LIMITED TO, ANY IMPLIED WARRANTY OF EITHER MERCHANTABILITY OR FITNESS FOR A PARTICULAR PURPOSE. The agents, dealers or employees of Bunn are not authorized to make modifications to this warranty or to make additional warranties that are binding on Bunn. Accordingly, statements by such individuals, whether oral or written, do not constitute warranties and should not be relied upon.

The Buyer shall give Bunn prompt notice of any claim to be made under this warranty by telephone at (217) 529-6601 or by writing to Post Office Box 3227, Springfield, Illinois, 62708-3227. If requested by Bunn, the Buyer shall ship the defective equipment prepaid to an authorized Bunn service location. If Bunn determines, in its sole discretion, that the equipment does not conform to the warranty, Bunn shall repair the equipment with no charge for parts during the warranty period and no charge for labor by a Bunn Authorized Service Representative during the warranty period. If Bunn determines that repair is not feasible, Bunn shall, at its sole option, replace the equipment or refund the purchase price for the equipment.

THE BUYER'S REMEDY AGAINST BUNN FOR THE BREACH OF ANY OBLIGATION ARISING OUT OF THE SALE OF THIS EQUIPMENT, WHETHER DERIVED FROM WARRANTY OR OTHERWISE, SHALL BE LIMITED, AS SPECIFIED HEREIN, TO REPAIR OR, AT BUNN'S SOLE OPTION, REPLACEMENT OR REFUND.

In no event shall Bunn be liable for any other damage or loss, including, but not limited to, lost profits, lost sales, loss of use of equipment, claims of Buyer's customers, cost of capital, cost of down time, cost of substitute equipment, facilities or services, or any other special, incidental or consequential damages.

USER NOTICES

Carefully read and follow all notices in this manual and on the equipment. All labels on the equipment should be kept in good condition. Replace any unreadable or damaged labels.

⚠ WARNING
<ul style="list-style-type: none">◆ Fill water tank before turning -on thermostat or connecting appliance to power source.◆ Use only on a properly protected circuit capable of the rated load.◆ Electrically ground the chassis.◆ Follow national/local electrical codes.◆ Do not use near combustibles.
FAILURE TO COMPLY RISKS EQUIPMENT DAMAGE, FIRE, OR SHOCK HAZARD
READ THE ENTIRE OPERATING MANUAL BEFORE BUYING OR USING THIS PRODUCT
THIS APPLIANCE IS HEATED WHENEVER CONNECTED TO A POWER SOURCE
<small>00831.0000F 3/98 © 1988 BUNN-O-MATIC CORPORATION</small>

00831.0000

This equipment is to be installed to comply with the Basic Plumbing Code of the Building Officials and Code Administrators International, Inc. (BOCA) and the Food Service Sanitation Manual of the Food and Drug Administration (FDA).

00656.0000

⚠ WARNING	
	DISCARD DECANTER IF: <ul style="list-style-type: none">• CRACKED• SCRATCHED• BOILED DRY• HEATED WHEN EMPTY• USED ON HIGH FLAME OR EXPOSED ELECTRIC ELEMENTS
FUNNEL CONTENTS ARE HOT	
READ THE ENTIRE OPERATING MANUAL BEFORE USING THIS PRODUCT FAILURE TO COMPLY RISKS INJURY	
<small>PN: 00658.0000F 6/98 © 1985 BUNN-O-MATIC CORPORATION</small>	

00658.0000

12364.0000

⚠ CAUTION WARMERS AND SURFACES ARE HOT

00833.0000

POUR IN WATER ONLY

ELECTRICAL REQUIREMENTS

CAUTION - The brewer must be disconnected from the power source until specified in *Initial Set-Up*.

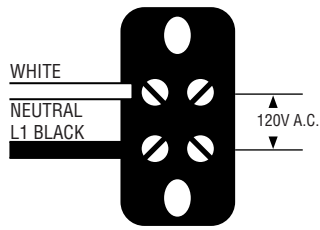

Model 20 requires 2-wire, grounded service rated 120 volts ac, 20 amp, single phase, 60 Hz. Proceed as follows:

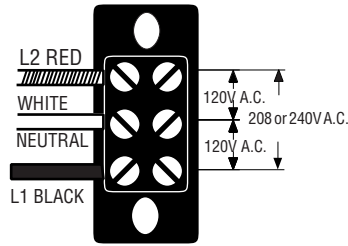

Model 35 requires 3-wire, grounded service rated 120/208 or 120/240 volts ac, 20 amp, single phase, 60 Hz. Proceed as follows:

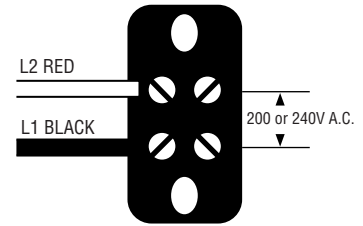

"A" & "B" models require 2-wire, grounded service rated 200 volts ac or 240 volts ac, 20 amp, single phase, 50 Hz. Proceed as follows:

Electrical Hook-Up

CAUTION – Improper electrical installation will damage electronic components.

1. An electrician must provide electrical service as specified.
2. Using a voltmeter, check the voltage and color coding of each conductor at the electrical source.
3. Place the heater switch at the rear of the brewer in the "OFF" lower position.
4. Remove the front panel beneath the sprayhead.
5. Feed the cord through the strain relief and connect it to the terminal block.
6. Connect the brewer to the power source and verify the voltage at the terminal block before proceeding. Replace the front panel.
7. If plumbing is to be hooked-up later be sure the brewer is disconnected from the power source. If plumbing has been hooked-up, the brewer is ready for Initial Set-Up.

PLUMBING REQUIREMENTS

These brewers must be connected to a cold water system with operating pressure between 20 and 90 psi (138 620 kPa) from a ½" or larger supply line. A shut-off valve should be installed in the line before the brewer. Install a regulator in the line when pressure is greater than 90 psi (620 kPa) to reduce it to 50 psi (345 kPa). The water inlet fitting is ¼" flare.

NOTE - Bunn-O-Matic recommends ¼" copper tubing for installations of less than 25 feet and ⅜" for more than 25 feet from the ½" water supply line. A tight coil of copper tubing in the water line will facilitate moving the brewer to clean the countertop. Bunn-O-Matic does not recommend the use of a saddle valve to install the brewer. The size and shape of the hole made in the supply line by this type of device may restrict water flow.

This equipment must be installed to comply with the Basic Plumbing Code of the Building Officials and Code Administrators International, Inc. (BOCA) and the Food Service Sanitation Manual of the Food and Drug Administration (FDA).

PLUMBING REQUIREMENTS (cont.)

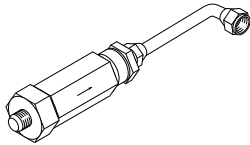

P2188

MODELS W/OUT FAUCET

Models CRT5, CRT5A & CRT5B

1. Remove the shipping cap from the bulkhead fitting on the rear of the brewer.
2. Attach the flare fitting from the short piece of tubing on the flow control (supplied) to the water inlet fitting at the rear of the brewer.
3. Flush the water line and securely attach it to the flare fitting on the strainer/flow control.
4. Turn on the water supply.

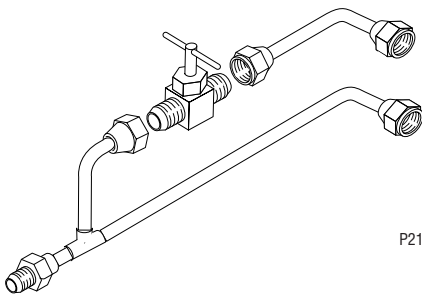

P2187

MODELS W/FAUCET & INTERNAL FLOW CONTROL

Models CRTF5 & CRTF5B

1. Remove shipping caps from the bulkhead fittings on the rear of the brewer.
2. Attach the female flare fitting on the tube from the needle valve to the upper fitting on the rear of the brewer and the female flare fitting on the manifold to the lower fitting on the rear of the brewer.
3. Flush the water supply line and securely attach it to the male flare fitting on the manifold.
4. Turn on the water supply.
5. Place an empty vessel beneath the faucet and lift the handle until water is dispensed.

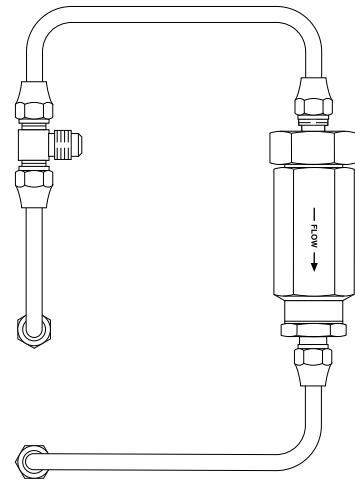

BE SURE TO INSTALL THE ABOVE ASSEMBLY AS SHOWN

MODELS W/FAUCET & EXTERNAL FLOW CONTROL

Models CRTF5, CRTF5A & CRTF5B

1. Remove the shipping caps from the bulkhead fittings on the rear of the brewer.
2. Attach the flare fitting from the short piece of tubing on the flow control (supplied) to the lower water inlet fitting at the rear of the brewer.
3. Attach the flare fitting from the short piece of tubing on the tee (supplied) to the upper water inlet fitting at the rear of the brewer.
4. Flush the water supply line and securely attach it to the flare fitting on the tee.
5. Turn on the water supply.
6. Place an empty vessel beneath the faucet and lift the handle until water is dispensed.

INITIAL SET-UP

CAUTION - The brewer must be disconnected from the power source throughout the initial set-up, except when specified in the instructions.

1. Insert an empty funnel into the funnel rails.
2. Place an empty dispenser under the funnel.
3. Place the heater switch at the rear of the brewer in the "OFF" lower position.
4. Connect the brewer to the power source, place the "ON/OFF" switch in the "ON" upper position, and momentarily press and release the start switch. Water will begin flowing into the tank. When water stops flowing into the tank, initiate a second and a third brew cycle. During the third brew cycle the tank will fill to its capacity and the excess will flow from the sprayhead, out of the funnel, and into the dispenser.
5. When the flow of water from the funnel stops, place the heater switch at the rear of the brewer in the "ON" upper position and wait approximately twenty minutes for the water in the tank to heat to the proper temperature. Some water will drip from the funnel during this time, this is due to expansion and should not occur thereafter.
6. Empty the dispenser and initiate another brew cycle. Place the "ON/OFF" switch in the "ON" upper position, and momentarily press and release the start switch.
7. Place the "ON/OFF" switch in the lower "OFF" position after water has stopped flowing from the funnel, and let the water in the tank reheat to the proper temperature.
8. Empty the dispenser and place the "ON/OFF" switch in the "ON" upper position, and momentarily press and release the start switch. Check the water volume in the dispenser after water has stopped flowing from the funnel. It should be 64 ounces.
9. If not, disconnect the brewer from the power source, remove the front panel, and adjust the brew timer as required. See *Adjusting Brew Volumes*. Replace the front panel, connect the brewer to the power source, and allow the water to reheat, start, and measure another brew cycle.
10. Repeat step 9 until 64 oz water volume is achieved.
11. The brewer is now ready for use in accordance with the coffee brewing instructions on the next page.

ADJUSTING BREW VOLUMES

CAUTION - Disconnect the power source from the brewer prior to the removal of any panel for the replacement or adjustment of any component.

NOTE: Prior to setting or modifying batch sizes, check that the brewer is connected to water supply, the tank is properly filled, and a funnel and server are in place.

1. **Modifying batch sizes.** To modify a batch volume, first check that the SET/LOCK switch is in the "SET" position on the circuit board.

To increase a batch size. Press and hold the START or BREW switch until three clicks are heard. Release the switch (Failure to release the switch within two seconds after the third click causes the volume setting to be aborted and previous volume setting will remain in memory) and press it again one or more times. Each time the switch is pressed, two seconds are added to the brew time period. Allow the brew cycle to finish in order to verify that the desired volume has been achieved.

To decrease a batch size. Press and release the START or BREW switch once for every two-second interval to be removed from the total brew time period; then immediately press and hold down the START or BREW switch until three clicks are heard. Release the switch. (Failure to release the switch within two seconds after the third click causes the volume setting to be aborted and previous volume setting will remain in memory). Allow the brew cycle to finish in order to verify that the desired volume has been achieved.

ADJUSTING BREW VOLUMES(cont)

2. **Setting batch sizes.** To set a batch volume, first check that the SET/LOCK switch is in the "SET" position on the circuit board. Press and hold the START or BREW switch until three distinct clicks are heard, and then release the switch. (Failure to release the switch within two seconds after the third click causes the volume setting to be aborted and previous volume setting will remain in memory). View the level of the liquid being dispensed. When the desired level is reached, turn the ON/OFF switch to "OFF". The brewer remembers this volume and will continue to brew batches of this size until the volume setting procedure is repeated.

NOTE: When brewing coffee, batch volumes will decrease due to absorption by the coffee grounds.

3. **Setting programming disable feature.** If it becomes necessary to prevent anyone from changing brew times once programmed, you can set the SET/LOCK switch to the "LOCK" position. This will prevent any programming to be done until switch is once again placed in the "SET" position.

OPERATING CONTROLS

ON/OFF SWITCH

Placing the "ON/OFF" switch in the "OFF" lower position stops brewing. Stopping a brew cycle after it has been started will not stop the flow of water into the funnel until the tank syphons down to its proper level. Placing the switch in the "ON" upper position supplies power to the brew station warmer and enables the brew circuit.

START SWITCH

Momentarily pressing and releasing the switch starts a brew cycle when the "ON/OFF" switch is in the "ON" upper position.

NOTE – The "ON/OFF" switch must be in the "ON" upper position to initiate and complete a brew cycle.

COFFEE BREWING

1. Insert a BUNN® filter into the funnel.
2. Pour the fresh coffee into the filter and level the bed of grounds by gently shaking.
3. Slide the funnel into the funnel rails.
4. Place an empty dispenser beneath the funnel.
5. Place the "ON/OFF" switch in the "ON" upper position. Momentarily press and release the start switch.
6. When brewing is completed, simply discard the grounds and filter.

CLEANING

1. The use of a damp cloth rinsed in any mild, non-abrasive, liquid detergent is recommended for cleaning all surfaces on Bunn-O-Matic equipment.
2. Check and clean the sprayhead. The sprayhead holes must always remain open.
3. With the sprayhead removed, insert the delimiting spring (provided) all the way into the sprayhead tube. When inserted properly, no more than two inches of spring should be visible. Saw back and forth five or six times.

NOTE – In hard water areas, this may need to be done daily. It will help prevent liming problems in the brewer and takes less than a minute.

TROUBLESHOOTING

A troubleshooting guide is provided to suggest probable causes and remedies for the most likely problems encountered. If the problem remains after exhausting the troubleshooting steps, contact the Bunn-O-Matic Technical Service Department.

- Inspection, testing, and repair of electrical equipment should be performed only by qualified service personnel.
- All electronic components have 120 volt ac and low voltage dc potential on their terminals. Shorting of terminals or the application of external voltages may result in board failure.
- Intermittent operation of electronic circuit boards is unlikely. Board failure will normally be permanent. If an intermittent condition is encountered, the cause will likely be a switch contact or a loose connection at a terminal or crimp.
- Solenoid removal requires interrupting the water supply to the valve. Damage may result if solenoids are energized for more than ten minutes without a supply of water.
- The use of two wrenches is recommended whenever plumbing fittings are tightened or loosened. This will help to avoid twists and kinks in the tubing.
- Make certain that all plumbing connections are sealed and electrical connections tight and isolated.
- This brewer is heated at all times. Keep away from combustibles.

- WARNING** –
- Exercise extreme caution when servicing electrical equipment.
 - Unplug the brewer when servicing, except when electrical tests are specified.
 - Follow recommended service procedures
 - Replace all protective shields or safety notices

PROBLEM	PROBABLE CAUSE	REMEDY
Brew cycle will not start	1. No water	Water lines and valves to the brewer must be open.
	2. No power or incorrect voltage to the brewer	(A1) Check the terminal block for 120 volts across the black and white terminals on two wire 120 volt brewers. (A2) Check the terminal block for 120 volts across the red and white terminals and the black and white terminal on three wire 120/240 volt brewers. (A3) Check the terminal block for 200 volts on "B Series" brewers or 240 volts on "A Series" brewers across the red and black terminals. (B) Check circuit breakers or fuses.

TROUBLESHOOTING (cont.)

PROBLEM

PROBABLE CAUSE

REMEDY

Brew cycle will not start (cont.)

3. ON/OFF Switch

Refer to *Service* - ON/OFF Switch for testing. See page 17

4. Start Switch

Refer to *Service* - Start Switch for testing procedures. See page 19

5. Timer

Refer to *Service* - Timer for testing procedures. See page 25 or 27

6. Solenoid Valve

Refer to *Service* - Solenoid Valve for testing procedures. See page 18

7. Water strainer/flow control
(.222 GPM)

(A) Direction of flow arrow must be pointing towards brewer.

(B) Remove the strainer/flow control and check for obstructions. Clear or replace.

Water is not hot

1. Tank Heater Switch

Refer to *Service* - Tank Heater Switch for testing procedures. See page 22

2. (A) Limit Thermostat
(B) Thermal Cut-Off (Brewers with Faucet)

CAUTION - Do not eliminate or bypass limit thermostat or thermal cut-off. Use only BOM replacement part.

Limit Thermostat #29329.1000

Thermal Cut-Off #20211.0100

Refer to *Service* - Limit Thermostat for testing procedures. See page 16. Thermal Cut-Off for testing procedures. See page 24

3. Control Thermostat

Refer to *Service* - Control Thermostat for testing procedures. See page 14

4. Tank Heater

Refer to *Service* - Tank Heater for testing procedures. See page 20

TROUBLESHOOTING (cont.)

PROBLEM

PROBABLE CAUSE

REMEDY

Inconsistent beverage level in dispenser

1. Strainer /flow control (.222 GPM)

(A) Direction of flow arrow must be pointing towards the brewer.

(B) Remove the strainer/flow control and check for obstruction. Clear or replace.

2. Syphon System

The brewer must be level or slightly lower in front to syphon properly.

3. Lime Build-up

CAUTION - Tank and tank components should be delimed regularly depending on local water conditions. Excessive mineral build-up on stainless steel surfaces can initiate corrosive reactions resulting in serious leaks.

Inspect the tank assembly for excessive lime deposits. Delime as required.

4. Water Pressure

The water pressure to the brewer must be at least 20 psi (138 kPa).

Consistently low beverage level in the dispenser

1. Timer

Timer dial must indicate at least two minutes and fifteen seconds.

2. Strainer/flow Control (.222 GPM)

(A) Direction of flow arrow must be pointing towards brewer.

(B) Remove the strainer/flow control and check for obstructions. Clear or replace.

Spitting or excessive steaming

1. Lime Build-up

CAUTION - Tank and tank components should be delimed regularly depending on local water conditions. Excessive mineral build-up on stainless steel surfaces can initiate corrosive reactions resulting in serious leaks.

Inspect tank assembly for excessive lime deposits. Delime as required.

TROUBLESHOOTING (cont.)

PROBLEM

PROBABLE CAUSE

REMEDY

Spitting or excessive steaming (cont.)

2. Control Thermostat

Refer to *Service* - Control Thermostat for testing procedures. See page 14

Dripping from sprayhead

1. Syphon System

The brewer must be level or slightly lower in front to syphon properly.

2. Lime Build-up

CAUTION - Tank and tank components should be delimed regularly depending on local water conditions. Excessive mineral build-up on stainless steel surfaces can initiate corrosive reactions resulting in serious leaks.

Inspect the tank assembly for excessive lime deposits. Delime as required.

3. Solenoid Valve

Remove the solenoid valve and clear any obstructions. Rebuild or replace the valve if necessary. See page 18

Water flows into tank continuously (ON/OFF Switch "ON")

1. Timer

Refer to *Service* - Timer for testing procedures. See page 25 or 27

Water flows into tank continuously (ON/OFF Switch "OFF")

1. Solenoid Valve

Remove the Solenoid Valve and clean any obstruction. Rebuild or replace the valve if necessary. See page 18

Beverage overflows dispenser

1. Dispenser

The dispenser must be completely empty before starting a brew cycle.

2. Timer

Refer to *Service* - Timer for testing procedures. See page 25 or 27

3. Solenoid Valve

Remove the Solenoid Valve and clean any obstruction. Rebuild or replace the valve if necessary. See page 18

TROUBLESHOOTING (cont.)

PROBLEM

PROBABLE CAUSE

REMEDY

Weak beverage

1. Filter Type

BUNN® paper filters must be used for proper extraction.

2. Coffee Grind

A fine or drip grind must be used for proper extraction.

3. Sprayhead

A six-hole stainless steel sprayhead must be used for proper extraction.

4. Funnel Loading

The BUNN® paper filter must be centered in the funnel and the bed of ground leveled by gentle shaking.

5. Water Temperature

Place an empty funnel on an empty dispenser beneath the sprayhead. Initiate a brew cycle and check the water temperature immediately below the sprayhead with a thermometer. The reading should not be less than 195°F (76°C). Adjust the control thermostat to increase the water temperature. Replace if necessary.

Dry coffee grounds remain in the funnel

1. Funnel Loading

The BUNN® paper filter must be centered in the funnel and the bed of grounds leveled by gently shaking.

Brewer is making unusual noises

1. Solenoid

The nut on the solenoid must be tight or it will vibrate during operation.

2. Plumbing Lines

Plumbing lines should not resting on the counter top.

3. Water Supply

(A) The brewer must be connected to a cold water line.

(B) Water pressure to the brewer must not exceed 90 psi (620 kPa). Install a regulator if necessary to lower the working pressure to approximately 50 psi (345 kPa).

TROUBLESHOOTING (cont.)

PROBLEM

PROBABLE CAUSE

REMEDY

Brewer is making unusual noises
(cont.)

4. Tank Heater

Remove and clean lime off the tank heater. See page 20

Low beverage serving temperature

1. Warmer

Refer to *Service - Warmer* element for testing procedures. See page 29

2. ON/OFF Switch

Refer to *Service - ON/OFF Switch* for testing procedures. See page 17

SERVICE

This section provides procedures for testing and replacing various major components used in this brewer should service become necessary. Refer to *Troubleshooting* for assistance in determining the cause of any problem.

WARNING - Inspection, testing, and repair of electrical equipment should be performed only by qualified service personnel. The brewer should be unplugged when servicing, except when electrical tests are required and the test procedure specifically states to plug-in the brewer.

COMPONENT ACCESS

WARNING - Disconnect the brewer from the power source before the removal of any panel or the replacement of any component.

All components are accessible by the removal of the top cover, front inspection panel and warmer plate(s).

The top cover is attached with one #4-40 screw.

The front inspection panel is attached with four #6-32 screws.

The warmer assembly is attached with three #4-40 screws.

Contents

Control Thermostat	14
Limit Thermostat	16
ON/OFF Switch	17
Solenoid (Inlet)	18
Start Switch (Brew)	19
Tank Heater	20
Tank Heater Switch	22
Thermal Cut-Off	24
Timer (Early Model)	25
Digital Brew Timer (Late Model)	27
Warmer Element	29
Wiring Diagrams	30,31 & 32

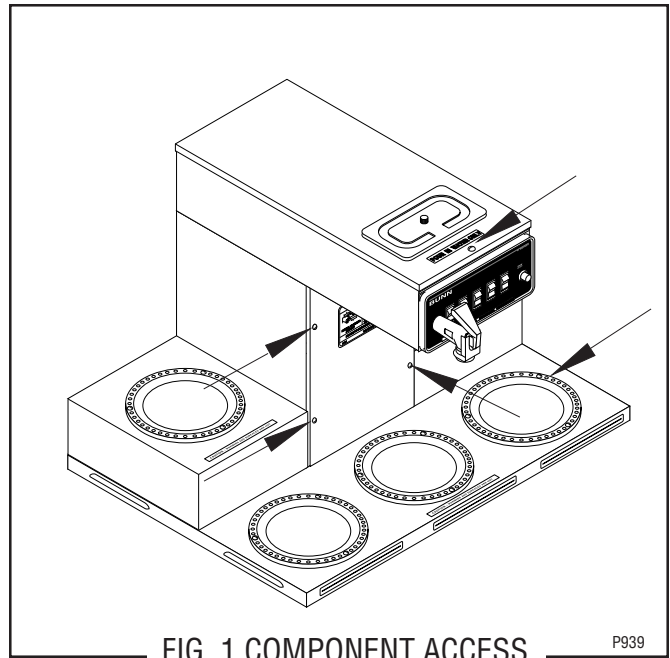

CONTROL THERMOSTAT

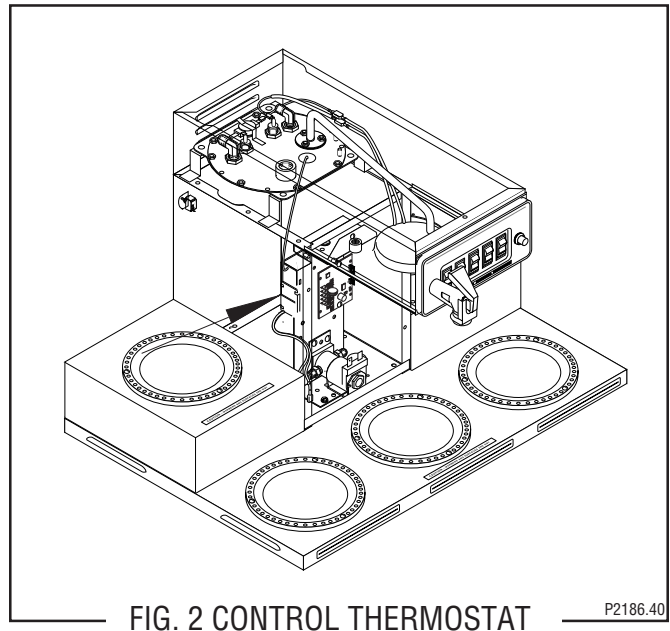

Location:

The control thermostat is located inside the trunk on the upper left side of the component bracket.

SERVICE (cont.)

CONTROL THERMOSTAT (cont.)

Test Procedures:

1. Disconnect the brewer from the power source.
2. Locate the blue wire on the control thermostat.
3. Check the voltage across the blue wire on the control thermostat and the white insert on two pole 120 volt terminal block or three pole 120/240 volt terminal blocks and the red insert on two wire 200 volt or 240 volt terminal block with a voltmeter. Connect the brewer to the power source. The indication must be:
 - a) 120 volts ac for two wire 120 volt models and three wire 120/240 volt models.
 - b) 200 to 240 volts ac for two wire 200 or 240 volt models.
4. Disconnect the brewer from the power source.

If voltage is present as described, proceed to #5. If voltage is not present as described, refer to the wiring diagrams and check the brewer wiring harness.

5. Locate the black wire on the control thermostat.
6. Gently remove the capillary bulb and grommet from the tank.
7. Check the voltage across the black wire of the control thermostat and the white insert on the two pole 120 volt or three pole 120/240 volt terminal block and the red insert on the two pole 200 volt or 240 volt terminal block with a voltmeter when the control thermostat is turned fully clockwise. Connect the brewer to the power source. The indication must be:
 - a) 120 volts ac for two wire 120 volt models and three wire 120/240 volt models.
 - b) 200 to 240 volts ac for two wire 200 volt or 240 volt models.
8. Disconnect the brewer from the power source.

If voltage is present as described, reinstall the capillary tube into the tank to the line 4.5" above the bulb, the control thermostat is operating properly. If voltage is not present as described, replace the thermostat.

Removal and Replacement:

1. Disconnect the control thermostat wires.
2. Remove the thermostat capillary bulb by firmly pulling-up on the capillary at the tank lid. This will disengage the grommet from the tank lid.
3. Remove the one #8-32 screw securing the control thermostat to the component bracket inside the trunk.
4. Slide the grommet to the line 4.5" above the bulb on the new capillary tube.
5. Insert the capillary bulb through the hole in the tank lid and press the grommet firmly and evenly so that the groove in the grommet fits into the tank lid.
6. Carefully bend the capillary tube so that the tube and bulb inside the tank are in the vertical position.

NOTE - The capillary tube must be clear of any electrical termination and not kinked.

7. Using one #8-32 screw, secure the control thermostat to the component bracket inside the trunk.
8. For first type thermostat, refer to the Fig. 3 when reconnecting thermostat wires. For second type thermostat, it does not matter which lead is connected to which terminal.
9. Adjust the control thermostat as required.

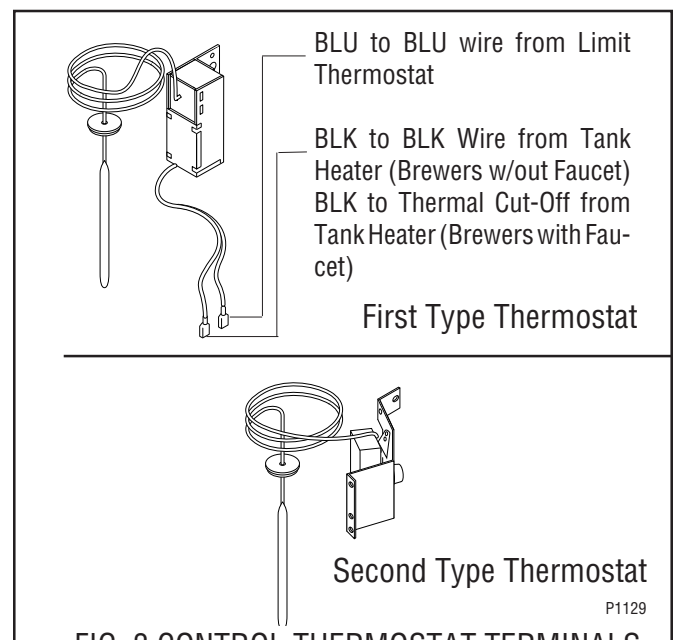
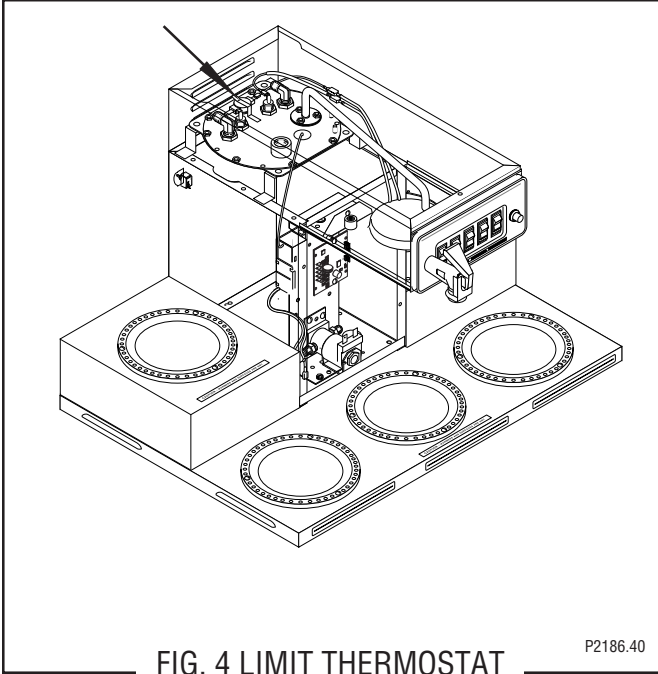

FIG. 3 CONTROL THERMOSTAT TERMINALS

SERVICE (cont.)
LIMIT THERMOSTAT



If continuity is present as described, the limit thermostat is operating properly.
If continuity is not present as described, replace the limit thermostat.

Removal and Replacement:

1. Remove all wires from limit thermostat terminals.
2. Carefully slide the limit thermostat out from under the retaining clip and remove limit thermostat.
3. Carefully slide the new limit thermostat into the retaining clip.
4. Refer to the Fig. 5 when reconnecting the wires.

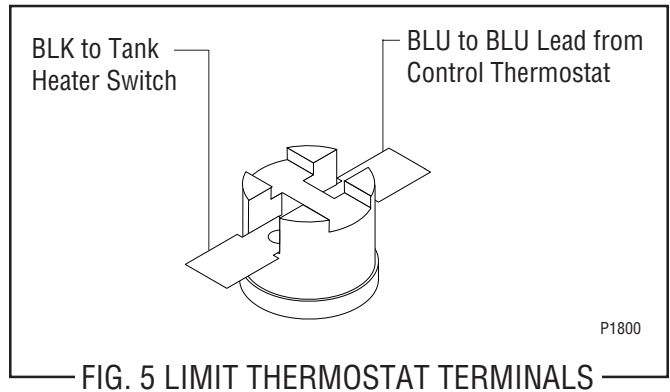

Location:

The limit thermostat is located inside the rear of the hood on the tank lid.

Test Procedures:

1. Disconnect the brewer from the power source.
2. Disconnect the blue and black wires from the limit thermostat.
3. Check for continuity across the limit thermostat terminals with a ohmmeter.

SERVICE (cont.)
ON/OFF WARMER SWITCH

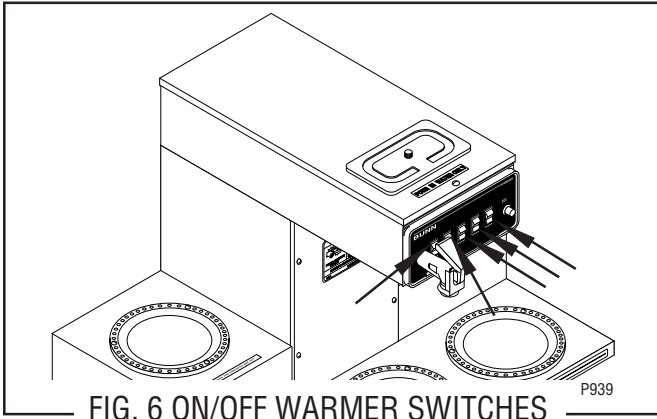

FIG. 6 ON/OFF WARMER SWITCHES

Locat

The ON/OFF switch(s) are located on the front of the hood.

Test Procedure:

1. Disconnect the brewer from the power source.
2. Viewing the switch from the back remove the white or red wire from the upper terminal and the black wire from the center terminal.
3. Check the voltage across the white wire or red wire and the black wire with a voltmeter. Connect the brewer to the power source. The indication must be:
 - a) 120 volts ac for two wire 120 volt models and three wire 120/240 volt models.
 - b) 200 to 240 volts ac for two wire 200 or 240 volt models.
4. Disconnect the brewer from the power source.

If voltage is present as described, reconnect the white or red wire and proceed to #5.

If voltage is not present as described, refer to the *Wiring Diagrams* and check the brewer wiring harness.

5. With the black wire removed, remove the wire from the lower terminal.
6. Check for continuity across the center and lower terminal with the switch in the "ON" position. Continuity must not be present when the switch is in the "OFF" position.

If continuity is present as described, reconnect the black wire to the center terminal and the remaining wire to the lower terminal.

If continuity is not present as described, replace the switch.

Removal and Replacement:

1. Remove the wires from the switch terminals.
2. Compress the clips inside the hood and gently push the switch through the opening.
3. Push the new switch into the opening and spread the clips to hold switch in the hood.
4. Refer to Fig.7 when reconnecting the wires.

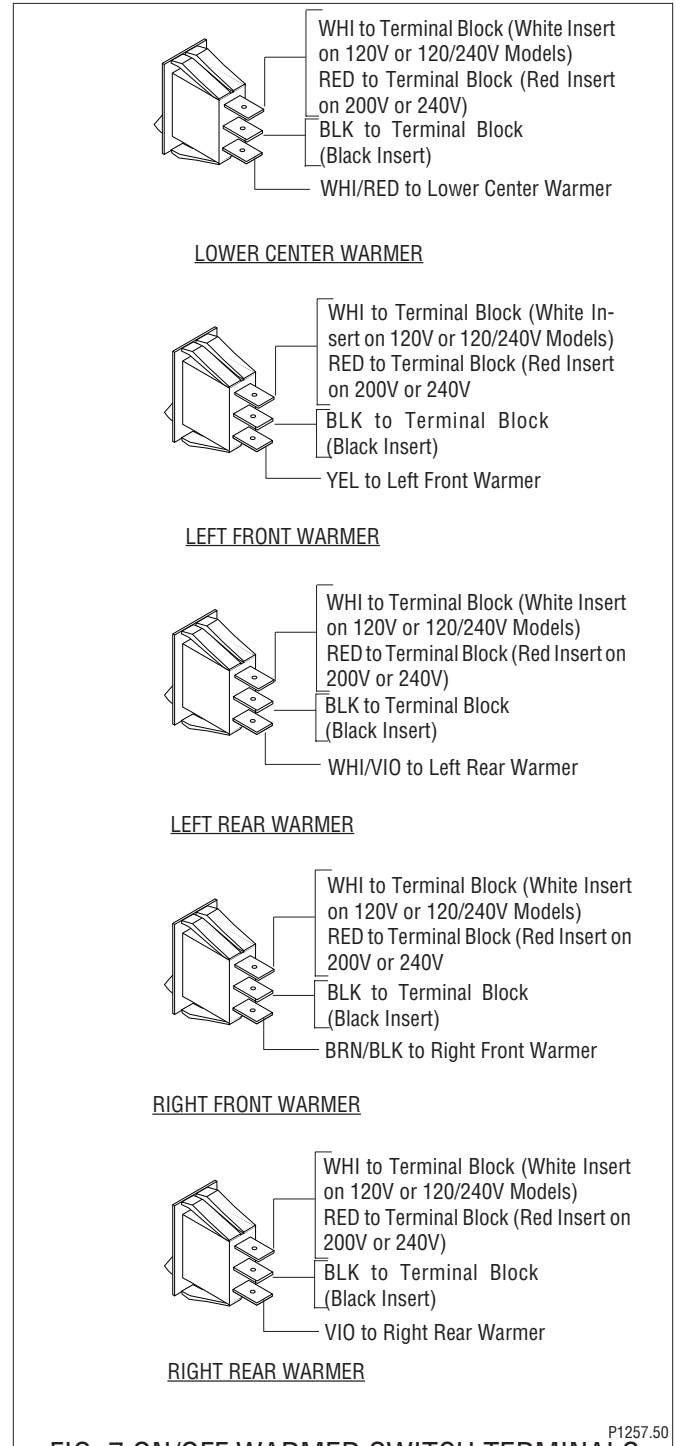

FIG. 7 ON/OFF WARMER SWITCH TERMINALS

P1257.50
 10478 061500

SERVICE (cont.)

SOLENOID VALVE

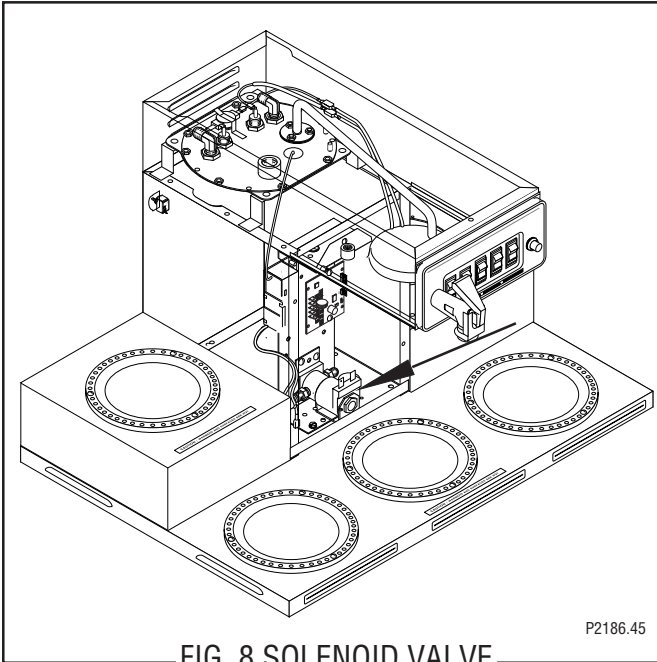

FIG. 8 SOLENOID VALVE

Location:

The solenoid valve is located inside the trunk on the lower center part of the component bracket.

Test Procedures:

1. Disconnect the brewer from the power source.
2. Disconnect the white and black wires from the solenoid valve. With the "ON/OFF" switch in the "ON" upper position press the start switch.
3. Check the voltage across the white and black wires with a voltmeter. Connect the brewer to the power source. The indication must be:
 - a) 120 volts ac for two wire 120 volt models and three wire 120/240 volt models.
 - b) 200 to 240 volts ac for two wire 200 or 240 volt models.
4. Disconnect the brewer from the power source,

If voltage is present as described, proceed to #5
If voltage is not present as described, refer to *Wiring Diagrams* and check brewer wiring harness.

5. Check for continuity across the solenoid valve coil terminals.

If continuity is present as described, reconnect the white and black wire from the timer.

If continuity is not present as described, replace the solenoid valve.

6. Check the solenoid valve for coil action. Connect the brewer to the power source. With "ON/OFF" switch in the "ON" upper position press start switch and listen carefully in the vicinity of the solenoid valve for a "clicking" sound as the coil magnet attracts.
7. Disconnect the brewer from the power source.

If the sound is heard as described and water will not pass through the solenoid valve, there may be a blockage in the water line before the solenoid valve or, the solenoid valve may require inspection for wear, and removal of waterborne particles.

If the sound is not heard as described, replace the solenoid valve.

Removal and Replacement:

1. Remove the white and black from the solenoid valve.
2. Turn off the water supply to the brewer.
3. Disconnect the water lines to and from the solenoid valve.
4. Remove the two #8-32 screws securing the solenoid mounting bracket to the component bracket. Remove solenoid bracket and solenoid valve as an assembly.
5. Remove the two #10-32 screws and lockwashers securing the solenoid valve to the solenoid bracket.
6. Using two #10-32 screws and lockwashers install new solenoid valve on solenoid mounting bracket.
7. Using two #8-32 screws install solenoid valve and bracket to the component bracket.
8. Securely fasten the water lines to and from the solenoid valve.
9. Refer to Fig. 9 when reconnecting the wires.

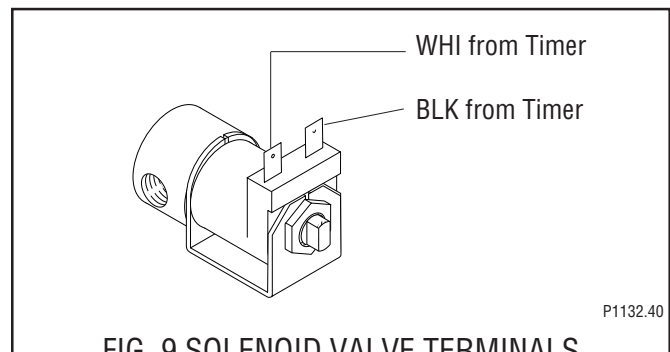
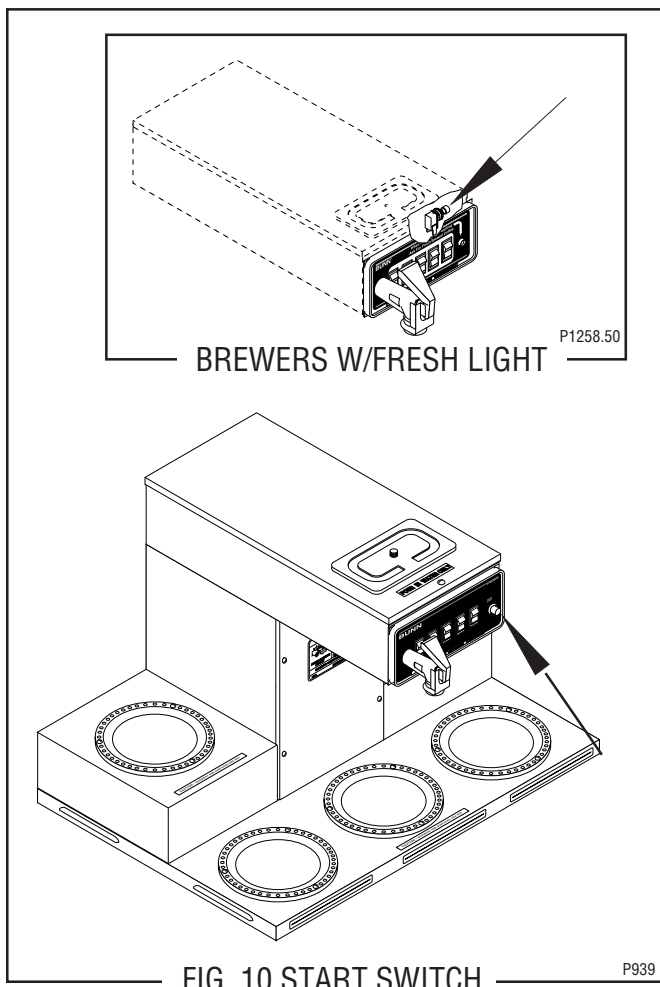

FIG. 9 SOLENOID VALVE TERMINALS

SERVICE (cont.)

START SWITCH



If continuity is present as described, reconnect the blue wire and the white/red to the switch terminals. If continuity is not present as described, replace the switch.

Removal and Replacement:

1. Remove the blue wire and white/red from the start switch.
2. Remove round retaining nut from the front of the switch and remove switch and internal tooth lockwasher from the inside of the hood.
3. Push new switch with internal tooth lockwasher through the hole in the hood and secure with round retaining nut.
4. Refer to Fig. 11 when reconnecting the wires.

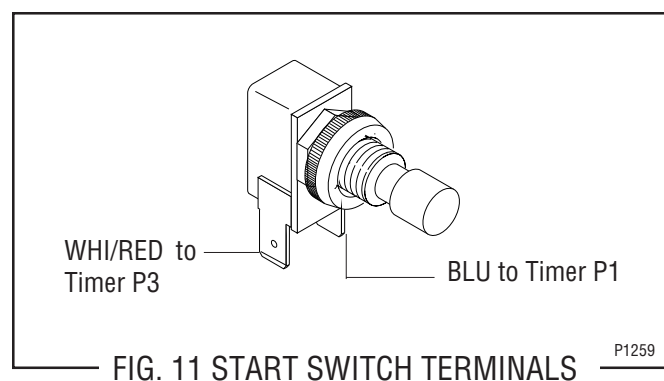

Location:

On brewers w/out fresh light the start switch is located in the right front of the hood.

On brewers w/fresh light the start switch is located on the right side of the hood.

Test Procedure:

1. Disconnect the brewer from the power supply.
2. Disconnect the blue wire and the white/red wire from the switch terminals.
3. Check for continuity across the two terminals on the switch when it is held in the "pressed-in" position. Continuity must not be present across these terminals in the released position.

SERVICE (cont.)

TANK HEATER

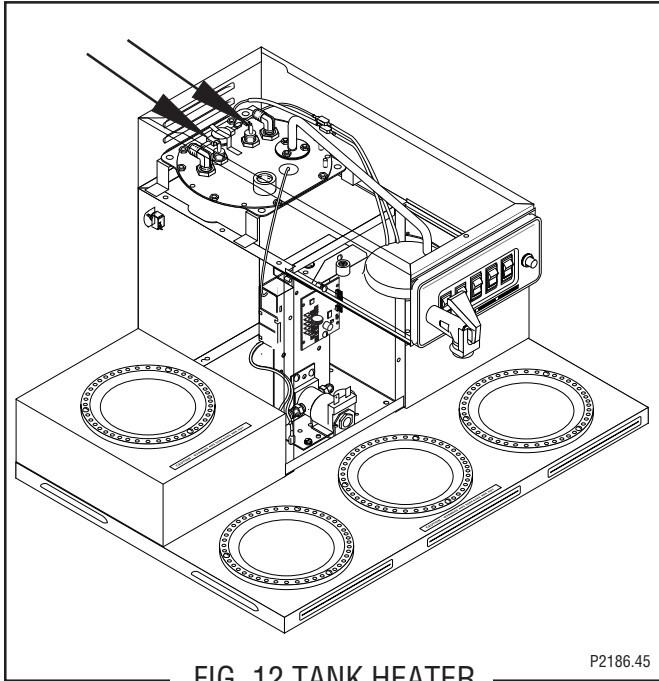

FIG. 12 TANK HEATER

Location:

The tank heater is located inside the tank and secured to the tank lid.

Test Procedures:

1. Disconnect the brewer from the power supply.
2. Check the voltage across the black and white wires on 120 volt models or the black and red wires for 120/240 volt models, 200 volt models and 240 volt models with a voltmeter. Connect the brew to the power source. The indication must be:
 - a) 120 volts ac for two wire 120 volt 20 amp models .
 - b) 240 volts ac for three wire 120/240 volt models.
 - c) 200 to 240 volts ac for two wire 200 or 240 volt models.
3. Disconnect the brewer from the power source.

If voltage is present as described, proceed to #4

If voltage is not present as described, refer to the *Wiring Diagrams* and check wiring harness.

4. Disconnect the black wire and the white wire or red

wire from the tank heater terminals.

5. Check for continuity across the tank heater terminals.

If continuity is present as described, reconnect the wires, the tank heater is operating properly.

If continuity is not present as described, replace the tank heater.

NOTE- If the tank heater remains unable to heat, remove and inspect heater for cracks in the sheath.

Removal and Replacement:

1. Disconnect the water supply tube from the fill basin.
2. Remove the tank inlet fitting securing the fill basin to the tank lid, remove fill basin and tank inlet gasket. Set all three parts aside for reassembly.
3. On brewers with faucet shut-off water supply to the brewer and disconnect the inlet and outlet water lines to the faucet coil assembly.
4. Disconnect the black wire on the limit thermostat from the tank heater switch. On late model brewers also disconnect the blue wire from the limit thermostat to the control thermostat.
5. Disconnect the black wire and the white or red wire from the tank heater terminals.
6. Remove sprayhead and the hex nut securing the sprayhead tube to the hood. Set aside for reassembly.
7. Remove the eight #8-32 nuts securing the tank lid to the tank.
8. Remove the tank lid with limit thermostat, sprayhead tube, tank heater, coil assembly and control thermostat w/bracket (early models only).
9. Remove the two hex nuts securing the tank heater to the tank lid. Remove tank heater with gaskets and discard.
10. Install new tank heater with gaskets on the tank lid and secure with two hex nuts.
11. Install tank lid with limit thermostat, sprayhead tube, tank heater, coil assembly (brewers with faucet) and control thermostat with bracket (early brewers only) using eight #8-32 hex nut.
12. Reconnect the inlet and outlet water lines to the faucet coil assembly.

SERVICE (cont.)

TANK HEATER (Cont.)

13. Secure sprayhead tube to hood using a hex nut.
14. Install sprayhead.
15. Reconnect the wires to the limit thermostat, tank heater and control thermostat. See limit thermostat and control thermostat sections in this manual when reconnecting wires.
16. Install fill basin, secure with tank inlet fitting and gasket. Insert water supply line through grommet in fill basin.
17. Refer to Fig. 13 when reconnecting the tank heater wires.

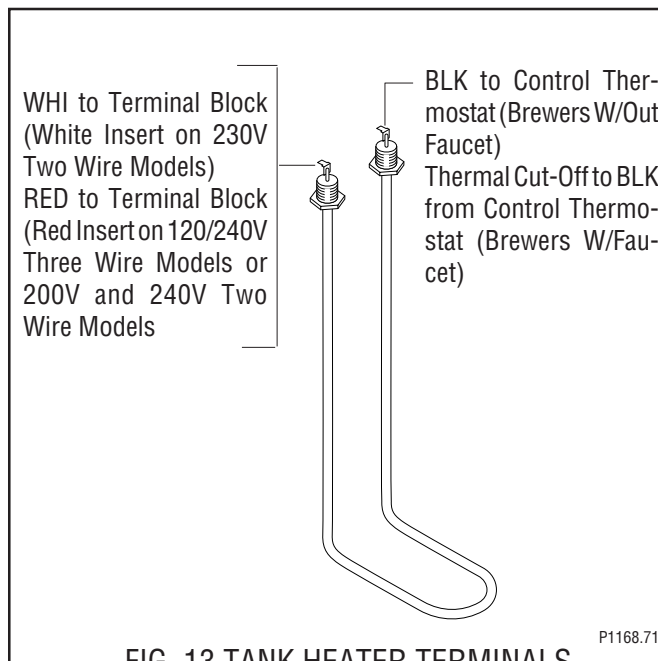

FIG. 13 TANK HEATER TERMINALS

SERVICE (cont.)

TANK HEATER SWITCH

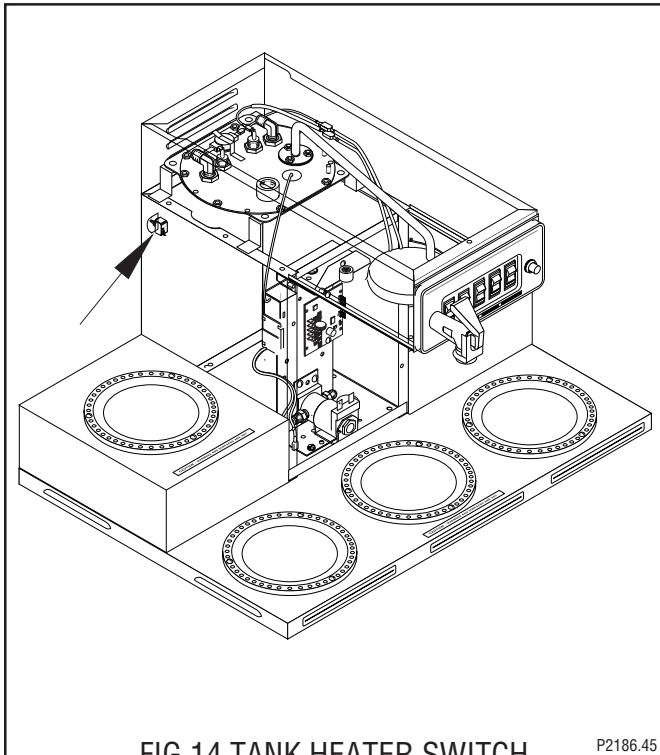

FIG 14 TANK HEATER SWITCH

P2186.45

Location:

The tank heater switch is located on the rear of the brewer on the upper left side of the trunk.

Test Procedure:

1. Disconnect the brewer from the power source.
2. Disconnect the black wire from the limit thermostat.
3. With the tank heater switch in the "ON" position and with a voltmeter, check the voltage between the black wire removed from the limit thermostat and the white wire or red wire on the tank heater. Connect the brewer to the power source. The indication must be:
 - a) 120 volts ac on two wire 120 volt models.
 - b) 240 volts ac on three wire 120/240 volt models.
 - c) 200 to 240 volts ac on 200 volt or 240 volt models.
4. Disconnect the brewer from the power source.

If voltage is present as described, proceed to #5.
If voltage is not present as described, refer to the *Wiring Diagrams* and check the brewer wiring harness.

5. With the tank heater switch in the "ON" upper position, check for continuity between the black wire removed from the limit thermostat and the black insert on the terminal block. Continuity should not be present in the "OFF" lower position.

If continuity is present as described, the tank heater switch is operating properly.

If continuity is not present as described, replace the tank heater switch.

Removal and Replacement:

1. Shut off and disconnect the incoming water supply to the brewer.
2. On automatic brewers gently remove the fill tube from back of fill basin.
3. Remove the tank inlet fitting securing fill basin the tank lid. Remove fill basin and gasket. Set all three parts aside for reassembly.
4. On brewers with faucets, disconnect the water supply to coil assembly and remove the tube from the tank to the faucet.
5. Remove sprayhead and hex nut securing sprayhead tube to the hood. Set aside for reassembly.
6. Disconnect the wires on the limit thermostat and the tank heater and the control thermostat (early models).
7. Gently pull the thermostat sensor and grommet from the tank lid.
8. Insert a tube to the bottom of the tank and syphon ALL of the water out. BUNN-O-MATIC has #12440.0000 syphon assembly available for this purpose.
9. Remove the two #8-32 screws securing the tank assembly to the hood.
10. Lift tank and components out as an assembly and set aside for reassembly.
11. Disconnect the two black wires from the tank heater switch.
12. Remove the plastic facenut, hex facenut and the switch indicator/guard bracket that secures tank heater switch to the rear of the brewer. Remove switch and discard.
13. Insert new tank heater switch through the hole in the upper left rear of the trunk and secure with switch indicator/guard bracket, hex facenut and plastic facenut.

SERVICE (cont.)

TANK HEATER SWITCH (cont.)

14. Reconnect the two black wires to the tank heater switch terminals.
15. Set tank assembly inside the hood on mounting brackets and secure with two #8-32 screws.
16. Reconnect the wires to the limit thermostat, tank heater and the control thermostat. Refer to limit thermostat, tank heater and control thermostat sections in this manual when reconnecting wires.
17. Brewers with faucet reinstall the faucet tube and reconnect the water supply tube to the coil assembly.
18. Secure the sprayhead tube to the hood using hex nut.
19. Install sprayhead.
20. Install fill basin, inlet gasket and secure to tank lid with tank inlet fitting.
21. Carefully install water fill tube into the back of the fill basin.
22. Reconnect and turn on the incoming water supply.
23. Refer to Fig. 15 when reconnecting the wires.

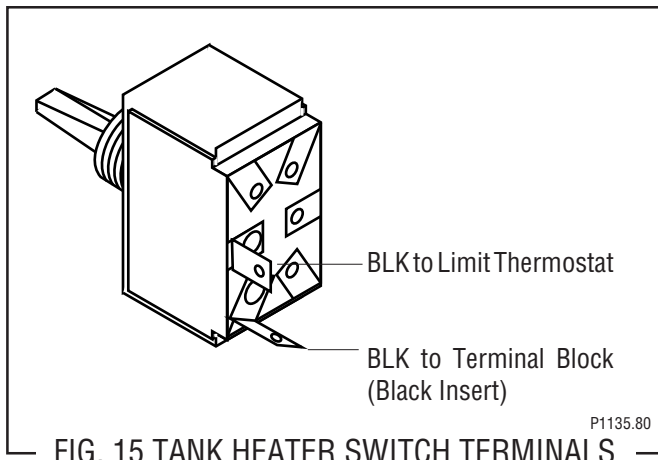

SERVICE (cont.)

THERMAL CUT-OFF (Brewers W/Faucet)

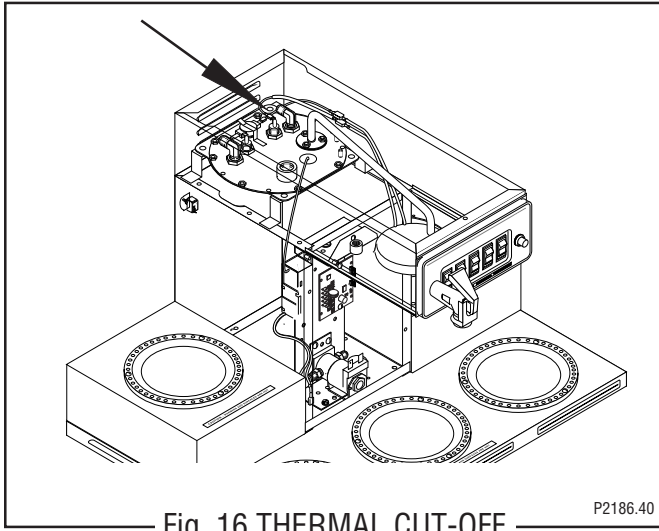

Location:

The thermal cut-off is located inside the hood connected to the tank heater.

Test Procedures:

1. Disconnect the brewer from the power source.
2. Disconnect the thermal cut-off from the tank heater and the black wire from the control thermostat.
3. Check for continuity across thermal cut-off terminals with an ohmmeter.

If continuity is present as described, the thermal cut-off is operating properly.

If continuity is not present as described, replace the thermal cut-off.

Removal and Replacement:

1. Disconnect the thermal cut-off from the tank heater and the black lead from the control thermostat.
2. Install new thermal cut-off.
3. Refer to Fig. 17 when reconnecting wires.

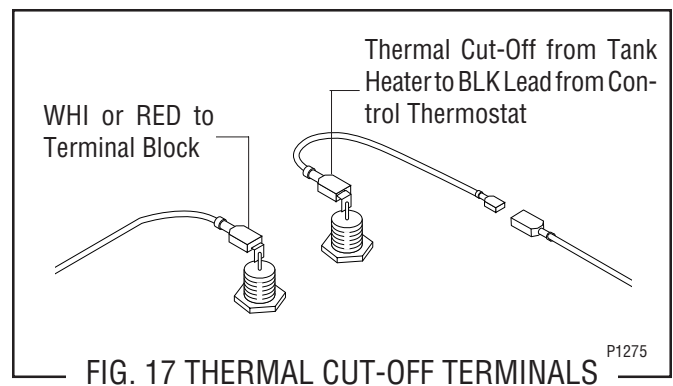

SERVICE (cont.)

TIMER (Early Models)

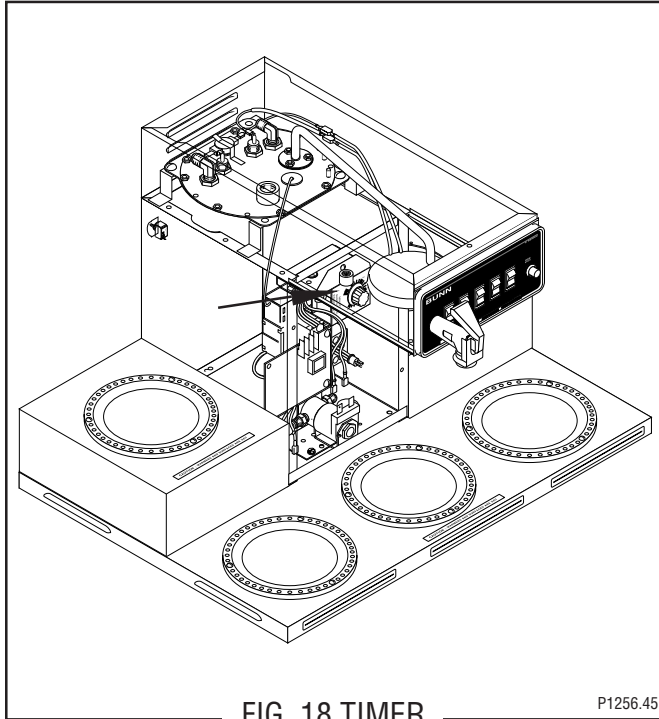

FIG. 18 TIMER

P1256.45

Location:

The timer is located inside the front of the trunk on the upper right side of component bracket.

Test Procedure.

1. Disconnect the brewer from the power source.
2. Disconnect the polarized, three pin connector from the brewer wiring harness and rotate the brew timer dial fully counterclockwise.
3. With a voltmeter, check the voltage across sockets P2 & P3 (white and white/red wires) of the female connector when the "ON/OFF" switch is in the "ON" position (upper). Connect the brewer to the power source. The indication must be:
 - a) 120 volts ac for two wire 120 volt models and three wire 120/240 volt models.
 - b) 200 to 240 volts ac on two wire 200 volt or 240 volt models.
4. Disconnect the brewer from the power source.

If voltage is present as described, proceed to #5. If voltage is not present as described, refer to the Wiring Diagrams and check the brewer wiring harness.

5. Check the voltage across the sockets P1 & P2 (blue and white wires) of the female connector with a voltmeter when the "ON/OFF" switch is in the "ON" position (upper) and start switch pressed. Connect the brewer to the power source. The indication must be:
 - a) 120 volts ac for two wire 120 volt models and three wire 120/240 volt models.
 - b) 200 to 240 volts ac for two wire 200 volt or 240 volt models.
6. Disconnect the brewer from the power source.
7. Reconnect the three pin connector from main wiring harness to the timer.

If voltage is present as described, proceed to #8

If voltage is not present as described, refer to Wiring Diagrams and check the brewer wiring harness.

8. Disconnect the black and white wires from the solenoid.
9. With a voltmeter, check the voltage across the black and white wires when the "ON/OFF" switch is in the "ON" position (upper) and the "START" switch is pressed to the "START" position and released. Connect the brewer to the power source. The indication must be:
 - a) 120 volts ac for approximately 20 seconds for two wire 120 volt models and three wire 120/240 volt models.
 - b) 200 to 240 volts ac for approximately 20 seconds for two wire 200 volt or 240 volt models.

SERVICE (cont.)

TIMER (cont.)

If voltage is present as described, the brew timer is operating properly. Reset the timer dial as required, to obtain the desired brew volume.

If voltage is not present as described, replace the timer.

Removal and Replacement:

1. Separate all connectors between the brewer wiring harness and the timer.
2. Remove the one #8-32 screw securing timer to component bracket.
3. Install new timer circuit board as described in Late Model Timer section on the following pages.
4. Refer to Fig. 21 when reconnecting the wires.
5. Install the Timer Setting decal provided with the replacement timer kit, below the schematic on the inside of the front access panel.
6. Adjust the timer as required. Refer to Late Model Timer section on the following pages.

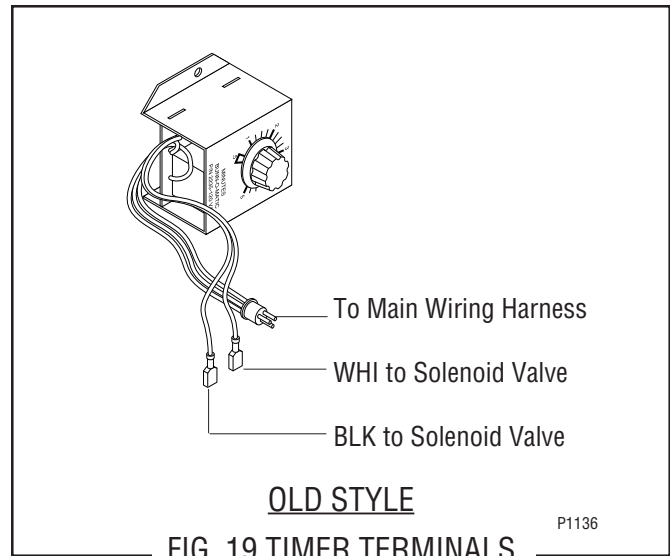

FIG. 19 TIMER TERMINALS

SERVICE (cont.)

DIGITAL BREW TIMER (Late Models)

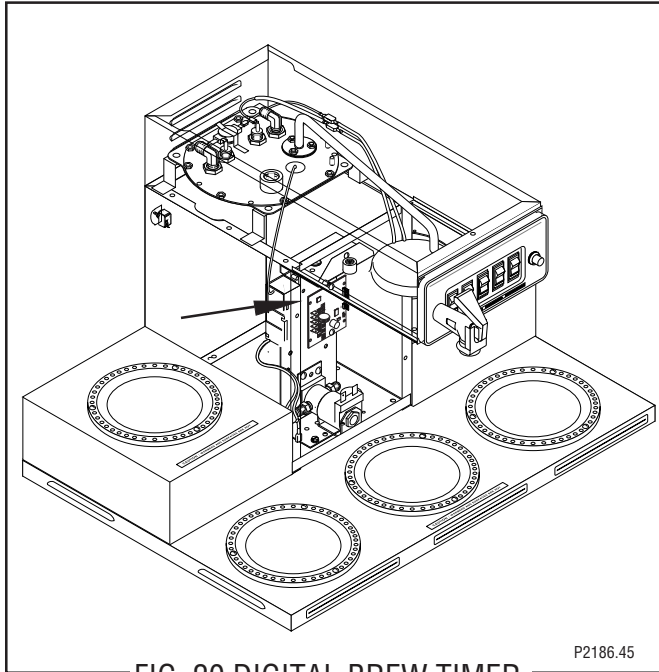

FIG. 20 DIGITAL BREW TIMER

Location:

The timer is located inside the front of the trunk on the upper right side of component bracket.

Test Procedure

NOTE: Do not remove or install wires while timer board is installed. Pressure applied to one side may cause damage to the board.

1. Disconnect the brewer from the power source and remove the front access panel.
2. Remove the two #8-32 screws securing circuit board to the mounting bracket.
3. Remove circuit board and spacers (as required).
4. With a voltmeter, check the voltage across terminals TL1 and TL2 when the "ON/OFF" switch is in the "ON" position. Connect the brewer to the power source. The indication must be:
 - a) 120 volts ac for two wire 120 volt models and three wire 120/240 volt models.
 - b) 200 to 240 volts ac on two wire 200 volt or 240 volt models.
5. Disconnect the brewer from the power source.

If voltage is present as described, proceed to #6.

If voltage is not present as described, refer to the *Wiring Diagrams* and check the brewer wiring harness.

6. Disconnect the white/blue wire from terminal TL3 and the blue/black wire from terminal TL5. With a voltmeter, check for continuity across the two wires when the "ON/OFF" switch is in the "ON" position (upper) and the START switch is pressed. Connect the brewer to the power source. The indication must be:
 - a) 120 volts ac for two wire 120 volt models and three wire 120/240 volt models.
 - b) 200 to 240 volts ac for two wire 200 volt or 240 volt models.

If continuity is present as described, reconnect the wires and proceed to #7.

If continuity is not present as described, refer to the *Wiring Diagrams* and check the brewer wiring harness.

7. With a voltmeter, check the voltage across terminals TL1 and TL4 when the "ON/OFF" switch is in the "ON" position. Connect the brewer to the power source. The indication must be 0 volts.

If voltage is as described, proceed to #8.

If voltage is not as described, disconnect the brewer from the power source and replace the timer.

8. With a voltmeter, check the voltage across terminals TL1 and TL4 when the "ON/OFF" switch is in the "ON" position. Connect the brewer to the power source and press the "START" switch. The indication must be as follows:
 - a) 120 volts ac for two wire 120 volt models and three wire 120/240 volt models.
 - b) 200 to 240 volts ac on two wire 200 volt or 240 volt models.

If voltage is present as described, the brew timer is operating properly. Reset the timer as required, to obtain the desired brew volume.

If voltage is not present as described, disconnect the brewer from the power source and replace the timer.

Removal and Replacement:

1. Remove the two #8-32 screws securing circuit board to the mounting bracket.
2. Remove circuit board and spacers (as required).
3. Remove all wires from the timer.

SERVICE (cont.)

DIGITAL BREW TIMER (Late Models)(cont.)

4. Attach all wires to the replacement timer board prior to installation to the component mounting bracket. Refer to FIG. 21 when reconnecting the wires.
5. Install new circuit board with spacers (as required) to the component mounting bracket.
6. Adjust the timer as described below.

Timer Setting:

NOTE: Prior to setting or modifying volumes, check that the brewer is connected to water supply, the tank is properly filled, and a funnel and server are in place.

NOTE: All volume settings must be done with the sprayhead installed.

1. **Modifying brew volumes.** To modify a brew volume, first check that the SET/LOCK switch is in the "SET" position on the circuit board.

To increase a brew volume, place the ON/OFF switch in the "ON" position, press and hold the START switch until three clicks are heard. Release the switch and press it again one or more times. (Failure to release the switch within two seconds after the third click causes the volume setting to be aborted and previous volume setting will remain in memory) Each time the switch is pressed, two seconds are added to the brew time period. Allow the brew cycle to finish in order to verify that the desired volume has been achieved.

To decrease a brew volume, place the ON/OFF switch in the "ON" position, press and release the START switch once for every two-second interval to be removed from the total brew time period; then immediately press and hold down the START switch until three clicks are heard. Release the switch. (Failure to release the switch within two seconds after the third click causes the volume setting to be aborted and previous volume setting will remain in memory). Allow the brew cycle to finish in order to verify that the desired volume has been achieved.

2. **Setting brew volumes.** To set a brew volume, first check that the SET/LOCK switch is in the "SET" position on the circuit board. Place the ON/OFF switch in the "ON" position, press and hold the START switch

until three distinct clicks are heard and then release the switch. (Failure to release the switch within two seconds after the third click causes the volume setting to be aborted and previous volume setting will remain in memory.

View the level of the liquid being dispensed. When the desired level is reached, turn the ON/OFF switch to "OFF".

NOTE: Several ounces of water will continue to syphon from the tank after turning the switch "OFF". The brewer remembers this volume and will continue to brew batches of this size until the volume setting procedure is repeated.

NOTE: When brewing coffee, volume will decrease due to absorption by the coffee grounds.

3. **Setting programming disable feature.** If it becomes necessary to prevent anyone from changing brew time once programmed, you can set the SET/LOCK switch to the "LOCK" position. This will prevent any further programming until switch is once again put into the "SET" position.

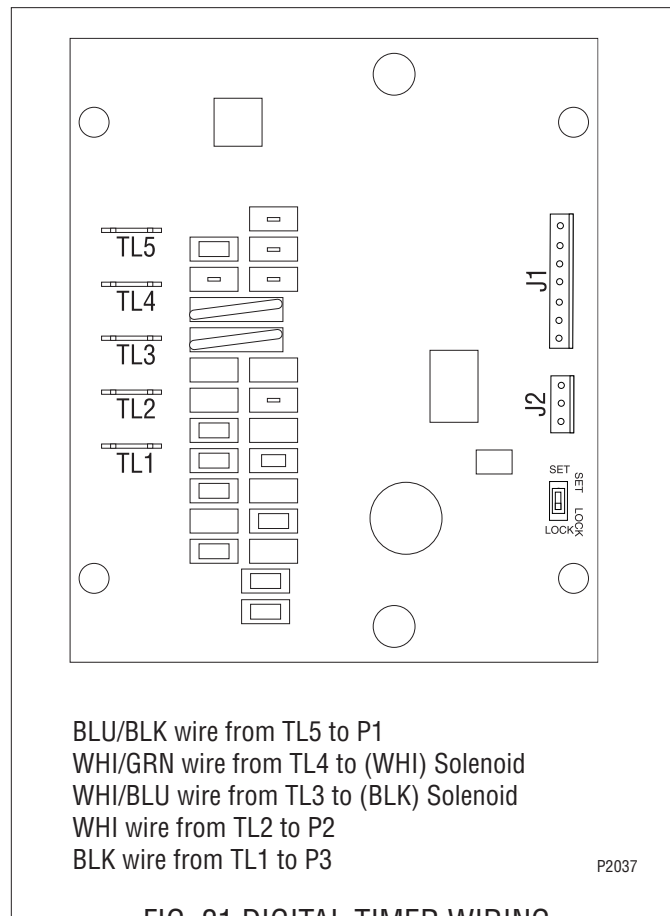

FIG. 21 DIGITAL TIMER WIRING

SERVICE (cont.)

WARMER ELEMENT(S)

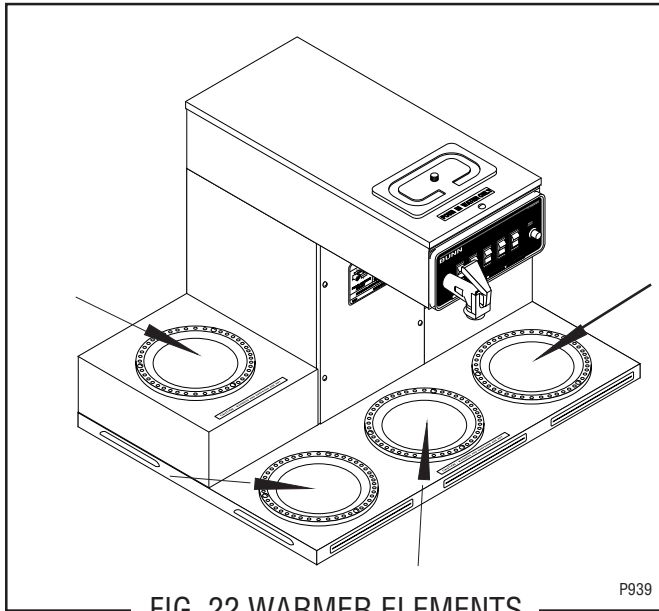

FIG. 22 WARMER ELEMENTS

Location:

The warmer elements are located under the warmer plates.

Test Procedures:

1. Disconnect the brewer from the power source.
2. Use the white or red wire to the terminal block and the white/red, yellow, white/violet, brown/black or violet wire to the "ON/OFF" switch.
3. With a voltmeter, check voltage across the white or red and white/red, yellow, white/violet, brown/black or violet with the "ON/OFF" switch in the "ON" position. The indication must be:
 - a) 120 volts ac for two wire 120 volt models and three wire 120/240 volt models.
 - b) 200 to 240 volts ac for two wire 200 or 240 volt models.
4. Disconnect the brewer from the power source.

If voltage is present as described, proceed to #5.
If voltage is not present as described, refer to wiring diagrams and check brewer wiring harness.

5. Check the continuity across the two terminals on the warmer element.

If continuity is present as described, reconnect the wires on the warmer element.

If continuity is not present as described, replace the warmer element.

Removal and Replacement:

1. Remove the three #4-40 screws securing the warmer assembly to the brewer.
2. Lift the warmer assembly from the brewer.
3. Disconnect the two wires from the warmer element terminals.
4. Remove the two #8-32 nuts securing the warmer element to the warmer plate.
5. Securely install new warmer element.
6. Reconnect the two wires to warmer element terminals.
7. Securely install warmer assembly on the brewer.
8. Refer to Fig. 23 when reconnecting the wires.

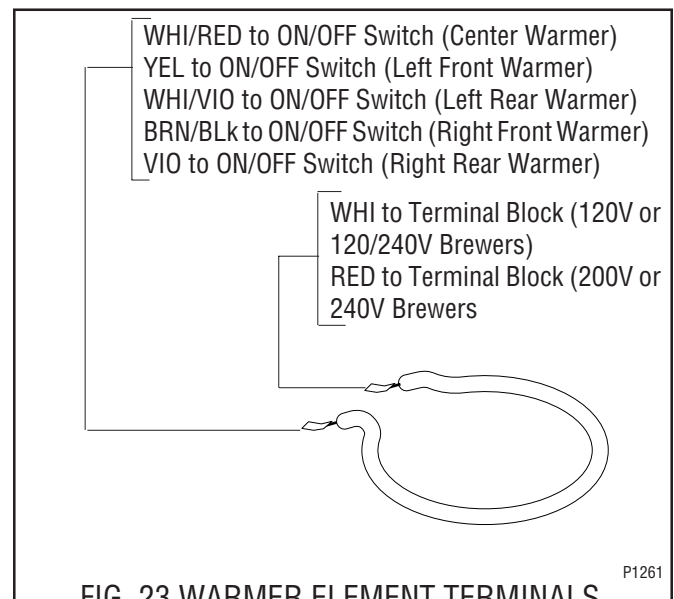
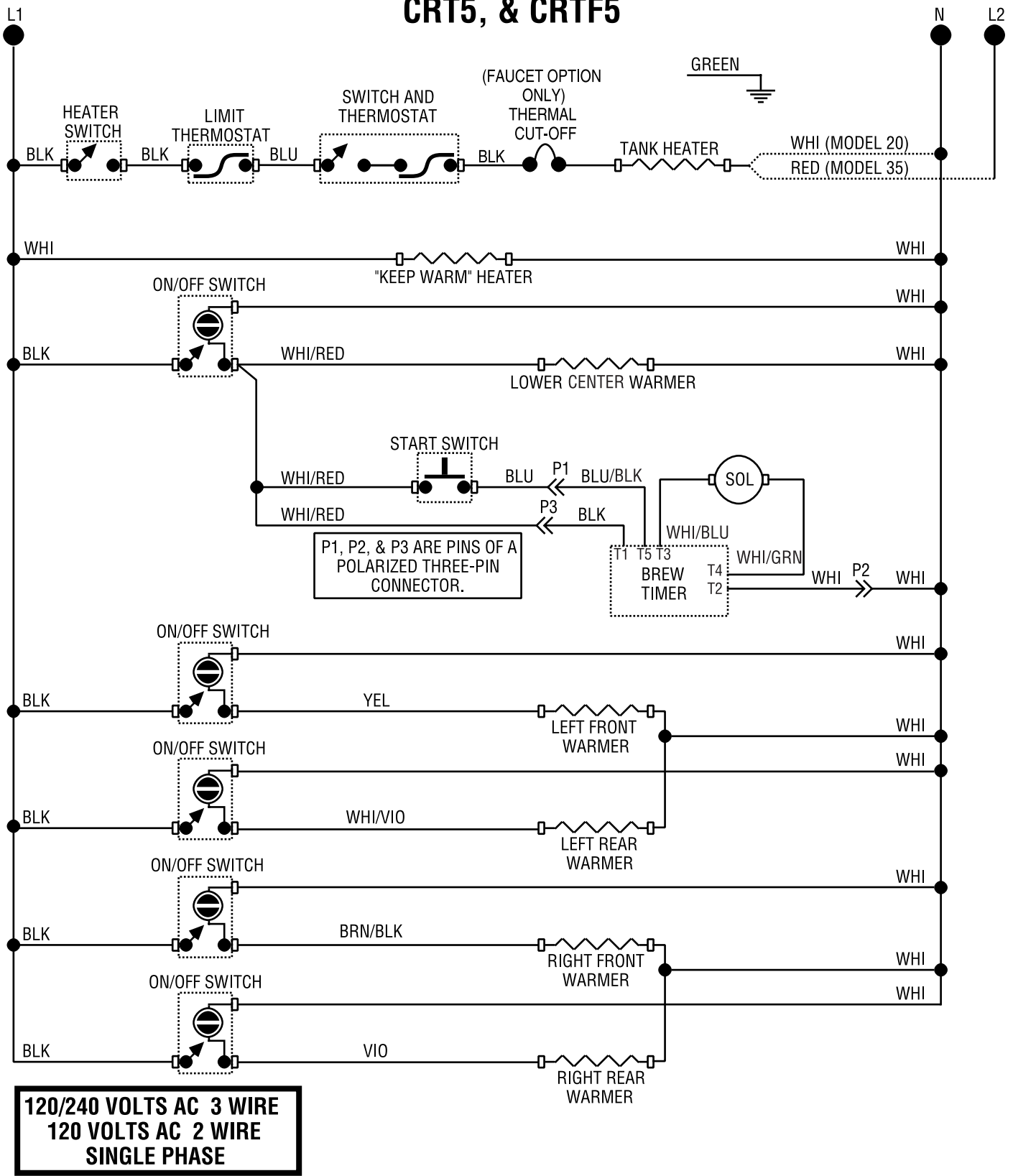
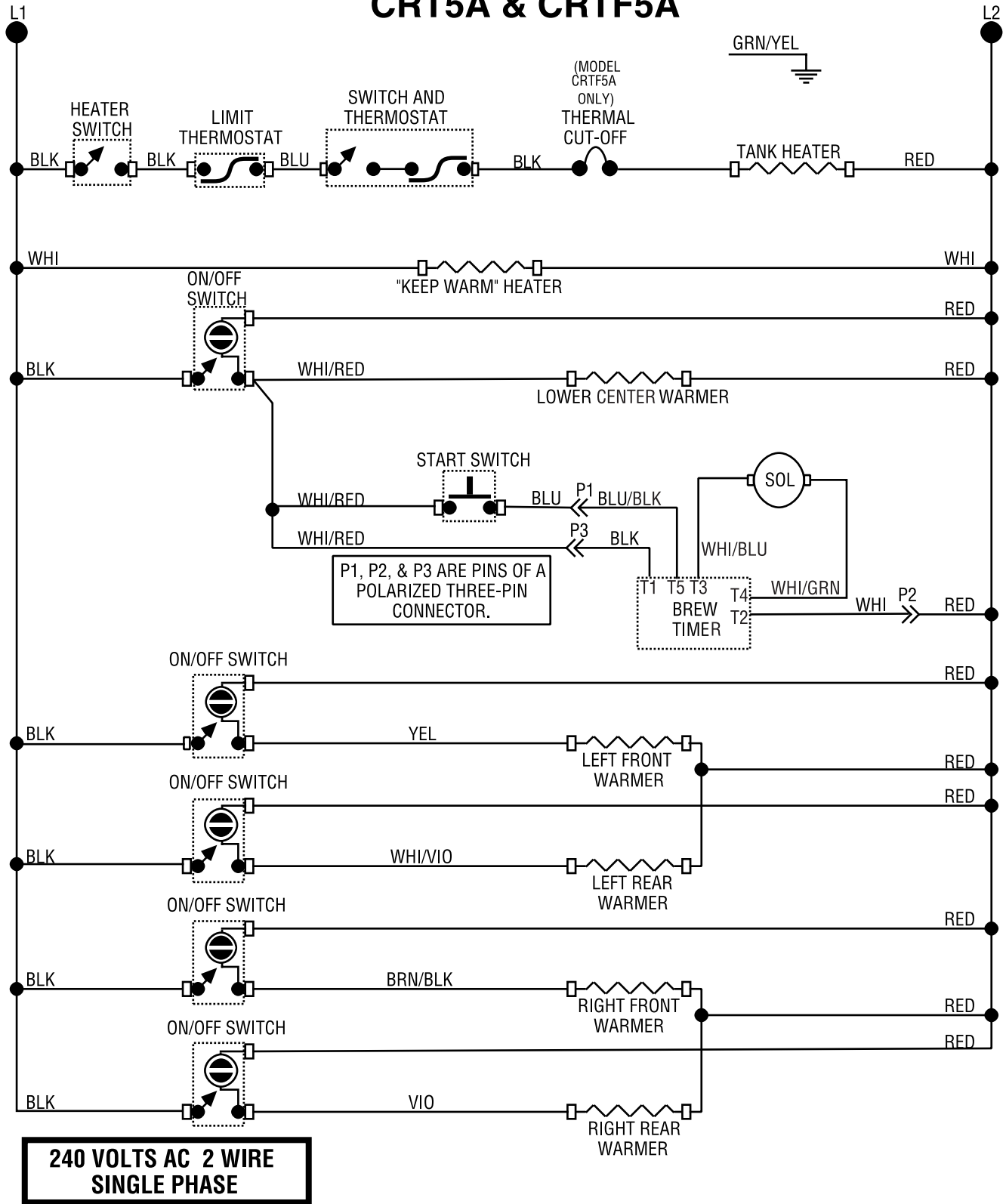

FIG. 23 WARMER ELEMENT TERMINALS

SCHEMATIC WIRING DIAGRAM CRT5, & CRTF5



SCHEMATIC WIRING DIAGRAM CRT5A & CRTF5A



SCHEMATIC WIRING DIAGRAM CRT5B & CRTF5B

