

WELLS BLOOMFIELD, LLC

2 ERIK CIRCLE, P. O. Box 280 Verdi, NV 89439
telephone: 775-689-5707 fax: 775-689-5976
www.wellsbloomfield.com



*Model 9012 Brewers
with optional
8900-Series Glass Decanters*

**OWNERS MANUAL
for
INTEGRITY™**

**DECANTER
COFFEE BREWERS**

MODELS

9010 9012

9016

Includes:

**Installation
Use & Care
Servicing Instructions**

PRINTED IN UNITED STATES OF AMERICA

WARRANTY STATEMENT

All electrical equipment manufactured by WELLS BLOOMFIELD, LLC is warranted against defects in materials and workmanship for a period of one year from the date of original installation or eighteen (18) months from the date of shipment from our factory, whichever comes first, and is for the benefit of the original purchaser, except that:

- a. airpots carry a 30 day parts warranty only.
- b. dispensers; i.e., tea and coffee carry a 90 days parts warranty only, excludes decanters.

THE FOREGOING OBLIGATION IS EXPRESSLY GIVEN IN LIEU OF ANY OTHER WARRANTIES, EXPRESSED OR IMPLIED, INCLUDING ANY IMPLIED WARRANTY OF MERCHANTABILITY OR FITNESS FOR A PARTICULAR PURPOSE, WHICH ARE HEREBY EXCLUDED.

WELLS BLOOMFIELD, LLC SHALL NOT BE LIABLE FOR INDIRECT, INCIDENTAL OR CONSEQUENTIAL DAMAGES OR LOSSES FROM ANY CAUSE WHATSOEVER.

This warranty is void if it is determined that upon inspection by an Authorized Service Agency that the equipment has been modified, misused, misapplied, improperly installed, or damaged in transit or by fire, flood or act of God.

It also does not apply if the serial nameplate has been removed or unauthorized service personnel perform service. The prices charged by Bloomfield Industries for its products are based upon the limitations in this warranty. Seller's obligation under this warranty is limited to the repair of defects without charge by a Bloomfield Authorized Service Agency or one of its sub-agencies. This service will be provided on customer's premises for non-portable models. Portable models (a device with a cord and plug) must be taken or shipped to the closest Authorized Service Agency, transportation charges prepaid, for services.

In addition to restrictions contained in this warranty, specific limitations are shown below (Additional Warranty Exclusions). Bloomfield Industries Authorized Service Agencies are located in principal cities.

This warranty is valid in the United States and void elsewhere. Please consult your classified telephone directory or your food service equipment dealer; or, for information and other details concerning warranty, write to:

**Service Parts Department
Wells Bloomfield, LLC
P.O. Box 280
Verdi, NV 89439**

Phone: (775) 689-5707

Fax: (775) 689-5976

SERVICE POLICY AND PROCEDURE GUIDE ADDITIONAL WARRANTY EXCLUSIONS

1. Resetting of safety thermostats, circuit breakers, overload protectors, or fuse replacements unless warranted conditions are the cause.
2. All problems due to operation at voltages other than specified on equipment nameplates; conversion to correct voltage must be the customer's responsibility.
3. All problems due to electrical connections not made in accordance with electrical code requirements and wiring diagrams supplied with the equipment.
4. Replacement of items subject to normal wear, to include such items as knobs and light bulbs. Normal maintenance functions including adjustment of thermostats, microswitches, and replacement of fuses and indicating lights are not covered under warranty.
5. All problems due to inadequate water supply, such as fluctuating, or high or low water pressure.
6. All problems due to mineral/calcium deposits, or contamination from chlorides/chlorines. De-liming is considered a preventative maintenance function and is not covered by warranty.
7. Full use, care and maintenance instructions are supplied with each machine. Those miscellaneous adjustments noted are customer responsibility. Proper attention will prolong the life of the machine.
8. Travel mileage is limited to sixty (60) miles from an authorized Service Agency or one of its sub-agencies.
9. All labor shall be performed during normal working hours. Overtime premium shall be charged to the customer.
10. All genuine Bloomfield replacement parts are warranted for ninety (90) days from date of purchase on non-warranted equipment. **Any use of non-genuine Bloomfield parts completely voids any warranty.**
11. Installation, labor and job check-out are not considered warranty.
12. Charges incurred by delays, waiting time or operating restrictions that hinder the service technicians ability to perform services are not covered by warranty. This includes institutional and correctional facilities.

SHIPPING DAMAGE CLAIMS PROCEDURE

NOTE: For your protection, please note that equipment in this shipment was carefully inspected and packaged by skilled personnel before leaving the factory. Upon acceptance of this shipment, the transportation company assumes full responsibility for its safe delivery.

IF SHIPMENT ARRIVES DAMAGED:

1. **VISIBLE LOSS OR DAMAGE:** Be certain that any visible loss or damage is noted on the freight bill or express receipt, and that the note of loss or damage is signed by the delivery person.
2. **FILE CLAIM FOR DAMAGE IMMEDIATELY:** Regardless of the extent of the damage.

3. **CONCEALED LOSS OR DAMAGE:** if damage is unnoticed until the merchandise is unpacked, notify the transportation company or carrier immediately, and file "CONCEALED DAMAGE" claim with them. This must be done within fifteen (15) days from the date the delivery was made to you. Be sure to retain the container for inspection.

Wells Bloomfield cannot assume liability for damage or loss incurred in transit. We will, however, at your request, supply you with the necessary documents to support your claim.

TABLE OF CONTENTS

WARRANTY STATEMENT	xi	Thank You for purchasing this Wells Bloomfield appliance.
SPECIFICATIONS	1	
FEATURES & OPERATING CONTROLS	2	
PRECAUTIONS & GENERAL INFORMATION	3	Proper installation, professional operation and consistent maintenance of this appliance will ensure that it gives you the very best performance and a long, economical service life.
AGENCY APPROVAL INFORMATION	3	
INSTALLATION INSTRUCTIONS	4	
OPERATION	6	
BREWING COFFEE	8	
CLEANING INSTRUCTIONS	9	
TROUBLESHOOTING SUGGESTIONS	10	This manual contains the information needed to properly install this appliance, and to use, care for and maintain or repair the appliance in a manner which will ensure its optimum performance.
SERVICING INSTRUCTIONS	11	
Deliming Instructions	16	
EXPLODED VIEWS & PARTS LISTS	18	
WIRING DIAGRAMS	22	

SPECIFICATIONS

MODEL	STYLE	VOLTS	WATTS	AMPS 1 ϕ	POWER SUPPLY CORD
9010	3W IN-LINE, FAUCET	120	2300	19	NEMA 5-20P
9012	3W IN-LINE, FAUCET	120	1800	15	NEMA 5-15P
*9012CA	3W IN-LINE, FAUCET	120	1500	12.5	NEMA 5-15P
9016	3W IN-LINE, FAUCET	120/240	3800	17	NOT PROVIDED
9016EX	3W IN-LINE, FAUCET	220-240	3800	16.5	NOT PROVIDED

* 120V Canadian units are 1500 watts maximum.

FEATURES AND OPERATING CONTROLS

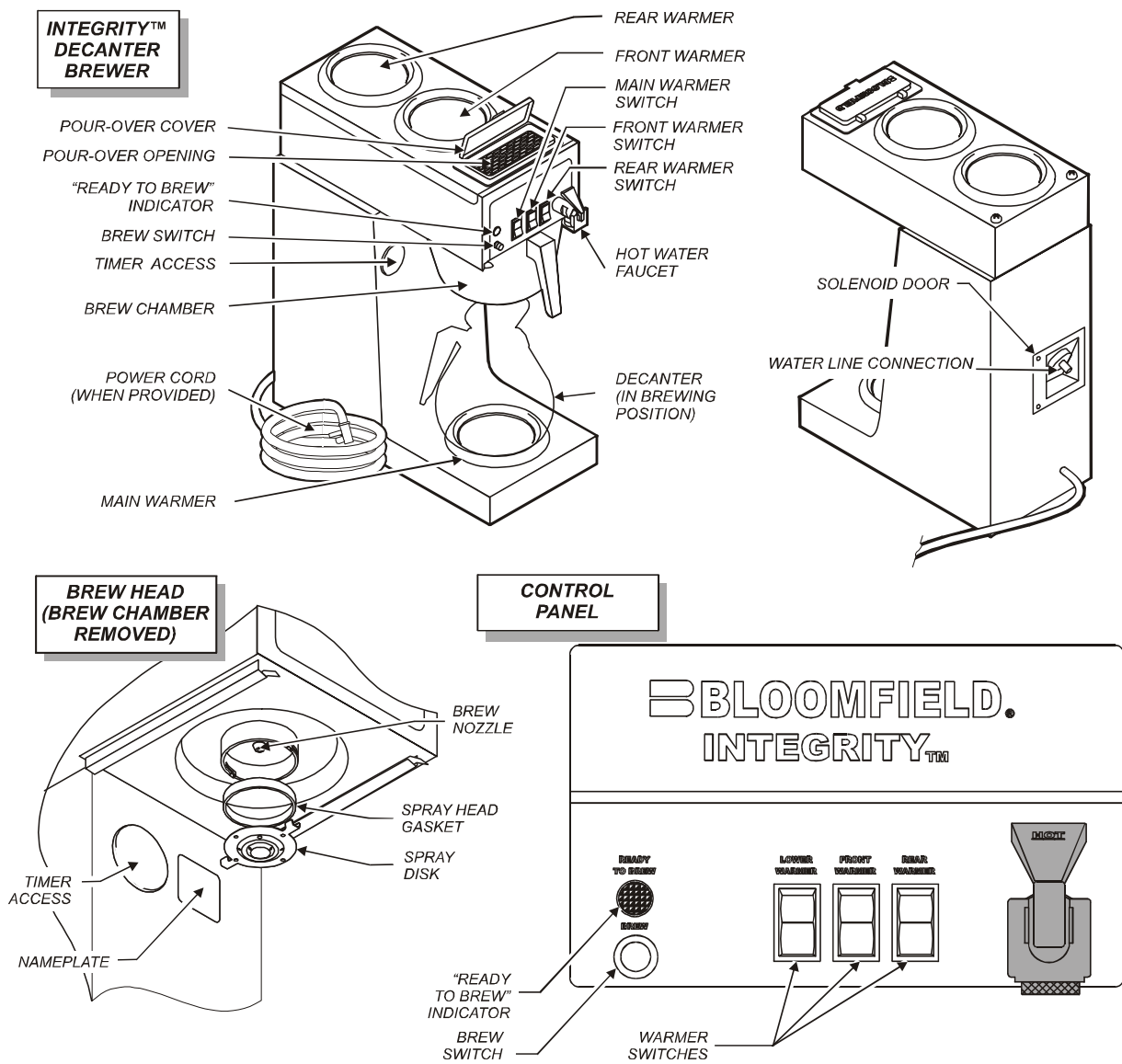

Fig. 1 Features & Operating Controls

601 75815 Owners Manual Integrity™ Decanter Brewers

PRECAUTIONS AND GENERAL INFORMATION



WARNING: ELECTRIC SHOCK HAZARD

All servicing requiring access to non-insulated components must be performed by qualified service personnel. Do not open any access panels which require the use of tools. Failure to heed this warning can result in electrical shock.



WARNING: INJURY HAZARD

All installation procedures must be performed by qualified personnel with full knowledge of all applicable electrical and plumbing codes. Failure could result in property damage and personal injury.



WARNING: ELECTRIC SHOCK HAZARD

Brewer must be properly grounded to prevent possible shock hazard. DO NOT assume a plumbing line will provide such a ground. Electrical shock will cause death or serious injury.



WARNING: BURN HAZARD

This appliance dispenses very hot liquid. Serious bodily injury from scalding can occur from contact with dispensed liquids.

This appliance is intended for commercial use only.

This appliance is intended for use to brew beverage products for human consumption. No other use is recommended or authorized by the manufacturer or its agents.

This appliance is intended for use in commercial establishments, where all operators are familiar with the appliance use, limitations and associated hazards. Operating instructions and warnings must be read and understood by all operators and users.

Except as noted, this piece of equipment is made in the USA and has American sizes on hardware. All metric conversions are approximate and can vary in size.

The following trouble shooting, component views and parts lists are included for general reference, and are intended for use by qualified service personnel.

This manual should be considered a permanent part of this appliance. The manual must remain with the appliance if it is sold or moved to another location.



CAUTION: EQUIPMENT DAMAGE

DO NOT plug in or energize this appliance until all *Installation Instructions* are read and followed. Damage to the Brewer will occur if these instructions are not followed.



CAUTION: BURN HAZARD

Exposed surfaces of the appliance, brew chamber and decanter may be HOT to the touch, and can cause serious burns.

AGENCY APPROVAL INFORMATION

This brewer is  and  listed under UL file E9253.

This brewer meets  Standard 4 only when installed, operated and maintained in accordance with the enclosed instructions.



E9253



E9253



STD 4

INSTALLATION INSTRUCTIONS

READ THIS CAREFULLY BEFORE STARTING THE INSTALLATION

IMPORTANT:

To enable the installer to make a quality installation and to minimize installation time, the following suggestions and tests should be done before the actual unit installation is started:



CAUTION: EQUIPMENT DAMAGE

DO NOT plug in or energize this appliance until all Installation Instructions are read and followed.
Damage to the Brewer will occur if these instructions are not followed.



CAUTION: UNSTABLE EQUIPMENT HAZARD

It is very important for safety and for proper operation that the brewer is level and stable when standing in its final operating position. Provided adjustable, non-skid legs must be installed at each corner of the unit. Failure to do so will result in movement of the brewer which can cause personal injury and/or damage to brewer.

NOTE: Water supply inlet line must meet certain minimum criteria to insure successful operation of the brewer. Bloomfield recommends 1/4" copper tubing for installation of less than 12 feet and 3/8" for more than 12 feet from a 1/2" water supply line.

Unpack the unit. Inspect all components for completeness and condition. Ensure that all packing materials have been removed from the unit.

Verify that the Spray Head Gasket and Spray Disk are properly installed.

LEVELING THE UNIT

Verify that an adjustable leg is installed at each corner of the brewer.

Set brewer in its operating location. Level the brewer. A spirit level should be placed on the top of the unit, at the edge, as a guide when making level adjustments.

Level the unit from left to right and front to back by turning the adjustable feet. Be sure all four feet touch the counter to prevent tipping.

PLUMBER'S INSTALLATION INSTRUCTIONS

Brewer should be connected to a **POTABLE WATER, COLD WATER** line. Flush water line before connecting to brewer.

DO NOT use a saddle valve with a self-piercing tap for the water line connection. Such a tap can become restricted by waterline debris. For systems that must use a saddle tap, shut off the main water supply and drill a 3/16" (minimum) tap for the saddle connection, in order to insure an ample water supply. Remember to flush the line prior to installing the saddle.

The brewer must be installed on a water line with average pressure between 20 PSI and 90 PSI. If your water pressure exceeds 90 PSI at anytime, a pressure regulator must be installed in the water supply line to limit the pressure to not more than 90 PSI in order to avoid damage to lines and solenoid.

A water shut-off valve should be installed on the incoming water line in a convenient location (Use a low restriction type valve, such as a 1/4-turn ball valve, to avoid loss of water flow thru the valve).

NSF requires that the brewer be able to be moved for cleaning underneath. A flex line or loops of copper tubing will satisfy this requirement. See Figure 2 below.

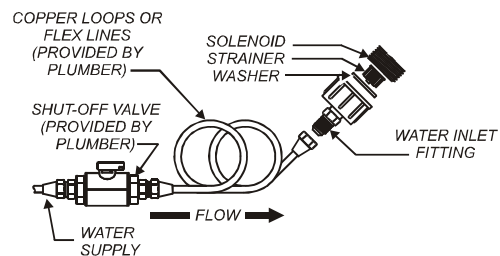

Fig. 2 Water Supply Installation

INSTALLATION INSTRUCTIONS (continued)

In some areas, local codes require a backflow preventer (check valve) to be installed on the inlet water line. If a backflow preventer is used, you must install a **water hammer arrester** in the incoming line, between the backflow preventer and the brewer inlet, as far away from the brewer as space will allow. This will relieve the excessive back pressures that can cause faucet leaks and solenoid malfunctions.

ELECTRICIAN'S INSTALLATION INSTRUCTIONS

REFER TO ELECTRICAL SPECIFICATIONS - Page 1
Check the nameplate to determine correct electrical service required for the brewer to be installed.

IMPORTANT: Before connecting to electricity, make sure automatic brewers are connected to the water supply.

Models 9010 & 9012 are equipped with a cord and plug. They require a 115 - 125 volt 20 amp circuit (50/60 Hz, 2 wire plus ground, with NEMA 5-15R or 5-20R Receptacle).

IMPORTANT: The ground prong of the plug is part of a system designed to protect you from electrical shock in the event of internal damage. Never cut off the ground prong nor twist a blade to fit an existing receptacle. Contact a licensed electrician to install the proper circuit and receptacle.

Models 9016 must be wired by an electrician, and require a 115/230V 20A circuit (50/60 Hz, 2 hot legs / 1 neutral leg, plus ground). Remove front panel to gain access to terminal block. Green terminal must be connected to a suitable building ground. Circuit must be capable of 3800 Watts. See figure 3 at right.

IMPORTANT: Wiring must be installed in approved solid or flexible conduit, and must be secured to the brewer with a strain relief (to be provided by the installer).

Models 9016EX must be wired by an electrician, and require a 220-240V 20A circuit (50/60 Hz, 2 hot legs plus ground). Remove front panel to gain access to terminal block. Green terminal must be connected to a suitable building ground. Circuit must be capable of 3800 Watts. Refer to 9016EX wiring diagram on page 23.

IMPORTANT: Wiring must be installed in accordance with local codes and ordinances.

NOTE: This equipment must be installed to comply with applicable federal, state and local plumbing codes and ordinances.

WARNING:
SHOCK HAZARD

Brewer must be properly grounded to prevent possible shock hazard. **DO NOT** assume a plumbing line will provide such a ground. Electrical shock will cause death or serious injury.

IMPORTANT: Do not connect brewer to electrical power until the tank is filled with water. Pour water into the pour-over opening until water flows from the brew head.

IMPORTANT: Supply power must match nameplate for voltage and phase. Connecting to the wrong voltage will damage the brewer or result in decreased performance. Such damage is not covered by warranty.

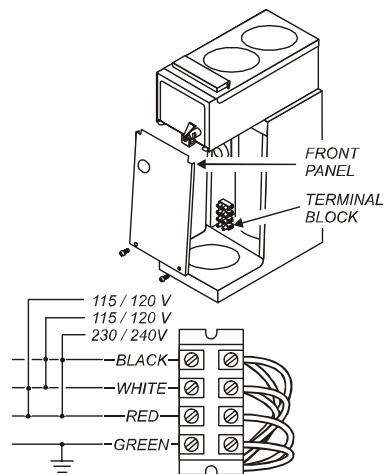

Fig. 3 115/240 Volt Terminal Block

OPERATION

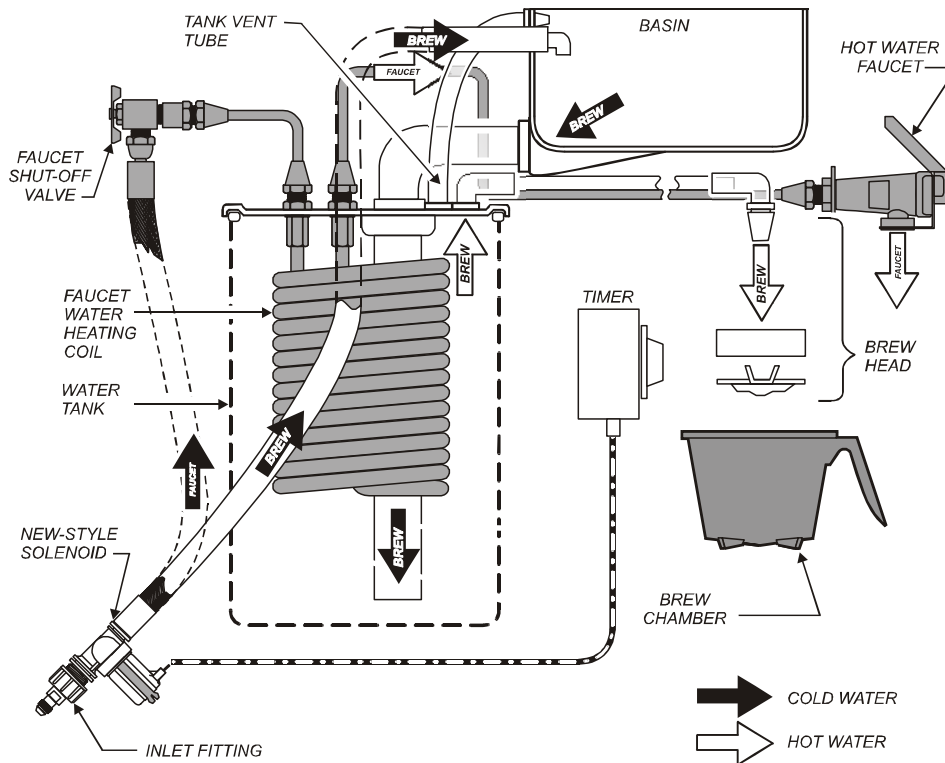
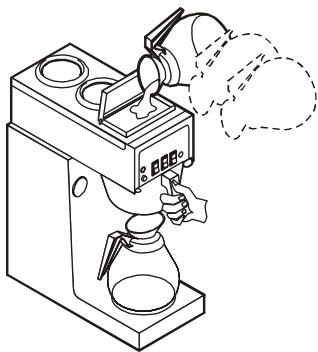

Fig. 4 Brewer Operation Diagram

IMPORTANT:

Tank must be full of water before connecting brewer to electrical power. Heating elements will be damaged if allowed to operate without being fully submerged in water. Damage caused by operating the brewer without water in the tank is **NOT COVERED BY WARRANTY**.



A. START-UP

For initial start-up, or if the brewer has not been used for an extended period of time:

- ◆ Be sure spray disk and brew gasket are properly installed in the brew head.
- ◆ Be sure the water supply is properly connected and the water supply valve is turned **ON**.
- ◆ Be sure the **WATER TANK IS FILLED**

BEFORE plugging the brewer into a receptacle, or otherwise connecting brewer to electrical power **THE WATER TANK MUST BE FILLED**. Place an empty decanter under the brew head. Lift the pour-over cover then pour warm tap water into the pour-over opening until water flows from the brew head. When water stops dripping from the brew head, empty the container.

Once the tank is full of water, connect the brewer to electrical power. The heating elements will begin heating the water in the tank. When the water has reached the proper temperature, the "HEAT" light will go out.

WATER HEATER

Water temperature is sensed by a thermobulb inserted into the water tank. This temperature signal is fed to the thermostat, which controls line power to the heating element.

The setpoint temperature is adjustable at the thermostat.

The element is protected from over-temperature by a hi-limit thermostat.

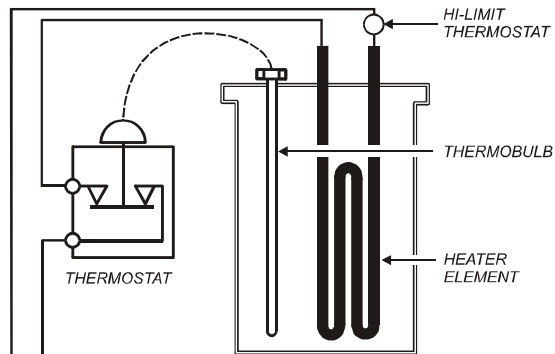
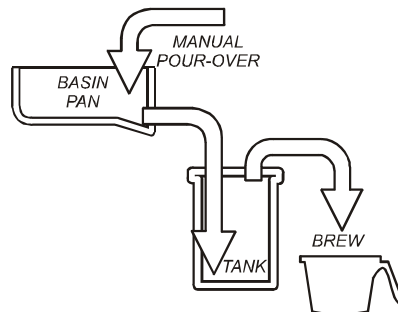

Fig. 5 Heat Control Diagram

WATER FLOW

POUR-OVER FEATURE

Pouring any amount of cold water into the pour-over opening and into the basin pan forces an identical amount of hot water out of the tank and through the spray head into the brew chamber.



AUTOMATIC OPERATION

Pressing BREW button energizes the solenoid valve, allowing water from an external water supply to flow into the basin pan and then into the hot water tank. This forces an identical amount of hot water out of the tank and through the spray head into the brew chamber.

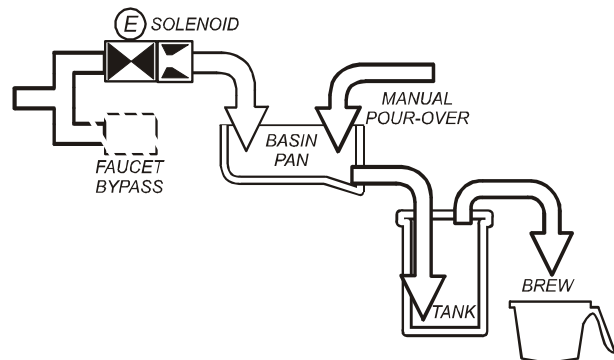

The solenoid uses a flow control device so that flow is consistent between 20 p.s.i. and 90 p.s.i.

Length of time the solenoid is open is controlled by the timer.

HOT WATER FAUCET

The faucet water coil is submerged in the hot water tank and draws heat from the brew water. Water going to the water coil is not controlled by the solenoid valve.

The faucet is at supply water pressure any time the faucet shut-off valve is OPEN.

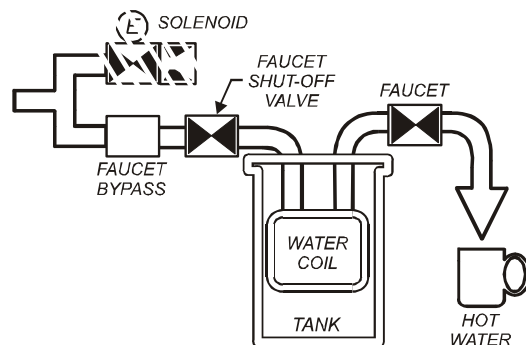

Fig. 6 Water Flow Diagram

BREWING COFFEE



CAUTION: BURN HAZARD

Exposed surfaces of the brewer, brew chamber and decanter may be HOT to the touch, and can cause serious burns.



CAUTION: BURN HAZARD

To avoid splashing or overflowing hot liquids, ALWAYS place an empty decanter under the brew chamber before starting the brew cycle. Failure to comply can cause serious burns.



CAUTION: BURN HAZARD

After a brew cycle, brew chamber contents are HOT. Remove the brew chamber and dispose of used grounds with care. Failure to comply can cause serious burns.

NOTE: Water for the hot water faucet is heated in a coil inside of the water tank. Use of the faucet will not affect the volume of water delivered for a brew. However, overuse of the faucet during a brew may lower the temperature of the brew water.

B. PREPARATION

Place one (1) genuine Bloomfield paper filter in the brew chamber.

Add a pre-measured amount of fresh coffee grounds.

Gently shake the brew chamber to level the bed of grounds. Slide the brew chamber into place under the brew head.

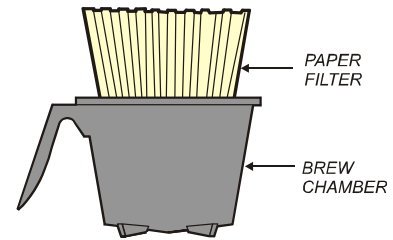

Fig. 7 Brew Chamber

C. POUR-OVER OPERATION

NOTE: Any Integrity™ brewer can be used in the pour-over mode.

BE sure "READY TO BREW" light is lit.

Place the appropriate *EMPTY* decanter in place under the brew chamber.

Fill a decanter with tap water. Lift the pour-over cover and pour the entire contents of the decanter into the pour-over opening, which will fill the basin.

Water from the basin will displace a like amount of heated water from the tank. The hot water will be forced into the brew head where it will spray over the bed of grounds. Freshly brewed coffee will begin to fill the container under the brew chamber. When the flow and all dripping stops, the coffee is ready to serve.

Discard the contents of the brew chamber. Rinse the brew chamber in a sink. When the "HEAT" light goes out, the brewer is ready for another brew cycle.

C. AUTOMATIC OPERATION

BE sure "READY TO BREW" light is lit.

Place an *EMPTY* decanter in place under the brew chamber.

Press the "BREW" switch. The solenoid will open for an amount of time determined by the timer setting, admitting a measured quantity of water into the basin.

Water from the basin will displace a like amount of heated water from the tank. The hot water will be forced into the brew head where it will spray over the bed of grounds. Freshly brewed coffee will begin to fill the decanter under the brew chamber. At the end of the brew cycle, plus an amount of time set to allow all water to drip out of the brew chamber, two beeps will sound. When the flow and all dripping stops, the coffee is ready to serve.

Discard the contents of the brew chamber and rinse it in a sink. When the "READY TO BREW" light comes on, the brewer is ready for another brew cycle.

CLEANING INSTRUCTIONS

PROCEDURE: Clean Coffee Brewer

PRECAUTIONS: Disconnect brewer from electric power.
Allow brewer to cool.

FREQUENCY: Daily

TOOLS: Mild Detergent, Clean Soft Cloth or Sponge
Bristle Brush.

1. Disconnect brewer from electric power.
Allow brewer to cool before cleaning.
2. Remove and empty decanters.
3. Remove and empty brew chamber.
4. Remove the spray disk from the brew head (See figure 8):
Press up on the spray disk ears, then turn the disk to the left to unlatch. Remove the gasket from inside the brew head.
5. Wipe inside of brew head and area around the brew head with a soft clean cloth or sponge moistened with clean water.
6. Wash the spray disk in a sink using warm water and a mild detergent. A bristle brush may be used to clear clogged spray holes. Rinse the spray disk with clean water and allow to air dry.
7. Wash the brew chamber in a sink using warm water and a mild detergent. A bristle brush may be used to clean the inside. Rinse with clean water and allow to air dry. For stainless steel brew chambers, be sure the wire rack is properly reinstalled.
8. Wipe the exterior of the brewer with a soft clean cloth or sponge moistened with clean water.
10. Reinstall the gasket *INSIDE* the brew head, then reinstall the spray disk.
11. Reinstall the brew chamber.
12. Decanters may be washed in a dishwasher or sink.

Procedure is complete



CAUTION: BURN HAZARD

Brewing and serving temperatures of coffee are extremely hot. Hot coffee will cause serious skin burns.



CAUTION: SHOCK HAZARD

Do not submerge or immerse brewer in water.

IMPORTANT:

DO NOT use steel wool, sharp objects, or caustic, abrasive or chlorinated cleansers to clean the brewer.

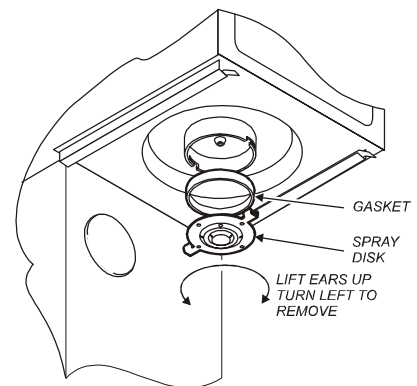

Fig. 8 Cleaning

TROUBLESHOOTING SUGGESTIONS

SYMPTOM	POSSIBLE CAUSE	SUGGESTED REMEDY
Water won't heat	Brewer unplugged or circuit breaker tripped	Check power supply cord Check / reset circuit breaker
	Thermostat set too low	Set for desired temperature
	Hi-Limit thermostat tripped	Allow to cool Reset hi-limit (8786, 8788)
	Damaged internal component or wiring	Examine wiring & connectors, thermostat and heating element Repair/replace as needed
Trips hi-limit safety at start-up	No water or too little water added at start-up	Be sure to add sufficient water prior to energizing
Coffee level low (pour-over)	Not enough water poured in	Increase water amount
	Too much coffee grounds	Adjust amount of grounds
Coffee level too high or low (automatic)	Timer out of adjustment	Adjust timer
Brew chamber overflows	Too many filter papers or wrong filter paper	Use one (1) genuine Bloomfield filter per brew
	Brew chamber dispense hole plugged	Thoroughly clean brew chamber
	Too much coffee or too fine a grind	Adjust coffee amount and grind
Sprays water from brew head incorrectly	Spray gasket missing or improperly installed	Check/reinstall gasket on INSIDE of brew head
	Spray disk plugged	Clean spray disk
No brew (automatic)	Water supply OFF	Turn water supply ON
	Water line strainer plugged	Clean strainer
	Water filter (if used) plugged	Replace filter element
	Bad BREW switch	Replace switch
	Damaged internal component or wiring	Examine wiring & connectors, brew switch and solenoid Repair/replace as needed
No flow from hot water faucet	Faucet valve turned OFF	Turn faucet valve ON
	Faucet plugged	Disassemble faucet, clean
Poor coffee quality	Water not hot enough	Adjust water temp 195-205°F
	<p>Also: Keep brewer, airpots and servers clean. Install a taste and odor filter in water supply, and replace cartridges regularly. Use a quality coffee with a consistent roast. Use proper grind and amount of coffee per brew.</p>	

ACCESS PANELS

Each warmer plate has a center stud which screws into a bracket. Warmer plates on Canadian brewers are secured with a nut. Remove button plug on bottom of brewer to access nut on main warmer. Remove top panel to access nuts on top warmers. Remove warmer plates by turning counter-clockwise.

Solenoid door is held by two screws and a retaining lip.

IN-LINE BREWERS:

Top panel is held by two screws at the rear and a retaining lip at the front. Disconnect wires from the upper warmers.

Top front panel is held by two screws at the bottom and a retaining lip at the top.

Bottom front panel is held by two clips under the warmer plate.



**CAUTION:
SHOCK HAZARD**

Opening access panels or removing warmer plates on this brew may expose uninsulated electrical components. Disconnect brewer from electrical power before removing any panel or warmer plate.

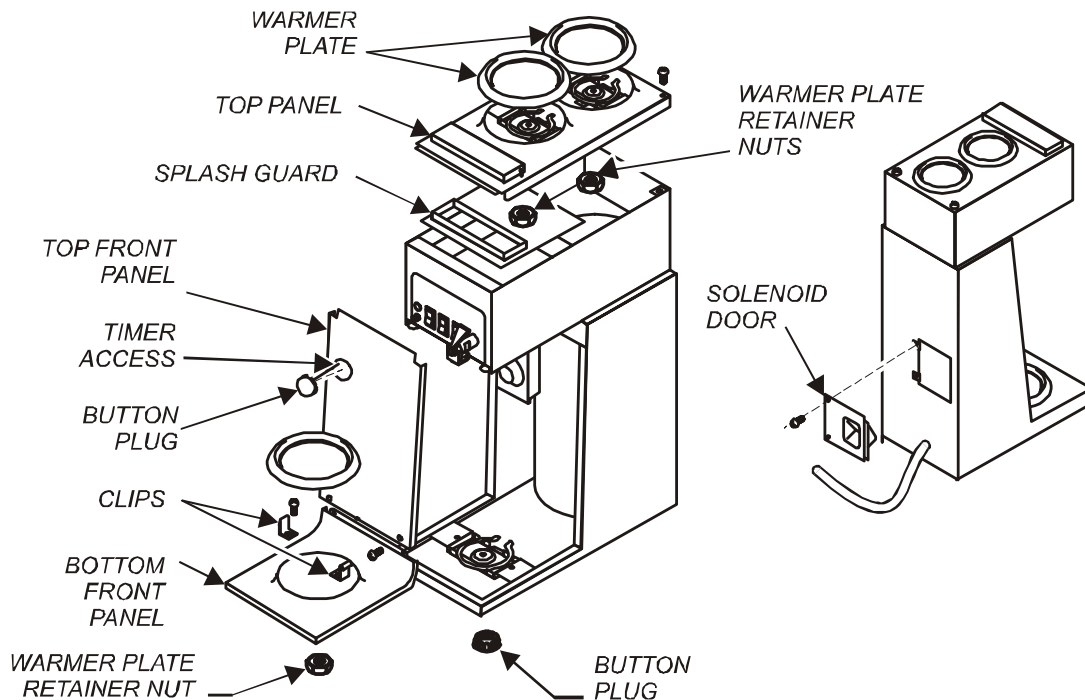

Fig. 9 Access Panels

601 75815 Owners Manual Integrity Decanter Brewers

SERVICING INSTRUCTIONS (continued)



CAUTION: SHOCK HAZARD

These procedures involve exposed electrical circuits. These procedures are to be performed by qualified technical personnel only.

NOTE:

Optimum brewing temperature range is 195°F to 205°F (90°C to 96°C).

IMPORTANT:

A mechanical thermostat will maintain temperature within $\pm 5^\circ\text{F}$. To prevent boiling water in the brewer, thermostat should be adjusted to a maximum temperature equal to the local boiling temperature minus 5°F.

NOTE: 1/8 turn = approximately 10°F (5.6°C).

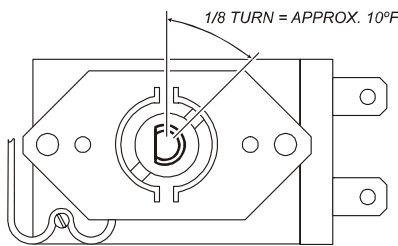

Fig. 11 Adjust Thermostat

TEMPERATURE ADJUSTMENT

Unplug power cord or turn circuit breaker OFF. Remove top panel.

Pull vent tube out of tank lid and insert a thermometer of known accuracy in vent hole. Reconnect brewer to electrical power.

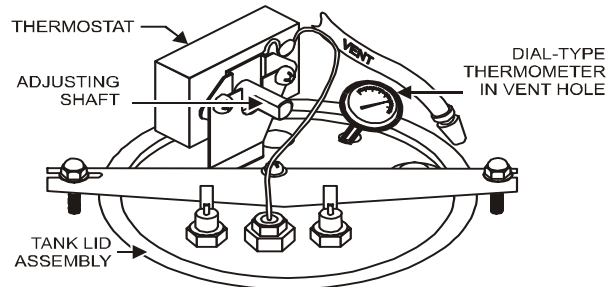

Fig. 10 Checking and Adjusting Brew Temperature

Place an empty decanter under brew chamber. Energize brewer and pour one decanter (64 oz.) of cold water into pour-over opening. When READY TO BREW light comes on, read temperature displayed on thermometer.

Adjust thermostat by turning shaft; clockwise increases temperature. 1/8 turn = approximately 10°F.

Refer to Table 1 below for proper brewing temperature based on altitude.

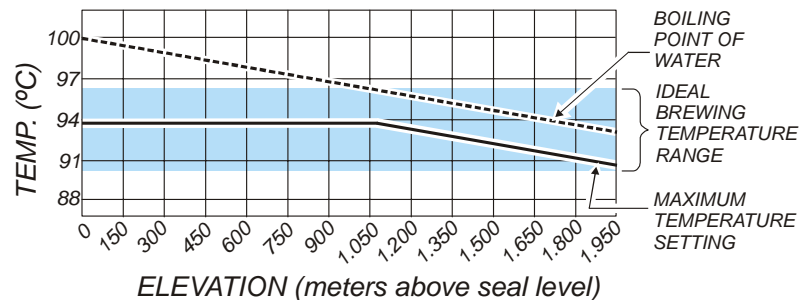
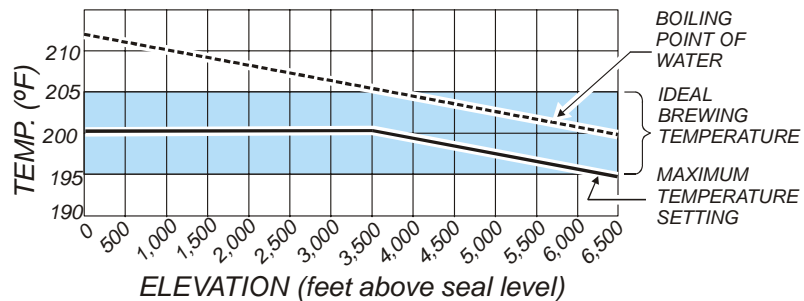

Table 1 Boiling Temperature by Altitude

Upon completion, remove thermometer and reinstall vent tube.

TIMER ADJUSTMENT

The amount of water dispensed automatically during a brew cycle is controlled by the timer.

Place empty decanter under brew chamber. Press BREW button. Brewer should dispense one decanter of water. To adjust amount:

Remove brew chamber and button plug. Adjust knob on timer; clockwise increases time. Run several cycles to check amount of water delivered. Replace button plug.

REMOVE TANK LID ASSEMBLY

Unplug brewer or turn circuit breaker *OFF*. Turn *OFF* water supply. Remove top panel. Pull vent tube and inlet elbow out of basin pan.

Pull water inlet tube out of basin pan. Remove basin pan.

On models with faucet, disconnect inlet pipe at faucet shut-off valve and outlet pipe at faucet.

Disconnect all wiring from thermostat, hi-limit, and heating element.

Loosen center screw on tank hold-down bracket. Remove hold-down bracket by sliding short slotted end off of locking stud and lifting it off. Remove cover assembly by lifting it straight up.

Reassemble in reverse order.

REPLACE THERMOSTAT

Unplug brewer or turn circuit breaker *OFF*. Turn *OFF* water supply. Remove top panel.

Disconnect all wiring from thermostat only. Loosen and free jam nut from pass-thru fitting securing temperature sensing bulb. Remove two screws holding thermostat to bracket.

Lift out thermostat, sensing bulb and thermostat gasket.

Push sensing bulb into tank lid thermowell until fitting seats. Tighten capillary lock nut only enough to ensure no water leakage. Excessive tightening is not necessary.

Reassemble in reverse order.

IMPORTANT: Water pressure must be between 20 p.s.i and 90 p.s.i. flowing pressure. If water pressure exceeds this value, or if water pressure varies greatly, a pressure regulator must be installed in the water supply line.

IMPORTANT: Before setting assembly into tank, make sure tank lid gasket is properly seated on flange of lid. *DO NOT OVER-TIGHTEN.*

IMPORTANT: If mounting thermostat p/n 8512-51, be sure to place a new seal washer below the fitting on the capillary line.

If replacing gray-bodied thermo with p/n 8512-51, be sure to remove tube from thermowell.

SERVICING INSTRUCTIONS (continued)

IMPORTANT: When replacing heating element, also replace seal gaskets.

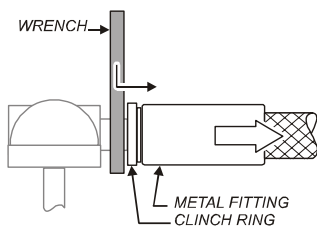
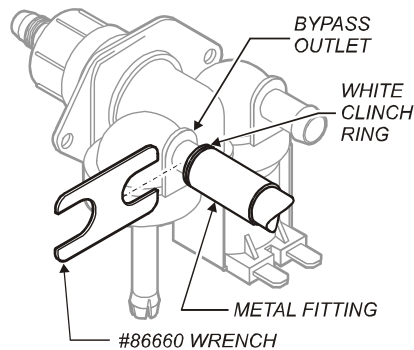

SLIDE WRENCH BETWEEN VALVE AND HOSE FITTING
PRESS CLINCH RING TOWARD METAL FITTING TO RELEASE

Fig. 11 Remove Faucet Supply from Solenoid

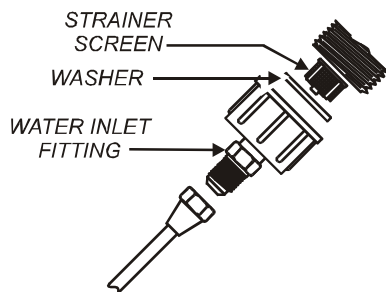

Fig. 12 Clean Strainer Screen

REPLACE HEATING ELEMENT

Remove tank lid assembly as described on page 13.

Remove two hex nuts holding element to cover. Pull element from mounting holes.

Reassemble in reverse order.

REPLACE SOLENOID

Symptom: Automatic brewer will not flow water; or, automatic brewer drips continuously from brew head.

NOTE: Wrench p/n 86660 is designed to allow easy removal of the hoses from the plastic solenoid valve.

IMPORTANT: Shut-off water and electric supply to brewer before removing hoses or wiring.

Remove water supply flare fitting:

- Slide the 5/8" end of the wrench over the flats on the inlet fitting of the valve.
- Hold the wrench to prevent the inlet fitting from turning while installing or removing the inlet water supply flare nut.

Remove braided hose:

- Slide the 7/16" end of the wrench between the valve body and the white ring on the extreme end of the metal hose fitting.
- Pressure on the white ring toward the metal ferrule releases the clinch ring, allowing the hose to be easily slid off of the solenoid bypass outlet.
- Install hose on new valve by pressing end of hose onto bypass outlet until it is fully seated.

Disconnect wiring.

Remove two screws holding solenoid to access door.

Reassemble in reverse order.

CLEAN SOLENOID SCREEN

Symptom: Automatic brewer will not flow water.

Unplug power cord or turn circuit breaker *OFF*. Turn *OFF* and disconnect water supply from brewer inlet fitting.

Unscrew water inlet fitting from solenoid.

Using needle-nose pliers, withdraw strainer screen from solenoid. Clean screen under faucet. A stiff bristle brush may be used if necessary.

Reinsert screen in solenoid. Be careful to maintain correct orientation. (The *OPEN END* of the screen goes in *FIRST*.)

Reassemble in reverse order.

REPLACE TIMER ASSEMBLY

Unplug power cord or turn circuit breaker OFF.

Remove front panel. Remove knob and three screws holding timer to bracket. Disconnect wiring to timer.

Reassemble in reverse order.

Adjust timer as described on page 13

REPLACE HOT WATER FAUCET COIL

Symptom: Brewer drips continuously from brew head, except when faucet valve is turned OFF.

Remove tank lid assembly per above.

Remove two hex nuts hot water coil to cover. Pull coil from mounting holes.

Reassemble in reverse order.

REPAIR HOT WATER FAUCET

Remove top panel and turn faucet valve OFF.

Unscrew aerator cap from faucet and remove handle retaining clip. Do not let faucet body turn.

Pull bonnet assembly from faucet body.

Examine the interior of the faucet body and the surface of the seat cup. Clean out any debris in the faucet body, using a stiff bristle brush if necessary.

Examine the aerator. Clean any debris from the screen or flow straightener, using a stiff bristle brush if necessary.

Reassemble in reverse order.

REPLACE BREW READY LIGHT or BREW BUTTON

Unplug power cord or turn circuit breaker OFF.

Using Switch Removal Tool (p/n 83209) or a thin screwdriver, pry light or switch from mounting hole. Disconnect leads.

Reassemble in reverse order.

IMPORTANT: When replacing water faucet coil, also replace seal gaskets.

NOTE: Any abrasion or roughness on the flat end of the seat cup will require replacing the seat cup:

Work the seat cup out of the bonnet and off of the end of the stem.

Install a new seat cup, making sure the knob on the stem is fully inserted into the pocket of the seat cup, and the skirt of the seat cup is fully inserted into the bonnet.

SERVICING INSTRUCTIONS (continued)



CAUTION: CHEMICAL BURN HAZARD

Deliming chemicals may be caustic. Wear appropriate protective gloves and goggles during this procedure. Never siphon deliming chemicals or solutions by mouth. This operation should only be performed by qualified and experienced service personnel.

IMPORTANT: DO NOT spill, splash or pour water or deliming solution into or over any internal component other than the inside of the water tank.

IMPORTANT: DO NOT allow any internal components to come into contact with the deliming solution. Take care to keep all internal components dry.

NOTE: Repeat steps 4 thru 5 as required to remove all scale and lime build-up.

PROCEDURE: Delime the Water Tank

PRECAUTIONS: Disconnect brewer from electric power. Allow brewer to cool.

FREQUENCY: As required (Brewer slow to heat)

TOOLS: Deliming Solution
Protective Gloves, Goggles & Apron
Mild Detergent, Clean Soft Cloth or Sponge
Bristle Brush, Bottle Brush
Large Sink (or other appropriate work area)

1. Disconnect brewer from the electrical supply. Turn off the water shut-off valve and disconnect the water supply line from the brewer inlet fitting.
2. Remove the tank lid assembly as described on page 13.
3. Remove the water tank from the brewer body by lifting straight up. Empty all water from the tank. Set the tank back into the brewer.
4. Mix 2 quarts of deliming solution according to the manufacturer's directions. Carefully pour the deliming solution into the water tank. Lower the lid assembly back onto the tank. Allow to sit for 30 minutes, or as directed by the manufacturer.
5. At end of soaking period, remove lid assembly from tank. Thoroughly rinse internal components of lid assembly with clear water. Using a stiff bristle brush, scrub the heating element (and faucet water coil on automatic brewers) to remove lime and calcium build-up. Rinse with clean water. Store lid assembly in a safe location .
6. Remove the tank from the brewer and empty. Using a stiff bristle brush, scrub the interior of the water tank to remove lime and calcium build-up. Rinse with clean water.

SERVICING INSTRUCTIONS (continued)

7. Set the tank back into the brewer. Reassemble the tank lid to the water tank. Make sure the gasket is properly in place, then reinstall the hold-down strap.
8. Reinstall wiring to heating element and thermostat. Reinstall the hi-limit thermostat (if removed). For brewers with hot water faucet, reassemble faucet piping. Verify that all internal components are dry, then reinstall the top panel.
10. Reconnect brewer to electrical supply and, for automatic brewers, reconnect water supply.
11. Install the brew chamber without filter paper or grounds. Run at least three full brew cycles and discard all water generated.
12. Brewer is ready to use.

NOTE: Normally, silicone hoses do not need to be delimed. Should deliming hoses become necessary, Bloomfield recommends replacing the hoses.

EXPLODED VIEW & PARTS LIST

HOT WATER TANK ASSEMBLY

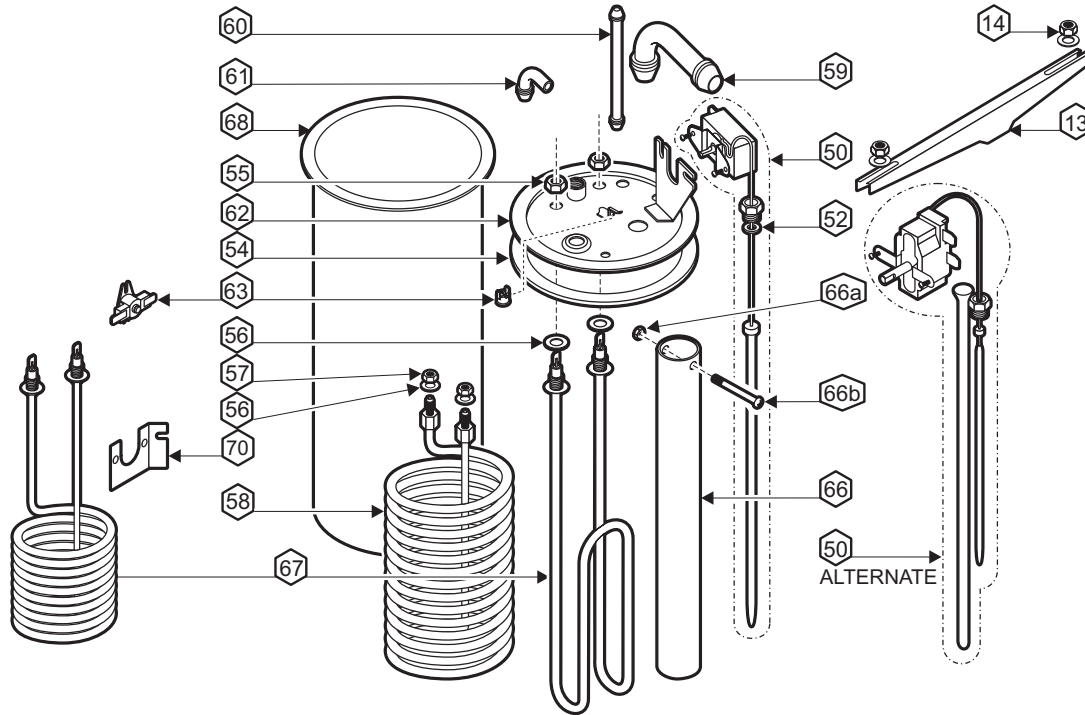

ITEM	PART NO.	DESCRIPTION	USED ON
13	8043-5	HOLD-DOWN STRAP	9010, 9012(CA), 9016(EX)
14	83457	NUT, HEX 8-32 KEPS	9010, 9012(CA), 9016(EX)
50	8512-51 86280	THERMOSTAT (BLACK BODY - INCL. SEAL & MOUNTING SCREWS) THERMO (ALT) (GRAY BODY - INCL. TUBE & MOUNTING SCREWS)	9010, 9012(CA), 9016(EX)
52	8512-41	SEAL WASHER, THERMO CAP TUBE (ONLY)	9010, 9012(CA), 9016(EX)
54	8043-12	TANK COVER GASKET	9010, 9012(CA), 9016(EX)
55	8043-28	NUT HEX 1/2-20 BRASS	9010, 9012(CA), 9016(EX)
56	8043-30	SEAL GASKET, ELEMENT OR WATER COIL	9010, 9012(CA), 9016(EX)
57	8941-21	NUT HEX 7/16-20 BRASS	
58	8540-6	HOT WATER COIL	9010, 9012(CA), 9016(EX)
59	8043-8	TUBE, BASIN OUTLET/TANK INLET, SILICONE	9010, 9012(CA), 9016(EX)
60	8043-15	TUBE, VENT, SILICONE	9010, 9012(CA), 9016(EX)
61	8043-11	ELBOW, TANK OUTLET, SILICONE	9010, 9012(CA), 9016(EX)
62	8514-68	TAN COVER, PLATE ONLY, 8 HOLES	9010, 9012(CA), 9016(EX)
63	8043-83 8552-50	THERMOSTAT, HI-LIMIT THERMOSTAT, HI-LIMIT RESET	9012(CA) 9010, 9016(EX)
66	8043-24	WATER INLET TUBE	9010, 9012(CA), 9016(EX)
66a	8543-74	NUT, HEX 4-40 SS	9010, 9012(CA), 9016(EX)
66b	8543-73	SCREW 4-40 x 1 PAN HEAD	9010, 9012(CA), 9016(EX)
67	8043-93 8043-14 8716-1	HEATING ELEMENT (120V, 1200W) HEATING ELEMENT (120V, 1500W) HEATING ELEMENT (240V, 3500W)	9012CA 9010, 9012 9016, 9016EX
68	8043-10	TANK BODY	9010, 9012(CA), 9016(EX)
70	80625	BRACKET, HI LIMIT THERMOSTAT	9010, 9016 (EX)

TANK COVER ASSEMBLY

8541WF-300	INCLUDES: MOUNTED THERMO, HI-LIMIT, 120V 1500W HEATING ELEMENT & HOT WATER COIL)
------------	--

EXPLODED VIEW & PARTS LIST (continued)

CABINET PLUMBING COMPONENTS

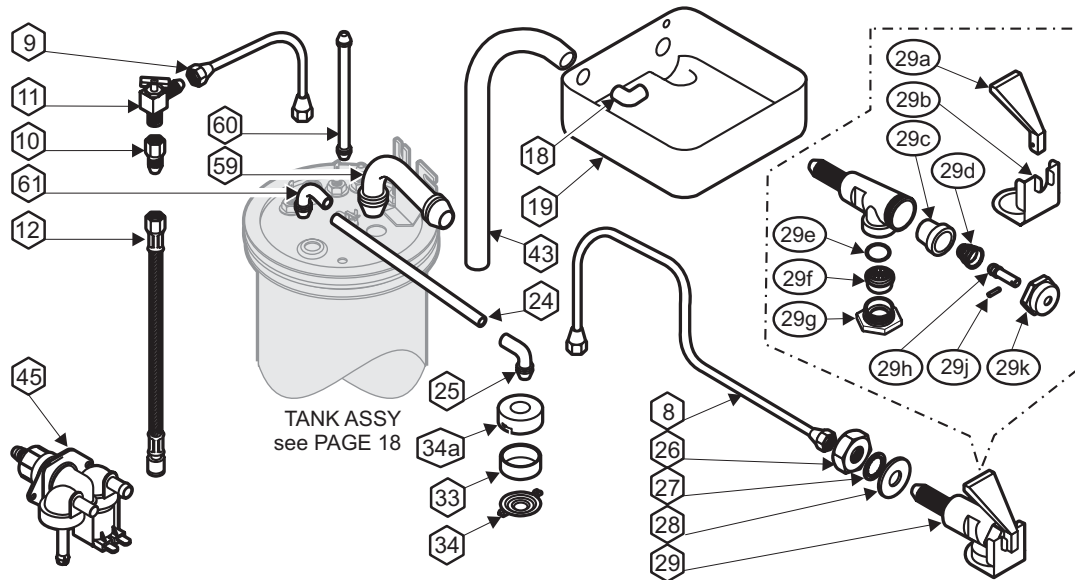

ITEM	PART NO.	DESCRIPTION	USED ON
8	8540-3	FORMED TUBE, FAUCET OUTLET ASSEMBLY 10-7/8" LONG	9010, 9012(CA), 9016(EX)
9	8540-4	FORMED TUBE, FAUCET COIL INLET ASSEMBLY	9010, 9012(CA), 9016(EX)
10	8551-30	ADAPTER, 1/4" MALE FLARE x 1/8" FPT BRASS	9010, 9012(CA), 9016(EX)
11	8514-26	VALVE, FAUCET SHUT OFF, NEEDLE SEAT	9010, 9012(CA), 9016(EX)
12	85681	BRAIDED TUBE, FAUCET INLET 6MM x 299MM (11-3/4") LONG	9010, 9012(CA), 9016(EX)
18	8540-30	ELBOW, BASIN INLET DIVERTER POLYPROPYLENE	9010, 9012(CA), 9016(EX)
24	8043-26	TUBE, BREW OUTLET, METAL 4-3/4" LONG	9010, 9012(CA), 9016(EX)
25	8043-13	ELBOW, SPRAYER, SILICONE	9010, 9012(CA), 9016(EX)
26	82680	LOCK NUT, HEX 7-16-20	9010, 9012(CA), 9016(EX)
27	8551-100B	LOCK WASHER 7/16" EXT SEMS (FAUCET)	9010, 9012(CA), 9016(EX)
28	82681	WASHER, FLAT 15/32" x 1-1/8" x 1/16" SS	9010, 9012(CA), 9016(EX)
29	82556	FAUCET ASSEMBLY, PRESSURE	9010, 9012(CA), 9016(EX)
33	8543-42	GASKET, SPRAY HEAD	9010, 9012(CA), 9016(EX)
34	82727	SPRAY DISK, EMBOSSED	9010, 9012(CA), 9016(EX)
34a	8543-45	RETAINER, SPRAY HEAD (REQUIRES DRILL/RIVETS TO INSTALL)	9010, 9012(CA), 9016(EX)
43	8541-46	TUBE, BASIN INLET, SILICONE 13"	9010, 9012(CA), 9016(EX)
45	85685 84570	SOLENOID W/BYPASS, 120V, .75 GPM SOLENOID W/BYPASS, 220/240V, .75 GPM	9010, 9012(CA) 9016(EX)
59	8043-8	TUBE, BASIN OUTLET/TANK INLET, SILICONE	9010, 9012(CA), 9016(EX)
60	8043-15	TUBE, VENT, SILICONE	9010, 9012(CA), 9016(EX)
61	8043-11	ELBOW, TANK OUTLET, SILICONE	9010, 9012(CA), 9016(EX)
108	8541-21	BASIN PAN	9010, 9012(CA), 9016(EX)

FAUCET REPAIR KITS

82573	HANDLE, FAUCET RED (29a)
82575	SEAT CUP (29c)
82576	FAUCET REPAIR KIT, INCL: HANDLE (29a), SEAT CUP (29c), SPRING (29d), STEM (29h), PIN (29j) & BONNET (29k)
82682	RETAINER CLIP (29b)
84804	AERATOR REPLACEMENT, INCL: O-RING (29e), DISK (29f) & CAP (29g)
84870	AERATOR REPAIR KIT, INCL: O-RING (29e) & DISK (29f)

EXPLODED VIEW & PARTS LIST (continued)

ELECTRICAL COMPONENTS

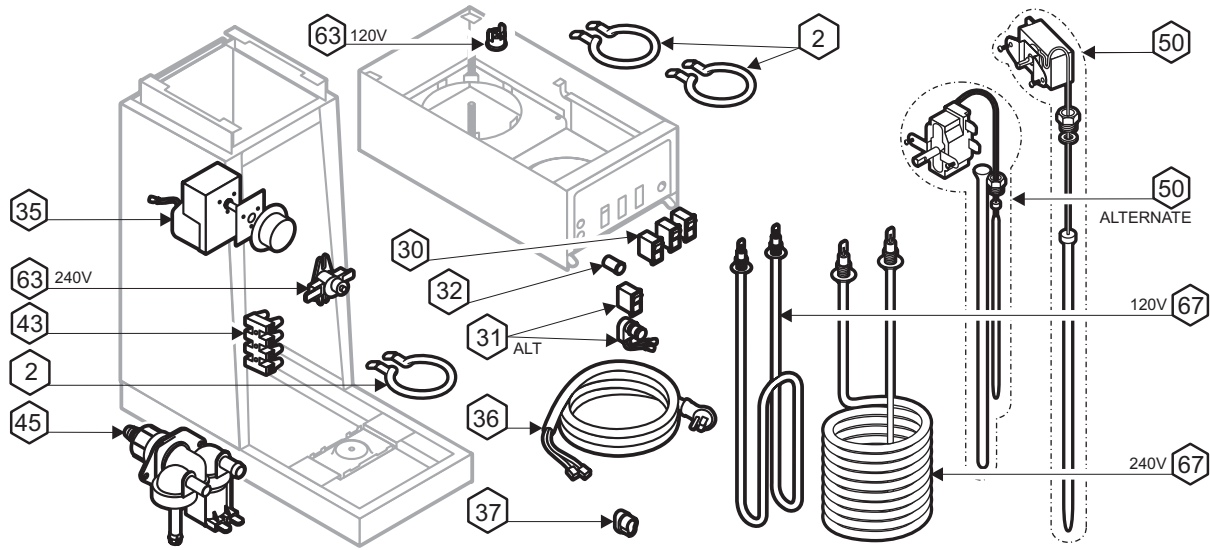

ITEM	PART NO.	DESCRIPTION	USED ON
2	8572-18 8533-32	HEATING ELEMENT, WARMER 120V 100W HEATING ELEMENT, WARMER 220V 85W / 240V 100W	ALL EXCEPT 9016(EX) 9016(EX)
30	6710-23 8563-110	SWITCH, WARMER ON/OFF 120V SWITCH, WARMER ON/OFF 240V	ALL EXCEPT 9016(EX) 9016(EX)
31	8572-24 8707-55	SWITCH, MOMENTARY PUSH-BUTTON, BREW SWITCH, MOMENTARY ROCKER, BREW	9010, 9012(CA), 9016(EX)
32	8718-31 8738-2	INDICATOR, 120V, READY-TO-BREW INDICATOR, 240V, READY-TO-BREW	ALL EXCEPT 9016(EX) 9016(EX)
35	8718-1 8738-1	TIMER, 2-MINUTE (WITH DIAL & KNOB) 120V TIMER, 2-MINUTE (WITH DIAL & KNOB) 240V	ALL EXCEPT 9016(EX) 9016(EX)
36	6407-15	POWER CORD ASSEMBLY, 120V NEMA 5-15P	9010, 9012(CA)
37	35-210	STRAIN RELIEF	9010, 9012(CA)
43	8552-18	TERMINAL BLOCK, 4P	9016(EX)
45	85685 84570	SOLENOID W/BYPASS, 120V, .75 GPM SOLENOID W/BYPASS, 220/240V, .75 GPM	9010, 9012(CA) 9016(EX)
50	8512-51 86280	THERMOSTAT (BLACK BODY - INCL. SEAL & MOUNTING SCREWS) THERMO (ALT) (GRAY BODY - INCL. TUBE & MOUNTING SCREWS)	9010, 9012(CA), 9016(EX)
63	8043-83 8552-50	THERMO, HI-LIMIT THERMO, HI-LIMIT, RESET	9012(CA) 9010, 9016(EX)
67	8541-1 8043-14 8716-1	HEATING ELEMENT, WATER TANK 120V 2000W HEATING ELEMENT, WATER TANK 120V 1500W HEATING ELEMENT, WATER TANK 240V 3500W	9010, 9012(CA) 9012CA 9016(EX)

SOLENOID REPAIR KITS

84570	SOLENOID 220/240V W/BYPASS .75GPM, COMPLETE
85685	SOLENOID 120V W/BYPASS .75GPM, COMPLETE
85218	INLET FITTING KIT INCLUDES: CAP (45a), FITTING (45b), GASKET (45c) & STRAINER (45d)
85219	INLET STRAINER (45d ONLY)

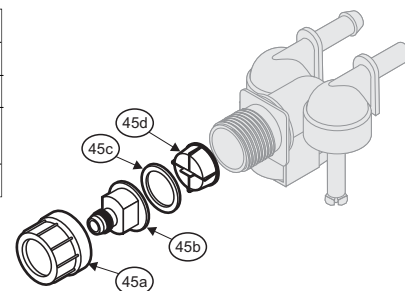

EXPLODED VIEW & PARTS LIST (continued)

CABINET COMPONENTS

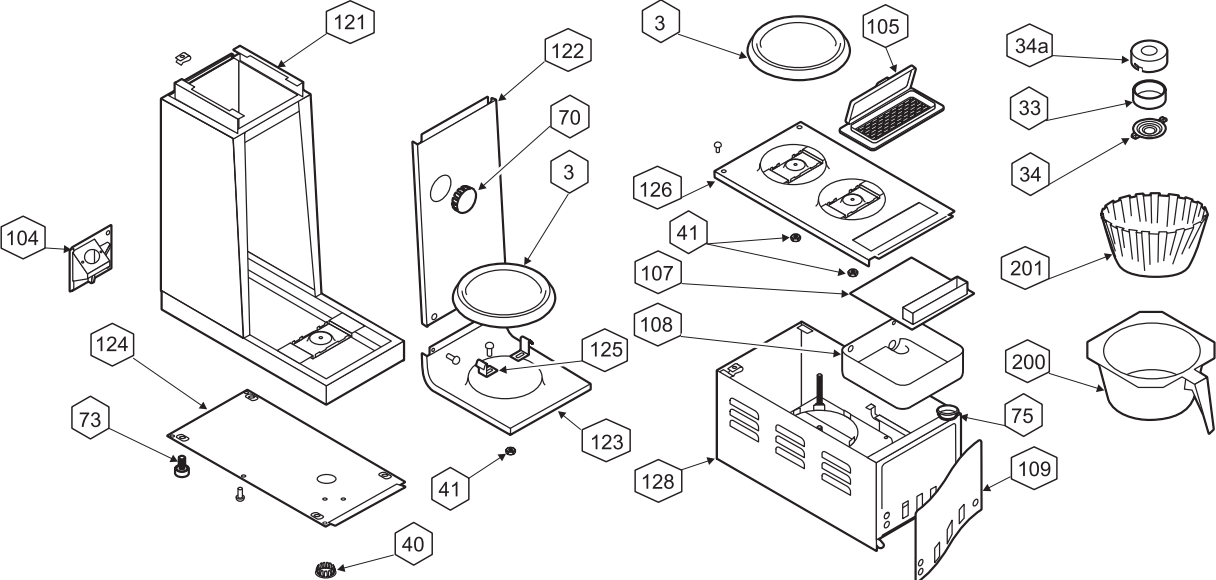

ITEM	PART NO.	DESCRIPTION	USED ON
3	8700-16	COVER PLATE, WARMER BLACK	9010, 9012(CA), 9016(EX)
33	8543-42	GASKET, SPRAY HEAD	9010, 9012(CA), 9016(EX)
34	82727	SPRAY DISK, EMBOSSED	9010, 9012(CA), 9016(EX)
34a	8543-45	RETAINER, SPRAY HEAD (REQUIRES DRILL/RIVETS TO INSTALL)	9010, 9012(CA), 9016(EX)
70	8706-75	BUTTON PLUG, 2", METAL	9010, 9012(CA), 9016(EX)
73	81732	LEG ASSEMBLY, LEVELLING	9010, 9012(CA), 9016(EX)
75	8543-69	BUSHING, HEYCO	9010, 9012(CA), 9016(EX)
104	85089	DOOR, SOLENOID ACCESS, PLASTIC	9010, 9012(CA), 9016(EX)
105	86666	POUR OVER ASSEMBLY, PLASTIC	9010, 9012(CA), 9016(EX)
107	9012-28	SPLASH GUARD, POUR-OVER	9010, 9012(CA), 9016(EX)
108	8541-21	BASIN PAN	9010, 9012(CA), 9016(EX)
121	9012-11 9016-211	BODY & BASE ASSEMBLY BODY & BASE ASSEMBLY, EXPORT	9010, 9012(CA), 9016 9016(EX)
122	9012-7	PANEL, UPPER FRONT	9010, 9012(CA), 9016(EX)
123	9012-6	PANEL, LOWER FRONT	9010, 9012(CA), 9016(EX)
124	9012-23	BOTTOM PLATE	9010, 9012(CA), 9016(EX)
125	8543-80	CLIP, MOUNTING	9010, 9012(CA), 9016(EX)
126	9012-10	BASIN COVER W/ 2 WARMER PLATE MOUNTS	9010, 9012(CA), 9016(EX)
200	8942-6B 8942-6 8707-6	BREW CHAMBER, BLACK PLASTIC BREW CHAMBER, BROWN PLASTIC (OPTIONAL limited to stock on hand) BREW CHAMBER, STAINLESS W/ WIRE BASKET (OPTIONAL)	9010, 9012(CA), 9016(EX)
201	POF	FILTER PAPER, COFFEE (CASE OF 1000)	9010, 9012(CA), 9016(EX)

601 75815 Owners Manual Integrity Decanter Brewers

WIRING DIAGRAMS

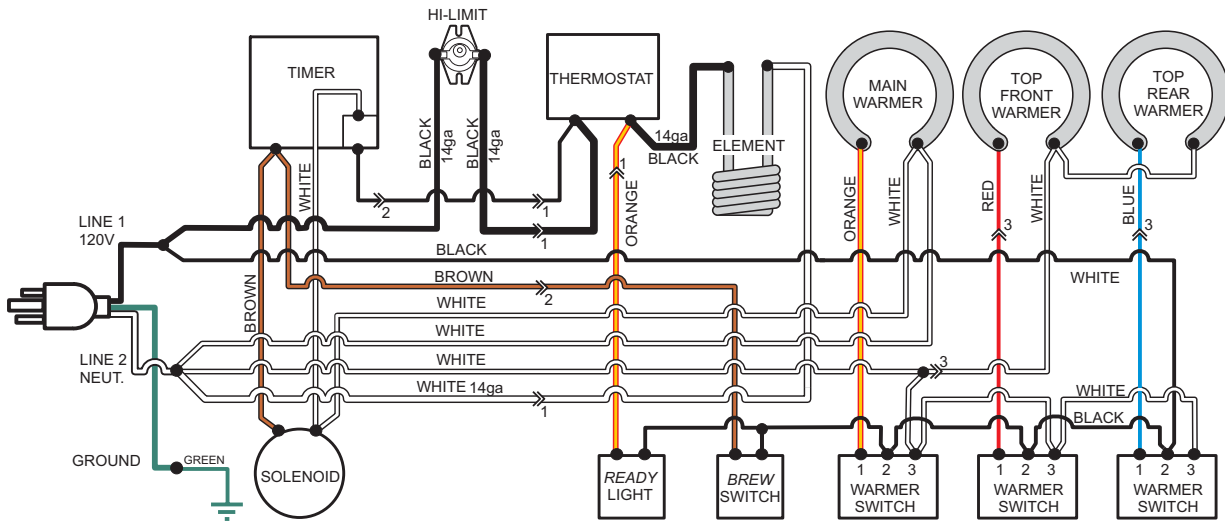

MODEL 9010
p/n 75446

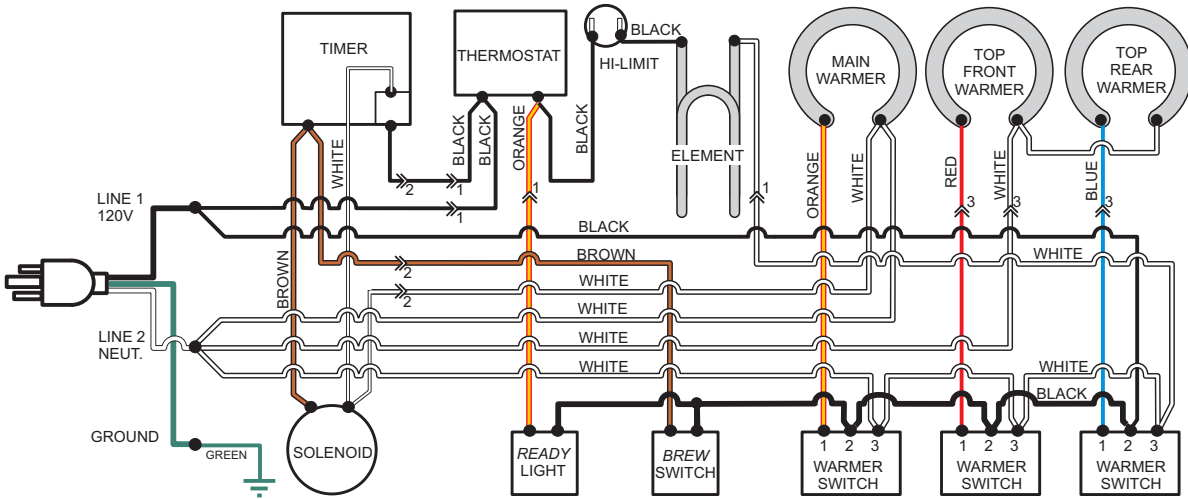

MODEL 9012
p/n 71725

601 75815 Owners Manual Integrity Decanter Brewers

WIRING DIAGRAMS (continued)

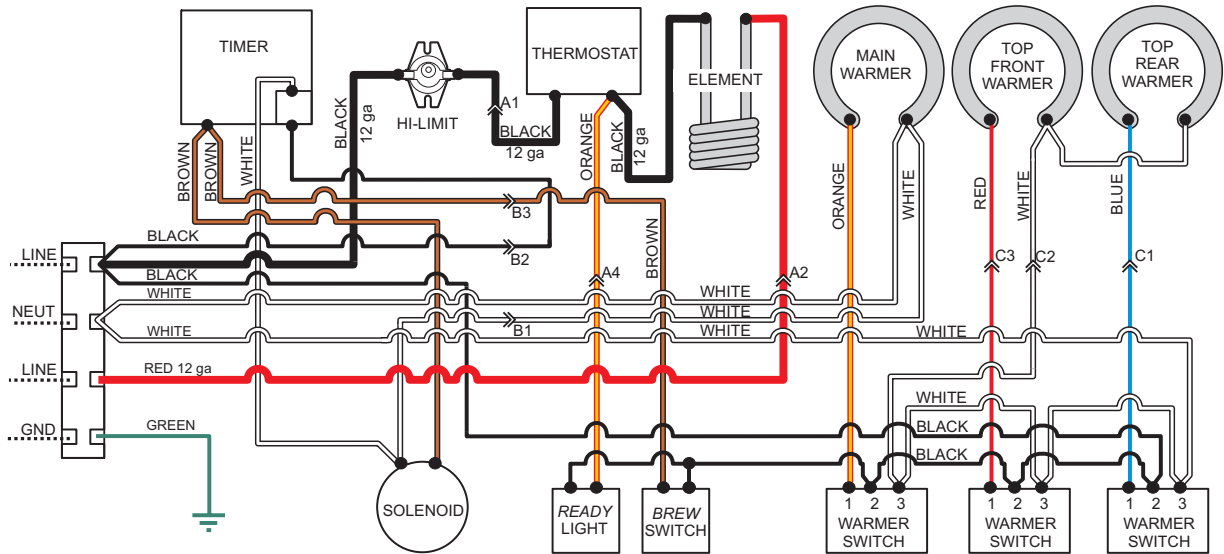

MODEL 9016
p/n 72356

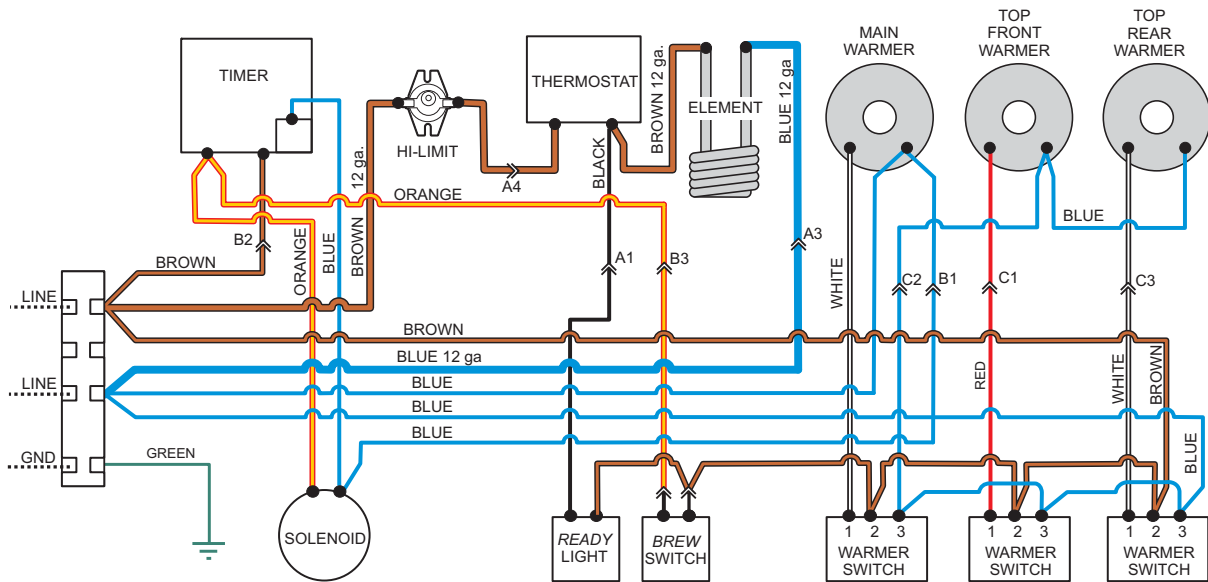

MODEL 9016EX
p/n 73652

601 75815 Owners Manual Integrity Decanter Brewers



Wells Bloomfield proudly supports CFESA
Commercial Food Equipment Service Association

SERVICE TRAINING - QUALITY SERVICE



CUSTOMER SATISFACTION

WELLS BLOOMFIELD

WELLS BLOOMFIELD, LLC

2 ERIK CIRCLE, P. O. Box 280 Verdi, NV 89439

telephone: 775-689-5707 fax: 775-689-5976

www.wellsbloomfield.com

PRINTED IN UNITED STATES OF AMERICA