

**BLOOMFIELD INDUSTRIES**

2 ERIK CIRCLE, P. O. Box 280  
Verdi, NV 89439  
telephone: 775-689-5700  
fax: 888-492-2783  
[www.wellsbloomfield.com](http://www.wellsbloomfield.com)



*Model 8752 Brewer  
with optional  
8900-Series Decanters*

**OWNERS MANUAL  
for**

**INTEGRITY™**

**5-WARMER  
COFFEE BREWERS**

**MODEL:  
8752  
8752KFT**

**Includes:**

**Installation  
Operation  
Use & Care  
Servicing Instructions**

PRINTED IN UNITED STATES OF AMERICA

## WARRANTY STATEMENT

All electrical equipment manufactured by BLOOMFIELD INDUSTRIES is warranted against defects in materials and workmanship for a period of one year from the date of original installation or eighteen (18) months from the date of shipment from our factory, whichever comes first, and is for the benefit of the original purchaser, except that:

- a. airpots carry a 30 day parts warranty only.
- b. dispensers; i.e., tea and coffee carry a 90 days parts warranty only, excludes decanters.

THE FOREGOING OBLIGATION IS EXPRESSLY GIVEN IN LIEU OF ANY OTHER WARRANTIES, EXPRESSED OR IMPLIED, INCLUDING ANY IMPLIED WARRANTY OF MERCHANTABILITY OR FITNESS FOR A PARTICULAR PURPOSE, WHICH ARE HEREBY EXCLUDED.

BLOOMFIELD INDUSTRIES DIVISION / SPECIALTY EQUIPMENT MANUFACTURING CORPORATION SHALL NOT BE LIABLE FOR INDIRECT, INCIDENTAL OR CONSEQUENTIAL DAMAGES OR LOSSES FROM ANY CAUSE WHATSOEVER.

This warranty is void if it is determined that upon inspection by an Authorized Service Agency that the equipment has been modified, misused, misapplied, improperly installed, or damaged in transit or by fire, flood or act of God.

It also does not apply if the serial nameplate has been removed or unauthorized service personnel perform service. The prices charged by Bloomfield Industries for its products are based upon the limitations in this warranty. Seller's obligation under this warranty is limited to the repair of defects without charge by a Bloomfield Industries Authorized Service Agency or one of its sub-agencies. This service will be provided on customer's premises for non-portable models. Portable models (a device with a cord and plug) must be taken or shipped to the closest Authorized Service Agency, transportation charges prepaid, for services.

In addition to restrictions contained in this warranty, specific limitations are shown below (Additional Warranty Exclusions). Bloomfield Industries Authorized Service Agencies are located in principal cities.

This warranty is valid in the United States and void elsewhere. Please consult your classified telephone directory or your food service equipment dealer; or, for information and other details concerning warranty, write to:

**Service Parts Department  
Bloomfield Industries  
P.O. Box 280  
Verdi, NV 89439**

**Phone: (888) 492-2782**

**Fax: (888) 492-2783**

## SERVICE POLICY AND PROCEDURE GUIDE ADDITIONAL WARRANTY EXCLUSIONS

1. Resetting of safety thermostats, circuit breakers, overload protectors, or fuse replacements unless warranted conditions are the cause.
2. All problems due to operation at voltages other than specified on equipment nameplates; conversion to correct voltage must be the customer's responsibility.
3. All problems due to electrical connections not made in accordance with electrical code requirements and wiring diagrams supplied with the equipment.
4. Replacement of items subject to normal wear, to include such items as knobs and light bulbs. Normal maintenance functions including adjustment of thermostats, microswitches, and replacement of fuses and indicating lights are not covered under warranty.
5. All problems due to inadequate water supply, such as fluctuating, or high or low water pressure.
6. All problems due to mineral/calcium deposits, or contamination from chlorides/chlorines. De-liming is considered a preventative maintenance function and is not covered by warranty.
7. Full use, care and maintenance instructions are supplied with each machine. Those miscellaneous adjustments noted are customer responsibility. Proper attention will prolong the life of the machine.
8. Travel mileage is limited to sixty (60) miles from an authorized Service Agency or one of its sub-agencies.
9. All labor shall be performed during normal working hours. Overtime premium shall be charged to the customer.
10. All genuine Bloomfield replacement parts are warranted for ninety (90) days from date of purchase on non-warranted equipment. **Any use of non-genuine Bloomfield parts completely voids any warranty.**
11. Installation, labor and job check-out are not considered warranty.
12. Charges incurred by delays, waiting time or operating restrictions that hinder the service technicians ability to perform services are not covered by warranty. This includes institutional and correctional facilities.

## SHIPPING DAMAGE CLAIMS PROCEDURE

**NOTE:** For your protection, please note that equipment in this shipment was carefully inspected and packaged by skilled personnel before leaving the factory. Upon acceptance of this shipment, the transportation company assumes full responsibility for its safe delivery.

### IF SHIPMENT ARRIVES DAMAGED:

1. **VISIBLE LOSS OR DAMAGE:** Be certain that any visible loss or damage is noted on the freight bill or express receipt, and that the note of loss or damage is signed by the delivery person.
2. **FILE CLAIM FOR DAMAGE IMMEDIATELY:** Regardless of the extent of the damage.

3. **CONCEALED LOSS OR DAMAGE:** if damage is unnoticed until the merchandise is unpacked, notify the transportation company or carrier immediately, and file "CONCEALED DAMAGE" claim with them. This must be done within fifteen (15) days from the date the delivery was made to you. Be sure to retain the container for inspection.

Bloomfield Industries cannot assume liability for damage or loss incurred in transit. We will, however, at your request, supply you with the necessary documents to support your claim.

## TABLE OF CONTENTS

WARRANTY STATEMENT	xi	Thank You for purchasing this Bloomfield Industries appliance.
SPECIFICATIONS	1	
FEATURES & OPERATING CONTROLS	2	
PRECAUTIONS & GENERAL INFORMATION	3	Proper installation, professional operation and consistent maintenance of this appliance will ensure that it gives you the very best performance and a long, economical service life.
AGENCY LISTING INFORMATION	3	
INSTALLATION INSTRUCTIONS	4	
OPERATION	6	
BREWING COFFEE	8	
CLEANING INSTRUCTIONS	9	
TROUBLESHOOTING SUGGESTIONS	10	This manual contains the information needed to properly install this appliance, and to use, care for and maintain or repair the appliance in a manner which will ensure its optimum performance.
SERVICING INSTRUCTIONS	11	
Deliming Instructions	16	
EXPLODED VIEW & PARTS LIST	18	
WIRING DIAGRAMS	23	

## SPECIFICATIONS

MODEL	STYLE	VOLTS	WATTS	AMPS 1ø	POWER SUPPLY CORD
8752 8752KFT	Decanter Brewer 5 Warmers	115/230	4000	19.4	None provided Wire directly to circuit

## APPLICABILITY

This manual applies to the following Bloomfield Industries products:  
 Model 8752 Integrity 5-Warmer Coffee Brewer  
 Model 8752KFT 5-Warmer Coffee Brewer

# FEATURES AND OPERATING CONTROLS

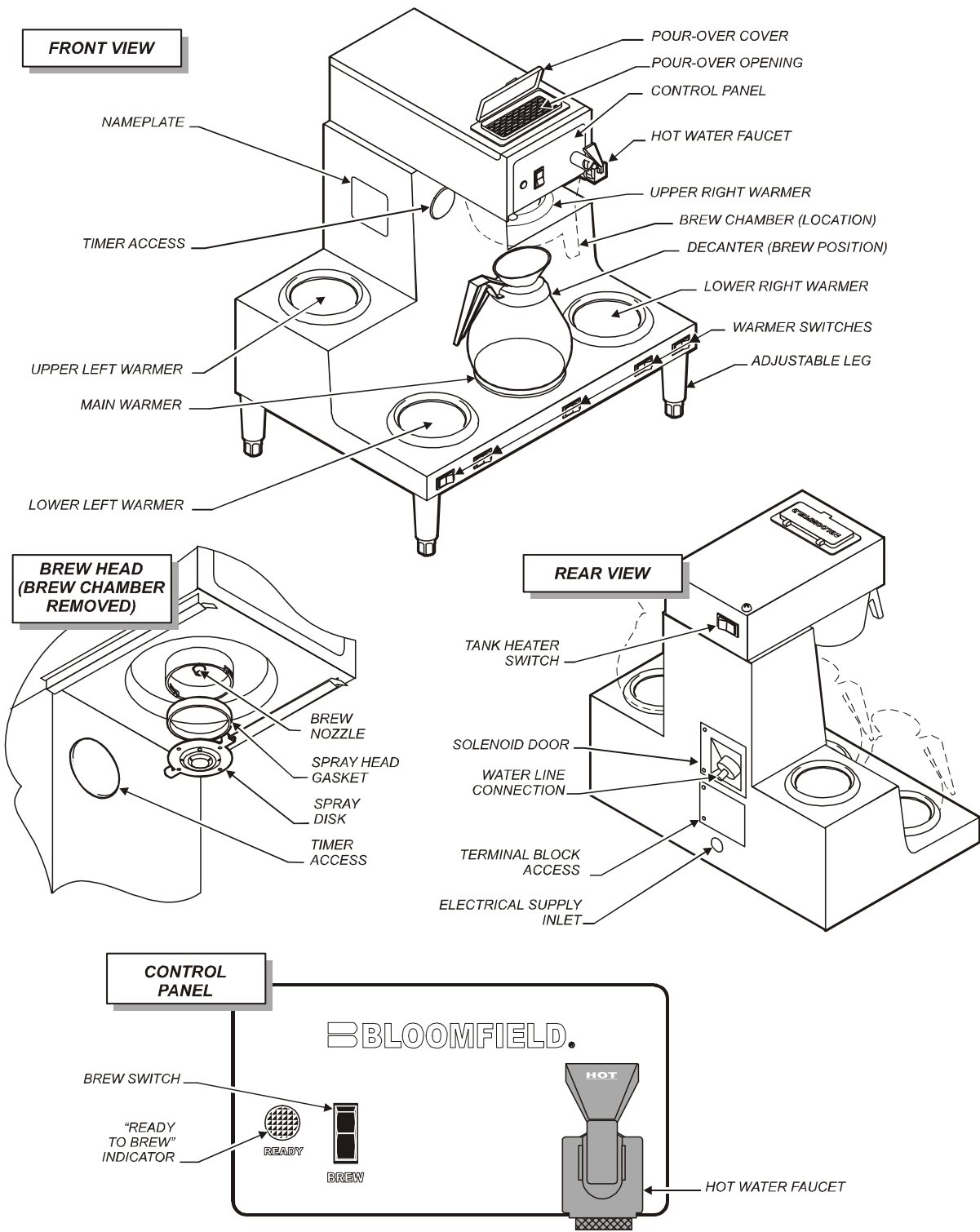

Fig. 1 Model 8752 Features and Operating Controls

## PRECAUTIONS AND GENERAL INFORMATION



### WARNING: ELECTRIC SHOCK HAZARD

All servicing requiring access to non-insulated components must be performed by qualified service personnel. Do not open any access panels which require the use of tools. Failure to heed this warning can result in electrical shock.



### WARNING: INJURY HAZARD

All installation procedures must be performed by qualified personnel with full knowledge of all applicable electrical and plumbing codes. Failure could result in property damage and personal injury.



### WARNING: ELECTRIC SHOCK HAZARD

Brewer must be properly grounded to prevent possible shock hazard. DO NOT assume a plumbing line will provide such a ground. Electrical shock will cause death or serious injury.



### WARNING: BURN HAZARD

This appliance dispenses very hot liquid. Serious bodily injury from scalding can occur from contact with dispensed liquids.

This appliance is intended for commercial use only.

This appliance is intended for use to brew beverage products for human consumption. No other use is recommended or authorized by the manufacturer or its agents.

This appliance is intended for use in commercial establishments, where all operators are familiar with the appliance use, limitations and associated hazards. Operating instructions and warnings must be read and understood by all operators and users.

Except as noted, this piece of equipment is made in the USA and has American sizes on hardware. All metric conversions are approximate and can vary in size.

The following trouble shooting, component views and parts lists are included for general reference, and are intended for use by qualified service personnel.

This manual should be considered a permanent part of this appliance. The manual must remain with the appliance if it is sold or moved to another location.



### CAUTION: ELECTRICAL DAMAGE

DO NOT plug in or energize this appliance until all *Installation Instructions* are read and followed. Damage to the Brewer will occur if these instructions are not followed.



### CAUTION: BURN HAZARD

Exposed surfaces of the appliance, brew chamber and decanter may be HOT to the touch, and can cause serious burns.

## AGENCY LISTING INFORMATION

This brewer is  and  listed under UL file E9253.

This brewer meets  Standard 4 only when installed, operated and maintained in accordance with the enclosed instructions.



## INSTALLATION

### READ THIS CAREFULLY BEFORE STARTING THE INSTALLATION

#### IMPORTANT:

To enable the installer to make a quality installation and to minimize installation time, the following suggestions and tests should be done before the actual unit installation is started:



#### CAUTION: ELECTRICAL DAMAGE

DO NOT plug in or energize this appliance until all Installation Instructions are read and followed. Damage to the Brewer will occur if these instructions are not followed.



#### CAUTION: UNSTABLE EQUIPMENT HAZARD

DO NOT operate brewer unless factory supplied adjustable legs are installed and properly adjusted.

It is very important for safety and for proper operation that the brewer is level and stable when standing in its final operating position. Provided adjustable legs must be installed at each corner of the unit. Failure to do so will result in movement of the brewer which can cause personal injury and/or damage to brewer.

**NOTE:** Water supply inlet line must meet certain minimum criteria to insure successful operation of the brewer. Bloomfield recommends 1/4" copper tubing for installation of less than 12 feet and 3/8" for more than 12 feet from a 1/2" water supply line.

REFER TO EXPLODED VIEWS FOR COMPONENT NAMES/ NUMBERS

Unpack the unit. Inspect all components for completeness and condition. Ensure that all packing materials have been removed from the unit.

Verify that the Spray Head Gasket and Spray Disk are properly installed.

#### LEVELING THE UNIT

Verify that provided adjustable legs are installed at each corner of the brewer.

Set Brewer in its operating location. Level the Brewer. A spirit level should be placed on the top of the unit, at the edge, as a guide when making level adjustments.

Level the unit from left to right and front to back by turning the adjustable feet. Be sure all four feet touch the counter to prevent tipping.

#### PLUMBER'S INSTALLATION INSTRUCTIONS

Brewer should be connected to a **POTABLE WATER, COLD WATER** line. Flush water line before connecting to Brewer.

DO NOT use a saddle valve with a self-piercing tap for the water line connection. Such a tap can become restricted by waterline debris. For systems that must use a saddle tap, shut off the main water supply and drill a 3/16" (minimum) tap for the saddle connection, in order to insure an ample water supply. Remember to flush the line prior to installing the saddle.

The brewer must be installed on a water line with average pressure between 20 PSI and 90 PSI. If your water pressure exceeds 90 PSI at anytime, a pressure regulator must be installed in the water supply line to limit the pressure to not more than 90 PSI in order to avoid damage to lines and solenoid.

## INSTALLATION (continued)

A water shut-off valve should be installed on the incoming water line in a convenient location (Use a low restriction type valve, such as a 1/4-turn ball valve, to avoid loss of water flow thru the valve).

NSF requires that the brewer be able to be moved for cleaning underneath. A flex line or loops of copper tubing will satisfy this requirement. See Figure 2 below.

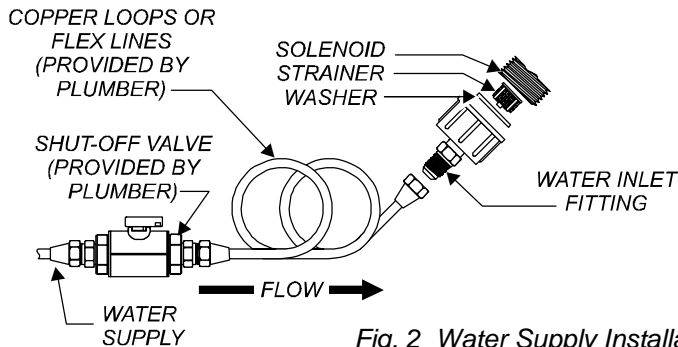

Fig. 2 Water Supply Installation

In some areas, local codes require a backflow preventer (check valve) to be installed on the inlet water line. If a backflow preventer is used, you must install a *water hammer arrester* in the incoming line, between the backflow preventer and the brewer inlet, as far away from the brewer as space will allow. This will relieve the excessive back pressures that can cause faucet leaks and solenoid malfunctions.

### ELECTRICIAN'S INSTALLATION INSTRUCTIONS

REFER TO ELECTRICAL SPECIFICATIONS - Page 1  
Check the nameplate to determine correct electrical service required for this installation.

**IMPORTANT:** Before connecting to electricity, make sure the brewer is connected to the water supply.

**IMPORTANT:** For power supply connections use COPPER WIRE only. Wiring must be suitable for at least 75°C. This brewer requires a dedicated electric circuit.

**Models 8752** must be wired by an electrician, and require a 115/230V 20A circuit (50/60 Hz, 2 hot legs / 1 neutral leg, plus ground). Remove rear panel to gain access to terminal block. Green terminal must be connected to a suitable building ground. Circuit must be capable of 4000 Watts. See figure 3 at right.

**IMPORTANT:** Wiring must be installed in approved solid or flexible conduit, and must be secured to the brewer with a strain relief (to be provided by the installer).

**NOTE:** This equipment must be installed to comply with applicable federal, state and local plumbing codes and ordinances.

### **WARNING** WARNING: SHOCK HAZARD

Brewer must be properly grounded to prevent possible shock hazard. **DO NOT** assume a plumbing line will provide such a ground. Electrical shock will cause death or serious injury.

**IMPORTANT:** Supply power must match nameplate for voltage and phase. Connecting to the wrong voltage will damage the brewer or result in decreased performance. Such damage is not covered by warranty.

**IMPORTANT:** Do not connect brewer to electrical power until you are ready to fill the tank. See instructions on page 6.

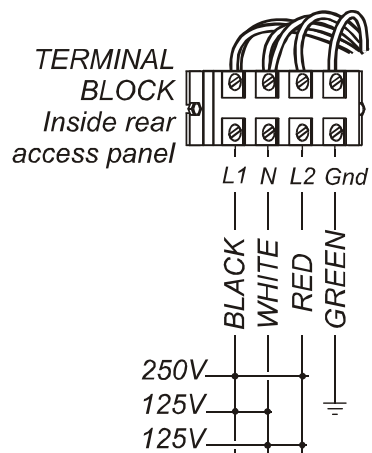

Fig. 3 Electrical Installation



## OPERATION

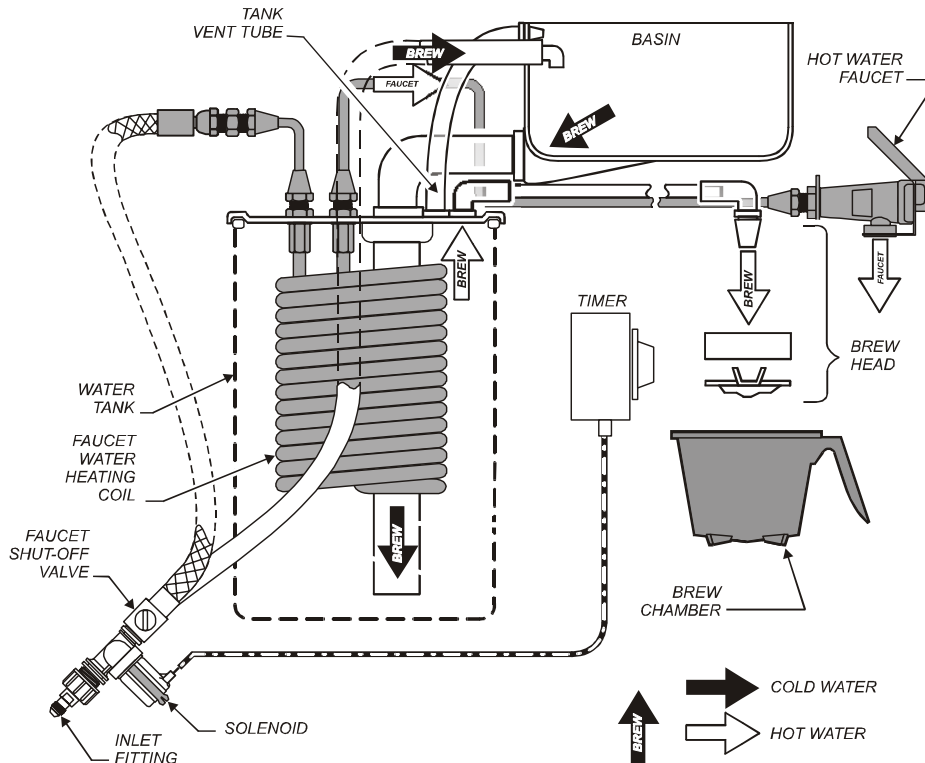
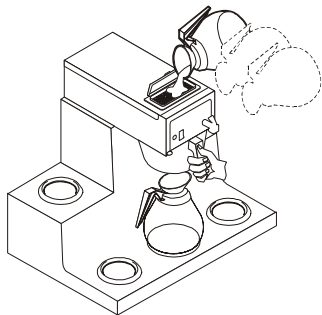

Fig. 4 Brewer Operation Diagram

### IMPORTANT:

Tank must be full of water before pressing TANK HEATER SWITCH "ON". Heating elements will be damaged if allowed to operate without being fully submerged in water. Damage caused by operating the brewer without water in the tank is **NOT COVERED BY WARRANTY**.



### START-UP

For initial start-up, or if the brewer has not been used for an extended period of time:

- ◆ Be sure spray disk and brew gasket are properly installed in the brew head.
- ◆ Be sure the water supply is properly connected and the water supply valve is turned ON.
- ◆ Be sure the WATER TANK IS FILLED

**BEFORE** connecting brewer to electrical power **THE WATER TANK MUST BE FILLED**. Place an empty decanter under the brew head. Lift the pour-over cover then pour warm tap water into the pour-over opening until water flows from the brew head. When water stops dripping from the brew head, empty the container.

Once the tank is full of water, connect the brewer to electrical power. Press the TANK HEATER SWITCH to "ON". The heating elements will begin heating the water in the tank. When the water has reached the proper temperature, the READY TO BREW light will glow.



## OPERATION (continued)

Water temperature is sensed by a thermobulb inserted into the water tank. This temperature signal is fed to the thermostat, which controls line power to the heating element.

The setpoint temperature is adjustable at the thermostat.

The element is protected from over-temperature by a hi-limit thermostat.

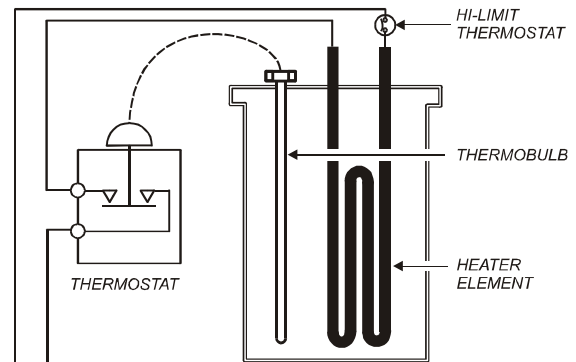

Fig. 5 Heat Control Diagram

## WATER FLOW

### POUR-OVER FEATURE

Pouring any amount of cold water into the pour-over opening and into the basin pan forces an identical amount of hot water out of the tank and through the spray head into the brew chamber.

### AUTOMATIC OPERATION

Pressing BREW button energizes the solenoid valve, allowing water from an external water supply to flow into the basin pan and then into the hot water tank. This forces an identical amount of hot water out of the tank and through the spray head into the brew chamber.

The solenoid uses a flow control device so that flow is consistent between 20 p.s.i. and 90 p.s.i.

Length of time the solenoid is open is controlled by the timer.

### HOT WATER FAUCET

The faucet water coil is submerged in the hot water tank and draws heat from the brew water. Water going to the water coil is not controlled by the solenoid valve.

The faucet is at supply water pressure any time the faucet shut-off valve is OPEN.

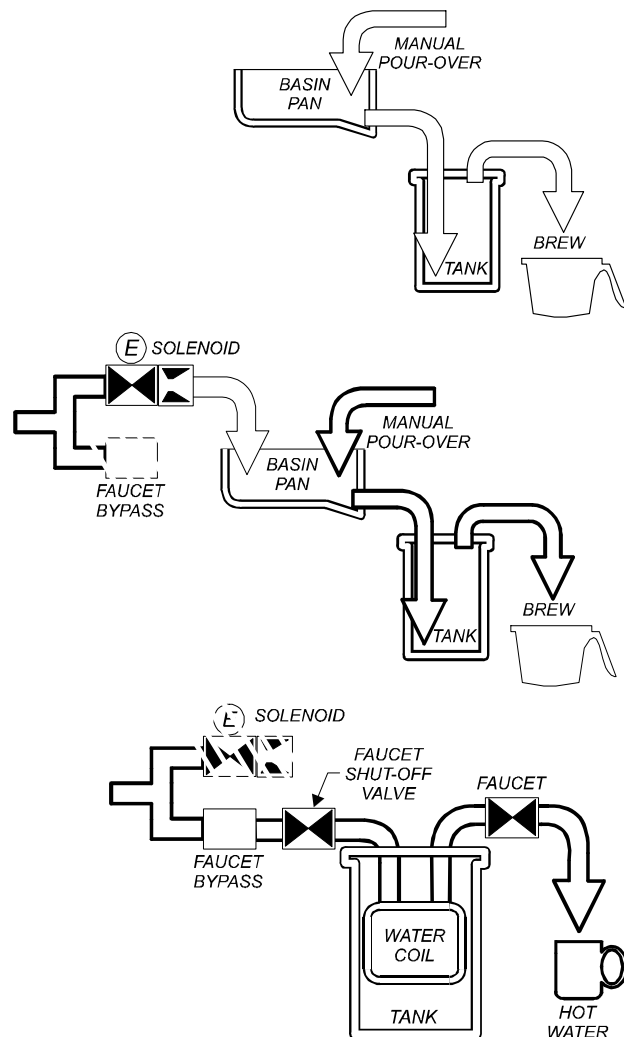

Fig. 6 Water Flow Diagram

## BREWING COFFEE



### CAUTION: BURN HAZARD

Exposed surfaces of the brewer, brew chamber and decanter may be HOT to the touch, and can cause serious burns.



### CAUTION: BURN HAZARD

To avoid splashing or overflowing hot liquids, ALWAYS place an empty decanter under the brew chamber before starting the brew cycle. Failure to comply can cause serious burns.



### CAUTION: BURN HAZARD

After a brew cycle, brew chamber contents are HOT. Remove the brew chamber and dispose of used grounds with care. Failure to comply can cause serious burns.



**NOTE:** Water for the hot water faucet is heated in a coil inside of the water tank. Use of the faucet will not affect the volume of water delivered for a brew. However, overuse of the faucet during a brew may lower the temperature of the brew water.

### A. PREPARATION

Place one (1) genuine Bloomfield paper filter in the brew chamber. Add a pre-measured amount of fresh coffee grounds. Gently shake the brew chamber to level the bed of grounds. Slide the brew chamber into place under the brew head.

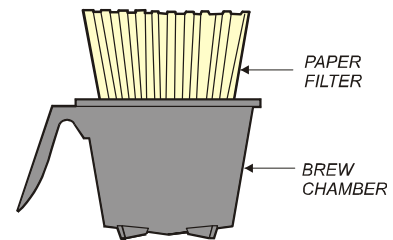

Fig. 7 Brew Chamber

### B. POUR-OVER OPERATION

**NOTE:** Any Integrity™ brewer can be used in the pour-over mode.

BE sure "READY TO BREW" light is lit.

Place the appropriate *EMPTY* decanter in place under the brew chamber.

Fill a decanter with tap water. Lift the pour-over cover and pour the entire contents of the decanter into the pour-over opening, which will fill the basin.

Water from the basin will displace a like amount of heated water from the tank. The hot water will be forced into the brew head where it will spray over the bed of grounds. Freshly brewed coffee will begin to fill the container under the brew chamber. When the flow and all dripping stops, the coffee is ready to serve.

Discard the contents of the brew chamber. Rinse the brew chamber in a sink. When the "HEAT" light goes out, the brewer is ready for another brew cycle.

### C. AUTOMATIC OPERATION

BE sure "READY TO BREW" light is lit.

Place the appropriate *EMPTY* decanter in place under the brew chamber.

Press the "BREW" switch. The solenoid will open for an amount of time determined by the timer setting, admitting a measured quantity of water into the tank.

Inlet water will displace a like amount of heated water from the tank. The hot water will be forced into the brew head where it will spray over the bed of grounds. Freshly brewed coffee will begin to fill the container under the brew chamber.

When the flow and all dripping stops, the coffee is ready to serve.

Discard the contents of the brew chamber and rinse it in a sink. When the "READY TO BREW" light glows, the brewer is ready for another brew cycle.

## CLEANING INSTRUCTIONS

### PROCEDURE: Clean Coffee Brewer

PRECAUTIONS: Disconnect brewer from electric power.  
Allow brewer to cool.

FREQUENCY: Daily

TOOLS: Mild Detergent, Clean Soft Cloth or Sponge  
Bristle Brush, Bottle Brush

1. Disconnect brewer from electric power.  
Allow brewer to cool before cleaning.
2. Remove and empty decanters.
3. Remove and empty brew chamber.
4. Remove the spray disk from the brew head (See figure 8):  
Press up on the spray disk ears, then turn the disk to the left to unlatch. Remove the gasket from inside the brew head.
5. Wipe inside of brew head and area around the brew head with a soft clean cloth or sponge moistened with clean water.
6. Wash the spray disk in a sink using warm water and a mild detergent. A bristle brush may be used to clear clogged spray holes. Rinse the spray disk with clean water and allow to air dry.
7. Wash the brew chamber in a sink using warm water and a mild detergent. A bristle brush may be used to clean the inside. Rinse with clean water and allow to air dry.
8. Wipe the exterior of the brewer with a soft clean cloth or sponge moistened with clean water.
10. Reinstall the gasket *INSIDE* the brew head, then reinstall the spray disk.
11. Reinstall the brew chamber.
12. Decanters may be washed in a dishwasher or sink.

Procedure is complete



### CAUTION: BURN HAZARD

Brewing and serving temperatures of coffee are extremely hot.  
Hot coffee will cause serious skin burns.



### CAUTION: SHOCK HAZARD

Do not submerge or immerse brewer in water.

### IMPORTANT:

DO NOT use steel wool, sharp objects, or caustic, abrasive or chlorinated cleansers to clean the brewer or airtops.

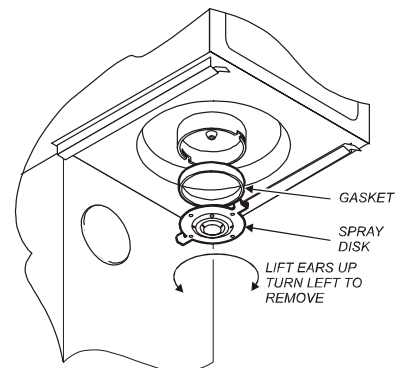

Fig. 8 Cleaning

## TROUBLESHOOTING SUGGESTIONS

SYMPTOM	POSSIBLE CAUSE	SUGGESTED REMEDY
Water won't heat	Brewer unplugged or circuit breaker tripped	Check power supply cord Check / reset circuit breaker
	Thermostat set too low	Set for desired temperature
	Hi-Limit thermostat tripped	Allow to cool Reset hi-limit
	Damaged internal component or wiring	Examine wiring & connectors, thermostat and heating element Repair/replace as needed
Trips hi-limit safety at start-up	No water or too little water added at start-up	Be sure to add sufficient water prior to energizing
Coffee level low (pour-over)	Not enough water poured in	Increase water amount
	Too much coffee grounds	Adjust amount of grounds
Coffee level too high or low (automatic)	Timer out of adjustment	Adjust timer
Brew chamber overflows	Too many filter papers or wrong filter paper	Use one (1) genuine Bloomfield filter per brew
	Brew chamber dispense hole plugged	Thoroughly clean brew chamber
	Too much coffee or too fine a grind	Adjust coffee amount and grind
Sprays water from brew head incorrectly	Spray gasket missing or improperly installed	Check/reinstall gasket on INSIDE of brew head
	Spray disk plugged	Clean spray disk
No brew (automatic)	Water supply OFF	Turn water supply ON
	Water line strainer plugged	Clean strainer
	Water filter (if used) plugged	Replace filter element
	Damaged BREW switch	Replace switch
	Damaged internal component or wiring	Examine wiring & connectors, brew timer and solenoid Repair/replace as needed
No flow from hot water faucet	Faucet valve turned OFF	Turn faucet valve ON
	Faucet plugged	Disassemble faucet, clean
Poor coffee quality	Water not hot enough	Adjust water temp 195-205°F
	<p>Also:                      Keep brewer, and decanters clean.                      Install a taste and odor filter in water supply, and replace cartridges regularly.                      Use a quality coffee with a consistent roast. Use proper grind and amount of coffee per brew.</p>	

## SERVICING INSTRUCTIONS

### ACCESS PANELS

#### TOP PANEL:

Remove top panel to access hot water tank, thermostat, heating elements, brew circuit tubing and faucet tubing. Top panel is held by two screws at the front and a retaining lip at the rear.

#### FRONT PANELS:

Remove upper front panel to access timer and hi-limit. Remove button plugs for simple adjustments or reset. Upper front panel is held by two screws at the bottom and a retaining lip at the top.

#### SOLENOID DOOR:

Remove solenoid door to access solenoid and tubing connections. Solenoid door is held by two screws and a retaining lip.

#### TERMINAL BLOCK ACCESS:

Remove door to access wiring connections. Access door is held by two screws and a retaining lip.

#### WARMER PLATES:

Warmer plates unscrew counterclockwise to access warmer elements and electrical connections.



### CAUTION: SHOCK HAZARD

Opening access panels or removing warmer plates on this brew may expose uninsulated electrical components. Disconnect brewer from electrical power before removing any panel.

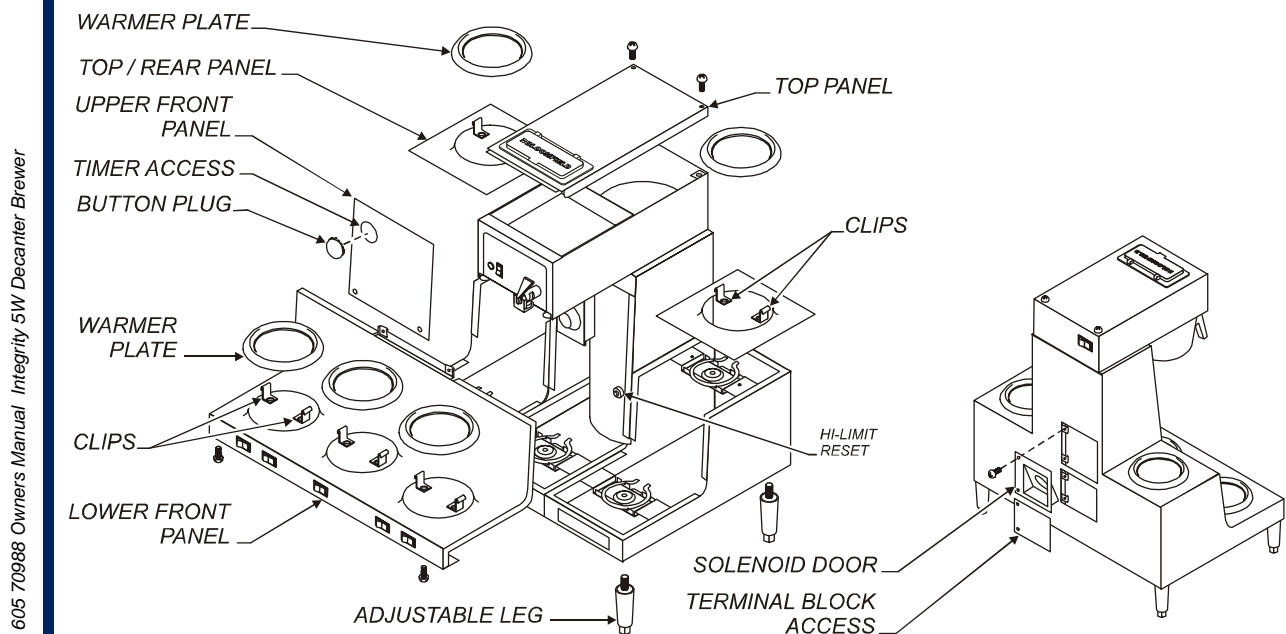

605 70988 Owners Manual Integrity 5W Decanter Brewer

Fig. 9 Access Panels

## SERVICING INSTRUCTIONS (continued)

### TEMPERATURE ADJUSTMENT

Unplug power cord or turn circuit breaker OFF. Remove top panel.

Pull vent tube out of tank lid and insert a thermometer of known accuracy in hole. Reconnect brewer to electrical power. Place empty container under brew chamber. Energize brewer and allow unit to heat. When READY TO BREW light glows, read the temperature displayed on thermometer.

Adjust WATER TEMP by turning shaft of thermostat; clockwise increases temperature. Refer to Table 1 below for proper brewing temperature based on altitude.

Upon completion, remove thermometer and reinstall the plug.

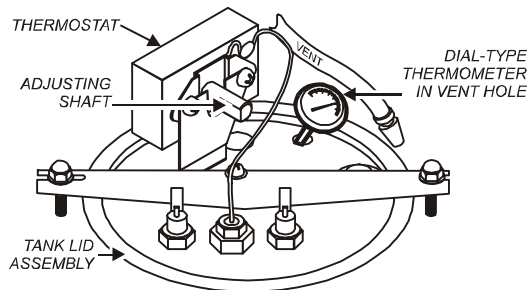

Fig. 10 Checking and Adjusting Brew Temperature

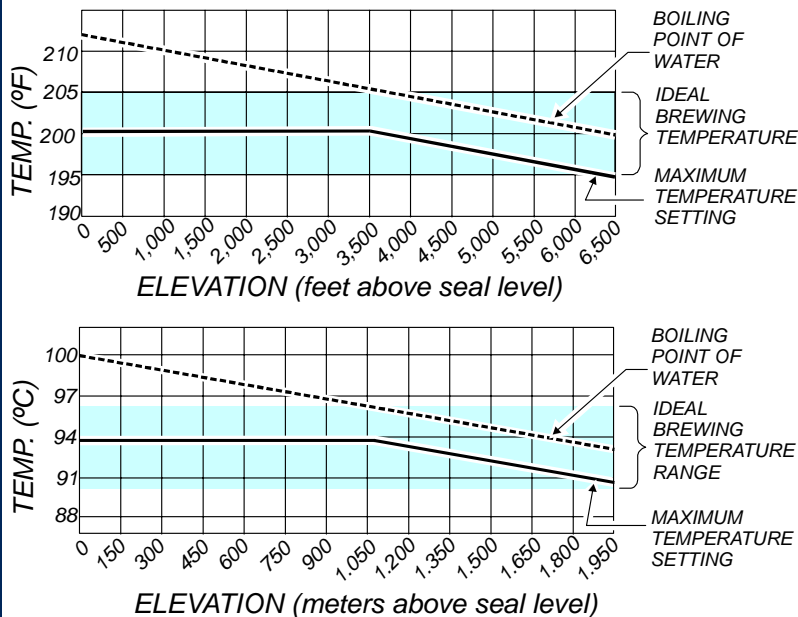

Table 1 Boiling Temperature by Altitude



### CAUTION: SHOCK HAZARD

These procedures involve exposed electrical circuits. These procedures are to be performed by qualified technical personnel only.

### NOTE:

Optimum brewing temperature range is 195°F to 205°F (90°C to 96°C).

### IMPORTANT:

A mechanical thermostat will maintain temperature within  $\pm 5^\circ\text{F}$ . To prevent boiling water in the brewer, thermostat should be adjusted to a maximum temperature equal to the local boiling temperature minus 5°F.

## SERVICING INSTRUCTIONS (continued)

### TIMER ADJUSTMENT

The amount of water dispensed automatically during a brew cycle is controlled by the timer.

Place empty decanter under brew chamber. Press BREW button. Brewer should dispense one decanter of water. To adjust amount:

Remove brew chamber and button plug. Adjust knob on timer; clockwise increases time. Run several cycles to check amount of water delivered. Replace button plug.

### REMOVE TANK LID ASSEMBLY

Unplug brewer or turn circuit breaker *OFF*. Turn *OFF* water supply. Remove top panel. Pull vent tube and inlet elbow out of basin pan.

Pull water inlet tube out of basin pan. Remove basin pan.

Disconnect faucet coil at inlet and outlet.

Disconnect all wiring from thermostat and heating element.

Loosen acorn nuts on tank hold-down bracket. Remove hold-down bracket by sliding short slotted end off of locking stud and lifting it off. Remove cover assembly by lifting it straight up.

Reassemble in reverse order.

### REPLACE THERMOSTAT

Unplug brewer or turn circuit breaker *OFF*. Turn *OFF* water supply. Remove top panel.

Disconnect all wiring from thermostat only. Loosen and free jam nut from pass-thru fitting securing temperature sensing bulb. Remove two screws holding thermostat to bracket.

Lift out thermostat, sensing bulb and thermostat gasket.

Reassemble in reverse order.

### REPLACE HEATING ELEMENT

Remove tank lid assembly per above.

Remove two hex nuts holding element to cover. Pull element from mounting holes.

Reassemble in reverse order.

**IMPORTANT:** Water pressure must be between 20 p.s.i and 90 p.s.i. flowing pressure. If water pressure exceeds this value, or if water pressure varies greatly, a pressure regulator must be installed in the water supply line.

**IMPORTANT:** Before setting assembly into tank, make sure tank lid gasket is properly seated on flange of lid. *DO NOT OVER-TIGHTEN.*

**IMPORTANT:** When mounting thermostat, be sure a new seal washer is placed below the fitting on the capillary line. Push sensing bulb thru tank lid until fitting seats. Tighten capillary lock nut only enough to ensure no water leakage. Excessive tightening is not necessary.

**IMPORTANT:** When replacing heating element, also replace seal gaskets.



## SERVICING INSTRUCTIONS (continued)

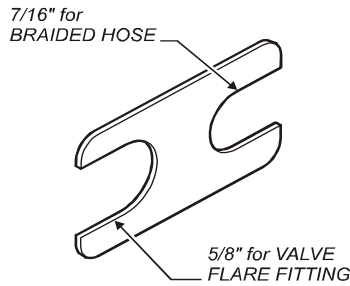

P/N 86660 Braided Hose Wrench

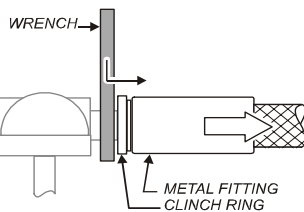
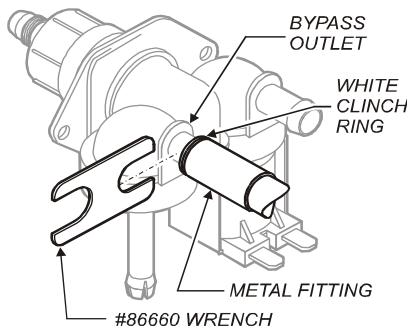

SLIDE WRENCH BETWEEN VALVE AND HOSE FITTING  
PRESS CLINCH RING TOWARD METAL FITTING TO RELEASE

Fig. 11 Remove Faucet Supply from Solenoid

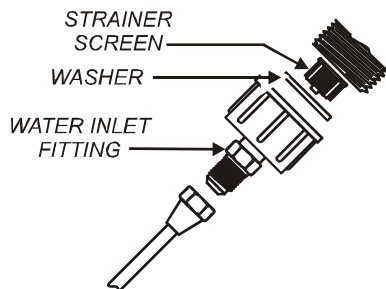

Fig. 12 Clean Strainer Screen

### REPLACE SOLENOID

Symptom: Automatic brewer will not flow water; or, automatic brewer drips continuously from brew head.

Unplug power cord or turn circuit breaker *OFF*. Turn *OFF* and disconnect water supply from brewer inlet fitting.

Unscrew water inlet fitting from solenoid.

Remove two screws holding access door in place. Remove two screws holding solenoid to door.

Disconnect wiring from solenoid.

Slide the 7/16" end of the wrench between the valve body and the white ring on the extreme end of the metal hose fitting.

Pressure on the white ring toward the metal ferrule releases the clinch ring, allowing the hose to be easily slid off of the solenoid bypass outlet.

Transfer solenoid bracket to new solenoid.

Reinstall hose by pressing end of hose onto bypass outlet until it is fully seated.

Reassemble in reverse order.

### CLEAN SOLENOID SCREEN

Symptom: Automatic brewer will not flow water.

Unplug power cord or turn circuit breaker *OFF*. Turn *OFF* and disconnect water supply from brewer inlet fitting.

Unscrew water inlet fitting from solenoid.

Using needle-nose pliers, withdraw strainer screen from solenoid. Clean screen under faucet. A stiff bristle brush may be used if necessary.

Reinsert screen in solenoid. Be careful to maintain correct orientation. (The *OPEN END* of the screen goes in *FIRST*.)

Reassemble in reverse order.

## SERVICING INSTRUCTIONS (continued)

### REPLACE TIMER ASSEMBLY

Unplug power cord or turn circuit breaker OFF.

Remove front panel. Remove knob and three screws holding timer to bracket. Disconnect wiring to timer.

Reassemble in reverse order.

Adjust timer as described on page 13

### REPLACE HOT WATER FAUCET COIL

Symptom: Brewer drips continuously from brew head, except when faucet valve is turned OFF.

Remove tank lid assembly per above.

Remove two hex nuts hot water coil to cover. Pull coil from mounting holes.

Reassemble in reverse order.

### REPAIR HOT WATER FAUCET

Remove top panel and turn faucet valve OFF.

Unscrew aerator cap from faucet and remove handle retaining clip. Do not let faucet body turn.

Pull bonnet assembly from faucet body.

Examine the interior of the faucet body and the surface of the seat cup. Clean out any debris in the faucet body, using a stiff bristle brush if necessary.

Examine the aerator. Clean any debris from the screen or flow straightener, using a stiff bristle brush if necessary.

Reassemble in reverse order.

### REPLACE BREW READY LIGHT or BREW BUTTON

Unplug power cord or turn circuit breaker OFF.

Using Switch Removal Tool (p/n 83209) or a thin screwdriver, pry light or switch from mounting hole. Disconnect leads.

Reassemble in reverse order.

**IMPORTANT:** When replacing water faucet coil, also replace seal gaskets.

**NOTE:** Any abrasion or roughness on the flat end of the seat cup will require replacing the seat cup:

Work the seat cup out of the bonnet and off of the end of the stem.

Install a new seat cup, making sure the knob on the stem is fully inserted into the pocket of the seat cup, and the skirt of the seat cup is fully inserted into the bonnet.

## SERVICING INSTRUCTIONS (continued)



### **CAUTION:** **CHEMICAL BURN** **HAZARD**

Deliming chemicals may be caustic. Wear appropriate protective gloves and goggles during this procedure. Never siphon deliming chemicals or solutions by mouth. This operation should only be performed by qualified and experienced service personnel.

### **IMPORTANT:**

DO NOT spill, splash or pour water or deliming solution into or over any internal component other than the inside of the water tank.

### **IMPORTANT:**

DO NOT allow any internal components to come into contact with the deliming solution. Take care to keep all internal components dry.

**NOTE:** Repeat steps 4 thru 5 as required to remove all scale and lime build-up.

### **PROCEDURE: Delime the Water Tank**

**PRECAUTIONS:** Disconnect brewer from electric power. Allow brewer to cool.

**FREQUENCY:** As required (Brewer slow to heat)

**TOOLS:** Deliming Solution  
Protective Gloves, Goggles & Apron  
Mild Detergent, Clean Soft Cloth or Sponge  
Bristle Brush, Bottle Brush  
Large Sink (or other appropriate work area)

1. Unplug power cord. Turn off the water shut-off valve and disconnect the water supply line from the brewer inlet fitting.
2. Remove the tank lid assembly as described on page 13.
3. Remove the water tank from the brewer body by lifting straight up. Empty all water from the tank. Set the tank back into the brewer.
4. Mix 2 quarts of deliming solution according to the manufacturer's directions. Carefully pour the deliming solution into the water tank. Lower the lid assembly back onto the tank. Allow to sit for 30 minutes, or as directed by the manufacturer.
5. At end of soaking period, remove lid assembly from tank. Thoroughly rinse internal components of lid assembly with clear water. Using a stiff bristle brush, scrub the heating element and faucet water coil to remove lime and calcium build-up. Rinse with clean water. Store lid assembly in a safe location.
6. Remove the tank from the brewer and empty. Using a stiff bristle brush, scrub the interior of the water tank to remove lime and calcium build-up. Rinse with clean water.

## SERVICING INSTRUCTIONS (continued)

7. Set the tank back into the brewer. Reassemble the tank lid to the water tank. Make sure the gasket is properly in place, then reinstall lid clamps.
8. Reinstall wiring to heating element and thermostat. Reassemble piping for the faucet. Verify that all internal components are dry, then reinstall the top panel.
10. Reconnect brewer to electrical supply and reconnect water supply.
11. Install the brew chamber without filter paper or grounds. Run at least three full brew cycles and discard all water generated.
12. Brewer is ready to use.

**NOTE:** Normally, silicone hoses do not need to be delimed. Should deliming hoses become necessary, Bloomfield recommends replacing the hoses.

## EXPLODED VIEW & PARTS LIST

### CABINET ASSEMBLY

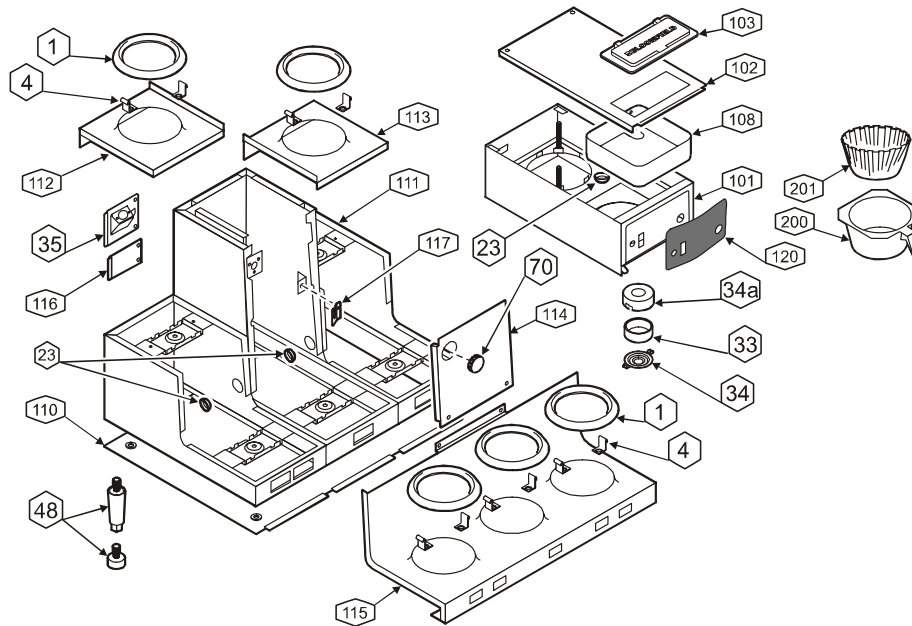

ITEM	PART NUMBER	DESCRIPTION
1	8700-16	PLATE, WARMER COVER
4	8543-80	CLIP, MOUNTING
23		BUSHING, HEYCO 1/8
33	8543-42	GASKET, SPRAYHEAD
34	82727	SPRAY DISK, EMBOSSED
34a	8543-85	RETAINER, SPRAY DISK (DRILL & RIVET REQUIRED TO INSTALL)
35	85089	DOOR, SOLENOID
48	8516-150	LEG SET, BLACK PLASTIC (pk 4)
	81732	LEG ASSY 1"
70	8706-75	BUTTON PLUG, 2"
101		ASSEMBLY, BASIN BODY
102	8542-6	COVER, BASIN TOP (INCLUDES 86666 POUR-OVER ASSY)
103	86666	ASSEMBLY, POUR OVER, PLASTIC
108	8541-21	BASIN
110	8751-17	PLATE, BOTTOM, 8750-SERIES
111		ASSEMBLY, BODY 8750-SERIES
112		COVER, UPPER LEFT
113		COVER, UPPER RIGHT
114		COVER, FRONT UPPER
115		COVER, FRONT LOWER
116	86903	ACCESS, TERMINAL BLOCK
117	8718-48	BRACKET, HI-LIMIT MOUNTING
120	86871	LABEL, BASIN FRONT (8752)
	86873	LABEL, BASIN FRONT (8752KFT)
200	8942-6B	BREW CHAMBER, BLACK PLASTIC
201	POF	FILTER PAPER (CS 1000)

## EXPLODED VIEW & PARTS LIST (continued)

### ELECTRICAL COMPONENTS

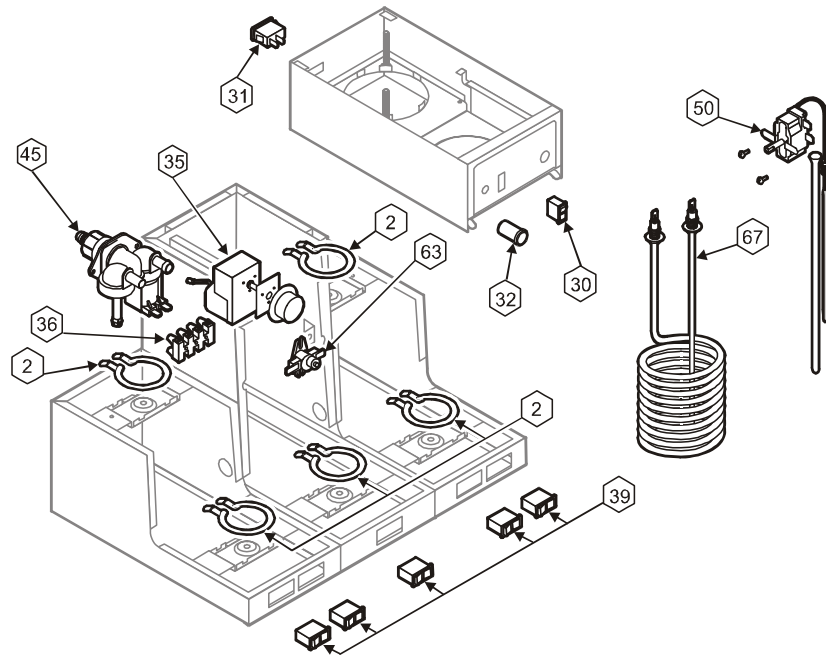

ITEM	PART NUMBER	DESCRIPTION
2	8572-18	ELEMENT, WARMER 120V 100W
30	8707-55	SWITCH, BREW (MOMENTARY)
31	8528-40	SWITCH, TANK HEATER 240V 20A
32	8738-2	INDICATOR LIGHT 120V GREEN
35	8718-1	TIMER W/KNOB 2-MIN
36	8552-18	TERMINAL BLOCK 4P
39	86945	SWITCH, WARMER
45	85685	SOLENOID 120V W/ BYPASS .75GPM
50	86280	THERMOSTAT 199°F
63	8552-50	HI-LIMIT SAFETY MANUAL RESET
67	8716-1	ELEMENT, HEATER 230V 3500W

## EXPLODED VIEW & PARTS LIST

### HOT WATER TANK ASSEMBLY

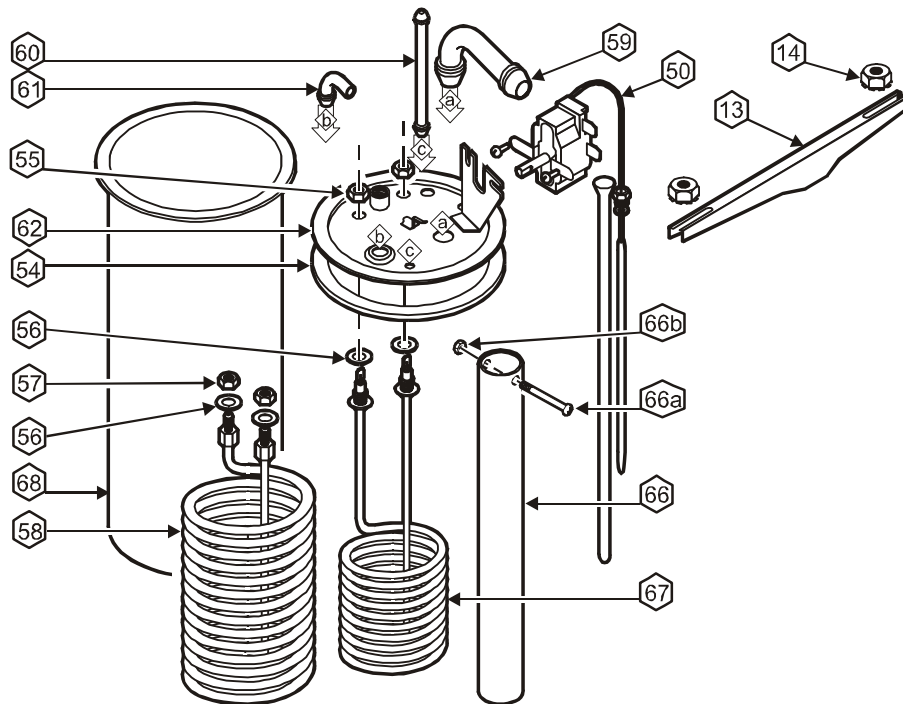

ITEM	PART NUMBER	DESCRIPTION
13	8043-5	HOLD-DOWN STRAP
14	8942-92	NUT 8-32 HEX KEPS
50	86280	THERMOSTAT 199°F
54	8043-12	GASKET, TANK COVER
55	8043-28	NUT, HEX 1/2-20 BRASS
56	8043-30	GASKET, SEAL
57	8941-21	NUT, HEX 7/16-20 BRASS
58	8540-6	HOT WATER COIL
59	8043-8	ELBOW, INLET
60	8043-15	VENT TUBE
61	8043-11	ELBOW, OUTLET
62	8514-68	TANK COVER, 8-HOLES
66	8043-24	WATER INLET TUBE
66a	8543-73	SCREW, 4-40 x 1 PH
66b	8543-74	NUT, HEX 4-40
67	8716-1	ELEMENT, HEATING 230V 3500W
68	8043-10	TANK BODY



## EXPLODED VIEW & PARTS LIST (continued)

### PLUMBING COMPONENTS

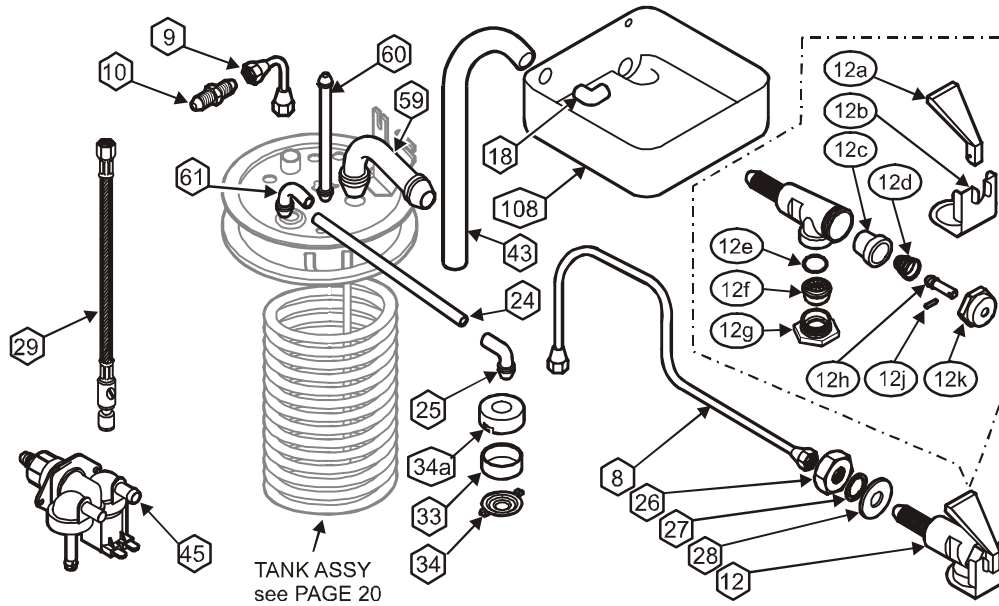

ITEM	PART NUMBER	DESCRIPTION
8	8540-3	ASSEMBLY, FORMED TUBE FAUCET SUPPLY
9	86904	TUBE, FORMED ASSEMBLY 1/4FF x 1/4 FF
10	80154	FITTING, UNION 1/4MF x 1/4MF
12*	82556	ASSEMBLY, FAUCET
24	8043-26	TUBE, BREW OUTLET METAL
25	8043-13	ELBOW, BREW SPRAY
26	82680	NUT, HEX 7/16-20 Ni
27	8551-100B	WASHER, LOCK 7/16"
28	82681	WASHER, FLAT 15/32 x 1-1/8 x .048 SS
29	85778	ASSEMBLY, BRAIDED TUBE W/BALL VALVE 14"
33	8543-42	GASKET, SPRAYHEAD
34	82727	SPRAY DISK, EMBOSSED
34A	8543-85	RETAINER, SPRAY DISK (DRILL & RIVET REQUIRED TO INSTALL)
43	86905	TUBE, BASIN WATER INLET 11"
45*	85685	SOLENOID 120V W/ BYPASS .75GPM
59	8043-8	ELBOW, TANK WATER INLET
60	8043-15	VENT TUBE
61	8043-11	ELBOW, TANK WATER OUTLET
108	8541-21	BASIN PAN

\* For REPAIR KITS see page 22.

## EXPLODED VIEW & PARTS LIST (continued)

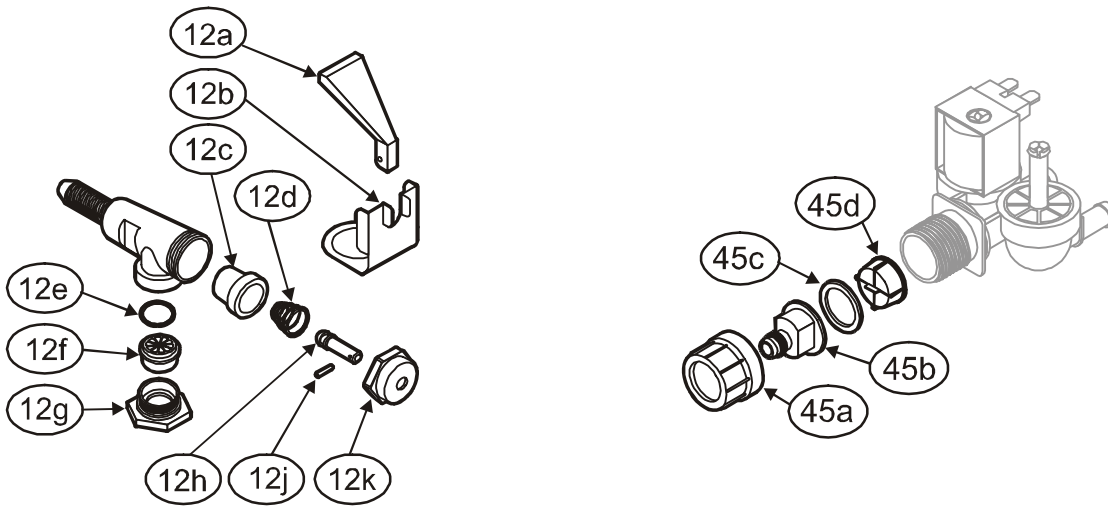

### SERVICE KITS

#### FAUCET REPAIR KITS

- |       |   |
|-------|---|
| 82573 | Handle (item 12a)   |
| 82575 | Seat Cup (item 12c)   |
| 82576 | Faucet Repair Kit (Includes 12a Handle, 12c Seat Cup, 12d Spring, 12h Stem, 12j Pin & 12k Bonnet) |
| 82682 | Retainer Clip (item 12b)  |
| 84804 | Aerator Replacement Kit (Includes 12e O-Ring, 12f Aerator Disk & 12g Aerator Cap)                 |
| 84870 | Aerator Repair Kit (Includes 12e O-Ring & 12f Aerator Disk)                                       |

#### SOLENOID REPAIR KITS

- |       |  |
|-------|--|
| 85218 | Inlet Fitting Kit (items 45-10, 45-11, 45-12, 45-13) |
| 85219 | Inlet Strainer (item 45-13)                          |

# WIRING DIAGRAM

## MODELS 8752 & 8752KFT

VOLTS	115/230 VOLTS 60 Hz 1 $\phi$
WATTS	4000 WATTS
AMPS	19.4 AMPS

p/n 72169 Rev. B

NOTE: Switches and panels are shown from the rear of the brewer.

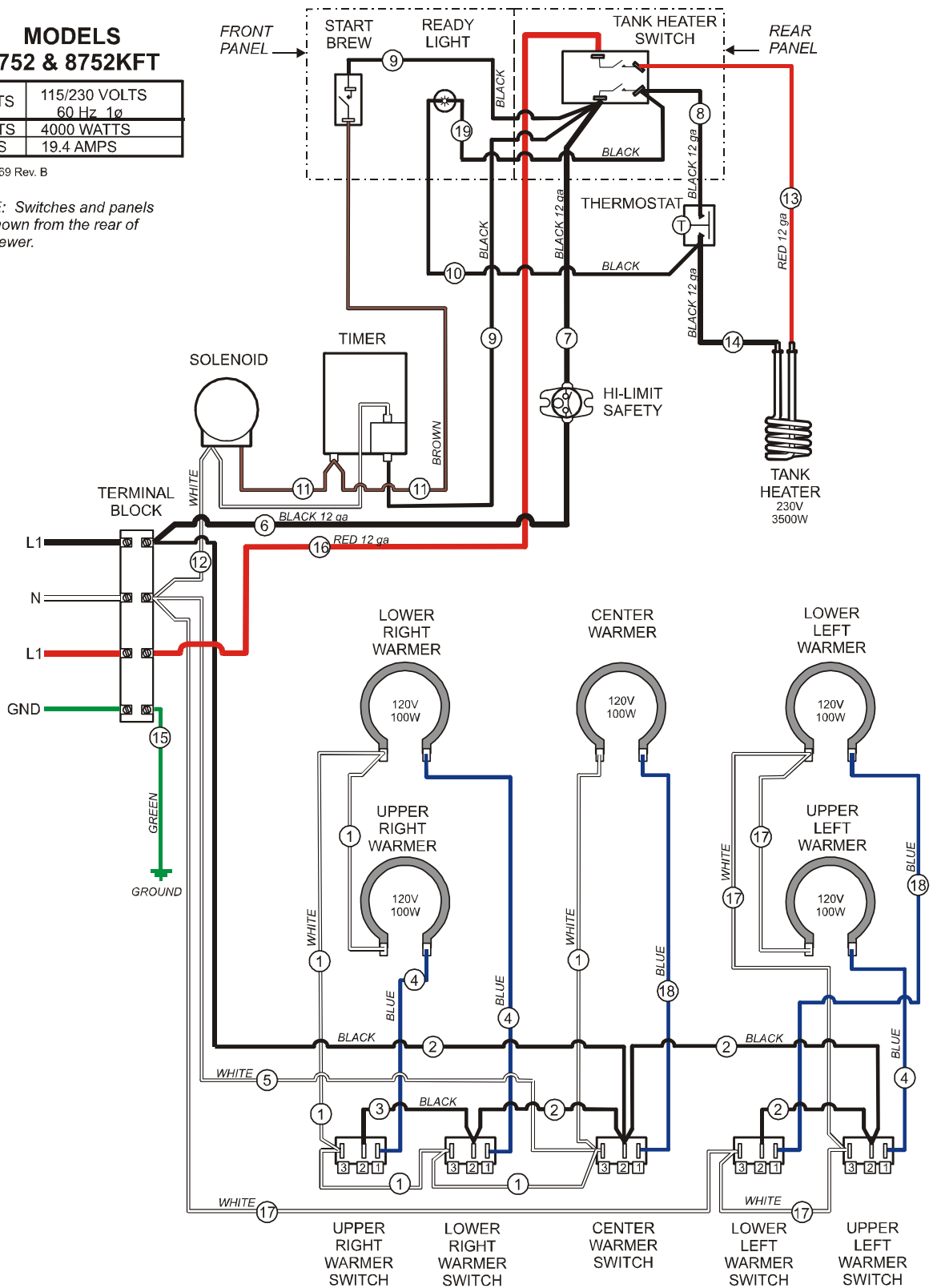

# CFESA

Commercial Food Equipment Service Association

Bloomfield Industries proudly supports CFESA  
Commercial Food Equipment Service Association

**SERVICE TRAINING - QUALITY SERVICE**



**CUSTOMER SATISFACTION**



**BLOOMFIELD**

**Bloomfield Industries, Inc.**  
**Division of Carrier Commercial Refrigeration**

**In US and Canada**

Telephone: 775-689-5700

Fax: 888-492-2783

Fax: 800-356-5142 (*for orders only*)

website: [www.wellsbloomfield.com](http://www.wellsbloomfield.com)

**PRINTED IN UNITED STATES OF AMERICA**