

Tanaka



Parts Catalog



Hedge Trimmer

Model: THT-240

THT-240

OPTIONS AND ACCESSORIES

PERFECT MIX® 2-Cycle Engine Oil

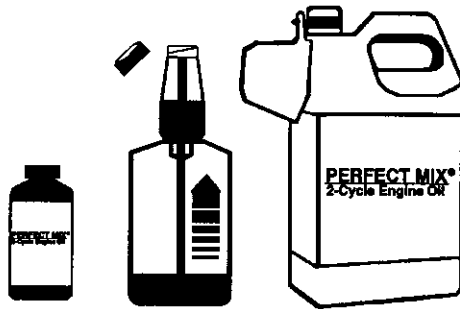

- 700109 2.8 oz. Bottle, 1 Gallon Size (24*)
700108 16 oz. Self-measuring Bottle (24*)
700110 1 Gallon Jug Commercial Size (6*)
* Case Quantity

MANUALS & CATALOGS

044511A	Owner's Manual
DPL-HT240-HST	Parts Catalog

SPECIAL TOOLS

006-29326-000	Flywheel Remover-	001-29000-000	Tachometer
009-29323-500	Piston Pin Remove	070-2000W-500	Pressure Tester
037-29476-522	Clutch Remover	070-2000W-501	Carb. Tool Kit

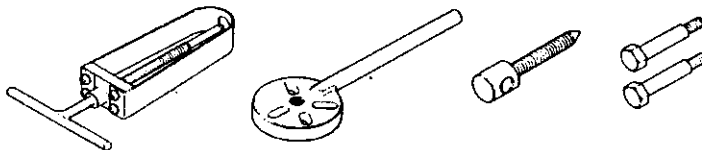

FIG. 1 ENGINE

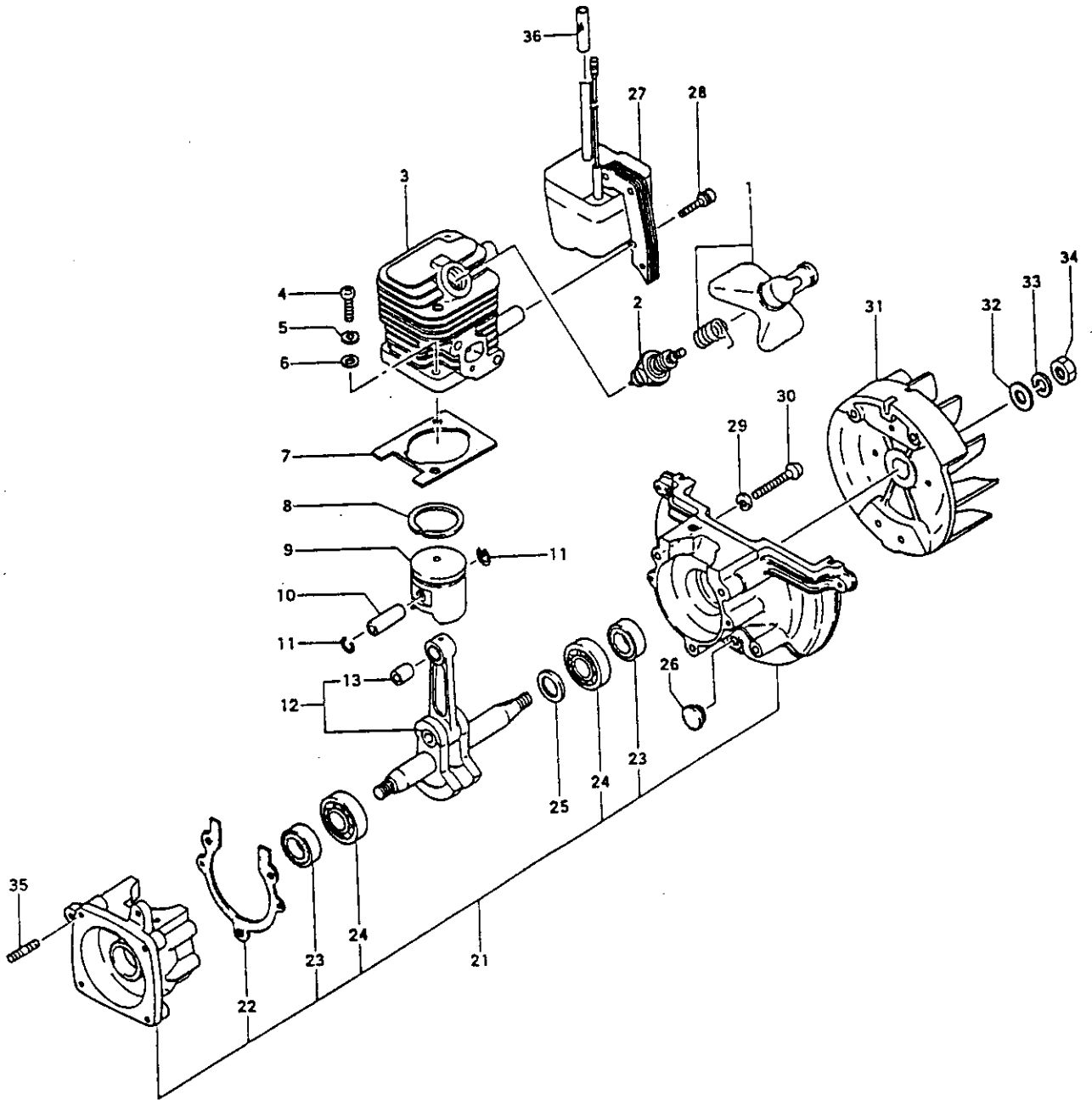

FIGURE 1

THT-240 PARTS LISTING

REF.	PART NO.	PART DESCRIPTION	Q	C	S	SERIAL NO.	REMARKS
1	157-06500-91	CAP,SPARK PLUG ASSY	1		D		
2	018-11660-21	PLUG,SPARK	1		B		
3	002-06500-201	CYLINDER	1		C		
4	990-11050-201	SCREW,MX20	2		D		
5	992-10050-012	WASHER,S,5	2		A		
6	992-00050-011	WASHER,SMALL,5	2		C		
7	017-06500-200	GASKET,CYLINDER	1		B		
8	041-00601-210	RING,PISTON	1		A		
9	031-06500-200	PISTON	1		B		
10	037-06500-200	PIN,PISTON	1		C		
11	039-01620-200	CIRCLIP,PISTON PIN	2		A		
12	046-06500-801	CRANKSHAFT	1		D		
13	999-62081-225	BEARING,NEEDLE,F-810	1		C		
21	072-06500-90	CRANKCASE ASS'Y	1		D		Includes bearings, seals & gasket.
22	090-06500-200	GASKET,CRANKCASE	1		C		
23	999-66122-269	SEAL,OIL,#1227	2		D		
24	999-61600-100	BEARING,BALL,#6001	2		B		
25	330-00200-210	SHIM,12.2X19X.10	1		D		
25	330-00200-220	SHIM,12.2X19X.15	1		D		Shims are "as needed" to obtain correct c/s side clearance.
25	330-00200-230	SHIM,12.2X19X.20	1		D		
25	330-00200-240	SHIM,12.2X19X.30	1		D		
26	599-00601-200	CUSHION	1		D		
27	167-21523-800	COIL,IGNITION	1		C		
28	994-16040-226	SCREW,WS,4X22	2		D		
29	992-10050-012	WASHER,S,5	3		A		
30	990-11050-301	SCREW,5X30	3		C		
31	155-21523-800	ROTOR,MAGNETO	1		D		
32	992-01080-011	WASHER,8	1		A		
33	992-10080-012	WASHER,S,8	1		B		
34	991-01080-011	NUT,8	1		B		
35	100-02100-200	BOLT,STUD,6X22	2		C		
36	250-06500-200	TUBE,INSULATOR	1		D		

* Indicates the part is included in a kit or assembly and is not available individually. Q=Quan. used C=Interchangeability S=Stocking code: A=Fast moving B=Med. fast C=Med. move D=Slow move E=N.L.A. F=Superseded or replaced by a new part

FIG.2 ENGINE COMPONENTS

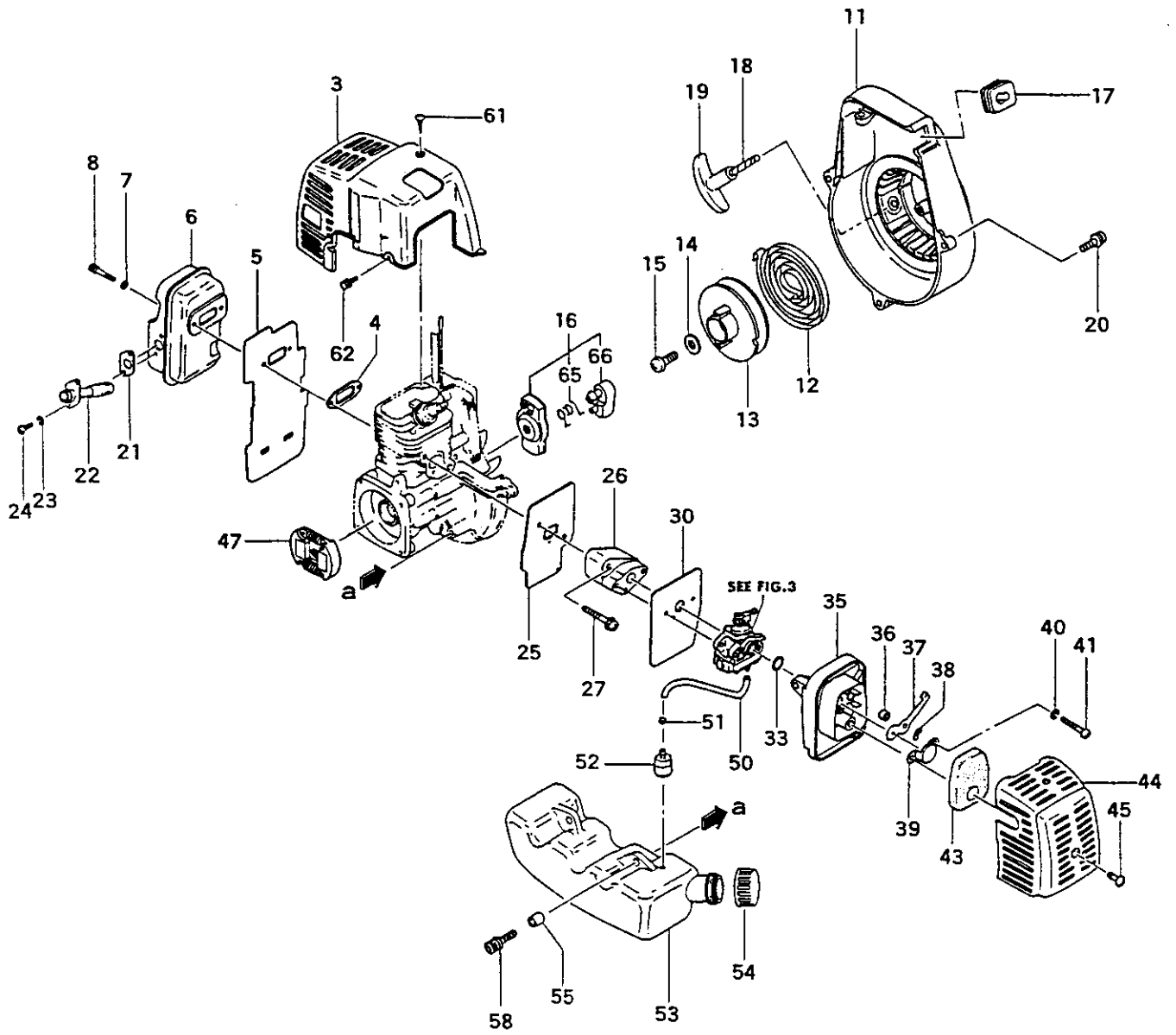

FIGURE 2

THT-240 PARTS LISTING

REF.	PART NO.	PART DESCRIPTION	Q	C	S	SERIAL NO	REMARKS
3	738-06500-20	PROTECTOR,MUFFLER	1		C		
4	737-06500-200	GASKET,MUFFLER	1		C		
5	133-06500-200	SHIELD,HEAT	1		C		
6	706-06500-800	MUFFLER	1		D		
7	992-01050-011	WASHER,5	2		A		
8	990-51050-503	BOLT,HEX,5X50	2		C		
11	112-06500-80	CASE,FAN	1		C		
12	780-06097-200	SPRING,RECOIL	1		A		
13	774-06097-200	PULLEY,STARTER	1		B		
14	801-06091-200	WASHER,ROPE REEL	1		C		
15	839-00025-200	SCREW,SET	1		D		
16	798-06500-900	PULLEY,STARTER,ASS'Y	1		C		
17	203-0604A-202	GROMMET	1		C		
18	783-06097-200	ROPE,STARTER	1		C		
19	785-06410-200	HANDLE,STARTER	1		C		
20	994-15040-162	SCREW,PS,4X16	3		C		
21	751-06500-200	GASKET,MUFFLER	1		C		
22	721-06500-800	PIPE,TAIL	1		C		
23	992-10040-012	WASHER,S,4	2		B		
24	990-11040-081	SCREW,4X8	2		C		
25	403-06500-200	GASKET,INTAKE	1		B		
26	404-06500-800	INSULATOR,CARBURETOR	1		C		
27	994-16050-252	SCREW,5X25WS	2		D		
30	402-06500-200	GASKET,CARBURETOR	1		B		
33	999-67015-000	O-RING,P15	1		C		
35	423-06500-80	BODY,CLEANER	1		C		
36	470-06500-200	COLLAR	2		D		
37	528-06500-200	VALVE,CHOKE	1		D		
38	992-04080-030	WASHER,8	1		C		
39	476-01700-200	BOARD,BLOW OVER CHECK	1		D		
40	992-10050-012	WASHER,S,5	2		A		
41	990-11050-602	SCREW,5X60	2		C		
43	446-06500-20	ELEMENT,CLEANER	1		A		
44	452-06500-200	COVER,CLEANER	1		C		
45	380-0637C-200	BOLT,CLEANER	1		B		
47	277-0635M-800	CLUTCH	1		B		
50	223-06500-90	PIPE,FUEL,ASS'Y	1		C		See PI-3069
51	680-00731-201	CLIP	1		B		
52	675-0641E-900	FILTER,FUEL	1		A		

* Indicates the part is included in a kit or assembly and is not available individually. Q=Quan. used
C=Interchangeability S=Stocking code: A=Fast moving B=Med. fast C=Med. move D=Slow move
E=N.L.A. F=Superceded or replaced by a new part

FIGURE 2 cont.

THT-240 PARTS LISTING

REF.	PART NO.	PART DESCRIPTION	Q	C	S	SERIAL NO.	REMARKS
53	591-06500-20	TANK,FUEL	1		C		
54	595-0650A-90	CAP,TANK	1		A		
55	659-00801-200	COLLAR,TANK HOLDING METAL	2		C		
58	994-63050-185	BOLT,HEX 5X18PS	2		D		
61	990-72045-164	SCREW,TAPPING,4.5X16	1		C		
62	994-25040-128	BOLT,PS,4X12	2		C		
65	790-06097-200	SPRING,STARTER PAWL	1		C		
66	788-06500-20	PAWL,STARTER	1		C		

* Indicates the part is included in a kit or assembly and is not available individually. Q=Quantity used C=Interchangeability S=Stocking code: A=Fast moving B=Med. fast C=Med. move D=Slow move E=N.L.A. F=Superseded or replaced by a new part

FIG.3 CARBURETOR

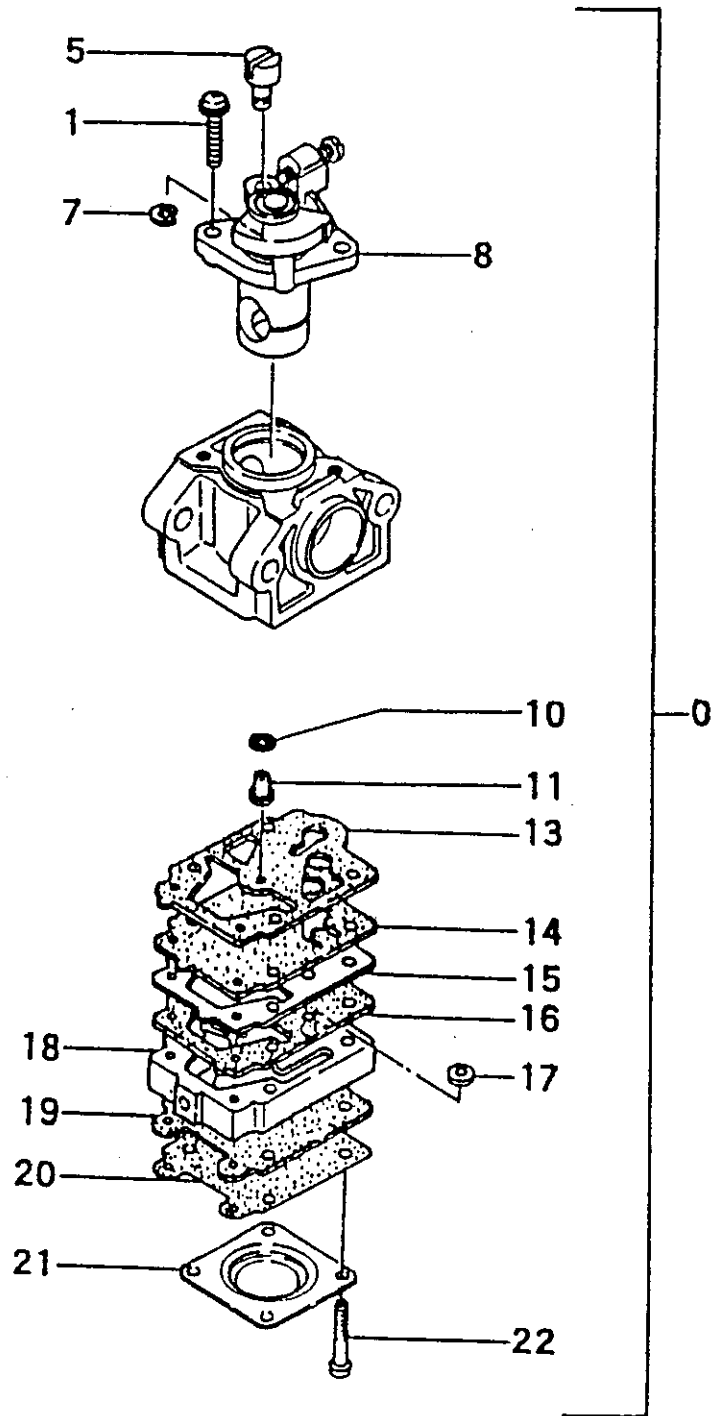

FIGURE 3

THT-240 PARTS LISTING

REF.	PART NO.	PART DESCRIPTION	Q	C	S	SERIAL NO.	REMARKS
0	455-25145-900	CARBURETOR,ASS'Y	1		C	~R222951	
0	455-25182-90	CARBURETOR,ASS'Y	1		C	R222952~	
1	548-25140-200	SCREW,THROTTLE SET	2		D		
5	539-25120-200	SWIVEL	1		D		
7	489-25100-200	RING,STOP	1		D		
08	488-25145-800	VALVE,THROTTLE	1		D		
10	~~~	*O-RING	1				
11	599-2000W-410	JET,MAIN,#41	1		D		* Contained in Carb Repair Kit 650-25140-900 (Not available individually)
13	~~~	*GASKET,PUMP	1				
14	~~~	*DIAPHRAGM,PUMP	1				
15	523-25100-201	PLATE,PUMP	1		C		
16	522-25100-200	PLATE,CIRCUIT	1		C		
17	~~~	*SCREEN,INLET	1				
18	575-25140-800	BODY,PUMP	1		D	~R222951	
18	575-25182-80	BODY,PUMP	1		C	R222952~	
19	~~~	*GASKET,DIAPHRAGM	1				
20	~~~	*DIAPHRAGM,METERING	1				
21	476-25004-200	COVER,DIAPHRAGM	1		D		
22	548-25101-200	SCREW,SET	4		D		

* Indicates the part is included in a kit or assembly and is not available individually. Q=Quan. used
 C=Interchangeability S=Stocking code: A-Fast moving B=Med. fast C=Med. move D=Slow move
 E=N.L.A. F=Supersceded or replaced by a new part

FIG.4 GEAR CASE & CUTTER

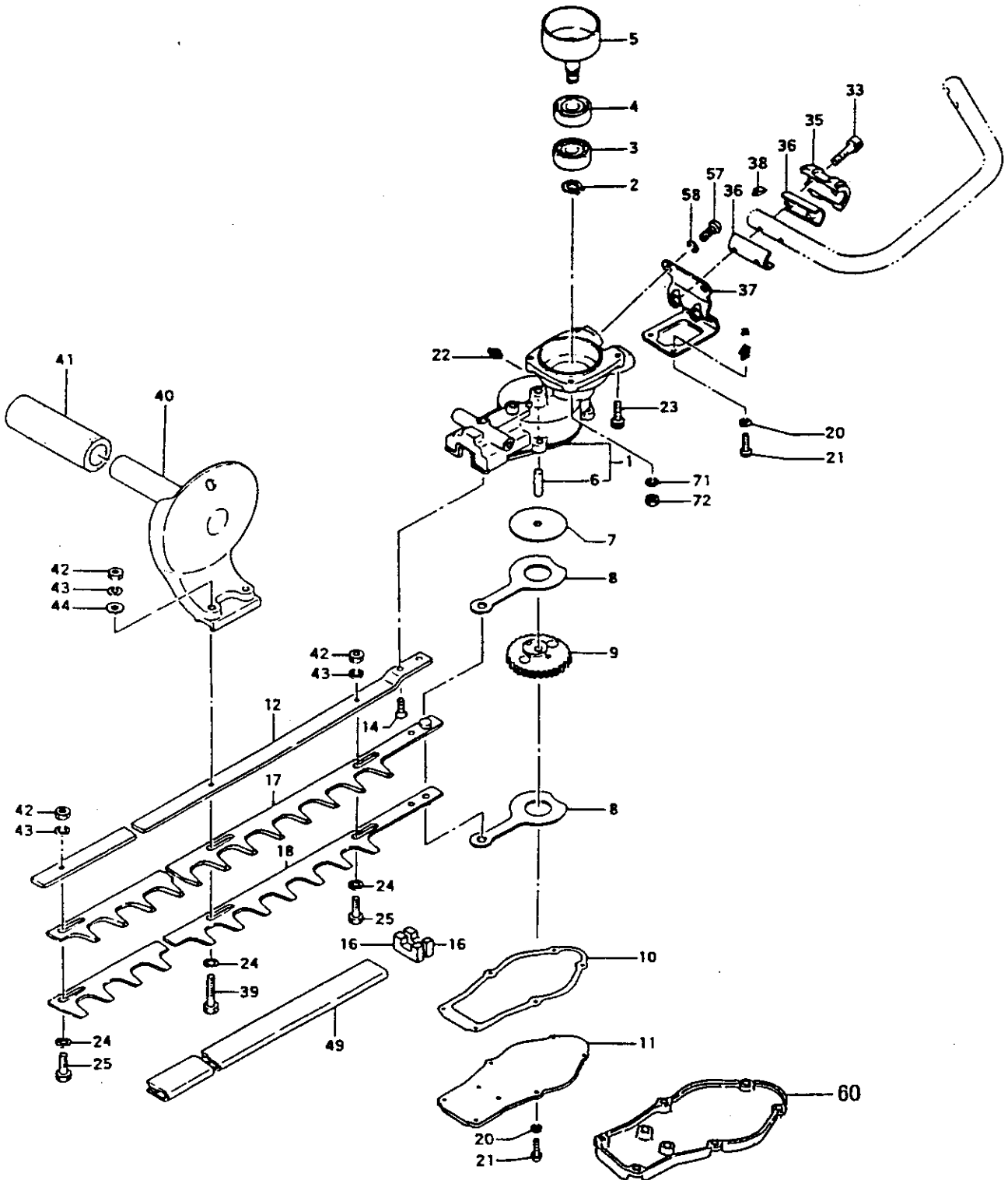

FIGURE 4

THT-240 PARTS LISTING

REF.	PART NO.	PART DESCRIPTION	Q	C	S	SERIAL NO	REMARKS
1	300-3318B-80	CASE,GEAR	1		D		
2	993-50015-002	RING,STOP,C-15 EX	1		C		
3	999-61600-200	BEARING,BALL,#6002	1		B		
4	999-61600-202	BEARING,BALL,#6002Z	1		C		
5	288-33180-80	DRUM,CLUTCH	1		D		
6	305-33160-200	SHAFT,GEAR	1		D		
7	075-33160-200	PLATE,GUIDE	1		D		
8	101-33160-22	ROD,CAM	2		C		
9	307-33180-20	GEAR,2	1		D		
10	303-33160-200	GASKET,GEARCASE	1		B		
11	630-33160-200	COVER,GEAR CASE	1		C		
12	122-33180-20	GUIDE,CUTTER,THT-240	1		D		
14	990-52060-165	BOLT,HEX,6X16	2		B		
16	085-33160-200	SEAL,GREASE A	2		B		
17	CB--24B	BLADE,CUTTER,THT-240	1		D		
18	CB--24A	BLADE,CUTTER,THT-240	1		D		
20	992-10040-062	WASHER,SPRING 4	8		A		
21	990-51040-103	BOLT,HEX.HOLE,4X10	8		A		
22	300-32250-801	NIPPLE,GREASE	1		D		
23	990-51060-143	BOLT,HEX,6X14	2		D		
24	129-33202-201	WASHER,7	5		A		
25	124-33202-206	BOLT,BLADE,A	4		A		
33	990-51050-353	BOLT,HEX.HOLE,5X35	2		C		
35	057-33234-20	HOLDER,HANDLE	1		D		
36	060-33250-201	DAMPER,RUBBER	2		D		
37	058-33180-80	BRACKET,HANDLE	1		D		
38	176-0062W-201	TERMINAL,GROUNDING	1		C		
39	125-33202-205	BOLT,CUTTER FIXING B	1		B		
40	051-33210-82	HANDLE,B	1		C		
41	503-37500-200	GRIP,HANDLE	1		C		
42	123-33202-200	NUT,CUTTER FIXING	5		A		
43	992-10060-012	WASHER,S,6	5		A		
44	992-01060-011	WASHER,6	1		A		
49	138-33215-202	COVER,CUTTER,30"	1		C		
57	990-11050-121	SCREW,5X12	2		A		
58	992-10050-062	WASHER,S,5	2		D		
60	301-33160-00	GEAR CASE COVER SET	1		B	R240001~	Will fit all THT-240 units
71	992-10060-012	WASHER,S,6	2		A		
72	991-01060-011	NUT,6	2		A		

* Indicates the part is included in a kit or assembly and is not available individually. Q=Quan. used
C=Interchangeability S=Stocking code: A=Fast moving B=Med. fast C=Med. move D=Slow move
E=N.L.A. F=Superseded or replaced by a new part

FIG.5 HANDLE

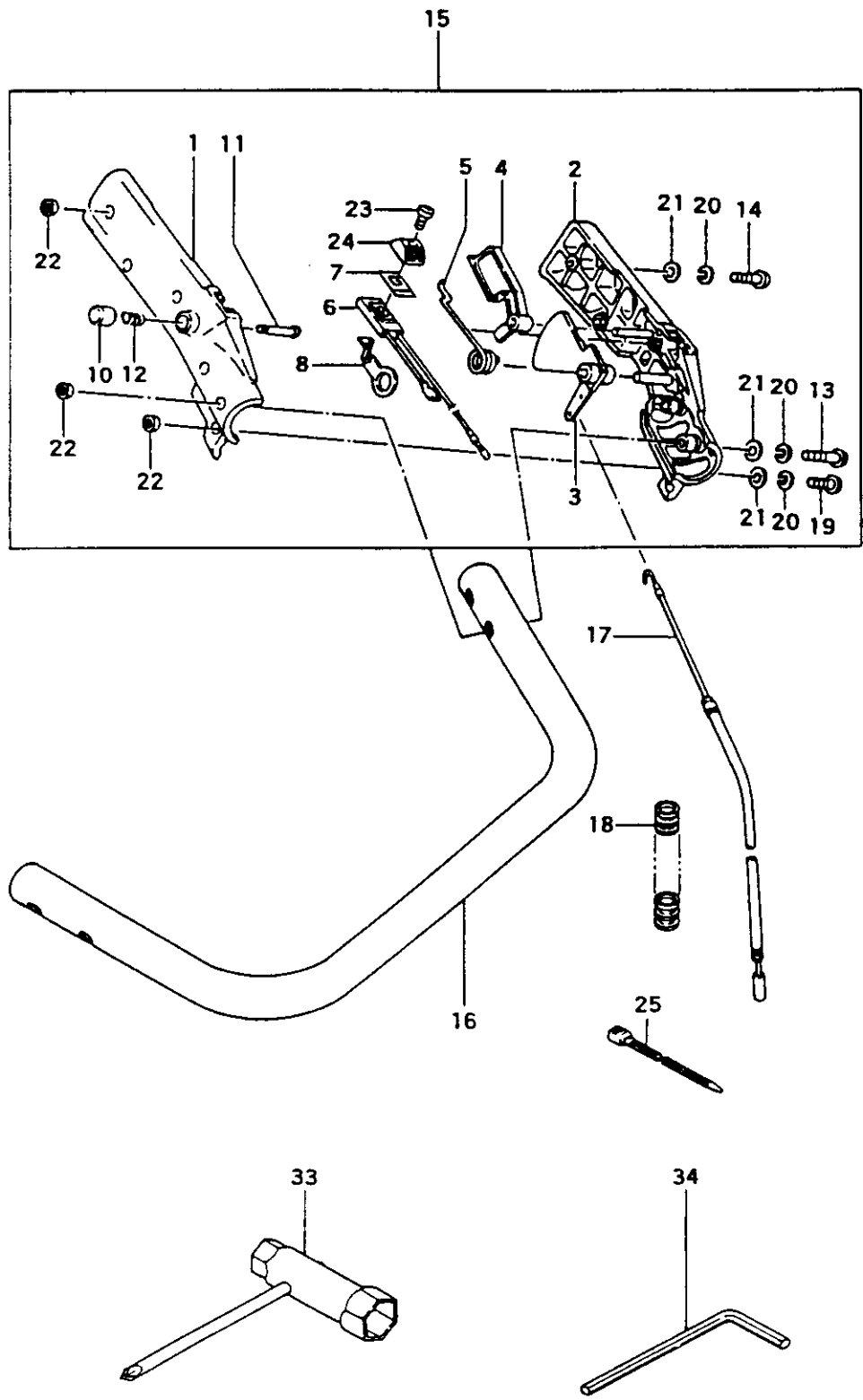

FIGURE 5

THT-240 PARTS LISTING

REF.	PART NO.	PART DESCRIPTION	Q	C	S	SERIAL NO.	REMARKS
1	053-33231-220	GRIP,HANDLE A	1		D		
2	054-33231-222	GRIP,HANDLE B	1		D		
3	230-33210-201	LEVER,THROTTLE	1		D		
4	231-33210-200	LEVER,SAFETY	1		D		
5	061-32600-201	SPRING,THROTTLE LEVER	1		D		
6	170-33180-80	SWITCH,STOP	1		D		
7	925-32530-200	DECAL,STOP BUTTON	1		C		
8	319-37900-201	TERMINAL,GROUNDING	1		D		
10	725-32600-202	CAP,PUSH PIN	1		C		
11	064-33225-200	PIN,PUSH	1		D		
12	066-32300-201	SPRING,STOPPER	1		D		
13	990-11040-301	SCREW,4X30	2		D		
14	990-11040-251	SCREW,4X25	1		C		
15	055-33180-90	GRIP,HANDLE ASS'Y	1		D		
16	050-33180-80	HANDLE,A	1		D		
17	885-0650J-80	WIRE,THROTTLE	1		D		
18	164-10014-400	TUBE,PROTECTION	1		D		
19	990-11040-141	SCREW,4X14	3		B		
20	992-10040-012	WASHER,S,4	6		B		
21	992-00040-011	WASHER,4	6		B		
22	991-78040-010	NUT,LOCK 4	6		C		
23	990-11030-101	SCREW,3X10	1		B		
24	258-11650-20	BUTTON,STOP	1		C		
25	198-33130-200	CLAMP,CORD	1		D		
33	036-29331-501	SPANNER,COMBI	1		D		
34	813-20000-200	WRENCH,HEX,4	1		D		

* Indicates the part is included in a kit or assembly and is not available individually. Q=Quan. used C=Interchangeability S=Stocking code: A=Fast moving B=Med. fast C=Med. move D=Slow move E=N.L.A. F=Superceded or replaced by a new part

FIG.6 MARKS

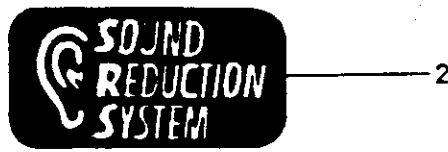
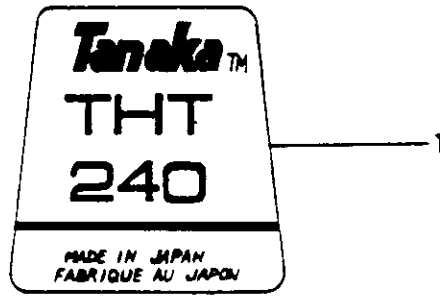

FIGURE 6

THT-240 PARTS LISTING

REF.	PART NO.	PART DESCRIPTION	Q	C	S	SERIAL NO.	REMARKS
1	906-0650N-20	DECAL,THT-240	1		D		
2	911-06500-200	DECAL,SRS	1		D		
3	950-37900-200	DECAL,PRO-FORCE A	1		C		
4	951-37900-200	DECAL,PRO-FORCE	1		D		