

# MR. COFFEE®

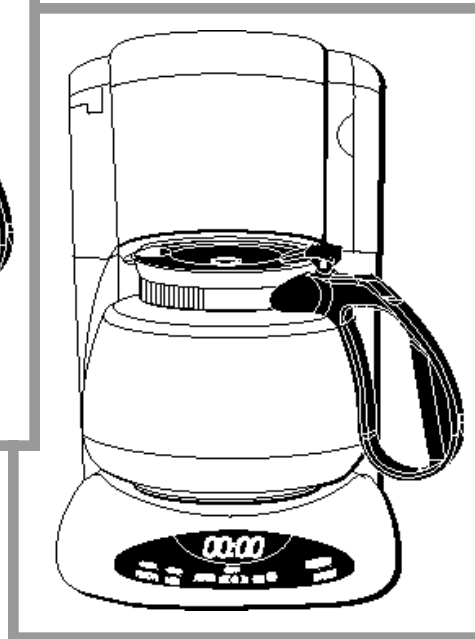

MODEL NL12, NL12D/WHITE  
NL13, NL13D/BLACK



MODEL NLX20, NLX20D/WHITE  
NLX23, NLX23D/BLACK

MODELS NL12, NL12D, NL13, NL13D  
NLX20, NLX20D, NLX23, NLX23D

Instruction Manual  
MR. COFFEE® COFFEEMAKER

# IMPORTANT SAFEGUARDS

When using electrical appliances, basic safety precautions should always be followed to reduce the risk of fire, electric shock and/or injury to persons, including the following:

1. **READ ALL INSTRUCTIONS BEFORE USING THE MACHINE.**
2. Do not touch hot surfaces. Use handles or knobs.
3. To protect against electric shock, do not immerse cord, plugs or machine in water or other liquids.
4. Close adult supervision is necessary when this appliance is used by or near children.
5. Unplug from outlet when Coffee Maker is not in use and before cleaning.  
Allow to cool before putting on or taking off parts and before cleaning the appliance.
6. Do not operate any appliance with a damaged cord or plug or after the appliance malfunctions or has been damaged in any manner. Return this appliance only to the nearest Authorized Service Center for examination, repair or adjustment.
7. The use of accessory attachments not recommended by Sunbeam may cause hazards or injuries.
8. Do not use outdoors.
9. Do not let cord hang over edge of table or countertop or to touch hot surfaces.
10. Do not place this appliance on or near a hot gas or electric burner or in a heated oven.
11. To disconnect, remove plug from wall outlet.
12. Do not use appliance for other than its intended use.
13. Use on a hard, flat level surface only, to avoid interruption of air flow underneath the appliance.
14. **DECANTER USE AND CARE**  
Breakage may occur if the following instructions are not followed:  
Use only decanters specifically designed for MR. COFFEE® models.
  - a. This decanter is designed for use with your MR. COFFEE® Coffee Maker and therefore must never be used on a rangetop or in any oven, INCLUDING A MICROWAVE.
  - b. Do not set a hot decanter on a wet or cold surface.
  - c. Do not use a cracked decanter or a decanter with a loose or weakened handle.
  - d. Do not clean the decanter with cleansers, steel wool pads or other abrasive materials.
  - e. Discard decanter immediately if it is ever boiled dry.
  - f. Avoid sharp blows, scratches or rough handling.
15. **WARNING: To reduce the risk of fire or electric shock, do not remove any service covers. No user serviceable parts inside. Repair should be done by authorized personnel only. Opening the bottom service cover will void the warranty.**

**THIS UNIT IS FOR HOUSEHOLD USE ONLY**

## SPECIAL CORD SET INSTRUCTIONS

1. A short power supply cord is provided to reduce the hazards resulting from becoming entangled in or tripping over a longer cord.
2. An extension cord may be purchased and used if care is exercised in its use.
3. If an extension cord is used, the marked electrical rating of the extension cord must be at least 10 amps and 120 volts. The resulting extended cord must be arranged so that it will not drape over the countertop or tabletop where it can be pulled on by children or tripped over accidentally.

**\*This appliance has a polarized plug (*one blade is wider than the other*). To reduce the risk of electric shock, this plug will fit in a polarized outlet only one way. If the plug does not fit fully in the outlet, reverse the plug. If it still does not fit, contact a qualified electrician. Do not modify the plug in any way.**

### IF SERVICE IS REQUIRED, DO NOT RETURN TO YOUR STORE

For Service, call 1-800 MR COFFEE (1-800-672-6333)  
8:30 A.M. to 5:00 P.M., Eastern Standard Time, Monday through Friday

**TO ASSIST US IN SERVING YOU, PLEASE HAVE THE MODEL NUMBER  
(NL12, NL12D, NL13, NL13D, NLX20, NLX20D, NLX23 OR NLX23D)  
AND DATE OF PURCHASE AVAILABLE.**

All repairs must be made by Sunbeam or by an *Authorized* MR. COFFEE<sup>SM</sup> Service Center.  
Please call us for assistance or for the location of the nearest Authorized MR. COFFEE<sup>SM</sup> Service Center.

**PLEASE DO NOT RETURN THIS APPLIANCE TO YOUR STORE.**

**We welcome your questions, comments or suggestions.**

Please include your complete name, address and telephone number.

Consumer Affairs Department  
MR. COFFEE®  
A Product of Sunbeam Corporation  
P.O. Box 948389  
Maitland, Florida 32794-8389

**1-800 MR COFFEE (1-800-672-6333)**

## SAVE THESE INSTRUCTIONS

## INTRODUCTION

**CONGRATULATIONS!** You are the owner of a MR. COFFEE® Coffee Maker.

Please read **all** of the instructions in this manual carefully before you begin to use this appliance. Proper care and maintenance will ensure the long life of this appliance and its trouble-free operation. Save these instructions and refer to them often for cleaning and care tips.

## DIAGRAM OF PARTS



FOR BETTER TASTING  
TEA AND COFFEE,  
USE 8-12 CUP  
MR. COFFEE  
BRAND FILTERS.

MR. COFFEE  
REPLACEMENT DECANTER: ND13

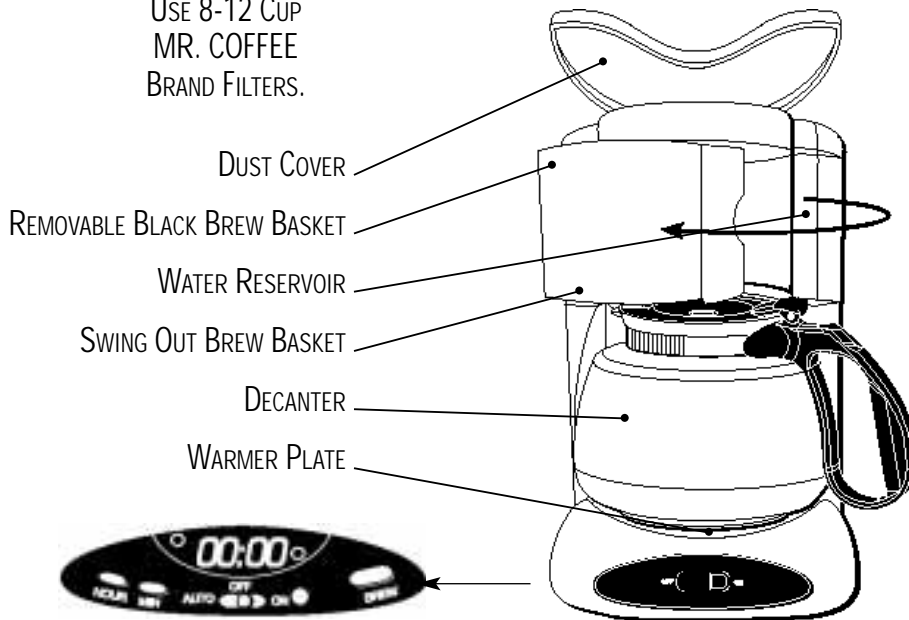

MODELS  
NLX20, NLX20D/WHITE,  
NLX23, NLX23D/BLACK

MODELS  
NL12, NL12D/WHITE,  
NL13, NL13D/BLACK

## OPERATION AND USE

### BEFORE FIRST USE

Before using your Coffee Maker for the first time, wash decanter/lid and removable brew basket (*black*) using a mild, non-abrasive detergent and water. Rinse each thoroughly. Follow steps 4-6 (*Brewing Coffee*) using water, to clean the inside.

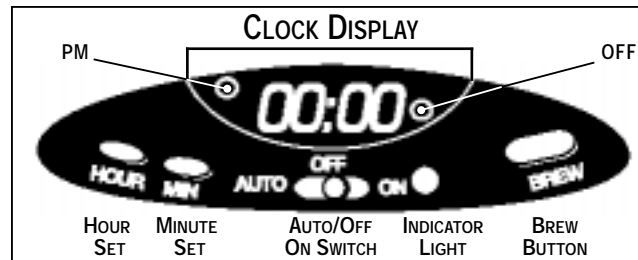

### SETTING CLOCK AND TIMER (NLX20, NLX20D, NLX23, NLX23D)

**NOTE:** You do not have to set your clock before the Coffee Maker will operate. Plug in the power cord, slide the control lever to the "on" position. The green light will illuminate.

#### SETTING THE CLOCK

1. Turn the AUTO/OFF/ON switch to "OFF."
2. Plug the power cord into your electrical outlet. The clock display will flash until you set the time.
3. Alternately press and hold the "HOUR" and "MINUTE" buttons until you reach the current time. The "PM" indicator light in the display will illuminate to indicate PM time.

#### PRESETTING THE BREWING TIME

1. Press and hold the "BREW" button while setting the desired brew time with the "HOUR" and "MINUTE" buttons. The "PM" indicator light in the display will illuminate to indicate PM time.

#### BREWING AUTOMATICALLY AT THE PRESET TIME

1. Follow steps 1-5 in the "brewing" section.
2. Turn the control switch to "OFF" and then to "AUTO."
3. Brewing will begin at the time you have preset. The coffee will remain hot in the decanter for 2 hours. To keep your coffee hot for an additional 2 hours, turn the switch from "AUTO" to "ON."

#### IMPORTANT: RESETTNG AUTO BREW AT THE PRE-SET TIME

The programmable timer will not automatically brew the next day if left in the "AUTO" position after its last use. This is a safety feature. If the "OFF" indicator light in the lower right hand corner of the clock display is illuminated, reset "AUTO BREW" by turning the control switch to "OFF," then to "AUTO."

## BREWING

If the clock display is flashing, refer to section (*setting the clock*) before continuing.

1. Open the swing-out brew basket to your left. Insert a MR. COFFEE filter into the removable black inner brew basket.
2. Add desired amount of coffee, referring to the Coffee Measurement Chart. Shake lightly to level coffee.
3. Be sure the paper filter is centered before closing the brew basket.
4. Fill the decanter with cold water to desired capacity as marked on the side of the decanter. (1 cup = 5 oz).
5. Pour the water into the water reservoir. **NOTE:** For easy and accurate filling, refer to cup markings inside the reservoir. Place the empty decanter onto the warmer plate.
6. Turn your Coffee Maker switch to "ON". When the coffee stops flowing, the brewing cycle is complete.
7. Carefully remove the black inner brew basket and discard the used grounds and filter. Rinse the black brew basket and replace. **NOTE:** Remove decanter from the warming plate before opening the swivel basket. This will prevent the drip stop valve from catching on the decanter lid.
8. To make another pot of coffee, repeat steps 1-7.
9. Turn your Coffee Maker off when the decanter is empty. To turn off, slide the control switch to the "OFF" position.

**WARNING:** To avoid risk of personal injury or damage to property as a result of overflow, be sure the decanter is squarely centered under the brew basket during the brewing cycle. Brewed coffee and grounds, both in brew basket and decanter, are very hot. Handle with care to avoid scalding. If brew basket overflows, or if brew basket fails to drain into decanter during brew cycle, do not open or handle basket. Unplug Coffee Maker and wait for contents to cool before handling.

## COFFEE MEASUREMENT CHART

*FOR BEST RESULTS, USE DRIP GRIND RECOMMENDED FOR AUTOMATIC DRIP COFFEEMAKERS.*

2 LEVEL TBSP. = 1 LEVEL SCOOP      1 CUP = 5 OZ. BREWED COFFEE

Use more or less coffee to suit taste.

<u>CUPS</u>	<u>GROUND COFFEE</u>
12	11 Tbsp. <i>or</i> 5-1/2 Scoops
10	9 Tbsp. <i>or</i> 4-1/2 Scoops
8	7 Tbsp. <i>or</i> 3-1/2 Scoops
6	6 Tbsp. <i>or</i> 3 Scoops
4	5 Tbsp. <i>or</i> 2-1/2 Scoops
2	3 Tbsp. <i>or</i> 1-1/2 Scoops

## **AUTOMATIC BREWING PAUSE N' SERVE – DRIP STOP VALVE**

Our Brewing Pause N' Serve feature allows you up to 30 seconds to pour a cup while the coffee is still brewing. It also prevents any remaining coffee in the brew basket from dripping onto the warmer plate once brew cycle is complete.

**WARNING:** To prevent injury from hot overflow, replace decanter within 30 seconds if removed during brewing. If the decanter is not replaced within 30 seconds, the filter basket will fill with water and overflow.

## **AUTOMATIC SHUT-OFF** (*Models NLX20, NLX20D, NLX23, NLX23D Only*)

Your Coffee Maker will keep your coffee hot for 2 hours, then automatically shut off. To keep your coffee hot for an additional 2 hours, slide the control switch to "OFF" and then to "ON." When your decanter is empty, turn Coffee Maker off by turning the switch to "OFF."

## **CLEANING**

Your Coffee Maker must be cleaned when you begin to notice excessive steaming or the brewing time increases considerably. This condition is caused by a build-up of lime and mineral deposits from your water. If the pumping action stops before all the water has been pumped out of the machine, the appliance requires cleaning.

The frequency of cleaning depends on the hardness of water used. The following table gives a suggested cleaning schedule.

### **SUGGESTED CLEANING INTERVAL**

Type of Water	Cleaning Frequency
Soft Water	Every 80 Brew Cycles
Hard Water	Every 40 Brew Cycles

Your Coffee Maker may be cleaned by using MR. COFFEE Cleaner or vinegar. MR. COFFEE Cleaner is available at many retail stores or by calling the MR. COFFEE Consumer Affairs Department at 1-800-MR COFFEE (1-800-672-6333).

## **USING MR. COFFEE CLEANER**

Read caution statement on side panel of box before use.

## CLEANING

### USING VINEGAR

1. Pour 1 quart of undiluted white household vinegar into Coffee Maker.
2. Place a paper filter into the black brew basket and close the swivel basket.
3. Place the empty decanter on the warming plate. Turn the Coffee Maker to "ON." When three cups have flowed through, turn the Coffee Maker to "OFF." Let stand for 1/2 hour.
4. After 1/2 hour, pour vinegar back into the Coffee Maker. Place the empty decanter on the warming plate.
5. Turn Coffee Maker to "ON" and let all of the vinegar run to completion.
6. Discard the vinegar and paper filter.
7. To flush out all traces of vinegar, pour decanter full of tap water into Coffee Maker, turn switch to "ON." Allow it to cycle through.
8. Discard water and turn Coffee Maker off. Repeat Steps 7 through 8.

### DECANTER

Decanter and Lid Are Top-Rack Dishwasher Safe

Hard water can leave a whitish mineral deposit inside the decanter. Coffee and tea discolor these deposits, sometimes leaving a brownish stain inside the decanter. To remove these stains, follow these easy steps.

1. Use a solution of equal parts white vinegar and hot water.
2. Let solution stand in decanter for about 20 minutes. Discard.
3. Wash and rinse decanter thoroughly using soft cloth. Do not use harsh abrasive cleaners. These may cause scratches and can lead to breakage.



## NOTES

## NOTES

## NOTES

## 1-YEAR LIMITED WARRANTY

Sunbeam warrants to the purchaser that this MR. COFFEE® Coffee Maker (*except for cord set and glass parts*) is free from manufacturer's defects in material and workmanship for a period of one year from the date of original purchase when used in compliance with directions as outlined in the manufacturer's instructions, which will constitute reasonable and necessary maintenance by the purchaser.

In case of manufacturer defects in material or workmanship, Sunbeam agrees to repair (remedy) a defective Coffee Maker without charge. The purchaser's exclusive remedy against Sunbeam shall be for the repair or replacement of a defective MR. COFFEE® product.

All repairs must be made at an *Authorized MR. COFFEE<sup>SM</sup> Service Center*. To locate a MR. COFFEE<sup>SM</sup> Service Center, call 1-800 MR COFFEE (1-800-672-6333). *Sunbeam shall not be responsible for any repairs performed at any facility which is not an Authorized MR. COFFEE<sup>SM</sup> Service Center.*

This warranty gives you specific legal rights, and you may have other rights which vary from state to state. Any implied warranty is limited in duration to the one year provided in this, the only, expressed warranty. Some states do not allow limitations on how long an implied warranty lasts, so the above limitation may not apply to you.

**In no event shall Sunbeam be responsible for incidental or consequential damages**, nor damage due to misuse or the use of any unauthorized attachment; nor damage caused by use of an electrical circuit not specified on the MR. COFFEE® product. Some states do not allow the exclusion or limitation of incidental or consequential damages, so the above limitation or exclusion may not apply to you.

**MR. COFFEE®**  
**A Product of Sunbeam Corporation**  
**Boca Raton, Florida 33431**