

Think GAIA  
For Life and the Earth

**SANYO**

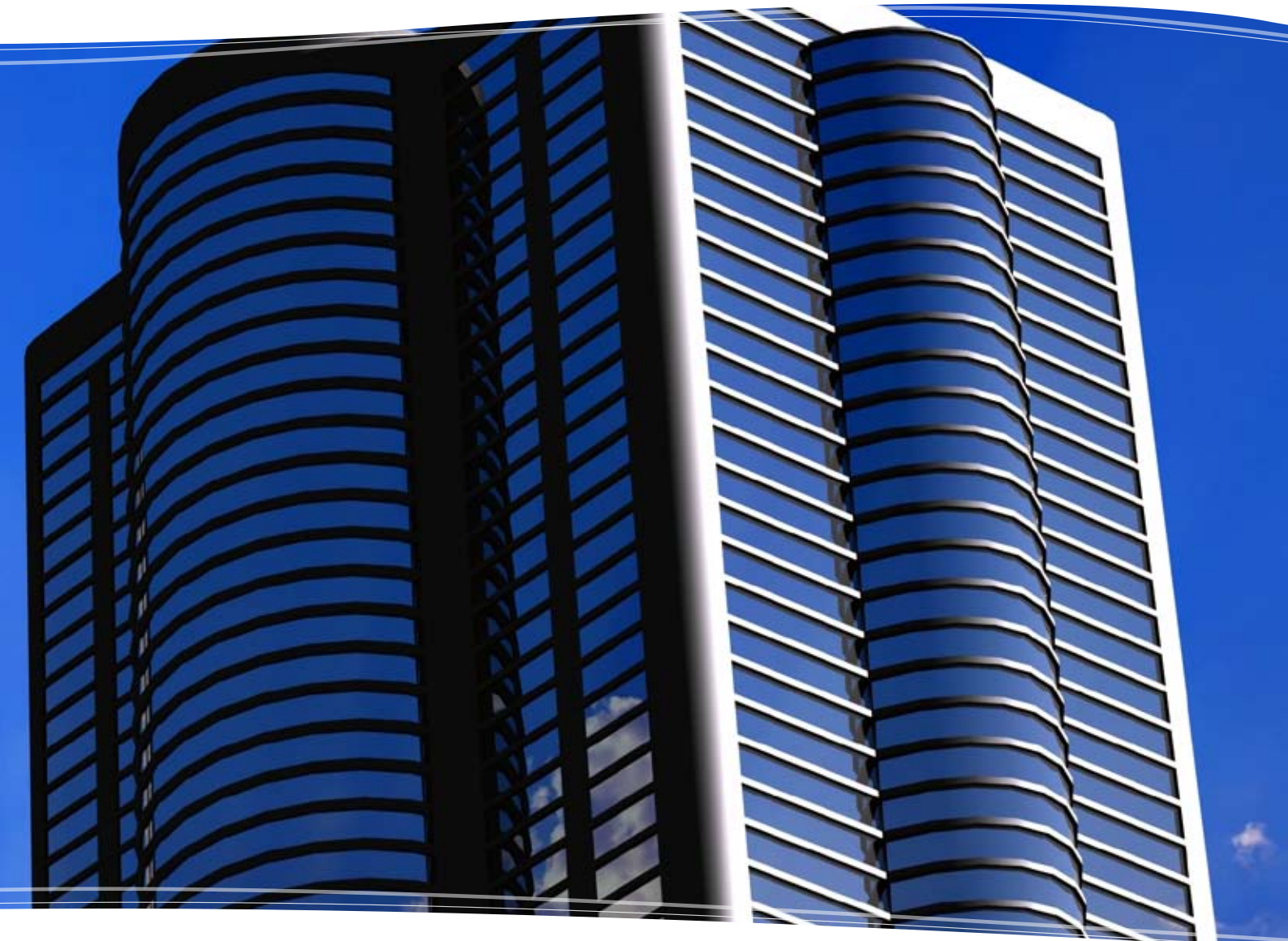

# Gas Driven VRF

## M Series

GAS DRIVEN VRF

ELECTRIC VRF

COMMERCIAL SPLIT SYSTEMS

ROOM AIR CONDITIONERS

HEATING SOLUTIONS



SANYO Air Conditioners. The natural choice.



## Gas Heat Pump M Series - the perfect solution when you're short of power

SANYO has been developing GHP VRF systems since 1980, during which time we have been committed to delivering ground-breaking technology. As a result, the commercial range of GHP VRF systems is leading the industry in the development of efficient and flexible systems, making them the natural choice for commercial projects, especially for those projects where power restrictions apply. As you would expect, all of our gas driven VRF systems have the highest reliability rates in the industry and a leading customer service programme.

The M Series of gas driven VRF systems offers increased efficiency and performance across the range. Now more powerful than ever before, it can connect to up to 48 indoor units.

Improvements include increased part load performance, reduced gas consumption with a Miller-cycle engine and reduced electrical consumption from using DC fan motors.

- Up to 71kW of cooling from a maximum running capacity of 5 AMPs
- Single phase power supply across the range
- The option of natural gas or LPG as its main power source
- Free hot water! A water heat exchanger to connect to domestic hot water systems 13-25 HP (Heat Pump only)
- Option of DX or chilled water for indoor heat exchange
- Option to connect to third party Air Handling Units
- Reduced CO<sub>2</sub> emissions

## SANYO benefits

### High-efficiency operation

13-25 HP models are equipped with a high-performance air exchanger and a newly developed refrigerant heat exchanger for high-efficiency operation, making them one of the most energy-efficient solutions on the market.

### Lowest nitrogen oxide emissions

The GHP VRF systems have the lowest nitrogen oxide emissions, 66% below the standard. In a pioneering development, the SANYO GHP features a brand new lean-burn combustion system that utilises air fuel ratio feedback control to reduce NOx emissions to an all-time low.

### Excellent economy

The SANYO GHP provides quick and powerful cooling/heating and increases delivery of heat into the space by the efficient recovery of heat from the engine cooling water, which is injected into the refrigerant circuit.

In addition, the use of engine waste heat ensures that our gas heat pump air conditioner requires no defrost cycle, therefore providing continuous 100% heating performance in severe weather conditions with an outside air temperature as low as -20°C. During cooling mode the rejected heat from the engine is available for use within a hot water system and can supply up to 25kW of hot water at 75 °C.

### High performance

With its advanced heat exchanger design, this new GHP system offers improved efficiency and reduced running costs, which, coupled with improved engine management systems, have greatly improved the system COP rating.

### New electrical power generator model

The biggest breakthrough in recent GHP technology is the launch of the ECO G Power, which provides 4.0kW of power. That's enough electricity to power 8 computers or other applications.

## GHP features at a glance

- Power generation of up to 4kW on ECO G Power version
- Up to 25kW hot water generation on all 2 pipe heat pump versions
- Chiller module available for water based solutions
- 100% heating performance even at -20°C ambient
- 180% indoor connectability (Single heat pump module)
- Single phase power required through the range

## Power supply problems?

If you are short of electrical power, gas heat pump could be the perfect solution.

- Runs on gas and just needs single phase supply.
- Enables the building's electrical power supply to be used for other critical electrical demands.
- Reduces capital cost to upgrade power substations to run heating and cooling systems.
- Reduces power loadings within a building especially during peak periods.
- Electricity supply freed up for other uses such as IT servers, commercial refrigeration, manufacturing, lighting etc.

The application principle of Variable Refrigerant Flow (VRF) systems for projects with multiple indoor unit is now very much an integral element of the UK air conditioning market place.

A GHP is no different in principle, however, developed by SANYO in 1980 the GHP outdoor unit is fitted with a combustion engine, powered by Natural gas or LPG, to drive the refrigerant compressor.

Variable capacity is achieved via the engine speed being altered up and down just as an inverter compressor speed is controlled in the electric VRF equivalent. The GHP therefore is an ideal solution where electrical power is at a premium (or no 3 phase available) however it also boasts a number of additional benefits/functions that are not available on an electric equivalent.

## High efficiency heat exchanger

The 'M' series GHP continues to use a 'hybrid' heat exchanger for improved efficiency. By interlacing the refrigerant coil with the radiator carrying the coolant from the engine, the condensing capacity and radiator performance is balanced to an optimum level. This combination ensures the cooling efficiency drop in cold ambient is kept to a minimum, heating performance is down to -20°C and maintain a high COP.

## Higher engine efficiency

By utilising a Miller-Cycle engine, the compression stroke is reduced and therefore pumping losses are minimised. As a result the expansion volume ratio increases and the efficiency improves.

Miller cycle: This heat cycle has the characteristic that the closing time for the suction valve in regard to the base engine is late. As a result, the expansion stroke becomes relatively longer in comparison to the compression stroke.

## Refrigerant heat exchanger

By fitting a new plate heat exchanger the engine waste heat is recovered efficiently and reused to improve performance. In addition a proportionate control 3 way change over valve is used for control of the engine cooling water to increase efficiency in heating operation

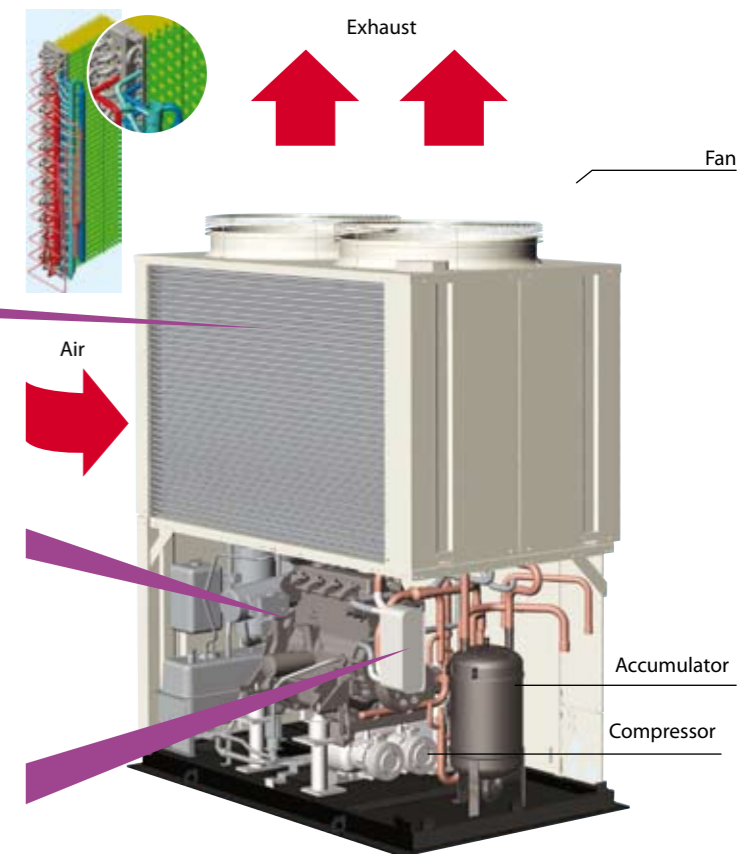

## How a GHP works - High performance and low operating costs by using gas fuel

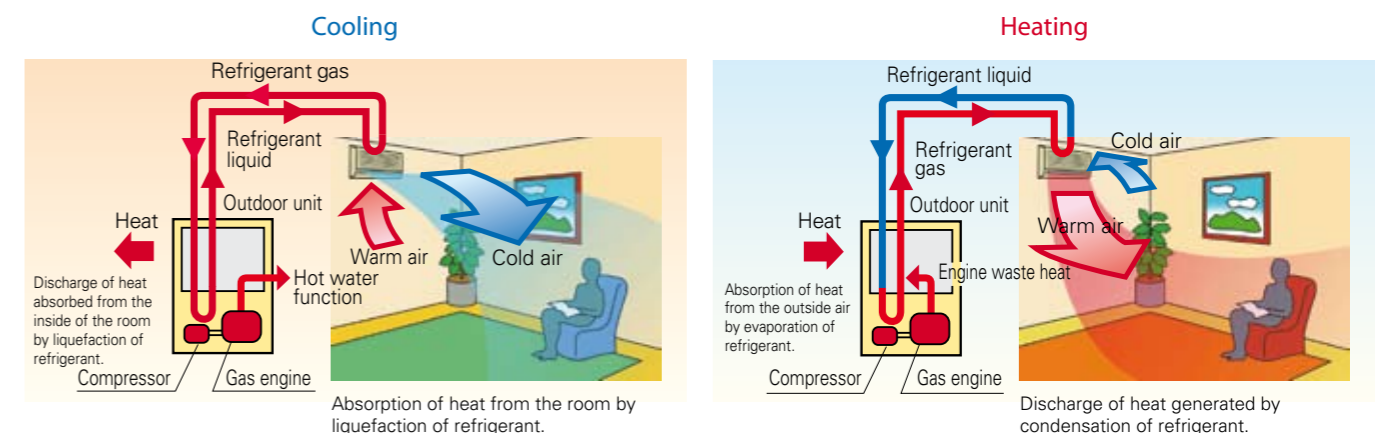

Still the only heat recovery (3 way) GHP system in Europe.

The new M Series ECO G 3 Way offers even more performance and outstanding features when you need simultaneous heating and cooling. Now with increased capacities available from 16HP to 25HP, SANYO offers the greatest choice and flexibility to solve any power problem or site requirement.

- Simultaneous heating and cooling for total control
  - Reduced gas consumption by Miller-cycle engine
  - Reduced electrical power consumption by using DC motors
  - New lightweight design by use of aluminium engine block reduces weight by 110kg
  - Part load efficiencies increased
  - Connectability increased to up to 36 indoor units
  - Now available in 16, 20 and 25HP
  - 200m maximum allowable piping length (L1) (equivalent - refer to technical manual)
  - Diversity ratio 50% - 130%
  - Extended pipe runs (total 500m)
  - Silent mode offers a further 2dB(A) reduction
  - 10,000 run hours between engine service intervals (equivalent to one maintenance every 3.2 years\*)
  - Full heating capacity down to -20°C
  - No defrost cycle
- \* Assuming 3120 running hrs per year - 12 hrs x 5 days x 52 weeks

ECO G 3 Way is ideal for the following types of application:

- Office buildings with a diverse range of room temperatures due to differing load profiles.
- Buildings with computer rooms requiring year round cooling.

### Additional parts

By taking its power supply from the nearest indoor unit, the SANYO solenoid valve (change-over box) does not require any additional fused spur and at only 150mm high can be easily installed within a 200mm void space.

### LPG option

The option of using LPG as a power supply increases flexibility and avoids the problems of potential site restrictions in the future. The purer fuel is also excellent for further reductions in CO<sub>2</sub> emissions - a fact recognised by the government.



Comparison of the start times for heating operation  
Room temperature (°C)

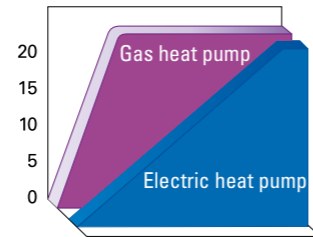

Time axis (in case of the same load)

Comparison of heating capacity  
Heating capacity (%)

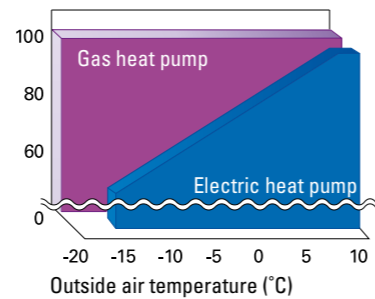

HP	16		20		25	
Model	SGP-EZ150M2G2		SGP-EZ190M2G2		SGP-EZ240M2G2	
Capacity	Cooling	kW	45.0	56.0	71.0	
	Heating	STD kW	50.0	63.0	80.0	
	Heating	Low temp*	53.0	67.0	75.0	
Electricity	Cooling	kW	1.35		1.54	
	Heating	kW	1.01		1.54	
Gas	Cooling	kW	31.6	38.3	60.9	
	Heating	STD kW	36.1	43.0	58.0	
	Heating	LOW kW	47.3	56.4	64.9	
COP	Cooling		1.37	1.41	1.14	
	Heating		1.35	1.43	1.34	
Size	Height	mm	2,248		2,248	
	Width	mm	1,800		1,800	
	Depth	mm	1,000 (+60)		1,000 (+60)	
Weight		kg	845		875	
Starter amperes		A	30		30	
Piping connection	Gas	Inches (mm)	1 1/8 (28.58)		1 1/8 (28.58)	
	Discharge	Inches (mm)	7/8 (22.22)		7/8 (22.22)	
	Liquid	Inches (mm)	3/4 (19.05)		3/4 (19.05)	
Pipe fuel gas			R3/4 (bolt thread)		R3/4 (bolt thread)	
Pipe exhaust drain		mm	ø 25 rubber hose		ø 25 rubber hose	
Operation sound		dB(A)	57	58	62	
Indoor/outdoor capacity ratio			50-180% *1		50-180% *1	
Number of indoor connections			36		36	

\* 1: Low temp condition: Outdoor temperature 2°C.  
Condenser actual pipe connections may vary from above pipe connections shown, please refer to technical manuals for full details. Please refer to tube sizing charts for pipe selections and pipe length parameters.

### Dimensions ECO G 3 Way (16-25HP)

Model Type	150	190	240
① Suction refrigerant pipe	ø28.58		
② Discharge refrigerant pipe	ø22.22   ø25.4		
③ Liquid refrigerant pipe	ø19.05		
④ Exhaust gas drain hose	OD: ø25 Length: 200		
⑤ Inter-unit cable port	ø28		
⑥ Electrical power supply port	ø28		
⑦ Fuel gas port	G: R3/4		
⑧ Condensation drain opening	ø20		
⑨ Rain and condensation outlet	ø20		
⑩ Engine exhaust outlet	ø20		
⑪ Suspension holes	4 - ø20		
⑫ Anchor holes	4 - ø24		
⑬ Segmented display			
⑭ Coolant intake (top)			
⑮ Vent			

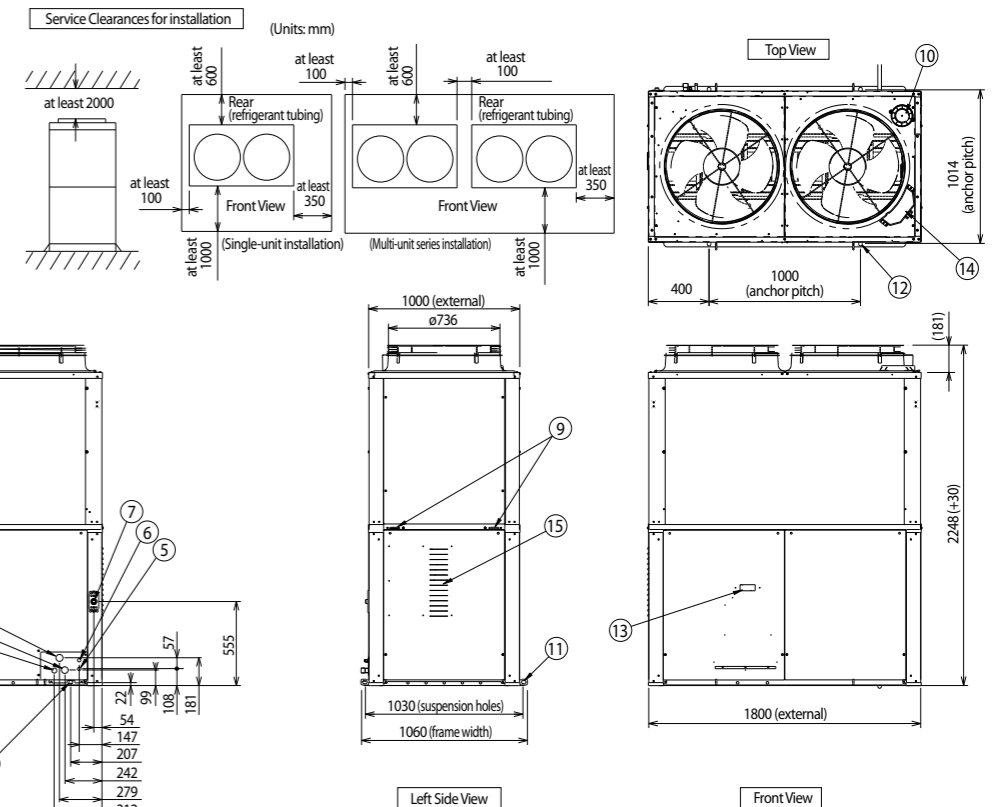

ECO G W-Multi for Heat Pump Applications

The new and improved M Series heat pump (2 Way) not only offers improved performance but also increased flexibility. Now available as multi-systems, many combinations are possible, from 13HP to 50HP, allowing for more power and enabling accurate matching of a system building load. Additional new features include part load engine management and compressor run hour equalisation.

- Reduced gas consumption by Miller-cycle engine
- Reduced electrical power consumption by using DC motors
- New lightweight design by use of aluminium engine block reduces weight by 110kg
- Part load efficiencies increased
- Connectability increased - now up to 48 indoor units
- Multi-systems with combinations from 13HP up to 50HP
- 200m maximum allowable piping length (L1) (equivalent - refer to technical manual)
- Diversity ratio 50-180%
- Extended pipe runs (total 500m)
- Industry leading sound levels
- Silent mode offers a further 2dB(A) reduction
- Chiller option
  - 13HP (25kW cooling - 30kW heating)
  - 25HP (56kW cooling - 67kW heating)
- 10,000 run hours between engine service intervals (equivalent to one maintenance every 3.2 years\*)
- Full heating capacity down to -20°C
- No defrost cycle

\* Assuming 3120 running hrs per year - 12 hrs x 5 days x 52 weeks



Dimensions ECO G W-Multi 2 Way

	Size (mm)		
Model Type	120	150	190 and 240
① Gas refrigerant pipe (Gas tube)	ø25.4	ø28.58	
② Liquid refrigerant pipe (Liquid tube)	ø12.7	ø15.88	
③ Refrigerant balance pipe (Balance tube)	ø9.52		
④ Exhaust gas drain hose	OD: ø25 Length: 200		
⑤ Electrical power supply port	ø28		
⑥ Inter-unit cable port	ø28		
⑦ Fuel gas port	G: R3/4		
⑧ Condensation drain opening	ø20		
⑨ Rain and condensation outlet			
⑩ Engine exhaust outlet			
⑪ Suspension holes	4 - ø20		
⑫ Anchor holes	4 - ø24		
⑬ Segmented display			
⑭ Coolant intake (top)			
⑮ Vent			
⑯ Hot water intake	Rp3/4		
⑰ Hot water outlet	Rp3/4		
⑱ Cable inlet for interlock and the like	ø28		

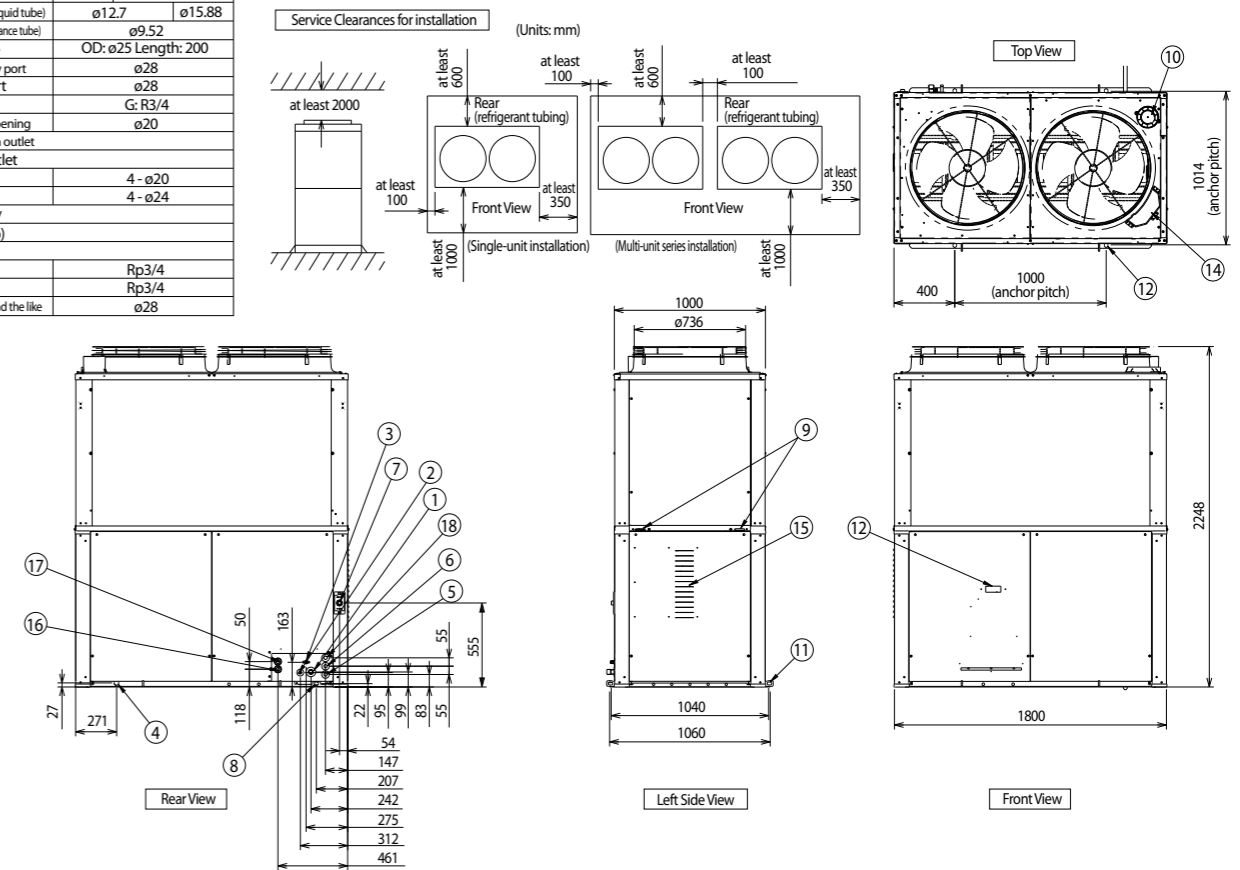

HP		13	16	20	25	26	29	32	33*	36*	40*	45*	50
Model name		SGP-EW120M2G2W	SGP-EW150M2G2W	SGP-EW190M2G2W	SGP-EW240M2G2W	SGP-EW120M2G2W SGP-EW120M2G2W	SGP-EW120M2G2W SGP-EW150M2G2W	SGP-EW150M2G2W SGP-EW190M2G2W	SGP-EW120M2G2W SGP-EW190M2G2W	SGP-EW150M2G2W SGP-EW190M2G2W	SGP-EW190M2G2W SGP-EW240M2G2W	SGP-EW190M2G2W SGP-EW240M2G2W	SGP-EW240M2G2W SGP-EW240M2G2W
Capacity	Cooling	35.50	45.00	56.00		71.00	80.50	90.00	91.50	101.00	112.0	127.00	142.00
	Heating STD	40.00	50.00	63.00		80.00	90.00	100.00	103.00	113.00	126.00	143.00	160.00
	Heating Low temp*1	42.50	53.00	67.00	75.00	85.00	95.50	106.00	109.50	120.00	134.00	142.00	150.00
	Hot water	12.00	16.00	20.00	25.00	24.00	28.00	32.00	32.00	36.00	40.00	45.00	50.00
Electricity	Cooling	0.85		1.35		1.70	2.20	2.70	2.20			2.70	
	Heating		1.01		1.54			2.02				2.55	3.08
Gas consumption	Cooling	24.50	31.60	38.30	60.90	49.00	56.10	63.20	62.80	69.90	76.60	99.20	121.80
	Heating STD	28.10	36.10	43.00	58.00	56.20	64.20	72.20	71.10	79.10	86.00	101.00	116.00
	Heating LOW	36.80	47.30	56.40	64.90	73.60	84.10	94.60	93.20	103.70	112.80	121.30	129.80
	Cooling	1.40	1.37	1.41	1.14	1.40	1.38	1.37	1.41	1.39	1.41	1.25	1.14
COP	Heating	1.37	1.35	1.43	1.34	1.37	1.36	1.35	1.41	1.39	1.43	1.38	1.34
	AVE	1.39	1.36	1.42	1.24	1.39	1.37	1.36	1.41	1.39	1.42	1.31	1.24
	Max COP (inc hot water) Cooling	1.87	1.85	1.92	1.54	1.87	1.86	1.85	1.90	1.89	1.92	1.69	1.54
Size	Height	2,248											
	Width mm	1,800											
	Depth	1,000 (+60) 1,800 + 100 (min distance) + 1,800 (in a straight installation)											
Weight	kg	790		820	850		1,580			1,610	1,640	1,670	1,700
Starter amperes	(A)	30											
Piping connection	Gas	1 1/8 (28.58)											
	Liquid	1/2 (12.7)											
	Balance	5/8 (15.88)											
Pipe fuel gas		3/8 (9.52)											
Pipe exhaust drain		R3/4 (bolt thread) ø25 rubber hose											
Operation sound	dB(A)	57		58	62		60			61	63	65	
Indoor/outdoor capacity ratio		50-180 %											
Number of indoor connections		32		36						48			

\* In case of these combinations EGV190M2G2W is able to connect as W-multi instead of EW190M2G2w.  
 \* 1: Low temp condition: Outdoor temperature 2°C.  
 Condenser actual pipe connections may vary from above pipe connections shown, please refer to technical manuals for full details.  
 Please refer to tube sizing charts for pipe selections and pipe length parameters.  
 Capacity Hot Water is available when outside ambient air temperature is above 7°C.

### NEW 2 way gas driven VRF with electrical power generator

SANYO's ECO G Power is a revolution in air conditioning design. Fitted with a permanent magnet, non-bearing type generator, it is the first VRF system that can supply heating, cooling, hot water and now also a supply of electrical power.

Each ECO G Power unit has a 4.0kW generator, which provides enough electricity to power 8 computers or other applications.

- Innovative technology that reduces CO<sub>2</sub> emissions by up to 30%
- Heat pump air conditioning system providing cooling or heating
- Can provide both electricity and hot water in heating and cooling mode
- Up to 4kW electricity generated
- Very efficient generator
- Hot water provided when cooling or heating when outside ambient air temperature is above 7°C
- 22kW hot water generation capacity
- 20HP model provides 56kW cooling or 63kW heating
- Can connect to up to 36 indoor units
- 200m maximum allowable piping length (L1) (equivalent - refer to technical manual)
- IU/OU capacity ratio 50 - 130%

**NEW**

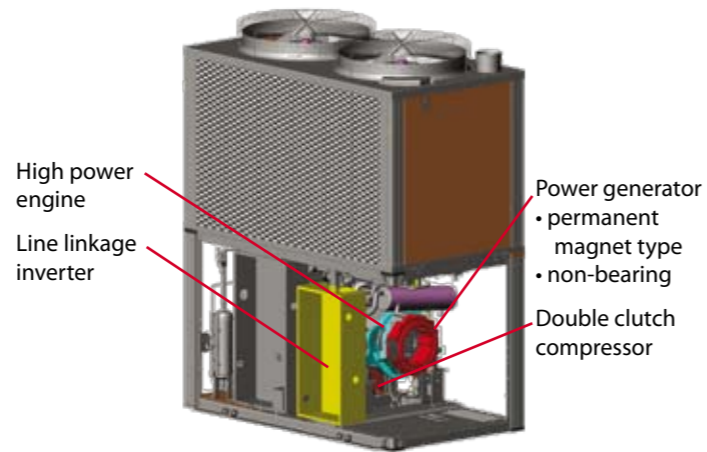

### Production of electricity

Generates from 2kW to 4kW depending on air conditioning load

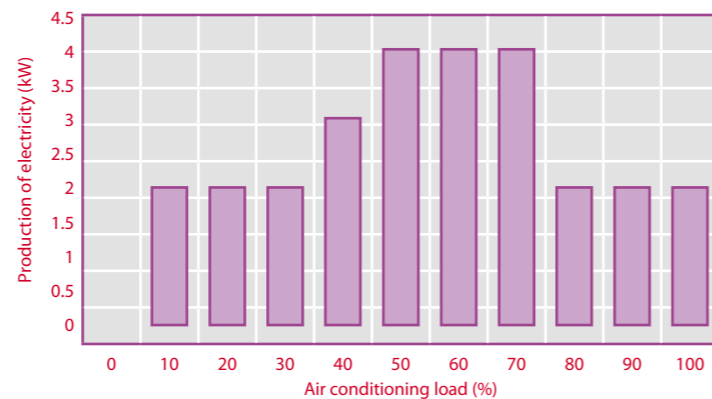

### Generate electricity during heating or cooling operation

Generate electricity and air conditioning (heating or cooling) at the same time by using remaining engine power. ECO G Power can generate from 2.3 to 4.0kW electricity at a generation efficiency of more than 40%.

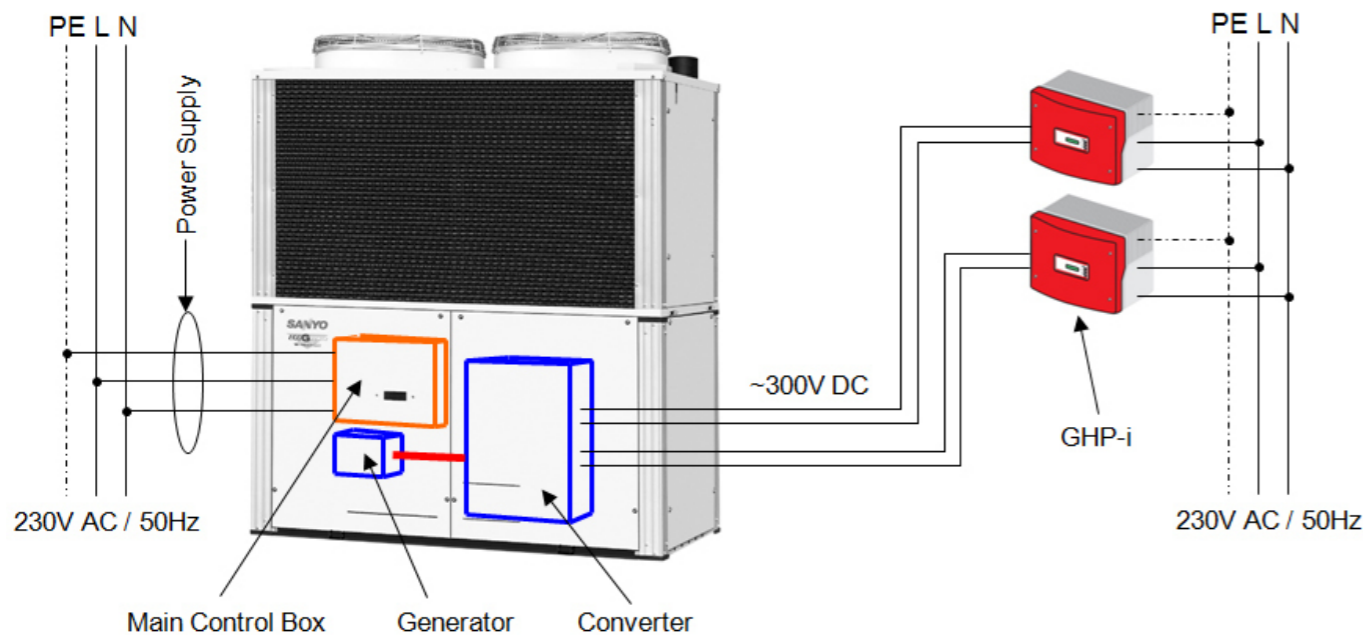

HP			20	33	36	40	45	
Model			SGP-EGW190M2G2W	SGP-EW120M2G2W SGP-EGW190M2G2W	SGP-EW150M2G2W SGP-EGW190M2G2W	SGP-EGW190M2G2W SGP-EGW190M2G2W	SGP-EGW190M2G2W SGP-EW240M2G2W	
Capacity	Cooling	kW	56.0	91.50	101.00	112.00	127.00	
	Heating	STD	63.0	103.0	113.00	126.00	143.00	
	Heating	Low temp*1	67.0	109.50	120.00	134.00	142.00	
	Hot water	kW	22.0	34.0	38.0	44.0	47.00	
Power generator capacity at rating	kW		DC 2.5 (Max 4.3)					
Electricity	Cooling	kW	1.35	2.20		2.70		
	Heating	kW	1.01		2.02		2.55	
Gas consumption	Cooling	kW	44.0 (38.3)*	68.50	75.60	88.00	104.90	
	Heating	STD	48.7 (43.0)*	76.80	84.80	97.40	101.00	
	Heating	LOW	62.1 (56.4)*	98.90	109.40	124.20	121.30	
	AVE							
COP Air conditioning only	Cooling		1.33 (1.41)*		1.29	1.23	1.18	
	Heating		1.34 (1.43)*	1.31	1.30	1.27	1.38	
	AVE		1.34 (1.42)*		1.30	1.25	1.28	
Max COP (Inc generator, hot water)	Cooling		1.78	1.81	1.80	1.78	1.69	
Height	Height	mm	2,248					
	Width	mm	1,800 + 100 (Min distance) + 1,800					
	Depth	mm	1,000 (+60)					
Weight	kg		875	1,660	1,685	1,740	1,720	
Starter amperes	A		30					
Pipe	Gas	Inches (mm)	1 1/8 (28.58)		1 3/8 (34.92)		1 5/8 (41.27)	
	Liquid	Inches (mm)	5/8 (15.88)					
	Balance	Inches (mm)	3/4 (19.05)					
Pipe fuel gas	mm		R3/4 (bolt, thread)					
Pipe exhaust drain port	mm		ø25 rubber hose					
Operation sound	dB(A)		58		61		63	
Indoor/outdoor capacity ratio			50-130%					
Number of indoor connections*			32		48			

Condenser actual pipe connections may vary from above pipe connections shown, please refer to technical manuals for full details. Please refer to tube sizing charts for pipe selections and pipe length parameters. Capacity Hot Water is available when outside ambient air temperature is above 7°C.

### Dimensions ECO G Power

	Size (mm)
① Gas refrigerant pipe (Gas tube)	ø28.58
② Liquid refrigerant pipe (Liquid tube)	ø15.88
③ Refrigerant balance pipe (Balance tube)	ø9.52
④ Exhaust gas drain hose	OD: Length:
⑤ Electrical power supply port	ø28
⑥ Inter-unit cable port	ø28
⑦ Inverter cable port	ø28
⑧ Inverter cable port	ø40
⑨ Fuel gas port	G: R3/4
⑩ Condensation drain opening	ø20
⑪ Rain and condensation outlet	
⑫ Engine exhaust outlet	
⑬ Suspension holes 4-ø20	
⑭ Anchor holes 4-ø24	
⑮ Segment display	
⑯ Coolant intake (top)	
⑰ Vent	
⑱ Hot water intake	Rp3/4
⑲ Hot water outlet	Rp3/4

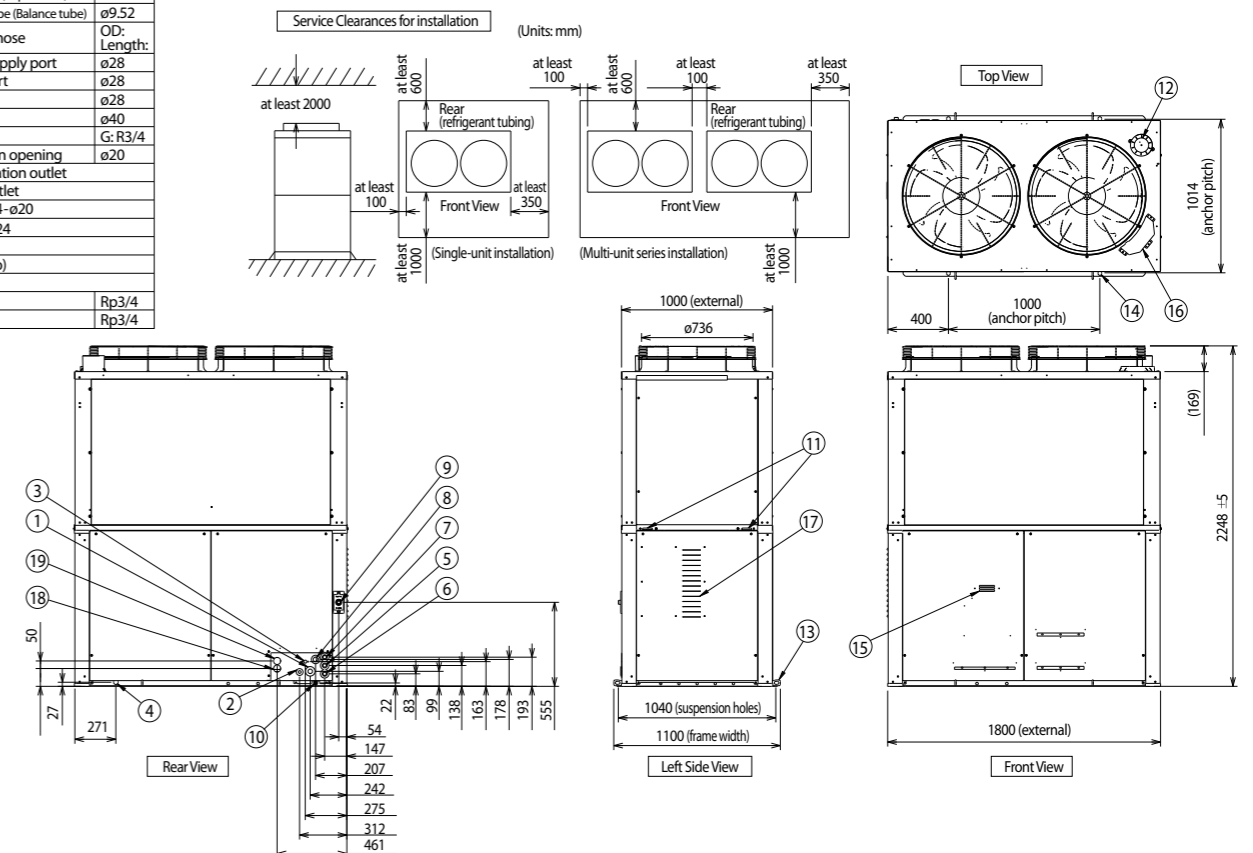

# Additional GHP Functions

## GHP Chiller available with outdoor unit capacities from 71kW

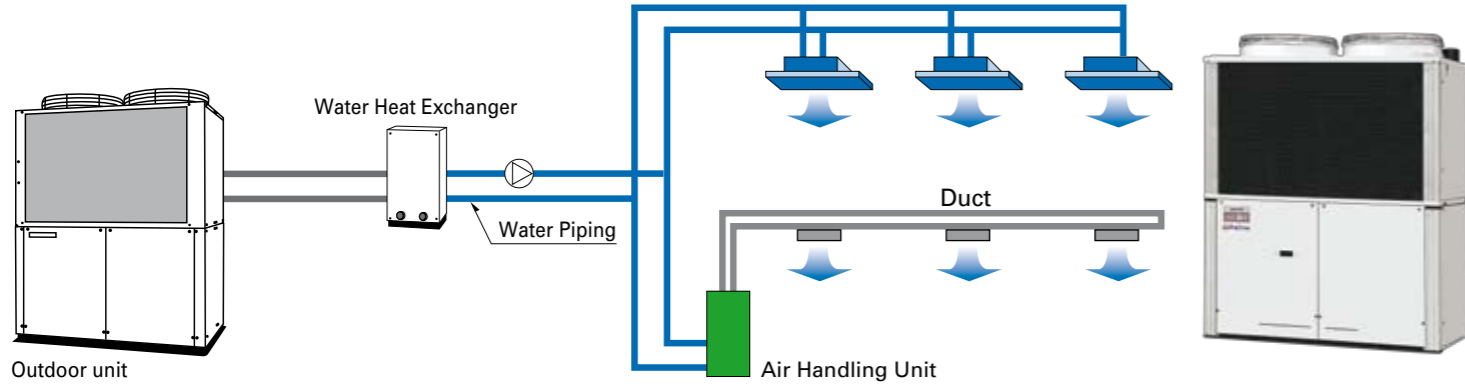

The SANYO ECO G Water Heat Exchanger can provide water at a wide range of temperatures suitable for a variety of commercial applications ranging from comfort air conditioning to food processing or the replacement of boilers and other systems.

- New 25 kW and 50 kW capacity models
- In cooling (chiller) mode provides water from -15°C to 15°C
- In heating mode can provide hot water up to 55°C, for example for under floor heating applications
- Includes water flow protection to prevent freezing
- Temperature sensor included
- S-Link communication is connectable with any controllers
- Split system means reduced installation cost and the use of a less powerful circulation pump
- One touch changeover between cooling and heating operation
- The system can accommodate up to 120m (actual length) of piping between the outdoor unit and the water heat exchanger, allowing flexibility of installation location
- The system uses antifreeze coolant, so it can produce cold water even at -15°C, thereby complying with "brine specifications"

Model No.		SGP-WE80M1	SGP-WE170M1
SGP-EW120M2G2W	Cooling capacity kW	25	30
	Heating capacity kW	30	35.5
SGP-EW150M2G2W	Cooling capacity kW	25	37.5
	Heating capacity kW	30	45
SGP-EW190M2G2W and SGP-EGW190M2G2W	Cooling capacity kW	25	50
	Heating capacity kW	30	60
SGP-EW240M2G2W	Cooling capacity kW	25	56
	Heating capacity kW	30	67
Electrical rating	Cooling power input kW	0.01	
	Heating power input kW	0.01	
Power supply		220/230/240V Single Phase 50Hz	
Size	Height mm	1,000	
	Width mm	550	
	Depth mm	965	
Weight	kg	125	160
Standard cold/hot water flow rate	m <sup>3</sup> /h	4.3	8.6
Hydrostatic loss	kPa	8.5	11.3
Holding water quantity inside the unit	m <sup>3</sup>	0.01	0.02
Minimum holding water quantity outside the unit	m <sup>3</sup>	0.28	0.50
Piping refrigerant	Gas pipe mm	ø22.22	ø28.58
	Liquid pipe mm	ø9.52	ø15.88
Heat exchanger		hot/cold heat exchanger	
Water circuit limit pressure	MPa	0.686	
Anti-freezing protection system		Protective thermostat	

Specifications subject to change without notice.

Operating condition	Cooling	Heating (standard)	Heating (low temperature)
Water temperature of water heat exchanger unit	Outlet 7°C	Outlet 45°C	Outlet 45°C
Outdoor side intake air temperature	35°C DB	7°C DB, 6°C WB	2°C DB, 1°C WB

Note: The gas consumption can be 110% of the specification value depending on the operating conditions.

## Hot water supply function (during cooling or heating operation)

SGP-EW120M2G2W    SGP-EW150M2G2W    SGP-EW190M2G2W    SGP-EW240M2G2W    SGP-EGW190M2G2W

The engine waste heat, which is normally exhausted into the atmosphere, is recovered via the heat exchanger and effectively used as hot water, so the GHP system acts as a subsystem that alleviates the load on the client's main hot water system and therefore offers "free" hot water.

Water heating capacity up to 65 kW (of 75°C hot water)

Hot water piping allowable pressure 0.7 MPa

Hot water circulation rate 2 - 3.9m<sup>3</sup>/h

Hot water pipe size 3/4 inch

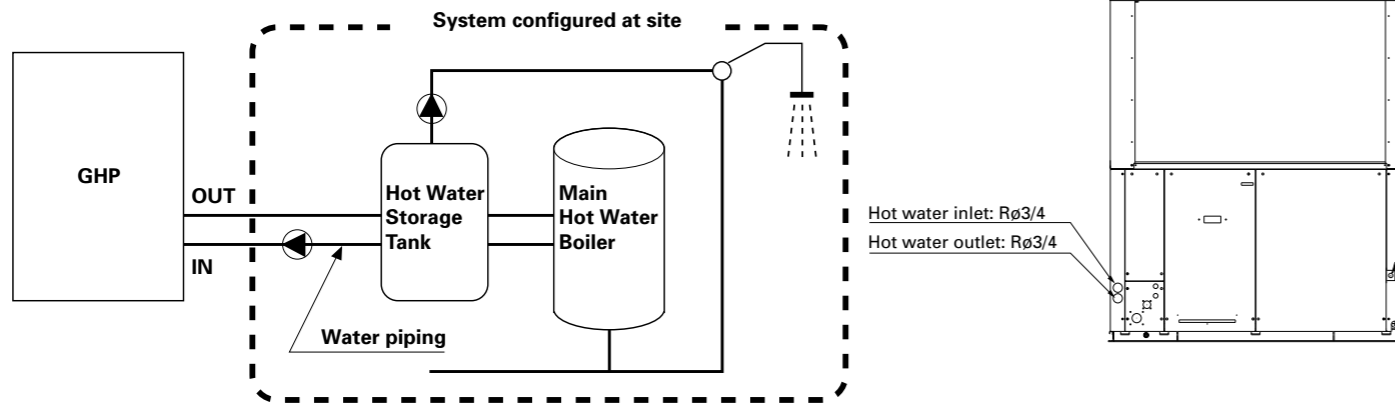

Rating Conditions: Cooling Indoor 27°C DB 19°C WB Outdoor 35°C DB 24°C WB Heating Indoor 20°C DB Outdoor 7°C DB 6°C WB

# GU Type Heat Exchanger & CFR Units

SANYO's new heat recovery ventilation system allows total control via a system network whilst modulating the temperature and humidity of incoming air supply.

- Integration of heat recovery ventilation and DX coil technology for optimum air temperature control
- Connects to all ECO & GHP outdoor units with a filter option
- 3 Way: Solenoid valve kit is required for each unit
- 2 Way: RAP kit is required for each unit



## Indoor unit specifications

Model Name		SPW-GU055XH	SPW-GU075XH	SPW-GU105XH
Air circulation (H) m <sup>3</sup> /h		500	750	1,000
Power source		220/230/240V, 1 phase - 50 Hz		
Fresh air load treatment capacity	UK Cooling kW	5.3 (1.7)*1	8.2 (2.6)*1	10.7 (3.4)*1
	UK Heating kW	6.5 (2.3)*1	9.8 (3.5)*1	12.6 (4.6)*1
Enthalpy exchange efficiency	UK Cooling %	59		
	UK Heating %	67		
Temp exchange efficiency		75		
Equivalent cooling capacity	kW	3.6	5.6	7.3
	BTU/h	12,000	19,000	25,000
Power input	Cooling kW	0.532	0.737	0.798
	Heating kW	0.532	0.737	0.798
Running current	Cooling Amps	2.4	3.2	3.5
	Heating Amps	2.4	3.2	3.5
Fan motor	Type	Sirocco fan		
	External static pressure-return air Pa	183 (170)	221 (188)	135 (88)
	External static pressure-supply air Pa	205 (182)	264 (218)	176 (137)
	Output kW	0.28 (4P)x2	0.35 (4P)x2	
Sound pressure level (C/H)	db(A)	46 (Cooling), 47 (Heating)	47 (Cooling), 48 (Heating)	48 (Cooling), 49 (Heating)
	Height mm	425	450	
Dimensions	Width mm	1785	1903	
	Depth mm	1000	1120	1220
	Liquid (flare) mm (inches)		6.35 (1/4)	
Piping connections	Gas (flare) mm (inches)		12.7 (1/2)	
	Drain piping		VP-25	
	Connection duct diameter mm		250	300
Net weight kg		134	153	168

The values in ( ) for the external static pressure and operating sound are for use of booster cable. \*1: Heat recovery capacity by heat exchanger. Data subject to change without notice.

The CFR-PHE uses a unique purifying Bioxigen system to produce negative ions this can reduce pollutants by up to 85% whilst improving, significantly air quality within most environments.

- High efficiency heat exchanger & Easy to clean filters

The CFR-PHE unit structure is constructed from Aluzink frame work and galvanised steel with 20 mm thick fire resistant acoustic insulation, reducing both weight and sound levels to a minimum. The system is supplied with ducted spigots which can be positioned either at the front or side of the unit to ease installation.



The high efficiency low pressure loss total heat exchanger is made of specially treated paper to enable the unit to be as efficient as 76% during normal operation. This allows system to recover both latent and sensible heat.

## Indoor unit specifications

Model CFR/ CFR-PHE		33	55	110	175	220
Nominal air flow *	m <sup>3</sup> /hr	300	620	920	1580	1850
External Static Pressure	pa	45	55	65	70	77
Sound Pressure **	dB(A)	43	51	50	53	52
Fans						
Power in	Watts	184	340	294	700	700
Absorbed power	A	0.75	1.8	2.2	4.4	4.8
Fan speeds	no	1		3		
Insulation Class		F				
Electrical supply	v/ph/htz	230/1/50				
Bioxigen Elements (PHE only)						
Number of elements		2 X C			2 X F	
Electrical supply	v/ph/htz	230/1/50				
Power in	Watts	8	8	8	8	8
Filter		EU3				
Paper Heat Exchanger	CFR-PHE					
Temperature Efficiency heating ***		76%	74%	72%	68%	73%
Temperature Efficiency cooling ****		62%	60%	58%	54%	59%

\* Nominal air flow \*\* Sound pressure 1.5 mts from the unit in free field \*\*\* Data referred to -5°C 80% RH OAT room condition 20°C 50% RH \*\*\*\* Data referred to 32°C 50% RH OAT room condition 26°C 50% RH





Rating Conditions: Cooling Indoor 27°C DB 19°C WB Outdoor 35°C DB 24°C WB Heating Indoor 20°C DB Outdoor 7°C DB 6°C WB

- Wider operation
- Self-diagnosing function
- Automatic fan operation
- Mild dry
- Comfortable auto-flap control
- Automatic restart function for power failure
- Air Sweep
- Built-in drain pump

Model size	7	9	12	16	18	22	25	36	48	60	76	96	Wireless remote control				
Capacity kW	Cooling 2.2 Heating 2.5	Cooling 2.8 Heating 3.2	Cooling 3.6 Heating 4.2	Cooling 4.5 Heating 5.0	Cooling 5.6 Heating 6.3	Cooling 6.4 Heating 7.0	Cooling 7.3 Heating 8.0	Cooling 10.6 Heating 11.4	Cooling 14.0 Heating 16.0	Cooling 16.0 Heating 18.0	Cooling 22.4 Heating 25.0	Cooling 28.0 Heating 31.5	Built-in infra red sensor	Separate infra red sensor	Functions		
Capacity BTU/h	Cooling 7,500 Heating 8,500	Cooling 9,600 Heating 11,000	Cooling 12,000 Heating 14,000	Cooling 15,000 Heating 17,000	Cooling 19,000 Heating 21,000	Cooling 22,000 Heating 24,000	Cooling 25,000 Heating 27,000	Cooling 36,000 Heating 39,000	Cooling 47,800 Heating 54,600	Cooling 54,600 Heating 61,500	Cooling 76,400 Heating 85,300	Cooling 95,500 Heating 107,500					
X Type Semi-Concealed Cassette	SPW-X075XH SPW-XDR74GXH56B Panel PNR-XD484GHAB	SPW-X095XH SPW-XDR94GXH56B Panel PNR-XD484GHAB	SPW-X125XH SPW-XDR124GXH56B Panel PNR-XD484GHAB	SPW-X165XH SPW-XDR164GXH56B Panel PNR-XD484GHAB	SPW-X185XH SPW-XDR184GXH56B Panel PNR-XD484GHAB		SPW-X255XH SPW-XDR254GXH56B Panel PNR-XD484GHAB	SPW-X365XH SPW-XDR364GXH56B Panel PNR-XD484GHAB	SPW-X485XH SPW-XDR484GXH56B Panel PNR-XD484GHAB	SPW-X605XH SPW-XDR604GXH56B Panel PNR-XD484GHAB			•				
XM Type Semi-Concealed	SPW-XM075XH Panel PNR-XM185	SPW-XM095XH Panel PNR-XM185	SPW-XM125XH Panel PNR-XM185	SPW-XM165XH Panel PNR-XM185	SPW-XM185XH Panel PNR-XM185								•	•			
US Type Concealed Duct	SPW-US075XH	SPW-US095XH	SPW-US125XH	SPW-US165XH	SPW-US185XH									•			
U Type Concealed Duct	SPW-U075XH SPW-UR74GXH56B	SPW-U095XH SPW-UR94GXH56B	SPW-U125XH SPW-UR124GXH56B	SPW-U165XH SPW-UR164GXH56B	SPW-U185XH SPW-UR184GXH56B		SPW-U255XH SPW-UR254GXH56B	SPW-U365XH SPW-UR364GXH56B	SPW-U485XH SPW-UR484GXH56B	SPW-U605XH SPW-UR604GXH56B				•			
DR Type Concealed Duct							SPW-DR254GXH56B	SPW-DR364GXH56B	SPW-DR484GXH56B		SPW-DR764GXH56B	SPW-DR964GXH56B		•			
K Type Wall Mounted Unit	SPW-K075XH	SPW-K095XH	SPW-K125XH											•	•		
KR Type Wall Mounted Unit				SPW-KR164GXH56B	SPW-KR184GXH56B		SPW-KR254GXH56B							•	•		
T Type Ceiling Mounted Unit			SPW-T125XH SPW-TDR124GXH56B	SPW-T165XH SPW-TDR164GXH56B	SPW-T185XH SPW-TDR184GXH56B		SPW-T225XH SPW-TDR254GXH56B	SPW-T365XH SPW-TDR364GXH56B	SPW-T485XH SPW-TDR484GXH56B					•	•		
FTR Type Floor/Ceiling Mounted Units	SPW-FTR74EXH56B	SPW-FTR94EXH56B	SPW-FTR124EXH56B	SPW-FTR164EXH56B	SPW-FTR184EXH56B	SPW-FTR224EXH56B								•	•		
FUR Type Floor/Ceiling Slim Concealed Duct	SPW-FUR74EXH56B	SPW-FUR94EXH56B	SPW-FUR124EXH56B	SPW-FUR164EXH56B	SPW-FUR184EXH56B	SPW-FUR224EXH56B								•			
FR Type Floor Standing Unit	SPW-FR74GXH56B	SPW-FR94GXH56B	SPW-FR124GXH56B	SPW-FR164GXH56B	SPW-FR184GXH56B		SPW-FR254GXH56B								•		
FMR Type Concealed Floor Standing Unit	SPW-FMR74GXH56B	SPW-FMR94GXH56B	SPW-FMR124GXH56B	SPW-FMR164GXH56B	SPW-FMR184GXH56B		SPW-FMR254GXH56B								•		
ADR Type Semi-Concealed Cassette 1-Way Air Discharge	SPW-ADR74GXH56B Panel PNR-AD124GHB	SPW-ADR94GXH56B Panel PNR-AD124GHB	SPW-ADR124GXH56B Panel PNR-AD124GHB											•	•		
SR Type Semi-Concealed Cassette 2-Way Air Discharge	SPW-SR74GXH56B Panel PNR-S124GHB	SR94GXH56B Panel PNR-S124GHB	SR124GXH56B Panel PNR-S124GHB	SR164GXH56B Panel PNR-S124GHB	SR184GXH56B Panel PNR-S124GHB		SPW-SR254GXH56B Panel PNR-S253GHANB							•	•		
LDR Type Semi-Concealed Slim Cassette		SPW-LDR94GXH56B Panel PNR-LD254GHAB	SPW-LDR124GXH56B Panel PNR-LD254GHAB	SPW-LDR164GXH56B Panel PNR-LD254GHAB	SPW-LDR184GXH56B Panel PNR-LD254GHAB		SPW-LDR254GXH56B Panel PNR-LD254GHAB							•	•		
GU Type Total Heat Exchanger		SPW-GU055XH		SPW-GU075XH	SPW-GU105XH										•		





# Individual Control Systems Overview

A wide variety of control options to meet the requirements of different customers.

Operation system	Individual control systems			Timer operation
Requirements	Normal operation	Operation from each seat	Simple operation	Daily and weekly programme
External appearance				
Type, model name	Timer wired remote controller RCS-TM80BG	Wireless remote controller RCS-SH80BG.WLB RCS-TH80BG.WLB RCS-BH80AG.WLB RCS-TRP80BG.WLB RCS-SH1BG	Simplified remote controller RCS-KR1EG	Schedule timer SHA-TM64AGB
Number of indoor units which can be controlled	1 group, 8 units	1 group, 8 units	1 group, 8 units	64 groups, max. 64 units
Use limitations	Up to 2 units can be connected per group.	Up to 2 units can be connected per group.	Up to 2 units can be connected per group.	Power supply from the system controller. When there is no system controller, connection is possible to the T10 terminal of an indoor unit.
Connectable indoor unit	4 series indoor unit	4 series indoor unit	4 series indoor unit	4 series indoor unit
Function				
ON/OFF	•	•	•	-
Mode setting	•	•	•	-
Fan speed setting	•	•	•	-
Temperature setting	• <sup>*1</sup>	• <sup>*1</sup>	• <sup>*1</sup>	-
Air flow direction	•	•	•	-
Permit/Prohibit switching	-	-	-	-
Weekly programme	•	-	-	•

\*1 Setting is not possible when a remote control unit is present. (Use the remote control for setting.)

# Centralised Control Systems Overview

Requirements	Centralised control systems			
	Operation with various function from central station	Only ON/OFF operation from central station	Simplified charge ratio for each tenant	
External appearance			 Web application	
Type, model name	System controller SHA-KC64AGB	ON/OFF controller SHA-KC16KAGB	Intelligent controller SHA-KT256EG	Communication adaptor SHA-KA128AGB
Number of indoor units which can be controlled	64 groups, max. 64 units	16 groups, max. 64 units	64 units x 4 systems, max. 256 units	2 systems, max. 128 units
Use limitations	Up to 10 units can be connected to one system. Main unit/sub unit (1 main unit + 1 sub unit) connection is possible. Use without remote controller is possible.	Up to 8 units (4 main units + 4 sub units) can be connected to one system. Use without remote controller is impossible.	A communication adaptor (SHA-KA128AGB) must be installed for three or more systems.	Maximum 500 indoor units (128 per communication adaptor)
Connectable indoor unit	4 series indoor unit	4 series indoor unit	4 series indoor unit	4 series indoor unit
Function				
ON/OFF	•	•	•	•
Mode setting	•	-	•	•
Fan speed setting	•	-	•	•
Temperature setting	•	-	•	•
Air flow direction	• <sup>*1</sup>	-	• <sup>*1</sup>	• <sup>*1</sup>
Permit/Prohibit switching	•	•	•	•
Weekly programme	•	-	•	•



Contact your local SANYO distributor for brochures on all other ranges of air conditioning and heating solutions



ELECTRIC VRF



COMMERCIAL SPLIT SYSTEMS



ROOM AIR CONDITIONERS



CO<sub>2</sub> ECO HEATING SYSTEM



Indicates conformation with EC Directives



ISO 9001: 2001  
Certificate Number: JQ116B



ISO 14001: 2001  
Certificate Number: ECOJ0303-33

SANYO reserves the right to make any variation in specification to the equipment described or to withdraw or replace products without prior notification or public announcement. All descriptions, illustrations, drawings and specifications in this publication are given in good faith, but are intended to present only general particulars and shall not form any part of the contract. For full installation details, please contact your SANYO distributor.

#### Rating Conditions

The cooling and heating capacities are based on the following conditions:  
Cooling: Indoor temperature 27°C DB/19°C WB, Outdoor temperature 35°C DB/24°C WB.  
Heating: Indoor temperature 20°C DB, Outdoor Temperature 7°C DB 6°C WB.

Printed using paper produced from 50% recycled material and 50% from sustainable forestry

[www.sanyoaircon.com](http://www.sanyoaircon.com)

**SANYO** Air Conditioners. The natural choice.