

mellerware®

makes life easier

TREVISO
coffee
maker



12 Cup capacity

Keep warm
function

Anti-drip valve



complies with
INTERNATIONAL
IEC60335
SAFETY SPECIFICATIONS

m
800W

2 YEAR
GUARANTEE

Model:
29500A



PLEASE READ ALL THE INSTRUCTIONS BEFORE USING THIS PRODUCT

Important safeguards

1. Please read these instructions carefully before using this appliance and save it for future reference.
2. The appliance is not intended for use by persons (including children) with reduced physical, sensory or mental capabilities, or lack of experience and knowledge, unless they have been given supervision or instruction concerning use of the appliance by a person responsible for their safety.
3. Children should be supervised to ensure that they do not play with the appliance.
4. Do not immerse the power supply cord, plug, or appliance itself in water or any other liquids.
5. The appliance should only be connected to an earthed socket. Make sure the voltage indicated on the appliance corresponds to the local mains voltage before plugging in.
6. Never leave the machine operating when unattended.
7. The supply cord should be regularly examined for signs of damage. If the supply cord is damaged, it must be replaced by the manufacturer, its service agent or similarly qualified persons in order to avoid a hazard.
8. Do not operate the appliance with a damaged cord or plug, or after the appliance malfunctions, or if it has been damaged in any manner. Return the appliance to the nearest authorized service agent for examination, repair or adjustment.
9. This appliance is intended for household use and similar applications such as:
 - Staff kitchen areas in shops, offices and other working environments
 - Farm houses
 - Hotels, motels and other residential type environments
 - Bed and breakfast type environments.
10. Never use the appliance outdoors and always place it in a dry environment.
11. Always remove the plug from the socket in case of any malfunction, before filling or after use, or before cleaning.
12. Do not allow the appliance or its power supply cord to touch hot surfaces or to come into contact with any heat sources.
13. Keep the supply cord out of reach of children or incompetent persons. Never unplug or move the appliance by pulling the cord. Do not wind the cord around the appliance or twist it.
14. Stand the appliance on a stable, flat surface.
15. Never touch the hot parts of the appliance.
16. Always lift the jug by the handle.
17. Be careful not to get burnt by the steam escaping from the filter.
18. Never use your coffee maker without water in it. Only use fresh, cold water to brew coffee.
19. Never fill the water tank beyond the max level. Do not use your coffee maker when it is overflowing.
20. Never put the jug in an oven (including microwave oven) to warm up coffee.
21. Brewed coffee is hot. Handle the jug with care to avoid burning.
22. Handle the glass jug with care as the glass is very fragile. Never use the appliance if the jug shows any signs of cracks.
23. Never place the empty or almost empty glass jug on the warm plate when the coffee maker is switched on, or on any other hot surfaces.
24. Never use accessories which are not recommended by the manufacturer. They could constitute a danger to the user and could risk damaging the appliance.
25. Always set any control to "off" before unplugging from the socket.
26. Make sure the ambient temperature is above 0°C, otherwise the appliance will not function properly.
27. Always descale the appliance regularly to ensure optimum performance and to prevent malfunction.





1. Make sure the appliance has cooled down before cleaning or storing.
2. The appliance may release smoke and or smell when you use it for the first few times because of the oil on some parts. This will disappear after a few uses.

Technical data

Ratings: 220-240V~ 50Hz, 800W

Nominal capacity of water tank: 1.2L

Know your coffee maker

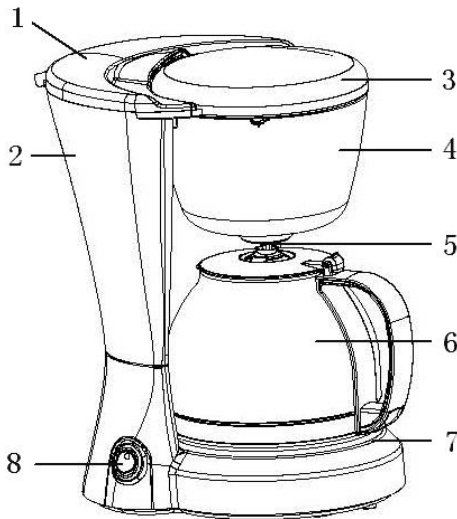

1. Water tank cover
2. Water tank
3. Top lid
4. Filter holder
5. Anti-drip valve
6. Glass jug
7. Warming plate
8. On/Off switch with indicator lamp

Operation

1. Lift the water tank cover and fill with fresh cold water to required level.
2. Close the water tank cover.
3. Swing the filter holder out. Put an adequate quantity of ground coffee into the permanent filter (if applicable) or paper filter inside the filter holder.

4. Return the filter holder to original position, make sure it is fixed properly in place.
5. Place the jug on the warming plate.
6. Switch the appliance on by pressing the On/Off switch, the indicator lamp will light up and the appliance will start working.
7. The appliance will brew until the water tank is emptied thereafter it will automatically go into keep-warm mode. The warming plate will keep the brewed coffee warm at:
 1. Above 72°C in half an hour.
 2. Above 68°C in an hour.

Cleaning

1. Do not forget to remove the plug from the socket and make sure the appliance has cooled down before cleaning.
2. Never immerse the cord, plug, or appliance itself in water.
3. Once the appliance has cooled down completely wipe the outside with a soft, moist cloth. Never use metal polish.
4. Clean the permanent filter (if applicable) and other detachable parts in warm soapy water. Rinse with fresh water and dry before reassembling.
5. Clean the inside of the jug with a soft brush in warm soapy water. Rinse with fresh water and dry before next use.
6. To ensure the appliance works at an optimal level it is recommended that the appliance be cleaned once every three months.
7. Store the appliance in a dry, cool place. Note: Never use a dishwasher to clean the jug.

Descaling

The appliance needs to be descaled regularly otherwise the coffee taste may be affected. The deposited scale inside the machine may also cause permanent and irreparable damage.

Signs that descaling is necessary:

- Increase in noise during boiling,
- Brewing time is longer than normal,





- Appliance switches off before the water tank is empty.

Descaling frequency depends on the water hardness and the brewing frequency. Generally, descaling should be done periodically as follows:

- With soft water, at least once every 3 months.
- With hard water, at least once every month.

If in doubt about the hardness of your water, contact your local municipality.

It is recommended to use only liquid descalers suitable for coffee makers. Read the descaling instructions carefully before use.

1. Mix adequate descaler with cold water in a measuring jug.
Note: Never use a powder descaler.
2. Fill the water tank up to the Max level

with the prepared solution.

3. Operate the appliance until the water tank is empty as if you had brewed a jug of coffee, but without a paper filter and ground coffee in the filter holder.
4. Repeat steps 1 to 3 for another descaling cycle.

Note: Never refill the water tank with the used descaling solution because it is no longer active.

5. Operate two more brewing cycles with fresh, cold water to remove all descaler solution residues.
6. Important:
 - A. Never interrupt the descaling process.
 - B. Malfunctions caused by scale deposited inside the appliance are not covered by the guarantee if the descaling process is not carried out properly.





Troubleshooting

If you have a problem, you may find the solution in the table below. In case these solutions can not solve your problem yet, please contact with the nearest authorized service agent for examination, repair or adjustment.

Problem	Solution
The appliance does not work.	Make sure the voltage indicated on the appliance corresponds to the local mains voltage. Make sure the appliance has been plugged in & switched on.
Water leaks out of the appliance.	Check if the water tank is filled beyond the MAX level.
The appliance produces a lot of noise and steam during brewing.	Make sure the water tank is not filled with hot water. The appliance needs to be descaled (see heading 'Descaling').
Coffee grounds enter into the jug.	Check if the filter holder has overflowed because there is too much ground coffee in the filter, or the jug has not been placed correctly under the filter holder, or you removed the jug after 30 seconds during brewing. Check if the filter is torn or you use the wrong size of paper filter.
Brewing coffee takes longer than usual.	The appliance needs to be descaled (see heading 'Descaling').
The coffee maker switches off before the water tank is empty.	The appliance needs to be descaled (see heading 'Descaling').
The coffee is not strong enough.	Check if used ground coffee is not enough. It should be one heaped measuring spoon of ground coffee for each cup. Check if you use ground coffee with mild flavour.
The coffee is too strong.	Check if used too much ground coffee. It should be one heaped measuring spoon of ground coffee for each cup. Check if you have used ground coffee with strong flavour.
The coffee does not taste good.	Check if you leave the glass jug with coffee on the warm plate too long, especially if it only contains a small amount of coffee.
The coffee is not hot enough.	Check if the brewed coffee is too little. The coffee will warm longer if you brew more. Make sure you place the glass jug properly on the warm plate.
The jug is difficult to place in the appliance or remove from the appliance.	Make sure the lid of the jug & filter basket are in right position. Tilt the jug in an angle to place or remove it. Be careful not to spill the hot coffee for avoiding scald.
There is less coffee in the jug than expected.	Check if you have placed the jug properly on the warm plate, in a manner that prevents the coffee from flowing out of the coffee filter. The appliance needs to be descaled (see heading 'Descaling').





creative housewares

🏠 20 Tekstiel Street, Parow, Cape Town, 7493, South Africa

✉ P.O. Box 6156 Parow East, 7501, South Africa

☎ +27 21 931 8117 📠 +27 21 931 4058

Service Centre Helpline: 086 111 5006

🌐 www.creativehousewares.co.za

