

Indulge your senses
Miele's benchtop coffee machines

CM5



The last piece of the puzzle

... from the built-in appliance specialist!



Built-in coffee machine with a fresh bean system

In 1998, Miele was the original inventor of the built-in, fully automatic coffee machine concept for fresh beans, and learnt over the last decade or so, what the most demanding customers for built-in appliances expect when it comes to preparing beautiful coffee in the convenience of their own home.



Built-in coffee machine with the Nespresso capsule system

If you know and appreciate the convenience and choice that the Nespresso capsule system offers, Miele is the only manufacturer offering a built-in solution, integrating it into your kitchen design, together with matching ovens and even a cup warmer.



Finally, a benchtop coffee machine with the fresh bean system from Miele

In addition to the myriad of options when choosing a set of appliances - think steam or microwave combi oven as second appliance to a built-in Miele oven - the Miele CM 5 freestanding coffee machine now allows customers with limited space to no longer having to compromise when selecting a freestanding coffee machine.

The CM5 offers Miele's tried and tested coffee technology, manufactured to the highest of Miele's quality standards and performance expectations in an attractive, compact package for placement on your benchtop, to either complete or just start your collection of Miele cooking appliances.

Great coffee

... using the best ingredients!



Aroma-protecting conical grinding mill

For the best possible coffee aroma, only the best grinding mill is built into Miele coffee machines. The high-quality abrasion-resistant steel conical grinding mill maintains the aroma as it grinds the beans, time after time.



Ground coffee chute

In addition to the fresh bean container the Miele CM 5 also features a chute for ground coffee, which allows you to dispense a second type of coffee, e.g. when you have guests not sharing the same appreciation for your favourite beans and prefer decaffeinated instead.

For one off changes, simply use ground coffee in the chute without having to change the beans in the container altogether.



Aromatic System

For the perfect and intensive coffee aroma, the dynamic Miele brew unit expands when water flows in, allowing the ground coffee and the water to mix more thoroughly. After the brewing process the volume in the brew container decreases, the coffee powder is squeezed and then expelled into the waste container.

Your benefit: optimum extraction of all of the enticing flavours and aromas that make coffee so irresistible.



Cappuccinatore for perfect froth

It's never been so easy to prepare hot milk and froth - straight into the cup, or a separate container, at the push of a button. The Cappuccinatore draws the milk from a separate container via a tube. In seconds it heats or froths the milk directly into the glass or cup. Unbelievably easy to clean under running water, the Miele Cappuccinatore allows you to enjoy delicious cappuccino or latte macchiato at its best - quick and easy.

A stainless steel container (pictured), to keep milk fresh for longer and for direct connection to the Cappuccinatore is available as optional accessory.



Heated cup warmer

To serve coffee at the optimum temperature, without losing any of the heat that adds to the enjoyment, pre-heated cups are essential. Rather than using hot water from the machine, the CM 5100 offers an actively heated cup-rack with space for up to six espresso or three cappuccino cups. For added convenience, the heater can be timer-activated to come on in the morning before you are ready to have your first coffee.

Easy to use

... even with sleepy eyes!



Intuitive operation

All functions on the CM 5 can be called up at the push of a button on the clear text display which is ergonomically-angled so that you don't have to bend down to view it, and gives you the best view at all times. Simply select your favourite drink to start the automatic preparation. The clear text display - plain English with a choice of another 13 languages - will inform you automatically if you need to refill water or beans, or when the waste container or the drip tray is full.

The display perfectly matches those of other Miele appliances perfectly - design from the same mould to showcase you have a complete and true "Miele Kitchen".



Individually adjustable parameters

All parameters for a perfect cup of coffee can be set according to individual taste: amount of coffee and water, coarseness of the grind and temperature. And the beauty of the fully automatic Miele benchtop coffee machine is that you only have to do it once to suit your preferences, and then your perfect coffee will be delivered every time you simply press the button.



Height-adjustable spout

The spout of the Miele CM 5 is fully height-adjustable from 7 cm to 13 cm, giving you enough space for tall latte macchiato glasses. And the lowest setting is the perfect height for espresso cups, dispensing coffee without unsightly and heat-dissipating splashing and thus protecting the perfect cr ma.



Quiet operation

Great efforts have been undertaken with extensive sound matting around the grinder and a sound optimised pump to reduce the operating sound. Discover in-store or in your nearest Miele Gallery whether you can afford to prepare coffee when you feel like it, even if you have a very early start to your day while everyone else in the house is still fast asleep!





Regular maintenance

... made real easy!



Convenient cleaning programme

With its integrated cleaning programmes, the CM 5 makes light work of the cleaning. With only a few presses of a button, optimum cleaning, timely degreasing of the brew unit and descaling of the water-carrying components - as reminded by the display - is carried out automatically with no fuss by the machine, and explicit user guidance via the clear-text display. This not only gives you peace of mind that the machine is in its optimum working condition but also assists with the life-span of the appliance.



Removable cappuccinatore

After you have used your cappuccinatore to make hot milk or froth, the unit can be completely removed and easily cleaned under running water. The clear tube serves as an immediate reminder to check for any milk residues to ensure healthy enjoyment of milk based drinks.



Automatic rinsing function

When the machine is switched on, the spouts are automatically rinsed, ensuring a freshly-cleaned and warm system is ready and waiting from the first cup. The rinsing function is also automatically activated on switching off the machine - perfect hygiene from Miele.



Easily removable brew unit

The brew unit is at the heart of the coffee preparation process. The brew unit on Miele coffee can easily be removed by hand and rinsed under running water, ensuring consistently high quality coffee and a longer lifespan for your machine.

Being able to easily access and remove the brew unit without special tools gives you peace of mind that there are no stray coffee particles building up which could clog up the system or which, with the warmth and humidity in the coffee machine, could develop into unhealthy micro-organisms over time.

Designed to last

... and last, and last, and last!



Proverbial Miele quality

Miele kitchen appliances, including dishwashers and fridge/freezer combinations, as well as laundry care appliances and vacuum cleaners are renown for their reliability and long life. This can only be achieved by using high quality components inside and out, and Miele sets the highest standards.

For the coffee machine this means that on the outside high-quality stainless steel elements underline the premium appeal, while on the inside only the best components are used and configured in a way that ensures optimum and reliable operation for a very long time.

The Miele philosophy: first class quality for first class coffee!



Ongoing quality control

A long-standing knowledge of what it takes to consistently and reliably create an outstanding coffee experience, backed by rigorous and ongoing quality control vouch for the highest quality you expect from the Miele CM5 series of benchtop coffee machines.



Peace of mind

The Miele CM5 series of benchtop coffee machines are tested to last 20 years. This equates to approx. 50,000 coffee or espresso delivery cycles.

Miele coffee machines stand for unparalleled quality - quality you can depend on, all day, every day, morning after morning!



Features & benefits



	CM 5000 Coffee machine	CM 5100 Coffee machine	Why spend more?
Coffee experience			
Easy preparation of espresso, coffee, cappuccino, latte macchiato, milk froth, hot milk and hot water	●	●	
Automatic drink delivery of			
Espresso single/double + Coffee single/double	●	●	
User convenience			
Multi-lingual clear text display with self-explanatory user menu	●	●	
Choice of languages	English plus 13 others	English plus 13 others	
Features			
Height-adjustable coffee spout with stainless steel cover/max suitable cup height	●/13 cm	●/13 cm	
Cappuccinatore for simple addition of hot milk or milk froth	●	●	
Activation of steam valve	manually	electronically	Automated process to froth milk for added convenience
Heated cup warming area (chromed metal)	–	●	Warm cups for optimum coffee enjoyment; timer-activated
Appliance fascia in brushed stainless steel	–	●	High-end appeal, to match your built-in Miele appliances
Programmable on/off time	●	●	
Energy-saving Eco-mode programmable	●	●	
Programmable system lock for child safety	●	●	
Drinks counter	●	●	
Ground coffee chute for alternative coffee type	●	●	
Adjustable grind quality	●	●	
Programmable amount of coffee and water as well as temperature levels	●	●	
Programmable automatic switch-off	after 15 min – 9 hrs	after 15 min – 9 hrs	
Clear-text maintenance reminders			
Descaling, cleaning of the percolator unit, emptying of drip tray, clearing of ground coffee waste container	●	●	
Refill fresh water and beans	●	●	
Container capacity for ground coffee waste	approx. 11 portions	approx. 11 portions	
Technical features			
Powerful pump (15 bar) with high quality stainless steel flow-through heater	●	●	
Conical grinder from hardened steel	●	●	
Capacity of fresh bean container	250 g	250 g	
Capacity of fresh water tank	1.8 l	1.8 l	
Ease of cleaning/hygiene			
Easily accessible and removable brew unit	●	●	
Automatic cleaning and rinsing programmes	●	●	
Easy cleaning of milk pipes and Cappuccinatore	●	●	
Standard accessories			
Original Miele descaling agent/Original Miele cleaning tablets	Starter kit	Starter kit	
Additional coffee spoon for ground coffee	●	●	
Quick operating guide with storage facility on the back of the unit	●	●	
Test strip to determine water hardness	●	●	
Optional accessories			
Original Miele descaling tablets/cleaning tablets	●/●	●/●	
Stainless-steel container to keep milk fresh for longer, 0.5 l capacity, for connection to Cappuccinatore for optimum milk froth delivery	Optional	Optional	
Technical data			
Connection (V)/rated load (W)	230/1,450	230/1,450	



Coffee machines

Optional accessories



MB-CM 5 Stainless steel milk flask

Suitable for Miele freestanding coffee machines. Keeps milk fresh and cool for longer, holds 0.5l



Original Miele descaling tablets

Suitable for all Miele coffee machines, required for optimum descaling of the water carrying parts, to be applied as prompted by the machine (intervals depending on water hardness)



Original Miele cleaning tablets

Suitable for all Miele coffee machines, required for optimum degreasing of the brew unit, to be applied as prompted by the machine (200 coffee intervals recommended)

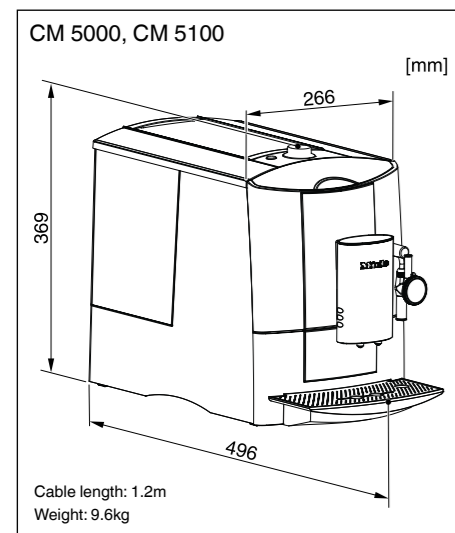

Miele Australia Pty. Ltd.
ACN 005 635 398
ABN 96 005 635 398

Miele Australia Pty. Ltd.
Head Office
1 Gilbert Park Drive
Knoxfield VIC 3180
Tel: 03 9764 7100

Miele Gallery Knoxfield
1 Gilbert Park Drive
Knoxfield VIC 3180
Tel: 03 9764 7670

Miele Gallery South Melbourne
208-210 Coventry Street
South Melbourne VIC 3205
Tel: 03 9764 7199

Miele Gallery and Office Sydney
3 Skyline Place
Frenchs Forest NSW 2086
Tel: 02 8977 4230

Miele Gallery and Office Brisbane
39 Harvey Street North
Eagle Farm QLD 4009
Tel: 1800 798 578

Miele Gallery and Office Adelaide
83-85 Sir Donald Bradman Drive
Hilton SA 5033
Tel: 1800 018 770

Miele Gallery and Office Perth
205-207 Stirling Highway
Claremont WA 6010
Tel: 1800 094 872
www.miele.com.au

Miele New Zealand Limited
Unit L, 10-20 Sylvia Park Road
Mt Wellington Auckland 1060
New Zealand
Tel: 0800 264 353
www.miele.co.nz

Miele Global Headquarters
Miele & Cie. KG
Carl-Miele Strasse 29
D 33332 Gütersloh
Federal Republic of Germany

Foreign Sales Companies

(A)	Miele Ges.m.b.H., Wals/Salzburg
(AUS)	Miele Australia Pty. Ltd., Melbourne
(B)	N.V. Miele S.A., Mollem
(CDN)	Miele Limited, Vaughan/Ontario
(CH)	Miele AG, Spreitenbach
(CL)	Miele Ltda., Santiago de Chile
(CN)	Miele Shanghai Trading Ltd., Shanghai
(CZ)	Miele spol.s.r.o., Brno
(D)	Miele & Cie. KG, Gütersloh
(DK)	Miele A/S, Glostrup/Copenhagen
(E)	Miele S.A., Alcobendas/Madrid
(EST)	Miele OÜ, Tallinn
(F)	Miele S.A.S., Le Blanc-Mesnil/Paris
(FIN)	Miele Oy, Vantaa/Helsinki
(GB)	Miele Company Ltd., Abingdon
(GR)	Miele Hellas E.P.E., Psychiko-Athens
(H)	Miele Kft., Budapest
(HK)	Miele Hong Kong Ltd., Hong Kong
(HR)	Miele d.o.o., Zagreb
(I)	Miele Italia S.R.L., Eppan
(IND)	Miele India Pvt Ltd., New Delhi
(IRL)	Miele Ireland Ltd., Dublin
(J)	Miele Japan Corp., Shibuya-ku/Tokyo
(KZ)	Miele Liability Partnership, Almaty
(L)	Miele s.à r.l., Luxembourg
(LT)	Miele Appliances UAB, Vilnius
(LV)	Miele SIA, Riga
(MAL)	Miele Sdn Bhd, Kuala Lumpur
(MEX)	Miele S.A. de C.V., Mexico City
(N)	Miele AS, Rud/Oslo
(NL)	Miele Nederland B.V., Vianen
(NZ)	Miele New Zealand Ltd., Auckland
(P)	Miele Portuguesa Lda., Carnaxide/Lisbon
(PL)	Miele Sp. z o. o., Warsaw
(RO)	Miele Appliances S.R.L., Otopeni
(ROK)	Miele Korea Ltd., Seoul
(RU)	000 Miele CIS, Moscow
(S)	Miele AB, Solna/Stockholm
(SGP)	Miele Pte. Ltd., Singapore
(SK)	Miele spol.s.r.o., Bratislava
(SLO)	Miele d.o.o., Ljubljana
(SRB)	Miele d.o.o., Belgrade
(TR)	Miele Elektrikli Ltd. Sti., Levent/Istanbul
(UA)	Miele LLC, Kiev
(UAE)	Miele Appliances Ltd., Dubai
(USA)	Miele, Inc., Princeton/New Jersey
(ZA)	Miele (PTY) Ltd., Bryanston/Johannesburg

Protecting the environment:
This brochure is printed on paper that is FSC accredited and bleached using an oxygen process that is elemental chlorine free.

All information correct at time of brochure print. Alteration rights reserved in the interest of continued productimprovement.