

IT-42 Installation Guide

INTRODUCTION

The IT-42 is an output isolation transformer accessory for the QSC CX 302 amplifier, allowing it to drive two 25-, 70-, and 100-volt distributed lines in stereo or parallel, or a single 140- or 200-volt line in bridged mono. It mounts conveniently to the back of the amplifier and requires no additional rack space.

In stereo or parallel modes, the two distributed lines may be loaded at up to 400 watts each. In bridged mono, the distributed line may be loaded at up to 800 watts.

Figure 1 shows the necessary mounting and configuration features of the IT-42

1. Mounting tabs
2. Transformer input wires with spade lug connectors
3. Isolated output barrier strip
4. Transformers
5. Slotted mounting tabs (× 2)
6. #8-32 × 5/16" Philips screw, black (× 2), *included*

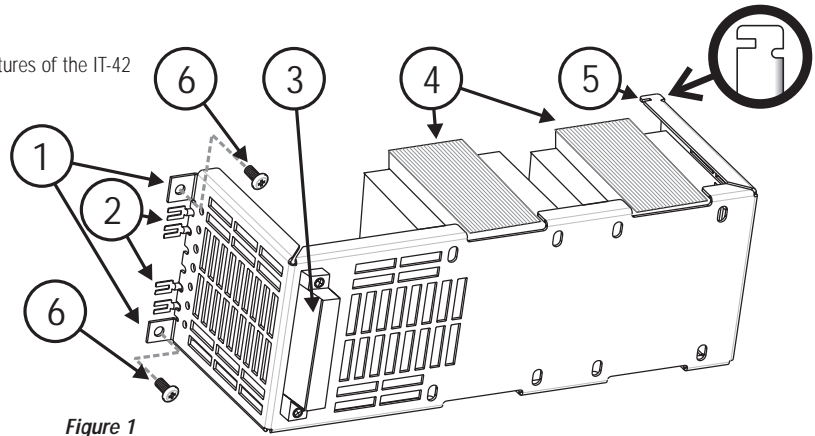

Figure 1

INSTALLATION

Although the IT-42 transformer accessory can be installed while the amplifier is already rack mounted, installation is much easier with the amplifier out of the rack and placed face-down so it rests on its front panel.

CAUTION: Turn off the amplifier before installing the IT-42 accessory.

1. Open the safety shroud over the amplifier's output barrier strip. Fully loosen—but do not remove—the two screw terminals at the top and the two at the bottom.
2. Align the spade lug connectors on the transformer input wires with their respective screw terminals and slide them fully onto the screws. Tighten the screw terminals.
3. Insert the slotted mounting tabs on the right end of the IT-42 into the slots in the amplifier chassis (Figure 2).
4. Align the holes in the mounting tabs on the left end of the IT-42 with the threaded holes in the amplifier chassis. Insert and tighten the mounting screws.
5. Press the right end of the bracket in to the left so that the slotted tabs lock to the amplifier and will not pull out (Figure 3).

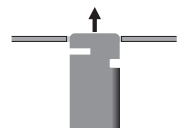

Figure 2

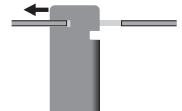

Figure 3

Rack mounting

The IT-42 adds to the depth of the amplifier, so you must allow more space at the rear of the rack. See Figure 4. Because of the additional weight of the transformers, it is important to support the amp at the back, even in fixed installations. Rear rack ear kits for QSC amplifiers are available from OSC's technical services department or from your dealer or distributor.

If you are using in the same rack two or more amplifiers with transformer accessories, separate them by at least one rack space to minimize crosstalk.

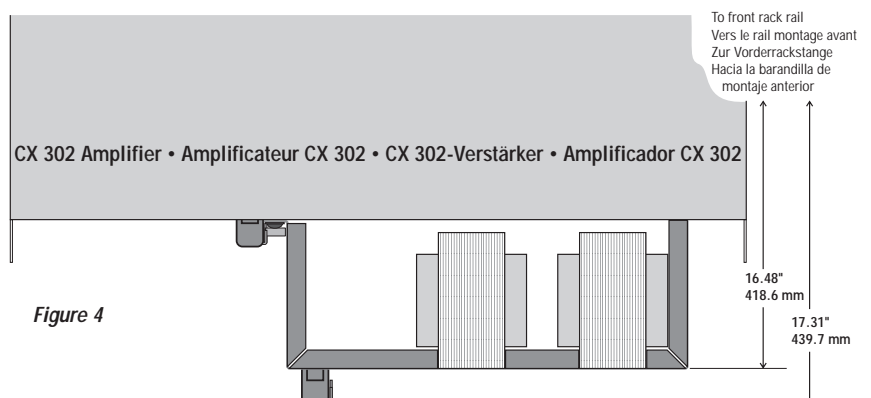

Figure 4



TD-000081-00
Preliminary

CONFIGURATION

With the IT-42 installed, the CX 302 amplifier can operate in several different configurations listed below.

TWO-CHANNEL OR TWO-ZONE OPERATION (STEREO OR PARALLEL)

- Both channels 25V
- Both channels 70V
- Both channels 100V
- One channel 25V, the other 70V or 100V
- One channel 70V, the other 100V

BRIDGED MONO OPERATION

140V or 200V

Amplifier settings: To minimize transformer saturation, we recommend *always* using the amplifier's **75 Hz** input filters. We also recommend using the clip limiters in most applications. See the amplifier user's manual for instructions on configuring filters and clip limiters, as well as configuring the CX 302 for stereo, parallel, or bridged mono operation.

Connecting outputs

Turn off the amplifier before opening the safety shroud over the output barrier strip or making any changes to the output connections. Always close the safety shroud when you finish working on the output connections and before turning the amplifier on. The illustrations at right will help you identify the correct output terminals for your distributed line.

Use fully insulated wiring that conforms with local and national electrical and safety codes. Wiring for circuit classes listed below are as specified by the 1999 National Electrical Code, which is prevalent in the United States. Codes in your location may vary.

25-VOLT LINE

Connect the 25-volt distributed line across the **70V** and **100V** terminals. Use wiring suitable for a Class 2 circuit.

70-VOLT LINE

Connect the 70-volt distributed line across the **COM** and **70V** terminals. Use wiring suitable for a Class 2 circuit.

100-VOLT LINE

Connect the 100-volt distributed line across the **COM** and **100V** terminals. Use wiring suitable for a Class 2 circuit.

140-VOLT LINE (BRIDGED MONO)

Connect a jumper wire between the **COM** terminals of Channel 1 and Channel 2. Connect the 140-volt distributed line across the **70V** terminals of Channel 1 and Channel 2. Use wiring suitable for a Class 3 circuit.

200-VOLT LINE (BRIDGED MONO)

Connect a jumper wire between the **COM** terminals of Channel 1 and Channel 2. Connect the 200-volt distributed line across the **100V** terminals of Channel 1 and Channel 2. Use wiring suitable for a Class 3 circuit.

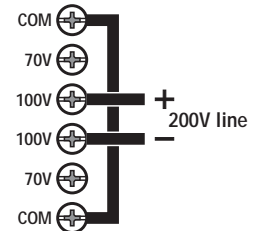
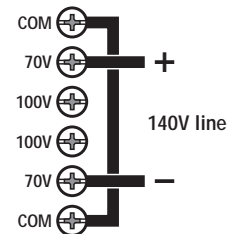
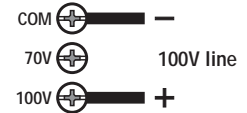
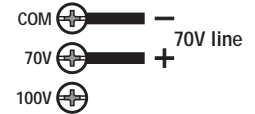
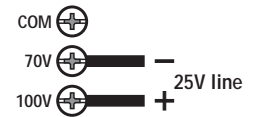

SCHEMATIC

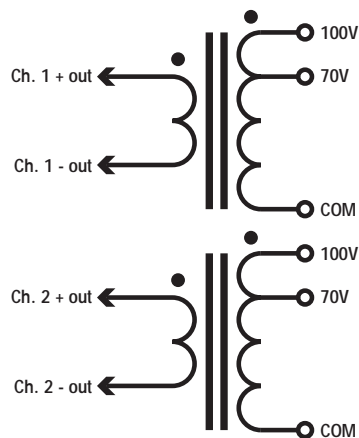

QSC Audio Products, Inc. 1675 MacArthur Blvd., Costa Mesa, California 92626 USA

Phone: (714) 754-6175 Fax: (714) 754-6174 Technical Services phone: (714) 957-7150 Technical Services fax: (714) 754-6173

www.qscaudio.com