

RANGE COMPOSITION

N 700: a range of over 100 models for the professional caterer designed to guarantee the highest level of performance, reliability, energy saving, safety standards and ergonomic operation. These concepts are reflected in the total modularity of the range that ensures numerous configurations, either free-standing or bridged. N 700 demonstrates how advanced technology can satisfy the needs of the professional caterer.

The models detailed on this sheet are electric pasta cookers: ½ and full modules in standard versions or with a built-in automatic pre-heating system (Rapid System).



178145

N 700

ELECTRIC PASTA COOKERS **ZANUSSI** PROFESSIONAL

FUNCTIONAL AND CONSTRUCTION FEATURES

- ◆ Worktop in 1,5mm stainless steel. Front panel in stainless steel with Scotch Brite finish.
- ◆ Well in 316 AISI stainless steel thus guaranteeing high resistance against the water and salt corrosive action.
- ◆ Feet in stainless steel adjustable in height 50mm.
- ◆ Easy to use control panel for power regulation and water tap.
- ◆ **Rapid System models:** control panel with switch to regulate: rapid filling, boiling, boiling and refilling with pre-heated water.
- ◆ The electrically-heated pre-heating system built into the unit (on Rapid System models, 178147), guarantees rapid temperature recovery and a production rate superior to standard models.
- ◆ Incoloy armoured heating elements positioned beneath the base of the well (standard models).

- ◆ Skimming zone for collecting and discharging, through the overflow filter, of starches and foams.
- ◆ All models have right-angled side edges to allow flush-fitting joints between units, eliminating gaps and possible dirt traps.
- ◆ Safety Thermostat avoiding the machine to work without water.
- ◆ IPX4 water protection.
- ◆ Ease of maintenance guaranteed by frontal access to all working components.
- ◆ Main connections can be via the rear or the base of the unit.

TECHNICAL DATA			
CHARACTERISTICS	MODELS		
	KCPE400 178145	KCPE800 178146	KCPE810 178147
Power supply	Electric	Electric	Electric
Water boiler			●
External dimensions - mm			
width	400	800	800
depth	700	700	700
height	850	850	850
height adjustment	50	50	50
N° of wells	1	2	1
Usable well dimensions - mm			
width	250	250	520
depth	400	400	300
height	300	300	260
Temperature limiter	●	●	
Maximum Well Capacity -lt	18, 24,5	18, 24,5	32, 40
Power - kW			
installed-electric	6	12	13
Net weight - kg.	50	50	70
Supply voltage	400 V, 3N, 50/60	400 V, 3N, 50/60	400 V, 3N, 50/60
Rapid System			●
INCLUDED ACCESSORIES			
LEFT SIDE DOOR FOR OPEN BASE CUPBOARD	1	1	1
RIGHT SIDE DOOR FOR OPEN BASE CUPBOARD		1	1

OPTIONAL ACCESSORIES			
ACCESSORIES	MODELS		
	KCPE400 178145	KCPE800 178146	KCPE810 178147
2 BASKETS 105X350 FOR PASTA COOKERS	921619	921619	
2 BASKETS 170X220 FOR PASTA COOKERS	921610	921610	
2 GN 1/2 BASKETS FOR PASTA COOKERS			927221
2 SIDE COVERING PANELS FOR TOP-D=700MM	206277	206277	206277
2 SIDE COVERING PANELS H=700 D=700	206000	206000	206000
2 SIDE KICKING STRIPS-CONCRETE INSTALL.	206265	206265	206265
3 GN 1/3 BASKETS FOR PASTA COOKERS			927214
3 ROUND BASKETS FOR PASTA COOKERS			927212
4 BASKETS 105X160 FOR PASTA COOKERS	921618	921618	
4 FEET FOR CONCRETE INSTALLATION	206210	206210	206210
4X SINGLE PORTION BASKETS			921698
6 ROUND BASKETS FOR PASTA COOKERS			927213
BASKET 350X220 FOR PASTA COOKERS	921611	921611	
CHIMNEY COVER 400MM OPEN	206284		
CHIMNEY COVER 800MM OPEN-LARGE CHIMNEY		206273	206273
CHIMNEY UPSTAND 400MM	206303		
CHIMNEY UPSTAND 800MM		206304	206304
FALSE BOTTOM FOR 40L PASTA COOKER BASKET			206238
FLANGED FEET KIT	206136	206136	206136
FRONT.KICK.STRIP F.CONCRETE INST.1000 MM	206150	206150	206150
FRONT.KICK.STRIP F.CONCRETE INST.1200 MM	206151	206151	206151
FRONT.KICK.STRIP F.CONCRETE INST.1600 MM	206152	206152	206152
FRONT.KICK.STRIP F.CONCRETE INST.200 MM	206146	206146	206146
FRONT.KICK.STRIP F.CONCRETE INST.400 MM	206147	206147	206147
FRONT.KICK.STRIP F.CONCRETE INST.800 MM	206148	206148	206148
FRONTAL HANDRAIL 1200 MM	206191	206191	206191
FRONTAL HANDRAIL 1600 MM	206192	206192	206192
FRONTAL HANDRAIL 400 MM	206166	206166	206166
FRONTAL HANDRAIL 800 MM	206167	206167	206167
FRONTAL KICKING STRIP 1000 MM	206177	206177	206177
FRONTAL KICKING STRIP 1200 MM	206178	206178	206178
FRONTAL KICKING STRIP 1600 MM	206179	206179	206179
FRONTAL KICKING STRIP 200 MM	206174	206174	206174
FRONTAL KICKING STRIP 400 MM	206175	206175	206175
FRONTAL KICKING STRIP 800 MM	206176	206176	206176
GRID SUPPORT FOR ROUND BASKETS			927219
LARGE HANDRAIL(PORTIONING SHELF)400 MM	206185	206185	206185
LARGE HANDRAIL(PORTIONING SHELF)800 MM	206186	206186	206186
LID FOR 40LT PASTA COOKER 700 LINE			927218
LID FOR PASTA COOKERS	921607	921607	
PAIR OF SIDE KICKING STRIPS	206249	206249	206249
RIGHT AND LEFT SIDE HANDRAILS	206240	206240	206240
RIGHT SIDE DOOR FOR OPEN BASE CUPBOARD	206194		
SUPPORT FOR 4 PASTA COOKER BASKETS	921606	921606	
WATER COLUMN EXTENSION FOR 700 LINE	206291	206291	206291
WATER COLUMN WITH SWIVEL ARM	206289	206289	206289



www.zanussiprofessional.com

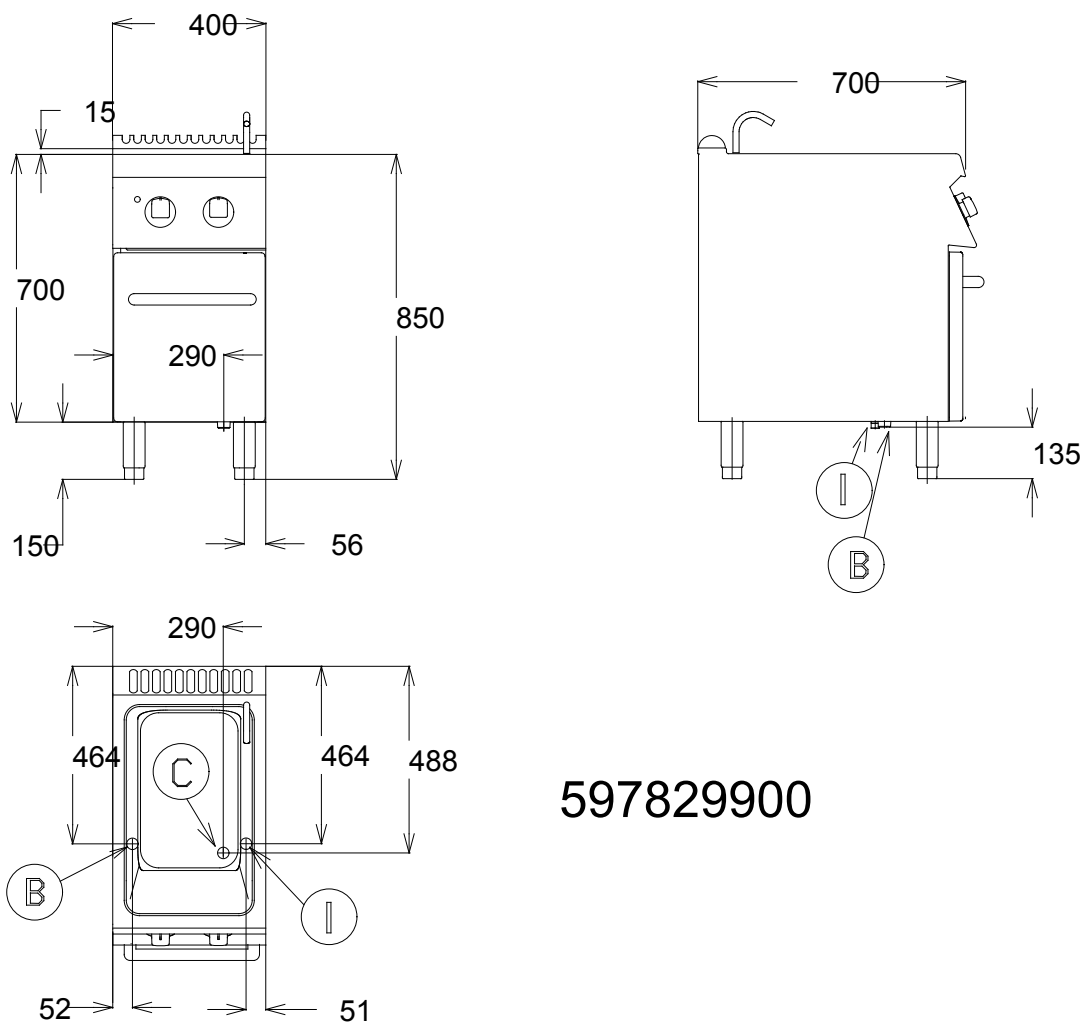

597829900

LEGEND

	KCPE400 178145
B - Cold water inlet	1/2"
C - Water drain	1"
I - Electrical connection	400 V, 3N, 50/60



www.zanussiprofessional.com

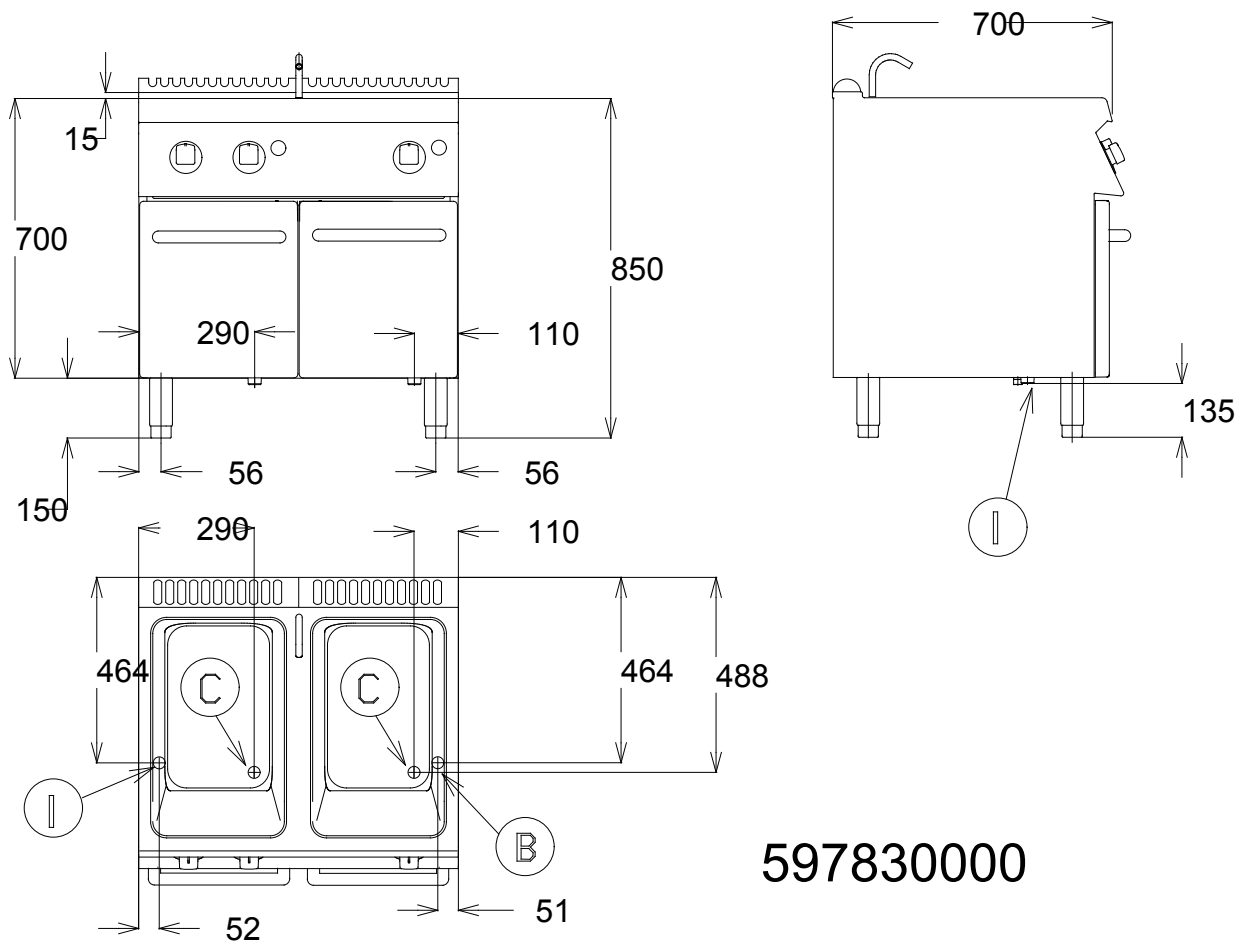

597830000

LEGEND

	KCPE800 178146
B - Cold water inlet	1/2"
C - Water drain	1"
I - Electrical connection	400 V, 3N, 50/60



www.zanussiprofessional.com

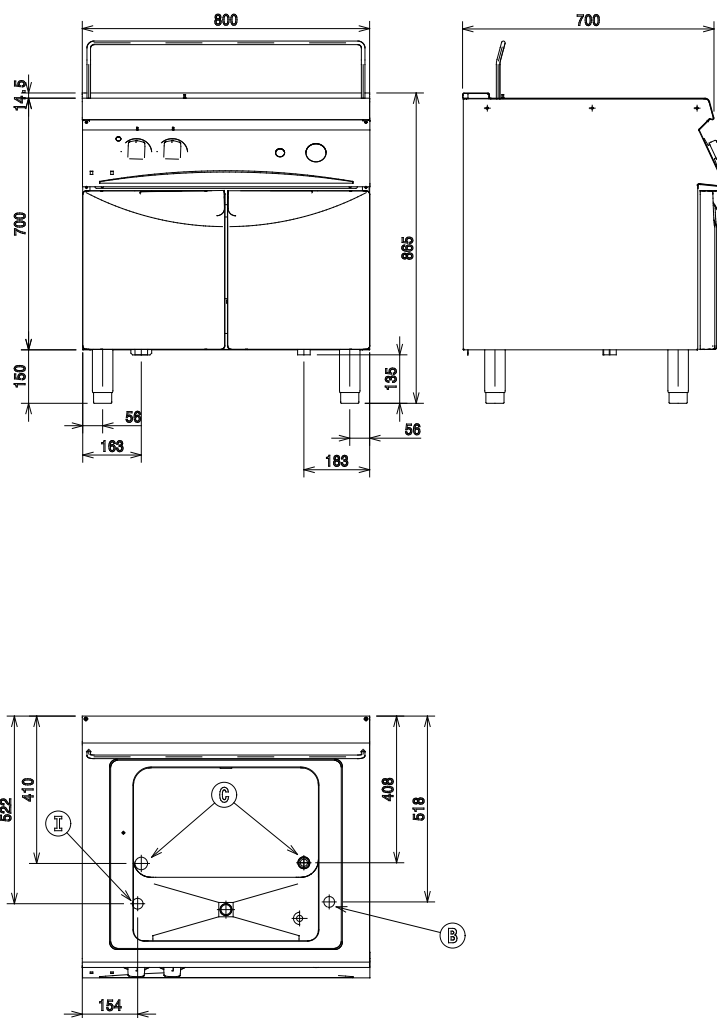

LEGEND

	KCPE810 178147
B - Cold water inlet	1/2"
C - Water drain	1"
I - Electrical connection	400 V, 3N, 50/60



www.zanussiprofessional.com