



The Intrepid Multi-Fuel Heater*

Model 1695

Homeowner's
Installation
and Operating
Manual

SAFETY NOTICE: IF THIS APPLIANCE IS NOT PROPERLY INSTALLED, OPERATED AND MAINTAINED, A HOUSE FIRE MAY RESULT. TO REDUCE THE RISK OF FIRE, FOLLOW THE INSTALLATION INSTRUCTIONS. FAILURE TO FOLLOW INSTRUCTIONS MAY RESULT IN PROPERTY DAMAGE, BODILY INJURY OR EVEN DEATH. CONTACT LOCAL BUILDING OFFICIALS ABOUT RESTRICTIONS AND INSTALLATION INSPECTION REQUIREMENTS IN YOUR AREA.



We recommend that our woodburning hearth products be installed and serviced by professionals who are certified in the U.S. by the National Fireplace Institute® (NFI) as NFI Woodburning Specialists or who are certified in Canada by Wood Energy Technical Training (WETT).



*The models outlined in these installation instructions are for export outside of North America.

Do Not Discard This Manual: Retain for Future Use

Welcome

Congratulations on your choice of a Vermont Castings Intrepid Multi-Fuel Heater. With this purchase, you made a commitment to make the hearth a place of warmth, beauty and comfort in your home. At Vermont Castings we share that joy and appreciation for the hearth, and we show it in all our cast-iron stoves and fireplaces.

As you become acquainted with your new stove, you will find the aesthetic appeal of cast iron is matched by its superb capacity to absorb and radiate heat.

Also, Vermont Castings products are among the cleanest-burning wood stoves and fireplaces available today. And, as an owner of a Vermont Castings stove, you are making a strong statement for pollution-free energy. But clean burning depends on both the manufacturer and the operator. Please read this manual carefully to understand how to properly operate your stove.

At Vermont Castings, we are equally committed to your satisfaction as a customer and that is why we maintain an exclusive network of the finest dealers in the industry. Chosen for their expertise and dedication to customer service, our dealers are factory-trained and know each Vermont Castings products in detail. Feel free to contact your Authorized Vermont Castings Dealer anytime you have question about your stove or its performance.

We have built your Intrepid Multi-fuel stove with the utmost care. With normal use and proper care, it will provide you with many years of service.

This manual contains valuable instructions on the installation and operation of your Vermont Castings stove. You will also find useful information on assembly and maintenance procedures. We urge you to read the manual thoroughly and to keep it as a reference.

Sincerely,

All of us at CFM Corporation

Save These Instructions For Future Reference

Table of Contents

Specifications	3
Installation	4
Clearance Charts.....	13
Assembly	17
Operation	18
Draft Management.....	22
Maintenance	25
Parts List.....	29

Ask your Vermont Castings dealer how these installation accessories can enhance the versatility, appearance, and safety of your Intrepid Stove.

- Bottom Heat Shield
- Rear Heat Shield
- Chimney connector heat shields
- Heavy-gauge enamel pipe to match the stove's color
- Warming shelves, in plain black or matching enamel colors
- Spark screen for open-fireplace use
- Short legs
- Outside air kit
- Mobile-home kit.

Proposition 65 Warning: Fuels used in gas, wood-burning or oil fired appliances, and the products of combustion of such fuels, contain chemicals known to the State of California to cause cancer, birth defects and other reproductive harm.

California Health & Safety Code Sec. 25249.6

Specifications

Intrepid Multi-Fuel, Model 1695, 1696, 1697

Range of heat output.....	2.42 kw - 7.83 kw ¹
Maximum heat output.....	7.3 kw ¹
Area heated.....	Up to 1000 sq. ft. (92 sq. m) ²
Fuel size/type.....	16" (406 mm) logs
Loading.....	Front or Top
Chimney Connector.....	6" (152 mm) diameter
Chimney Flue size.....	6" (152 mm) minimum
Flue exit position.....	Reversible, top or rear
Primary air ...	Manually set, thermostatically maintained
Ash handling system.....	Removable ash pan
Glass panels.....	High-temperature ceramic
Weight.....	223 lbs. (101kg)
Width (leg to leg).....	21½" (546 mm)
Depth (leg to leg).....	13¾" (349 mm)
Height to top of flue collar	
With regular legs.....	25" (635 mm) top exit
.....	24" (610 mm) rear exit
With optional short legs.....	21" (533 mm) top exit
.....	19¾" (502 mm) rear exit

¹ this value can vary depending on how the stove is operated, the type and moisture content of the fuel used, as well as the design, construction, and climatic location of your home. Figures shown are based on maximum fuel consumption obtained under laboratory conditions and on average efficiencies.

² These values are based on operation in building code-conforming homes under typical winter climate conditions in New England. If your home is of nonstandard construction (e.g., unusually well-insulated, not insulated, built underground, etc.) or if you live in a more severe or more temperate climate, these figures may not apply. Since so many variables affect performance, consult your Vermont Castings Company authorized dealer to determine realistic expectations for your home.

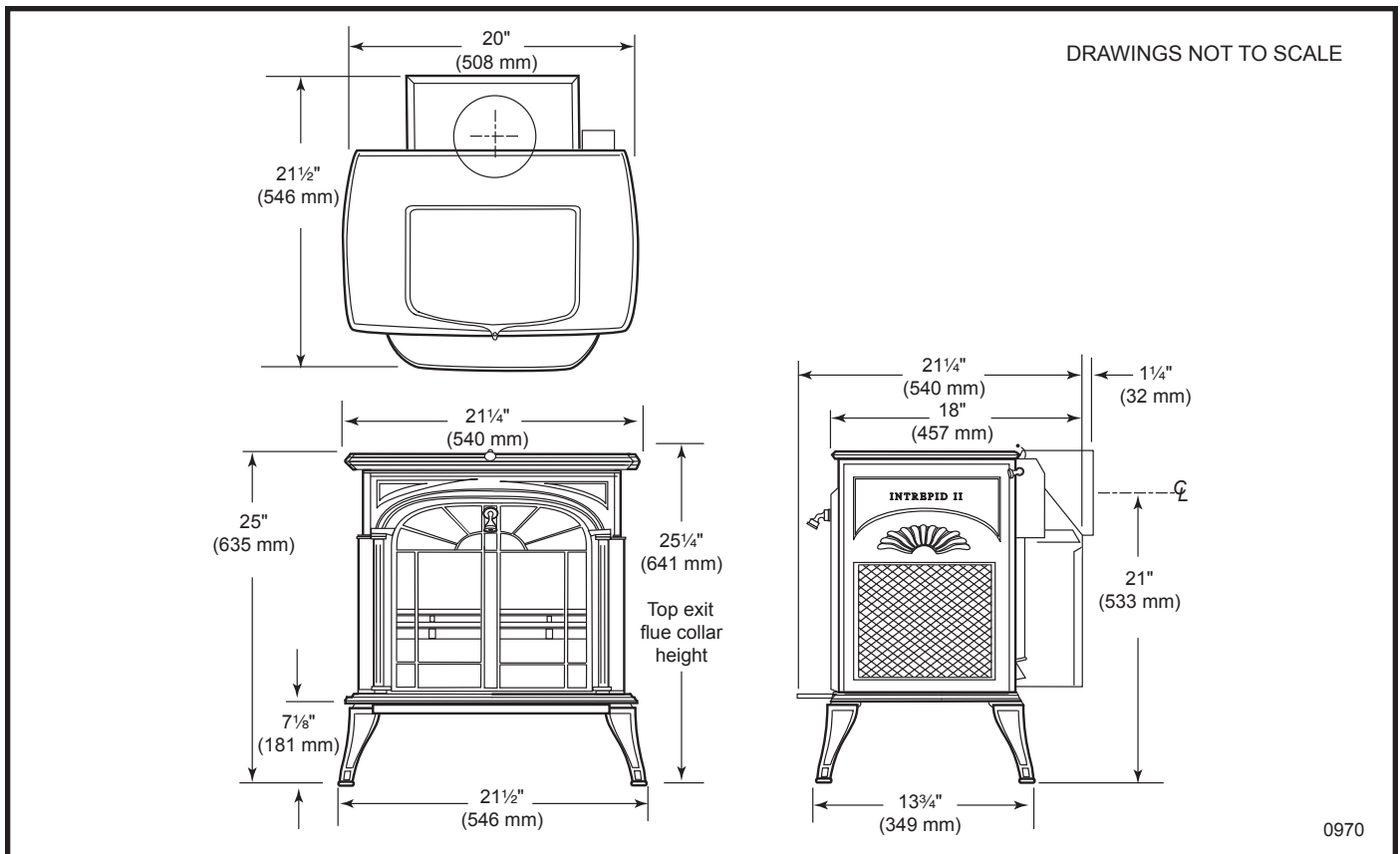

Fig. 1 Intrepid Multi-fuel Heater dimensions.

Installation

SAFETY NOTICE: IF YOUR STOVE IS NOT PROPERLY INSTALLED, A HOUSE FIRE MAY RESULT. TO REDUCE THE RISK OF FIRE, FOLLOW THE INSTALLATION INSTRUCTIONS. CONTACT LOCAL BUILDING OR FIRE OFFICIALS ABOUT RESTRICTIONS AND INSTALLATION INSPECTION REQUIREMENTS IN YOUR AREA.

Before you begin an installation, review your plans to see that:

- Your stove and chimney connector will be far enough from combustible material to meet all clearance requirements.
- The floor protector is large enough and is constructed properly to meet all requirements.
- You have all necessary permits from local authorities.

Your local building official is the final authority for approving your installation as safe and determining that it meets local and state codes.

The metal label permanently attached to the back of every Vermont Castings stove indicates that the stove has been tested to current ULC standards, and gives the name of the testing laboratory. Clearance and installation information also is printed on the label. When the stove is installed according to the information both on the label and in this manual, local authorities in most cases will accept the label as evidence that the installation meets codes and can be approved.

However, codes vary in different areas. Before starting the installation, review your plans with the local building authority. Your local dealer can provide any additional information needed.

For any unresolved installation issues, refer to CSA CAN-B365 Installation Code for Solid Fuel Burning Appliances and Equipment. These standards are the basis for many national codes. They are nationally recognized and are accepted by most local authorities. Your local dealer or your local building official may have a copy of these regulations.

IMPORTANT: FAILURE TO FOLLOW THESE INSTALLATION INSTRUCTIONS MAY RESULT IN A DANGEROUS SITUATION, INCLUDING A CHIMNEY OR HOUSE FIRE. FOLLOW ALL INSTRUCTIONS EXACTLY, AND DO NOT ALLOW MAKESHIFT COMPROMISES TO ENDANGER PROPERTY AND PERSONAL SAFETY.

Outside Air

In some modern, super-insulated homes, there is not enough air for combustion because of insufficient air infiltration into the building. Such air enters a home through unsealed cracks and openings. Kitchen or bath exhaust fans can compete with the stove for available air and compound the problem.

When poor draft is caused by a low infiltration rate, opening a ground floor window on the windward side of the house and in the vicinity of the stove will usually alleviate the problem.

Another solution is to install a permanent outside air supply to the stove and/or room. In some areas, in fact, bringing air for combustion from outside the home directly to the air inlet of the stove is required for new construction.

An outside air supply is not affected by pressure variations within the house, and improved stove performance often results. An Outside Air Adapter Kit #33258 for the Intrepid II is available from your local Vermont Castings dealer.

What Kind of Chimney to Use

Your Intrepid Multi-fuel must be connected to a code-approved masonry chimney with a flue liner, to a relined masonry chimney that meets local codes, or to a prefabricated metal chimney that complies with the requirements for Type HT chimneys in the Standard for Chimneys, Factory-Built, Residential Type and Building Heating Appliance, UL 103, or the High Temperature (650°C) Standard ULC S-629 for Canada. Whatever kind you use, the chimney and chimney connector must be in good condition and kept clean. Figure 2 shows the two chimney types.

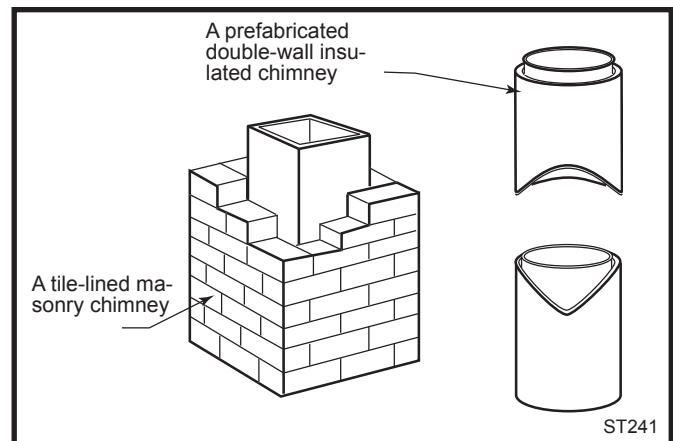

Fig. 2 Standard chimney types.

If you use an existing masonry chimney, it must be inspected to ensure safe condition before the stove is installed. Your local professional chimney sweep, building inspector, or fire department official will be able to inspect the chimney or provide a referral to someone who can.

The chimney must extend at least 3' (914 mm) above the highest point where it passes through a roof, and at least 2' (610 mm) higher than any portion of a building within 10' (3 m). (Fig. 3)

For proper draft and good performance, any chimney used with an Intrepid II should extend at least 16' (5 m) above the flue collar of the stove.

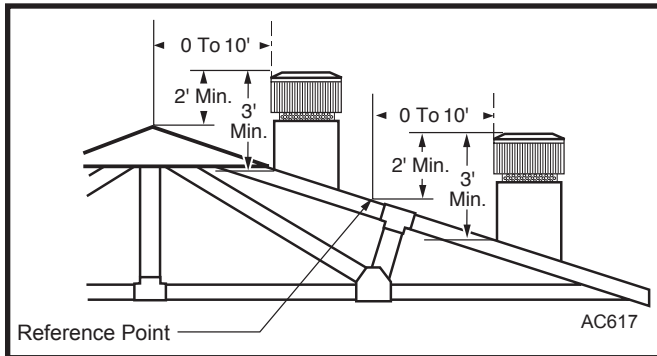

Fig. 3 The 2'-3'-10' Chimney Rule.

Masonry Chimneys

An inspection of the chimney must confirm that it has a lining. Do not use an unlined chimney. The chimney should have no cracks, loose mortar, other signs of deterioration, or blockage. Repair any defects before using the chimney with your stove.

Seal any unused openings in an existing masonry chimney with masonry to the thickness of the chimney wall, and repair the chimney liner. Openings sealed with pie plates or wallpaper are a hazard; seal them with mortar or refractory cement. In the event of a chimney fire, flames and smoke may be forced out of these unused thimbles.

The chimney should be thoroughly cleaned before use.

A newly-built masonry chimney must conform to the standards of your local building code or, in the absence of a local code, to a recognized national code. Masonry chimneys must be lined, either with code-approved masonry or precast refractory tiles, stainless steel pipe, or a code-approved, "poured-in-place" liner. The chimney's clean-out door must seal tightly.

Prefabricated Chimneys

A prefabricated metal chimney must be one recognized for use with solid-fuel burning appliances.

DO NOT CONNECT THIS UNIT TO A CHIMNEY FLUE SERVING ANOTHER APPLIANCE.

Chimney Size

An Intrepid Multi-fuel is approved for venting into a masonry chimney with a nominal flue size of 8" x 8" (200 x 200 mm), and into a round flue size of 6" (150 mm).

It may not be vented into larger chimneys without a liner to reduce the effective flue size to 6" (150mm) diameter. Larger chimneys must have their flues relined for proper stove performance.

Accessories to make the connection between stainless steel chimney liners and your Intrepid II are available through your local dealer.

Chimney Connector Guidelines

Chimney connector is the double-wall or single-wall pipe that connects the stove to the chimney. The chimney is a masonry or prefabricated structure that encloses the flue. Chimney connectors are used only to make the connection from the stove to the chimney.

Double-wall chimney connectors must be tested and listed for use with solid-fuel burning appliances. Single-wall chimney connectors should be made of 24 gauge or heavier steel, and should be 6" (150 mm) in diameter. Do not use galvanized connector; it cannot withstand the high temperatures that can be reached by smoke and gases, and may release toxic fumes under high heat.

If possible, do not pass the chimney connector through a combustible wall or ceiling. If passage through a combustible wall is unavoidable, refer to the section following on Wall Pass-Throughs. Do not pass the chimney connector through an attic, a closet, or any similar concealed space. The whole connector should be exposed and accessible for inspection and cleaning.

Keep the horizontal run of chimney connector as short and direct as possible, with no more than one 45 degree elbow. The maximum total length of chimney connector should not exceed 8 feet.

In cathedral ceiling installations, extend the prefabricated chimney down to within 8 feet (2.5 m) of the stove.

SAFETY NOTE: ALWAYS WEAR GLOVES AND PROTECTIVE EYEWEAR WHEN DRILLING, CUTTING OR JOINING SECTIONS OF CHIMNEY CONNECTOR.

Double-wall Chimney Connector

Information on assembling and installing double-wall connector is provided by the manufacturer of the double-wall pipe. Follow the manufacturer's instructions exactly as you assemble the connector and attach it to the stove and chimney. Using connectors and chimneys from the same manufacturer makes the assembly and installation straightforward.

NOTE: For installations using double-wall connectors, minimum clearances must conform to the listed clearances in the clearance chart on Page 13.

Single-wall Chimney Connector

- Beginning at the flue collar of the stove, assemble the chimney connector. Insert the first crimped end into the stove's flue collar, and keep each crimped end pointing toward the stove. Using the holes in the flue collar as guides, drill 1/8" (3 mm) holes in the bottom of the first section of chimney connector and secure it to the flue collar with three #10 x 1/2" sheet metal screws.

- Secure each joint between sections of chimney connector, including telescoping joints, with at least three sheet metal screws. The predrilled holes in the top of each section of chimney connector serve as guides when you drill 1/8" (3 mm) holes in the bottom of the next section.

- Secure the chimney connector to the chimney.

Instructions for various installations follow.

- Be sure the installed stove and chimney connector are correct distances from nearby combustible material.

NOTE: Special slip pipes and thimble sleeves that form telescoping joints between sections of chimney connector are available to simplify installations. They often eliminate the need to cut individual connector sections. Consult your local dealer about these special pieces.

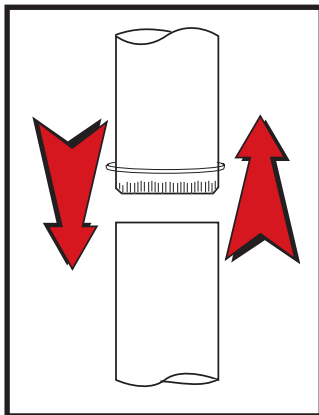

Fig. 4 The crimped end of the connector points toward stove.

Securing the Single-wall Connector to a Prefabricated Chimney

For prefabricated chimneys, follow the installation instructions of the chimney maker exactly as you install the chimney. The maker of the chimney will supply the accessories to support the chimney, either from the roof of the house, at the ceiling of the room where the stove is installed, or from an exterior wall.

Special adaptors are available from your local dealer to make the connection between the prefabricated chimney and the chimney connector. The top of such adaptors attaches directly to the chimney or to the chimney's ceiling support package, while the bottom of the adaptor is screwed to the chimney connector.

These adaptors are designed so the top end will fit outside the inner wall of the chimney, and the bottom end will fit inside the first section of chimney connector. When assembled in this way, any soot or creosote falling from the inner walls of the chimney will stay inside the chimney connector.

Securing the Single-wall Connector to a Masonry Chimney

For masonry chimneys, both freestanding and fireplace chimneys may be used for installation of your Intrepid Multi-fuel.

Freestanding Chimney Installations

If the chimney connector must pass through a combustible wall to reach the chimney, follow the recommendations in the Wall Pass-through section that follows.

The opening through the chimney wall to the flue (the "breach") must be lined with either a ceramic or metal cylinder, called the "thimble", which is cemented firmly in place. The fit must be snug and the joint between the thimble and the chimney wall must be cemented. (Fig. 6)

A special piece called the "thimble sleeve," slightly smaller in diameter than standard connector and most thimbles, will facilitate the removal of the chimney connector system for inspection and cleaning. Thimble sleeves should be available from your local dealer. (Fig. 5)

To install a thimble sleeve, slide it into the breach until it is flush with the inner flue wall. Do not extend it into the actual flue passage, as this could interfere with the draft.

The thimble sleeve should protrude 1-2" (25-50 mm) into the room. Use furnace cement and thin gasketing to seal the sleeve in place in the thimble. Secure the chimney connector to the outer end of the sleeve with sheet metal screws.

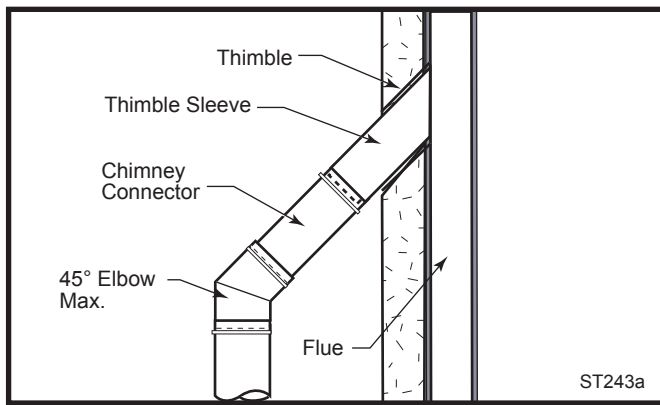

Fig. 5 The thimble, made of either ceramic or metal, must be cemented securely in place.

Without a thimble, a suitable length of chimney connector can be extended through the breach to the inner face of the flue liner, and cemented securely in place. Additional pieces of connector are then attached with sheet metal screws.

Fireplace Chimney Installations - Above a Fireplace

The Intrepid Multi-fuel may be connected to a chimney above a fireplace opening also. In such installations, the stove is positioned on the hearth in front of the fireplace and the chimney connector rises from the stove top and then angles 45° back into the chimney. (Fig. 6)

The chimney liner should extend to the point at which the chimney connector enters the chimney.

If the chimney connector from your installation enters the chimney above a fireplace, follow all the guidelines mentioned above for freestanding installations. In addition, give special consideration to the following points:

- Check the clearance between the stove and the chimney connector, and any combustible trim or the mantel. Use the necessary combination of mantel, trim, and connector heat shields to achieve the required clearances.
- Check the clearance between the chimney connector and the ceiling. If no heat shields are used, the clearance should be at least 26" (660 mm). To find out how much this clearance may be reduced with heat shields, see the clearance chart on Page 13.
- The fireplace damper must be sealed to prevent room air from escaping up the flue. However, it must be possible to reopen the damper to inspect or clean the chimney.

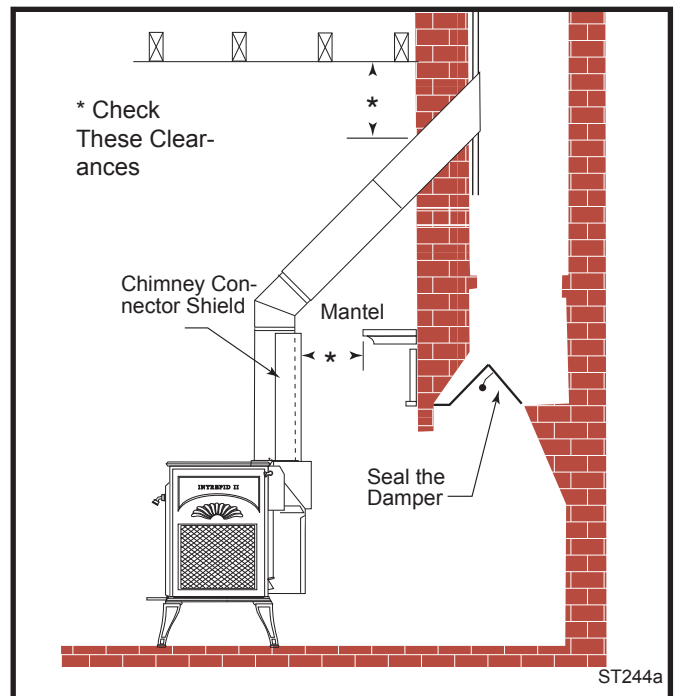

Fig. 6 Chimney connector enters chimney above the fireplace.

Fireplace Chimney Installations - Through a Fireplace

If your fireplace height is at least 25" (635 mm), you may install an Intrepid Multi-fuel with standard legs through the fireplace opening using a 90° Tee kit available from your local dealer. This positive connection kit ensures a tight fit between the stove flue collar and the chimney flue. (Fig. 7)

Fireplace installations, whether connected to the flue above or through the fireplace opening, have special clearance requirements to adjacent trim and the mantel. You will find the required clearances for the Intrepid Multi-fuel fireplace installations on Page 13.

Floor protection requirements also apply to fireplace installations. Floor protection information is on Page 9.

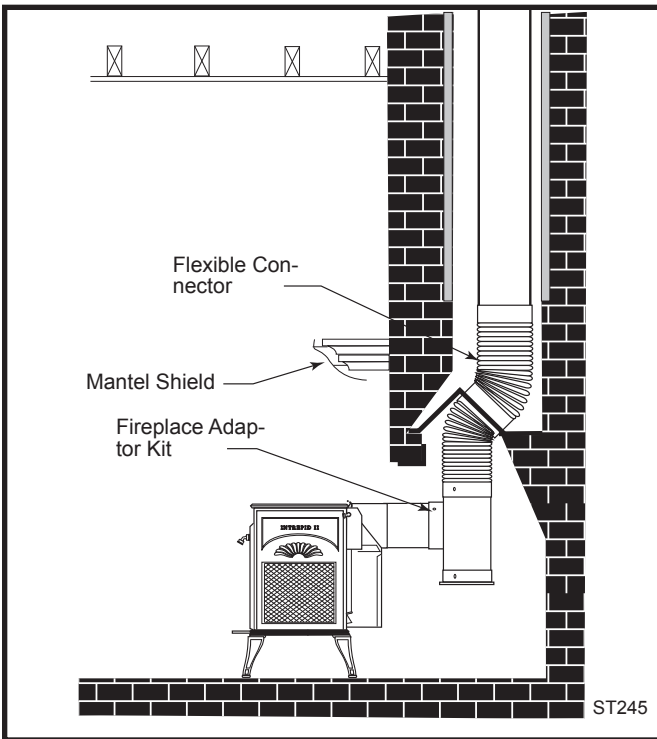

Fig. 7 Chimney connector enters chimney through the fireplace opening.

Wall Pass-Throughs

Whenever possible, design your installation so that the connector does not pass through a combustible wall. If you are considering a wall pass-through in your installation, check with your building inspector before you begin. Also, check with the chimney connector manufacturer for any specific requirements.

Accessories are available for use as wall pass-throughs. If using one of these, make sure it has been tested and listed for use as a wall pass-through.

Always adhere to local building codes when installing a wall pass-through. Figure 8 shows one recommended method.

All combustible material in the wall must be removed around the single-wall connector to provide clearance that is three times the pipe diameter. Any material used to enclose the opening must be noncombustible.

Figure 9 shows an alternate method in which all combustible material in the wall is cut away to provide the required clearance that is three times the pipe diameter. The resulting space must remain empty. A flush-mounted sheet metal cover may be used on one side only. If covers must be used on both sides, each cover must be mounted on noncombustible spacers at least 1" (25 mm) clear of the wall.

NOTE: Do not vent your Intrepid Multi-fuel into a factory-built (zero-clearance) fireplace. These appliances and their chimneys are specifically designed as a unit for use as fireplaces. It may void the listing or be hazardous to adapt them for any other use.

DO NOT CONNECT AN INTREPID MULTI-FUEL TO ANY AIR DISTRIBUTION DUCT OR SYSTEM.

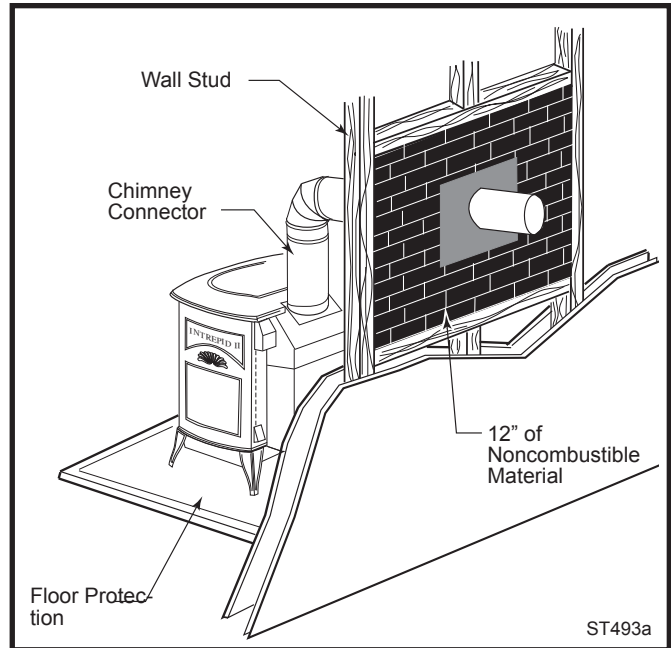

Fig. 8 An approved wall pass-through for the United States.

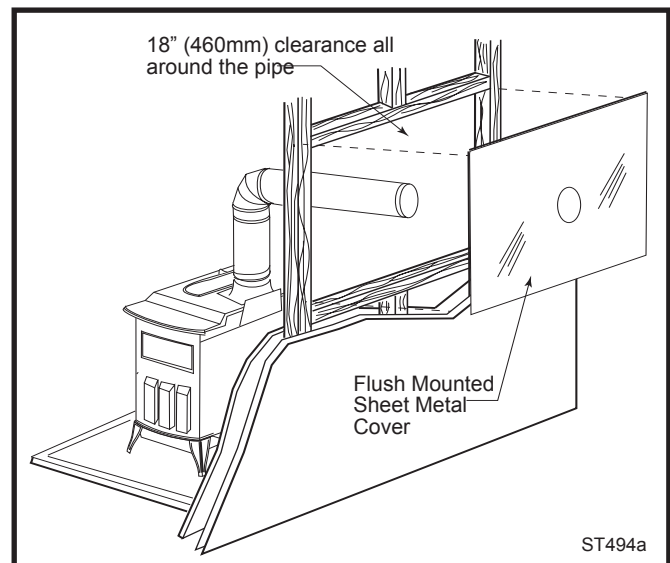

Fig. 9 An approved wall pass-through for Canada.

Floor Protection

Specifications herein are primarily for common timber frame construction.

The floor beneath the stove requires protection from radiant heat and direct contact with sparks or embers.

Heat protection is provided by a Vermont Castings Bottom Heat Shield, part #0307.

Spark and ember protection is provided by a floor protector, which may be any noncombustible material. Consult your local building code for floor protection size and composition. Figure 9 indicates specifications for the U.S. and Canada.

For new hearth construction specifications and requirements, refer to your local building codes.

When using brick, tile, or stone, individual pieces must be mortared so sparks cannot fall through.

Floor protection also must extend under the chimney connector and 2" to either side ('C', Fig. 10) For 6" (150mm) connector used with the Intrepid Multi-Fuel, the protector must be a minimum of 10" (250mm) wide, centered under the connector.

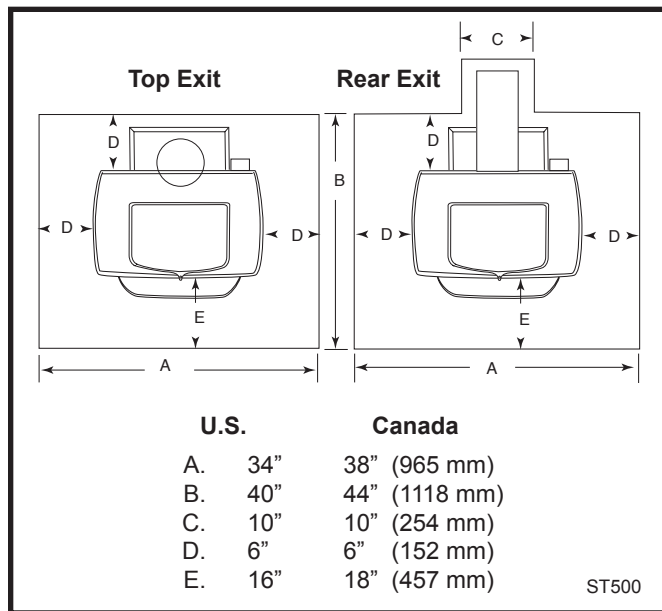

Fig. 10 Required floor protector dimensions.

Floor Protection for Fireplace Installations

Do not assume your fireplace hearth is completely noncombustible.

Many fireplace hearths do not satisfy the "completely noncombustible" requirement because the brick or concrete in front of the fireplace opening is supported by heavy wood framing as in Figure 11. Because heat passes through brick or concrete readily, it can easily pass through to the wood. As a result, such fireplace

hearths can be a fire hazard and are considered a combustible floor.

Keep in mind that many raised hearths will extend less than the required clearance from the front of the heater when it is installed. In such cases, sufficient floor protection as described above must be added in front of the hearth to satisfy the minimum floor protector requirement from the front of the stove. Fireplace hearths must also offer the required protection of 6" (152 mm) on either side.

Optional 3" (75 mm) short legs may be used only on such hearths that meet the width and depth requirements outlined previously under "floor protection."

Hearth rugs do not satisfy the requirements for floor protection.

Fireplace installations also have special clearance requirements to the side walls, side decorative trim, and fireplace mantel. Refer to the information on fireplace and mantel trim shields in this section.

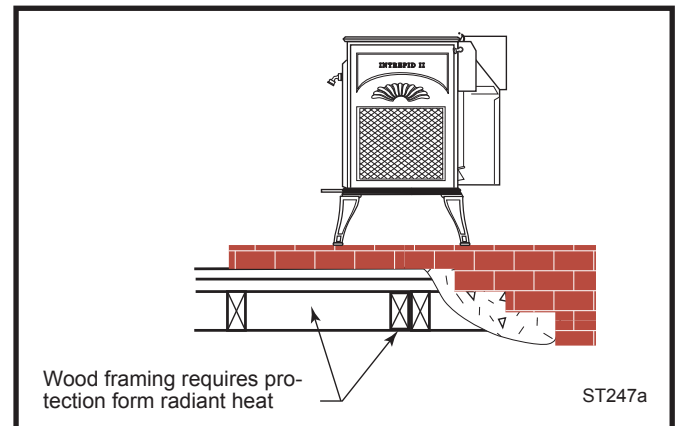

Fig. 11 Supporting timbers under fireplace hearth are considered to be combustible.

Keep the Stove and Connector a Safe Distance from Surrounding Materials

Specifications herein are primarily related to common timberframe construction. Both a stove and its chimney connector radiate heat in all directions when operating, and dangerous overheating of nearby combustible materials can occur if they are too close to the heat. A safe installation requires that adequate clearance be maintained between the hot stove and its connector and nearby combustibles.

Clearance is the distance between either your stove (measured from the back edge of the stove's top plate) or chimney connector, and nearby walls, floors, the ceiling, and any other fixed combustible surface. Your stove has special clearance requirements that have been established after careful research and testing. These clearance requirements must be strictly observed.

In addition, furnishings and other combustible materials must be kept away from the stove as well. In general, a distance of 48" (1220 mm) must be maintained between the stove and moveable combustible items such as drying clothes, furniture, newspapers, firewood, etc. Keeping those clearance areas empty assures that nearby surfaces and objects will not overheat.

Reducing Clearances

Stove clearances may be reduced by using heat shields attached to the stove. Chimney connector clearances may be reduced by using heat shields on single-wall connector, or by using double-wall connector. Clearances may also be reduced by using wall shields. All shielding used to reduce clearances must be listed by a recognized testing laboratory and approved by the local regulatory body.

Clearance requirements are established for many different installations. In general, the greatest clearance is required when you are placing a stove and its connector with no heat shields near a wall with no heat shield.

For example, when the Intrepid Multi-Fuel is installed parallel to the rear wall and no shielding is used, it must be at least 30" (760 mm) from the wall behind it and at least 24" (610 mm) from walls on either side.

If the Intrepid Multi-Fuel is installed in a corner and no shields are used, the corners of the stove must be at least 20" (510 mm) from nearby walls.

The least clearance is required when both the stove and its connector, as well as the wall, have heat shields.

When shields are attached to the stove or chimney connector, they are mounted 1" - 2" (25-50mm) away from the stove or connector surface on noncombustible spacers. Air flowing between the stove (and/or chimney connector) and nearby shields carries heat away. Do not block the air flow by filling this empty space with any insulating material.

The shiny surface facing the heat source must be left unpainted, enabling heat to reflect back towards the stove or connector and away from the wall. Shields are never used on double-wall connectors.

Clearances may be reduced only by means approved by the regulatory authority, and in accordance with the clearances listed in this manual.

Because of their restricted air flow and heat retention characteristics, specific construction requirements and special clearances apply to installations into alcoves. Refer to the diagrams on Page 12, and contact your Vermont Castings dealer for details before beginning an alcove installation.

Stove Heat Shields

The Vermont Castings Intrepid Multi-Fuel Rear Heat Shield is one way to reduce the clearance to the rear wall. The rear heat shield may be installed on either rear- or top-exiting stoves. However, since the chimney connector also radiates heat toward the wall in top-exiting installations, either single-wall connector with connector heat shields, or listed and approved double-wall chimney connector should be used whenever the rear heat shield is used on top-exiting stoves.

Clearance reductions with the rear heat shield apply only to the wall to the rear in parallel installations. Neither the side clearance requirement nor the clearance requirement in corner installations may be reduced.

Wall Shields

Clearances may be reduced by using a wall shield constructed of 24 gauge or heavier sheet metal, or of another noncombustible material such as 1/2" (13 mm) insulation board or common brick "laid on flat," with the 3 1/2" (90 mm) side down. Figure 12 shows such a wall shield.

Shields must be spaced out from the combustible surface 1" (25 mm) on noncombustible spacers. The spacers should not be directly behind the stove or chimney connector.

Air must be able to flow between the wall and the shield. At least 50% of the bottom 1" (25 mm) of the shield should be open and the shield must be open at the top. (Fig. 12)

The wall shield for a stove must extend 10" (250 mm) above the top of the stove, or a height of 35" (890 mm). The wall shield for the chimney connector must be 28" (710 mm) wide, centered behind the connector; for installations that use an approved prefabricated chimney to pass through the ceiling, the chimney connector shield used with single-wall connector must stop 1" (25 mm) below the ceiling.

Chimney Connector Clearance Reductions

Chimney connector clearances may be reduced by using heat shields on single-wall connector or by using double-wall connector. One of these methods should be used whenever the rear heat shield is used in top-exit installations, or in any other situation when it is necessary to protect nearby combustibles from the heat of the chimney connector. The ceiling above horizontal runs of chimney connector must be protected as well if the clearance is inadequate. Refer to the Clearance Charts.

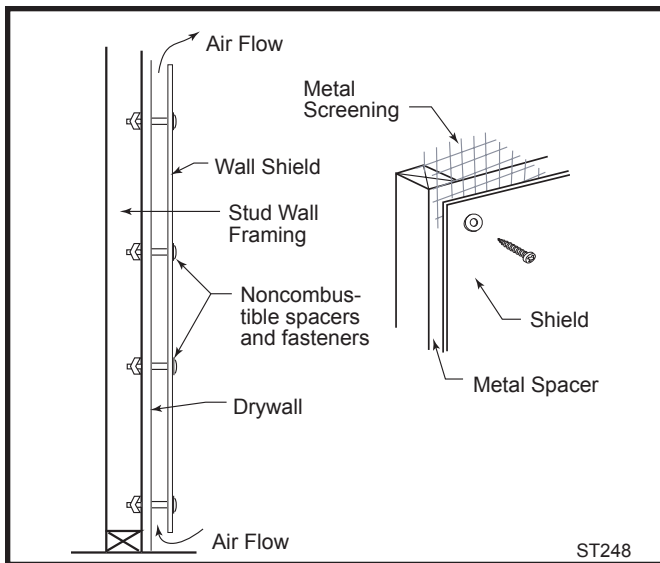

Fig. 12 Approved wall shield construction.

In top-exiting installations in which the single-wall connector extends to the ceiling and connects to a prefabricated insulated metal chimney, the connector shield must extend to within an inch of the ceiling. A ceiling heat shield must be installed that is 22" (560 mm) in diameter and, as explained above, that extends 1" (25 mm) below the ceiling. The ceiling shield must be constructed of 24 gauge or heavier sheet metal, must be centered on the chimney, and must meet any wall protector that is also a part of the installation.

The Intrepid Multi-Fuel has not been tested with double-wall connectors and wall heat shielding. **Maintain 12" (305 mm) clearance around double-wall chimney connectors. No further clearance reduction is permitted.**

Fireplace and Mantel Trim Shields

A fireplace installation requires special clearance between the side of the stove and the right and left walls, between the side of the stove and the decorative side trim on the fireplace face, and between the top of the stove and the mantel.

Noncombustible shields installed 1" (25 mm) away from the combustible surface on noncombustible spacers, called ventilated shields, may be used to reduce clearances. (Fig. 13)

To protect a mantel from the heat of an Intrepid Multi-fuel in a fireplace installation, the ventilated mantel shield must be at least 48" (1219 mm) long, and it must be centered over the stove. Ventilating shields for side trim must extend the full length of the trim.

An unprotected mantel ('A', Fig. 14) cannot be more than 9" (229 mm) deep and must have a minimum clearance of 30" (762 mm), measured from the stove's top plate. With a ventilated shield, (Fig. 13) this clearance may be reduced safely to 14" (356 mm).

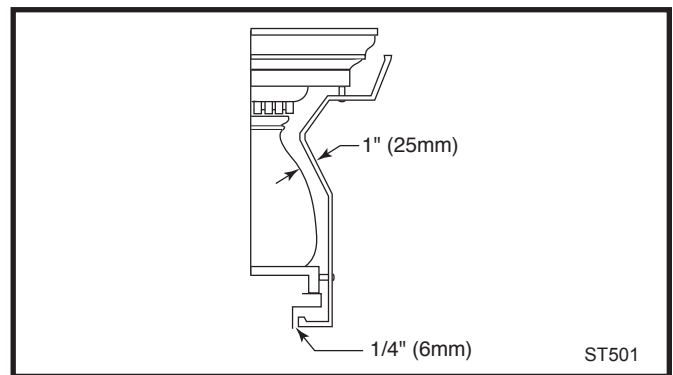
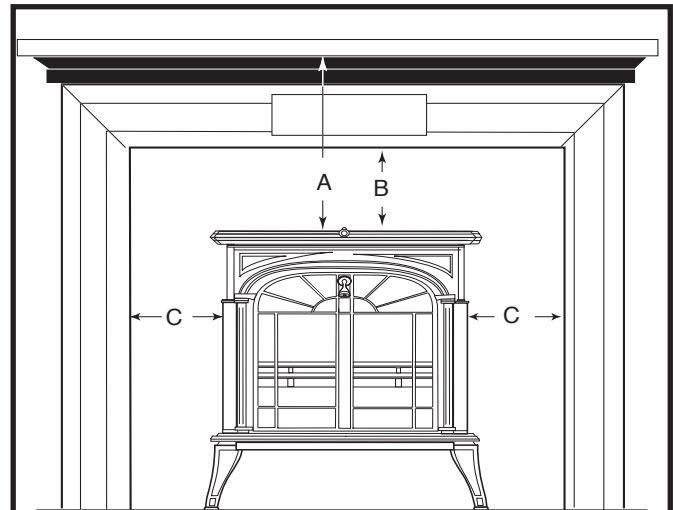

Fig. 13 A custom-formed mantel shield.



Fireplace Mantel and Trim Clearances

Measured from the top and sides of the stove

	Unprotected	Protected
A. Mantel	30" (762 mm)	14" (356 mm)
B. Top Trim	24" (610 mm)	14" (356 mm)
C. Side Trim	15" (381 mm)	10" (254 mm)

Fig. 14 Maintain clearances to combustible components of the mantelpiece.

Unprotected top trim (B) protruding 2" (51 mm) or less from the face of the fireplace must be a minimum of 24" (610 mm) from the stove's top surface. With a ventilated trim shield, this clearance may be reduced safely to 14" (356 mm).

Unprotected side trim (C) that protrudes 2" (51 mm) or less from the face of a fireplace must have a minimum clearance of 15" (380 mm), measured from the stove's top side edge. With a ventilated trim shield, the clearance may be reduced safely to 10" (254 mm). If the trim extends more than 2" (51 mm), wall clearance requirements apply.

The charts and sample installations that follow list the clearances required for the various installation configurations of the Intrepid Multi-fuel.

Alcove Installations

Because of their restricted air flow and heat retention characteristics, specific construction requirements and special clearances apply to installations into alcoves. No stove or chimney connector heat shields are used in alcove installations.

Construction Requirements

The following illustrations show noncombustible ceiling framing and maximum and minimum permitted dimensions for alcove construction.

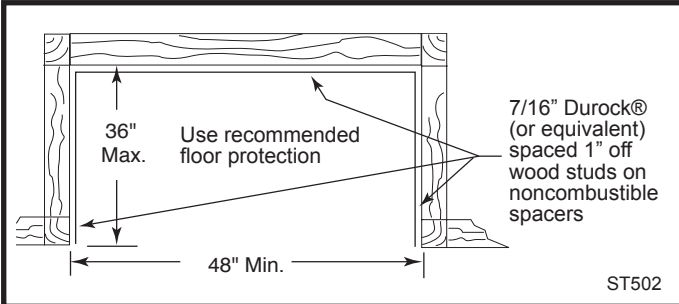

Fig. 15 Alcove floor plan. Sheetrock on front face butts to Durock® (or equivalent) alcove lining.

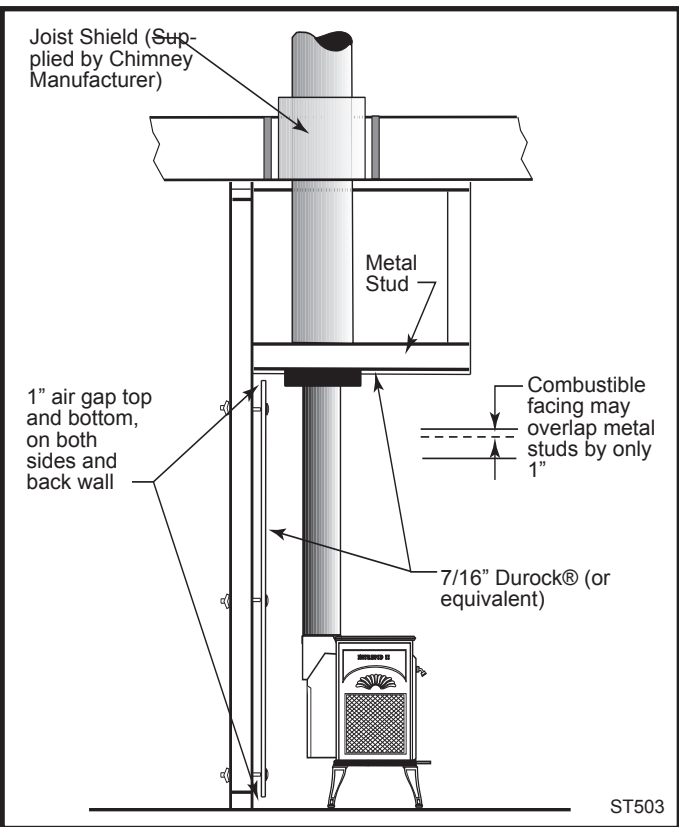

Fig. 16 Alcove side section.

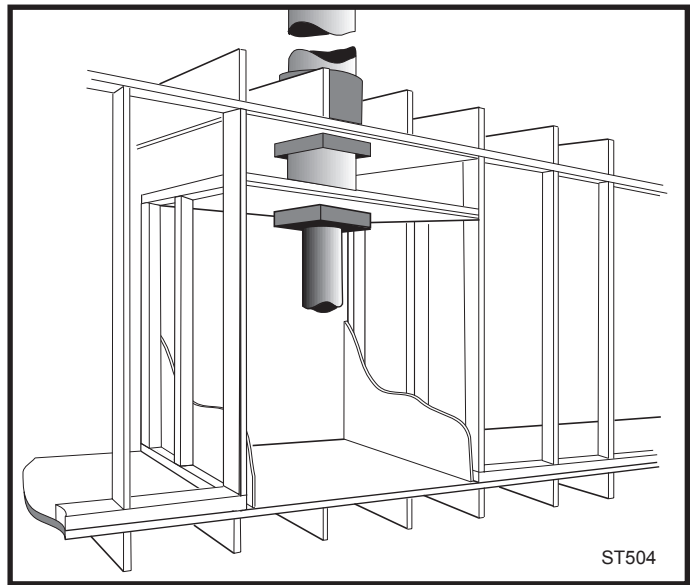

Fig. 17 Cutaway perspective of alcove installation.

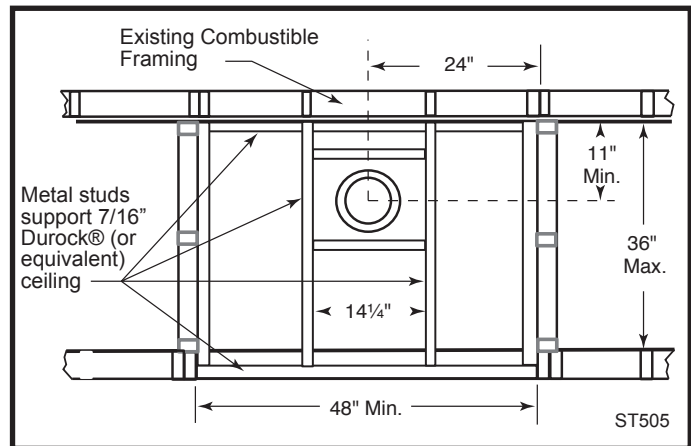

Fig. 18 Reflected ceiling plan.

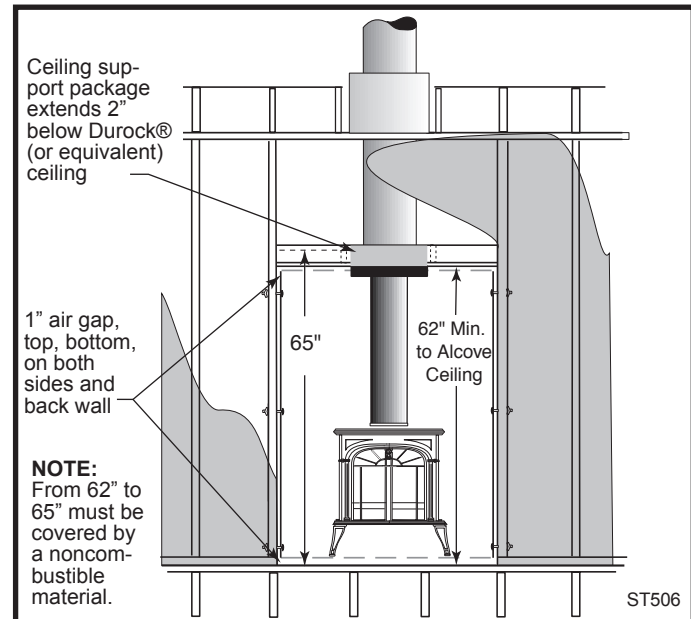

Fig. 19 Front view: 65" minimum clearance from hearth to combustibles on front face. Combustible facing may overlap metal studs by only 1". It should not extend below the height of the noncombustible ceiling.

Intrepid Multi-Fuel Clearance Chart

See Pages 14 and 16 for illustrations of these clearances.

	Unprotected Surfaces			Protected Surfaces		
	Stove Clearance					
	Stove Installed Parallel to Wall		Stove in Corner	Stove Installed Parallel to Wall		Stove in Corner
	Side	Rear	Corners	Side	Rear	Corners
No stove heat shields	(A) 24" (610 mm)	(B) 30" (762 mm)	(C) 20" (508 mm)	(D) 12" (305 mm)	(E) 16" (410 mm)	(F) 10" (254 mm)
Top exit, rear stove h.s., single-wall chimney connector with connector heat shields ^{1,2}	(G) 24" (610 mm)	(H) 16" (410 mm)	(I) 12" (305 mm)	(J) 12" (305 mm)	(K) 9" (229 mm)	(L) 10" (254 mm)
Rear exit, rear stove heat shield only ³	(M) 24" (610 mm)	(N) 14" (356 mm)	(NA)	(P) 12" (305 mm)	(Q) 9" (229 mm)	(NA)
Top exit, rear stove h.s., double-wall chimney connector ⁵	(G) 24" (610 mm)	(H) 16" (410 mm)	(I) 12" (305 mm)		*	
Chimney Connector Clearance						
Single-wall chimney connector, no connector heat shields	26 " (661 mm)			12" (305 mm)		
Single-wall chimney connector, with connector heat shields	10" (254 mm)			5" (127 mm) ⁴		
Double-wall connector ⁵	12" (305 mm)			*		
Front Clearance to Combustibles						
All Installations 48" (1219 mm)						

* Clearances with double-wall connectors and protected surfaces have not been tested for the Intrepid.

1. Shielding for a top exit stove must include the stove rear heat shield insert to protect the area behind the flue collar.
2. Chimney connector heat shields, in an installation that goes through a combustible ceiling, must extend to 1" (25 mm) below the ceiling heat shield, which is 22" (559 mm) in diameter. The ceiling heat shield should be 24 gauge or heavier sheet metal, centered on the chimney connector, and mounted on non-combustible spacers.
3. Rear exit—horizontal from flue collar directly back through wall.
4. The ceiling heat shield required when chimney connector shields are used should meet the wall protector. This will require trimming the ceiling shield along the line of intersection with the wall protector.
5. In top exit installations, this clearance requires the use of the rear heat shield with the shield insert installed.

Intrepid Multi-fuel Clearance Diagrams

See the chart on Page 13 for dimensions indicated by letter in the diagrams below.

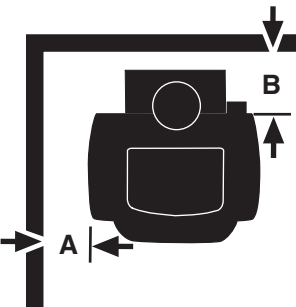
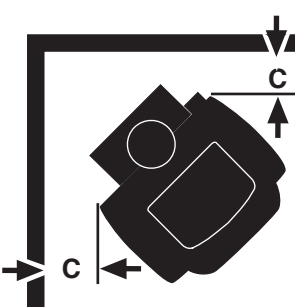
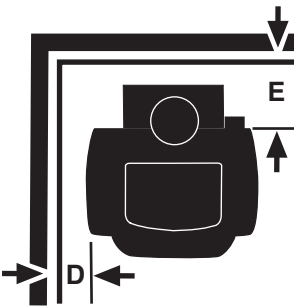
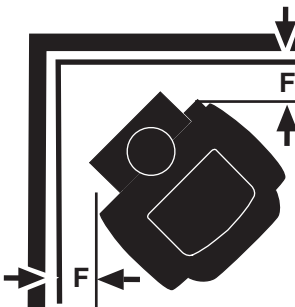
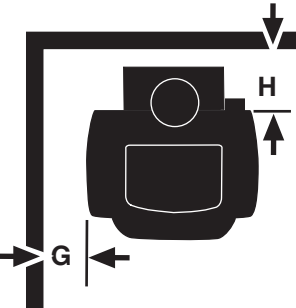
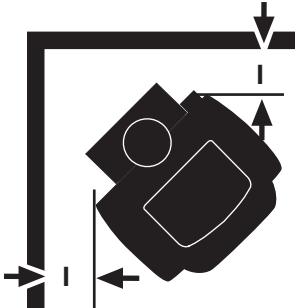
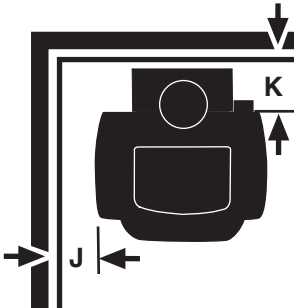
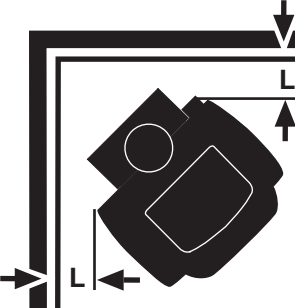
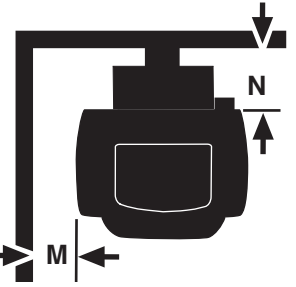
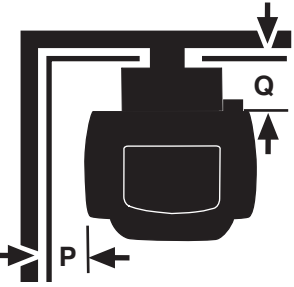
Unprotected Surfaces		Protected Surfaces	
Stove Installed Parallel to Wall	Stove in Corner	Stove Installed Parallel to Wall	Stove in Corner
Top Exit Installations, no heat shields			
			
Top Exit Installations, rear heat shield, and chimney connector heat shields or double-wall connector			
			
Rear Exit Installations, rear heat shields.			
	<p style="text-align: center;">N/A</p>		<p style="text-align: center;">N/A</p>

ST507

Wall Shield Requirements for Common Installations

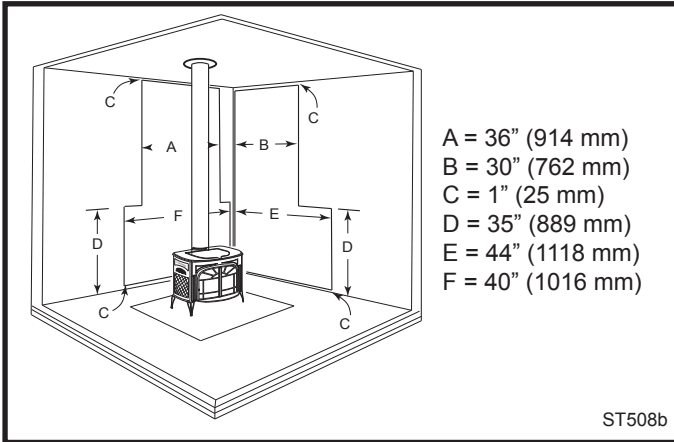

Fig. 20 Parallel installation, vertical chimney connector, two wall shields. Reduced clearances for both rear and side walls. Wall shields may meet at corner if desired. Shielding for connector is centered behind connector.

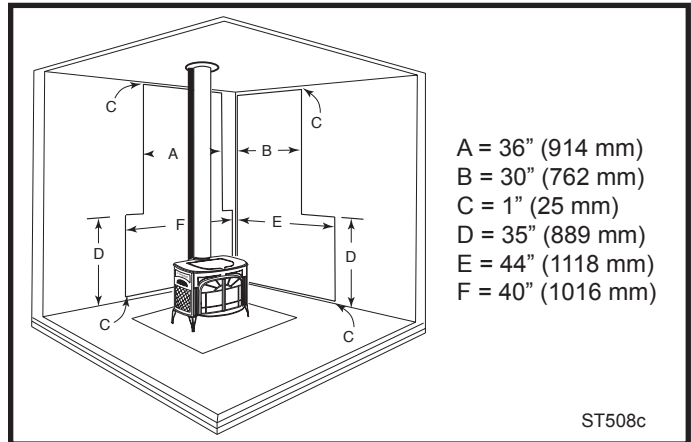

Fig. 23 Parallel installation, vertical chimney connector, with stove, connector and wall shields. Maximum reduction for rear and side walls. Wall shields may meet at corner. A heat shield 24" (610 mm) in diameter suspended 1" (25 mm) below the ceiling must surround the chimney.

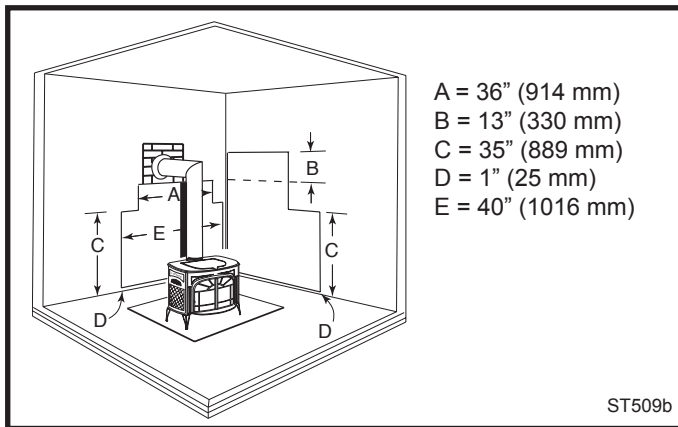

Fig. 21 Parallel installations with rear wall pass-through, two wall shields. Reduced clearances for both rear and side walls. Wall shields may meet at corner if desired. Shielding for connector is centered behind connector. Wall pass-through must comply with codes.

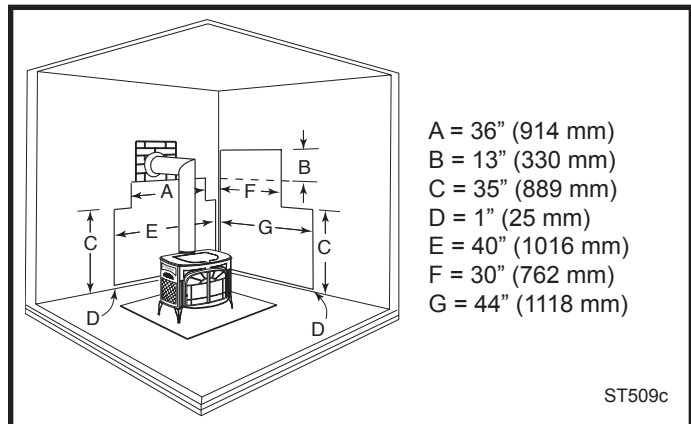

Fig. 24 Parallel installation with rear wall pass-through, with stove, connector and wall shields. Wall shields may meet at corner. Connector heat shield extends 28" (711 mm) above flue collar, or below elbow, whichever is less. Wall pass-through must comply with codes.

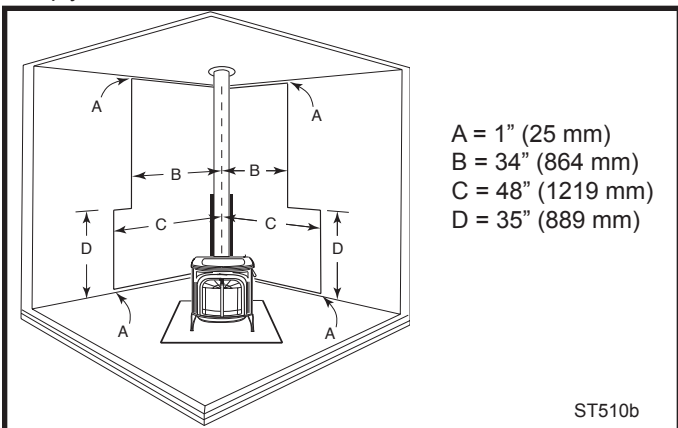

Fig. 22 Corner installation, vertical chimney connector, with rear, stove, connector and wall shields. Wall shields **MUST** meet at corner. Connector heat shield extends 28" (711 mm) above flue collar. A 24" (610 mm) diameter ceiling heat shield must surround the chimney and be suspended 1" (25 mm) from ceiling.

2000970

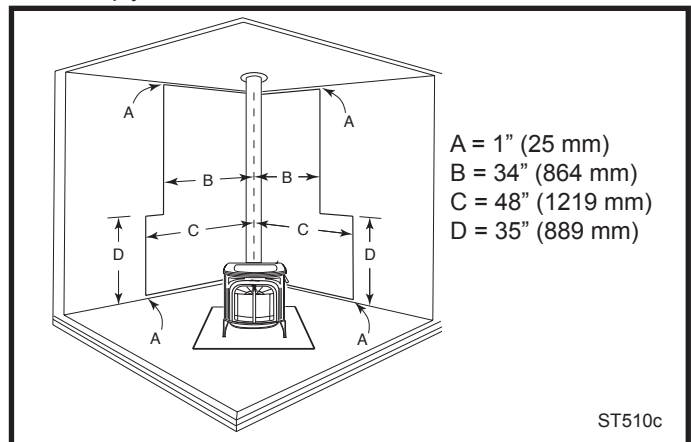

Fig. 25 Corner installation, vertical chimney connector, two wall shields. Reduced side clearances. Wall shields **MUST** meet at corner.

Distance from the Center of the Flue Collar to the Wall in Top-Exit Installations

The information on this page is helpful in planning stove placement for top-exiting installations, particularly those installations with chimneys that pass through the ceiling. However, this is not a clearance chart. Final stove clearances must adhere to the guidelines stated in the clearance charts on Page 13.

Intrepid Multi-fuel: WITHOUT Stove and Chimney Connector Heat Shields					
Unprotected Surfaces			Protected Surfaces		
Parallel Installations		Corner Installations**	Parallel Installations		Corner Installations**
Side (A)	Rear (B)	Corner (C)	Side (D)	Rear (E)	Corner (F)
34 ³ / ₄ " (883 mm)	29" (737 mm)	26 ³ / ₄ " (680 mm)	22 ³ / ₄ " (578 mm)	11" (279 mm)	16 ³ / ₄ " (426 mm)

ST511

* This distance, from the center of the flue collar to the front edge of the hearth, is the same for all installations on this page: 35" in the United States and 37" (940mm) in Canada.

Intrepid Multi-fuel: WITH Stove and Chimney Connector Heat Shields					
Unprotected Surfaces			Protected Surfaces		
Parallel Installations		Corner Installations**	Parallel Installations		Corner Installations**
Side (A)	Rear (B)	Corner (C)	Side (D)	Rear (E)	Corner (F)
34 ³ / ₄ " (883 mm)	15" (381 mm)	18 ³ / ₄ " (476 mm)	22 ³ / ₄ " (578 mm)	8" (203 mm)	16 ³ / ₄ " (426 mm)

ST511a

** To locate center of flue collar for corner installation, add 7" (178 mm) to the clearance distance from stove corner to wall. Mark off the resulting distance from the corner along both walls. Next, measure the same distance from these two points out from the walls. These last two measurements will meet at a point representing the center of the flue collar. Refer to the diagrams above.

Assembly

Clean the Griddle Before Use

At the factory we coat the griddle with vegetable oil to prevent rusting while the stove is in transit and storage. Remove the oil with a dry rag or paper towel before you use the stove.

Set Up the Stove

Remove the griddle, front grate bar, the bottom grate, the side bricks, and the ash pan from inside the stove. Place a protective pad on the floor, arrange some sections of 4 x 4 lumber on the pad for support, and carefully tip the stove back onto them.

Remove and discard the four large slot-head screws from the stove bottom (Fig. 26) and install the stove legs, using the hex head bolts from the parts bag. Use 3/8" washers with three of the legs; the door/damper handle holder installs in place of a washer on the right front leg. Position the holder so the hole to accept the handle nub faces out from the right side of the stove. Tighten the bolts firmly.

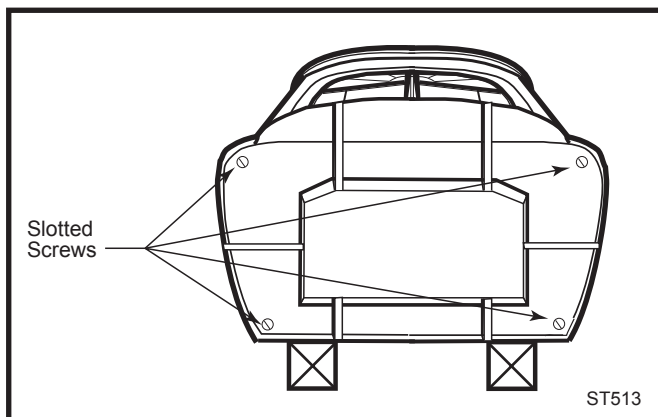

Fig. 26 Remove the slotted screws from the stove bottom.

Install the Bottom Heat Shield

To install the bottom heat shield, loosen the leg bolts, and slip the bottom heat shield C-clips onto the bolts. Orient the heat shield so that the longest (10 3/4") edge is at the front of the stove. (Fig. 27) Attach the heat shield to the C-clips with the wing nuts and then tighten the leg bolts.

Storing the Handle

Use the removable handle to open or close the front doors, or to change the position of the damper. After use, remove the handle so it will not get hot, and store it in the handle holder installed behind the right front leg. (Fig. 28)

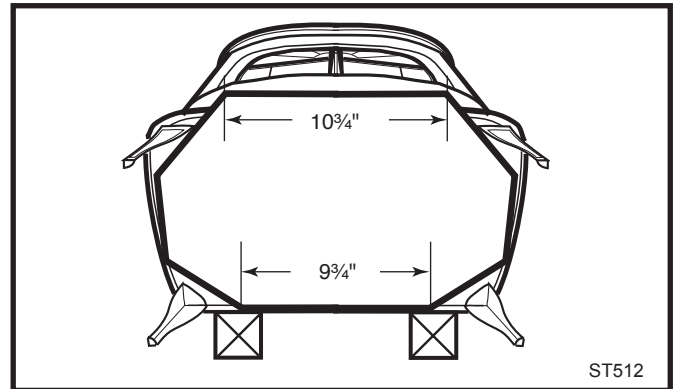

Fig. 27 Attach bottom heat shield.

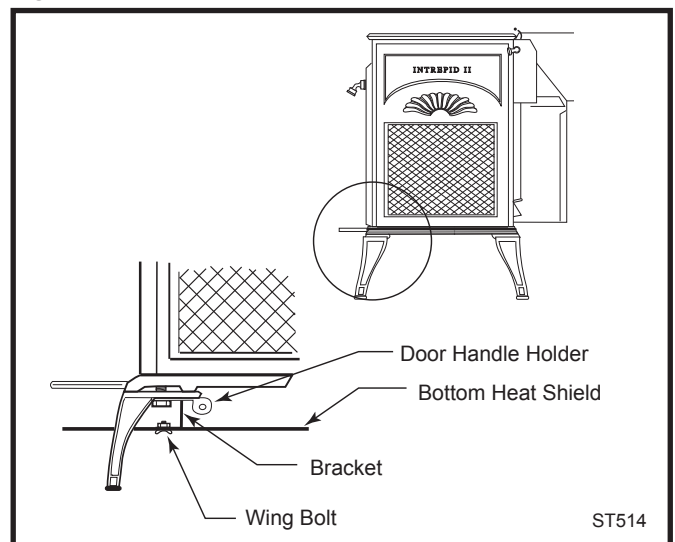

Fig. 28 Handle holder and heat shield positions.

Reversing the Flue Collar

You can reverse the flue collar by removing the two screws that attach the collar to the back of the stove, as in Figure 29. Be sure the gasket around the flue collar opening is in position when you screw the collar back on to the stove.

Attach the Griddle Handle

Install the handle on the griddle. Place the griddle upside down at the edge of a flat surface and assemble the handle as shown. (Fig. 30)

With the handle pointing 45° from its final position, tighten the nut as far as possible with pliers. Move the handle to its final position while still holding the nut with the pliers.

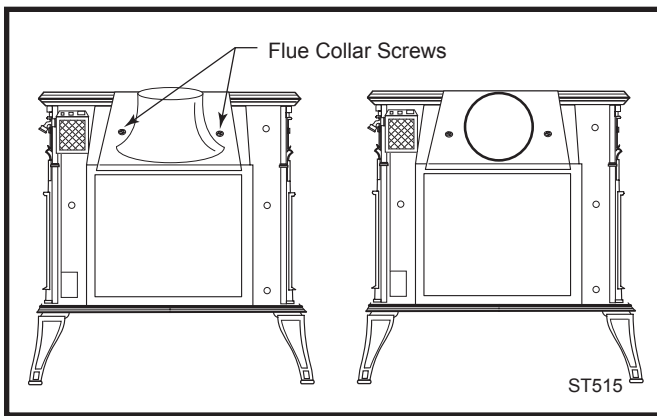

Fig. 29 Reversing the flue collar.

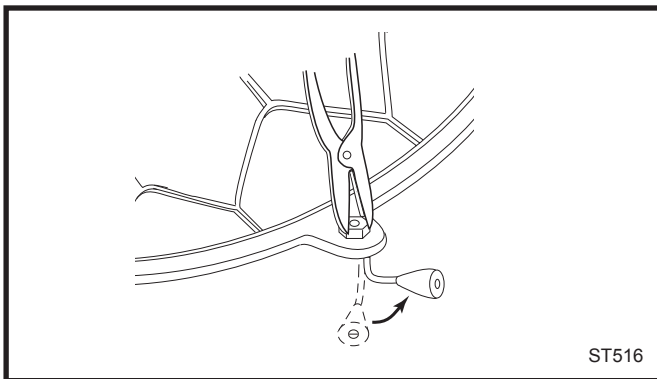

Fig. 30 Attaching the griddle handle.

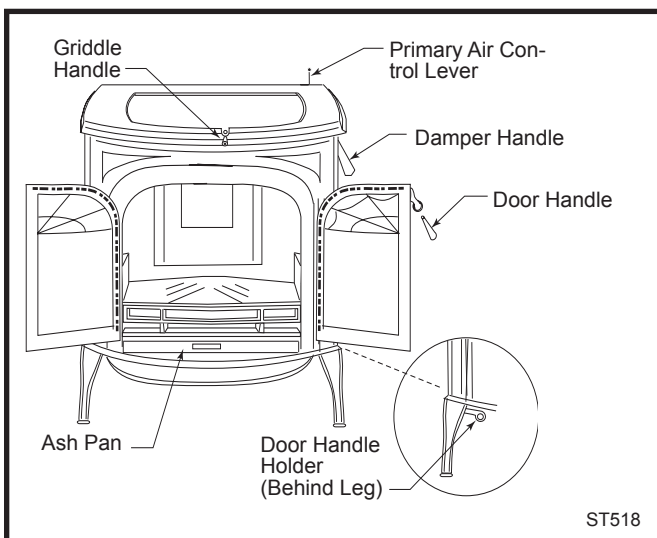

Fig. 31 The Intrepid Multi-fuel controls.

Operation

Intrepid Multi-fuel's Controls

Two controls are used to regulate the performance of the Intrepid Multi-Fuel. A **primary air control** regulates the oxygen supply for the fire, and a **damper** directs combustion gases through a heat exchanger passage in the rear. (Fig. 31)

Primary Air Control

The **primary air control lever**, located at the right rear corner of the stove, controls the amount of incoming air for starting, maintaining, and reviving a fire. More air entering the stove makes the fire burn hotter and faster, while less air prolongs the burn at a lower heat level. (Fig. 32)

For the greatest air supply and maximum heat output (but the shortest burn time), move the lever to the left. For a fire that will last longer with less heat, move the lever to the right. You can set the lever anywhere in between the left and right extremes, shown in Figure 32. With some experimentation, you will soon discover the optimum setting that will provide the desired comfort/performance level from the type of fuel you are using.

The Intrepid Multi-fuel also features an automatic thermostat that works in conjunction with the primary air control shutter to ensure an even heat output at any manual setting you select. The thermostat responds to the temperature of the cast iron, closing and opening the air inlet as the fire intensity rises and falls.

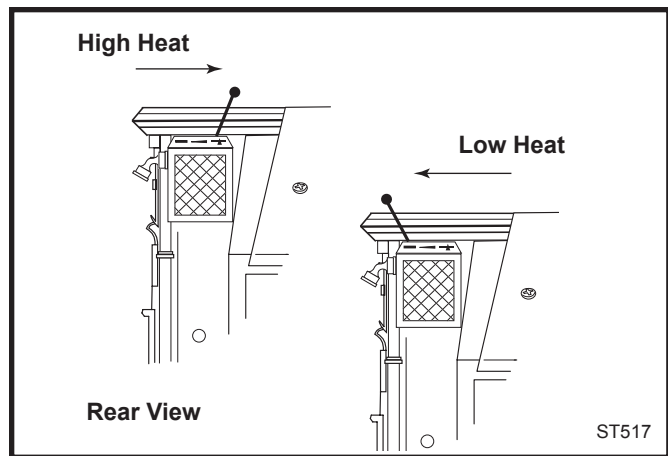

Fig. 32 The thermostat handle may be positioned anywhere between the two extremes for different heat levels.

The Damper

The **damper handle**, located on the right side of the stove, is used to open and close the damper plate. Use the removable door/damper handle to operate the handle shaft. (Fig. 33)

The damper is open when the handle points to the floor. (Fig. 33) In this position, smoke passes directly into the chimney. the damper must be open when starting or reviving a fire, and whenever the griddle or doors are opened.

When the handle points to the front, the damper is closed. Smoke from the fire is directed through the rear heat exchanger before passing up the chimney.

The damper has no intermediate positions.

When closing the damper, push firmly until you feel the mechanism engage into the locked position.

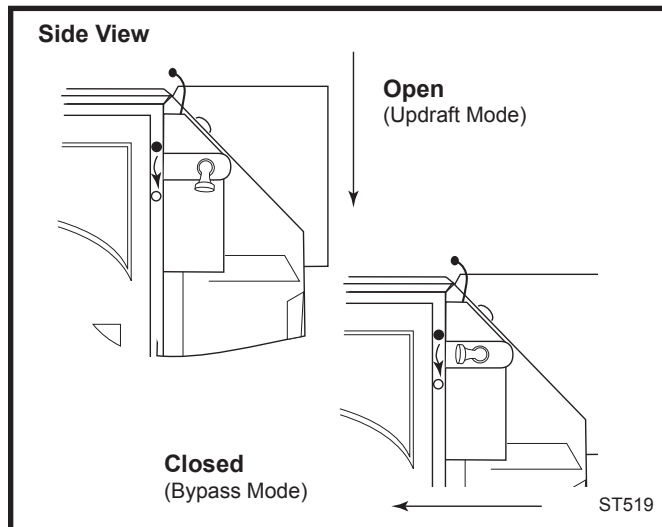

Fig. 33 The damper is either open or closed. There are no intermediate positions.

Glass Door Panels

The glass panels in the doors have a heat-reflective coating on the outside surface. Heat reflected back to the inside of the glass helps keep the inner surface at a higher temperature than the outside. In combination with preheated primary combustion air 'washing' over the inside of the glass, this helps provide clear fire-viewing at most operating levels.

Front Grate

Your stove has a front grate to keep fuel away from the glass panels. These bars are important to maintain clear fire viewing and to keep the fuel off the glass. Under normal operating circumstances should not be removed.

Two Ways to Add Fuel

The Intrepid Multi-fuel's griddle lifts for convenient top-loading of logs, and is the easiest way of regularly adding fuel. The front doors open as well to allow you to tend the fire with a variety of fuels. Use the included slicer/poker to help ash accumulation fall through the grate and to enliven the fire after adding fuel. (Fig. 34)

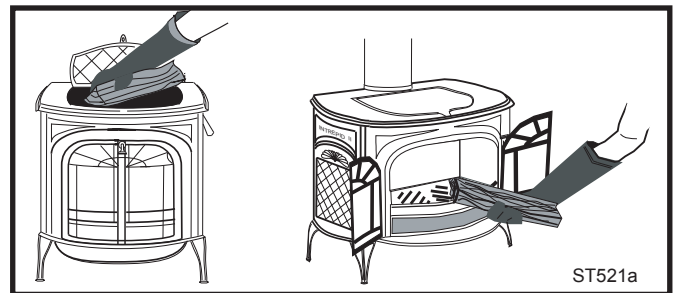

Fig. 34 Top loading is the best way to add fuel during regular use. Front loading is useful for kindling a fire.

You can open (or even remove) the front doors and place the optional Intrepid spark screen in the front opening for open-fire viewing.

WARNING: For safety and greatest efficiency, operate your stove only with all doors/griddles fully closed.

Your stove may be used as a fireplace with the front doors open or removed only when the spark screen is placed correctly in the opening to protect against the possibility of sparks and embers leaving your stove.

Use only the Intrepid Multi-fuel spark screen, part #0136, with your Intrepid Multi-fuel.

The Intrepid Multi-fuel spark screen is available from your Vermont Castings' Authorized Dealer.

To open the front doors, insert the handle into the door latch stub and turn it to the left and up. To close them, always close the left door first. Turn the handle in the right door to the left and up (to the open position) and close the door. Push on the door as you turn the handle to the right and down. The doors will draw in slightly, and the handle should offer some resistance as you turn it to the closed position. (Fig. 35)

Avoid striking the glass or slamming the doors to reduce the risk of breaking the glass or damaging porcelain enamel surfaces.

When you're not using the door handle, store it in the holder behind the right front leg of the stove.

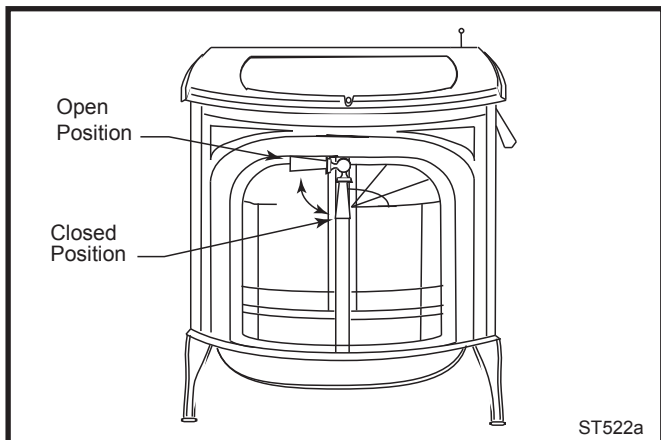

Fig. 35 To open the front doors, turn handle clockwise.

Use the Air Control Settings that Work Best for You

No single air control setting will fit every situation. Settings will differ depending on the quality of the fuel, the amount of heat desired, and how long you wish the fire to burn.

The control setting also depends on your particular installation's "draft," or the force that moves air from the stove up through the chimney. Draft is affected by such things as the length, type, and location of the chimney, local geography, nearby obstructions, and other factors.

When first using the stove, keep track of the air control settings. You will quickly find that a specific setting will give you a fixed amount of heat. It may take some time to determine the amount of heat and the length of burn you should expect from various settings and fuels.

Most installations do not require a large amount of combustion air, especially if adequate draft is available.

Do not for any reason attempt to increase the firing of your heater by altering the air control adjustment range outlined in these directions.

Use the following air control settings as a starting point to help determine the best settings for your installation. Each is described as a fraction of the total distance the lever may be moved from right to left.

Intrepid Multi-Fuel Control Settings

Burn Rate	Primary Air Control
Low	From far right to 1/3 the distance to left
Medium	From 1/3 to 2/3 the distance to left
High	From 2/3 the distance to left to far left

Before you start using the stove, please read the Draft Management section starting on page 22 to see how the features of your installation will affect the stove's performance. You and the stove are parts of a system, and other parts of the system have a strong effect on operation; you may need to vary your firing technique to get the performance you want.

How To Build a Wood Fire and Keep It Going

Conditioning Your Stove

Cast iron is extremely strong, but it can be broken with a sharp blow from a hammer or from the thermal shock of rapid and extreme temperature change.

The cast plates expand and contract with changes in temperature. When you first begin using your Intrepid Multi-fuel, minimize thermal stress by allowing the plates to adjust gradually during three or four initial break-in fires following Steps 1-3 below.

Burn only high quality wood or smokeless solid fuels in the Intrepid Multi-Fuel, and burn it directly on the grate. Do not elevate the fuel.

The damper must be open when starting a fire or when refueling.

1. Open the stove damper, and open the primary air control fully.
2. Place several sheets of crumpled newspaper in the stove. Do NOT use glossy advertisements or colored paper, as they can poison the catalyst. Place on the paper six or eight pieces of dry kindling split to a finger-width size, and on the kindling lay two or three larger sticks of split dry wood approximately 1-2" (25-50 mm) in diameter. (Fig. 36)

Do not use chemicals or fluids to start the fire.

Do not burn garbage or flammable fluids such as gasoline, naphtha, or engine oil. Also, never use gasoline-type lantern fuel, kerosene, charcoal lighter fluid, or similar liquids to start or "freshen up" a fire. Keep all such liquids well away from the Intrepid Multi-Fuel while it is in use.

3. Light the newspaper and close the door. Gradually build up the fire by adding a few 3-5" (80-120 mm) diameter splits. **If this is one of the first few "break-in" fires, let the fire burn brightly, and then let it die out.**

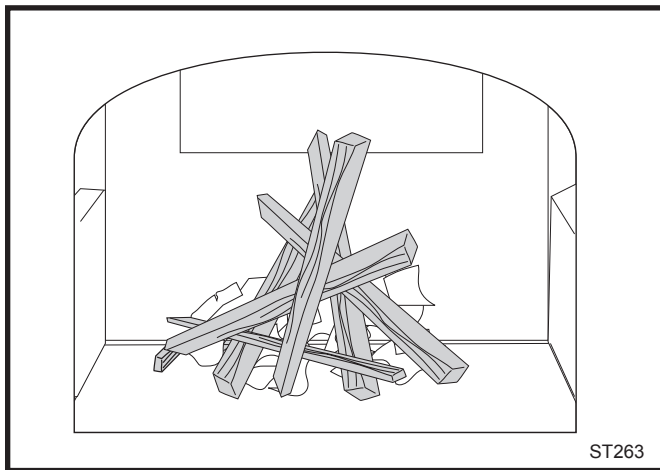

ST263

Fig. 36 Start the fire with newspaper and dry kindling.

During the break-in fires, keep the stove temperature under 500°F (260°C) as measured on an optional stove-top thermometer. Adjust the air control lever as necessary to control the fire.

Some odor from the stove's hot metal, the paint and the cement is normal for the first few fires.

NOTE: Some chimneys need to be "primed," or warmed up, before they will draw sufficiently to start a fire. To correct this situation, roll up a couple pieces of newspaper, place them on top of the kindling and toward the back of the stove, light them, and close the doors. This should heat the chimney enough to initiate a draft.

Once the draft is established, open the front door and light the rest of the fuel from the bottom. Do not light the main bed of fuel until the chimney begins drawing, and repeat the procedure as often as necessary if the initial attempt is unsuccessful.

4. **If your stove has been broken-in previously** using Steps 1-3, continue to build the fire gradually. Add larger wood with a diameter of 3-4" (76-102 mm), as in Figure 37.

Continue adding split logs of this size to the briskly-burning fire until there is a glowing ember bed at least 3" (75 mm) deep. A good ember bed is necessary for proper functioning of the catalytic system and may take an hour or more to establish.

5. Close the damper when the griddle temperature reaches 450° F. (230°C).
6. Adjust the air control for your desired heat output.

Refuel While the Embers Are Still Hot

Reload the Intrepid Multi-Fuel while it is still hot and there are plenty of glowing embers to rekindle the fire. Include some smaller pieces of wood in the new load of fuel to help the stove rebuild its operating temperature quickly.

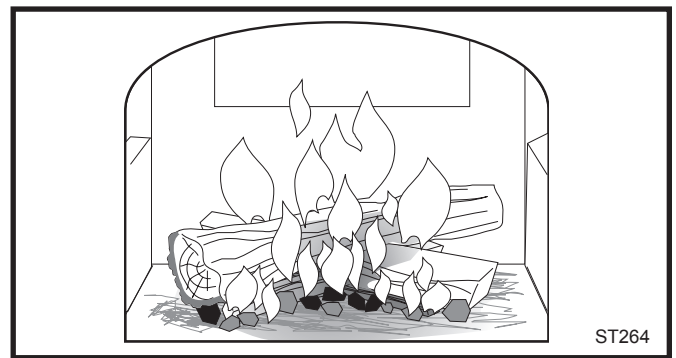

ST264

Fig. 37 Add larger pieces of wood as the fire begins to burn well.

Wear stove gloves, and follow this procedure when you reload your stove:

1. Open the thermostat lever.
2. Open the damper.
3. Check the ash level in the ash pan; empty, if necessary, and replace the pan.
4. Use the slicer/poker to freshen the coals. Position the coals in the middle of the firebox.
5. Add fuel.

NOTE: If the remaining charcoal bed is relatively thick and if your fuel is well seasoned, it is possible to add fresh fuel (smaller pieces first), close the door and damper, and reset the primary air thermostat for the desired heat output.

Do not break the charcoal into very small pieces or pound or compress the charcoal bed. It is important that air can circulate under the wood for the fire to be quickly revived.

WARNING: Operate your Intrepid Multi-fuel only with the doors either fully open or fully closed.

CAUTION: The stove will be hot while in operation. Keep children, clothing and furniture away. Contact may cause skin burns.

DO NOT OVERFIRE THIS HEATER. Overfiring may cause a house fire, or can result in permanent damage to the stove. If any part of the stove glows, you are overfiring.

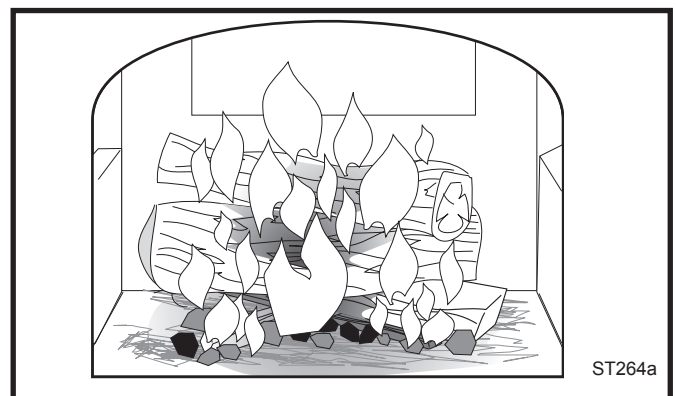

ST264a

Fig. 38 Add full size logs when the ember bed is 3" (75mm) deep.

Ash Disposal

Remove ash before it reaches the top of the ash pan. Check the level at least once a day, and before each refueling. If the ash is close to the top edge of the pan, empty it according to this procedure:

1. Open the damper.
2. Open the front doors fully.
3. Using stove gloves, pull the ash pan out of the stove by its handle.
4. Remove the ash pan and properly dispose of the ashes. Be sure to keep the pan level during disposal.
5. Return the ash pan to the stove.

Empty the ash pan regularly, typically every one to three days. The frequency will vary depending on how you operate your stove; if you burn more wood at higher heat output settings, ash will accumulate rapidly.

Remove ash frequently and place it outdoors in a metal container with a tight-fitting lid. Put the closed container of ash on a noncombustible floor or on the ground, well away from all combustible materials, pending final disposal. If the ash is disposed of by burial in soil or otherwise locally dispersed, keep it in the closed container until all cinders have thoroughly cooled. You can use wood ash as a garden fertilizer.

CAUTION: Never use your household or shop vacuum cleaner to remove ash from the stove; always remove and dispose of the ash properly.

Draft Management

A stove is part of a system, which includes the chimney, the operator, the fuel, and the home. The other parts of the system will affect how well the stove works. When there is a good match between all the parts, the system works well.

Wood stove operation depends on natural (unforced) draft. Natural draft occurs when the smoke is hotter (and therefore lighter) than the outdoor air at the top of the chimney. The bigger the temperature difference, the stronger the draft. As the smoke rises from the chimney it provides suction or 'draw' that pulls air into the stove for combustion. A slow, lazy fire with the stove's air inlet fully open indicates a weak draft. A brisk fire, supported only by air entering the stove through the normal inlet, indicates a good draft. The stove's air inlet is passive; it regulates how much air can enter the stove, but it doesn't move air into it.

Depending on the features of your installation - steel or masonry chimney, inside or outside the house, matched to the stove's outlet or oversized - your system may warm up quickly, or it may take a while to warm up and operate well. With an 'airtight' stove, one which restricts the amount of air getting into the firebox, the chimney

must keep the smoke warm all the way to the outdoors. Some chimneys do this better than others. Here's a list of features and their effects.

Masonry Chimney

Masonry is a traditional material for chimneys, but it can perform poorly when it serves an 'airtight' stove. Masonry is a very effective 'heat sink' - it absorbs a lot of heat. It can cool the smoke enough to diminish draft. The bigger the chimney, the longer it takes to warm up. It's often very difficult to warm up an outdoor masonry chimney, especially an oversized one, and keep it warm enough to maintain an adequate draft.

Steel Chimney

Most factory-made steel chimneys have a layer of insulation around the inner flue. This insulation keeps the smoke warm. The insulation is less dense than masonry, so the inner steel liner warms up more quickly than a masonry chimney. Steel doesn't have the good looks of masonry, but it performs much better.

Indoor/Outdoor location

Because the chimney must keep the smoke warm, it's best to locate it inside the house. This uses the house as insulation for the flue and allows a little heat release into the home. An indoor chimney won't lose its heat to the outdoors, so it takes less heat from the stove to get it warm and keep it warm.

Flue sizing

The inside size of a chimney for an 'airtight' stove should match the size of the stove's flue outlet. When a chimney serves an airtight stove, more is not better; in fact, it can be a disadvantage. Hot gases cool off through expansion; if we vent a stove with a six-inch flue collar (28 square inch area) into a 10 x 10" flue, the gases expand to over three times their original size. This cools the gases, which weakens draft strength. If an oversized flue is also outside the house, the heat it absorbs gets transferred to the outdoor air and the flue usually stays cool.

It's common for a masonry flue, especially one built for a fireplace, to be oversized for an airtight stove. It can take quite a while to warm up such a flue, and the results can be disappointing. The best solution to an oversized flue is an insulated steel chimney liner, the same diameter as the stove or insert's flue outlet; the liner keeps the smoke at its original volume, and the result is a stronger draft. An uninsulated liner is a second choice - the liner keeps the smoke restricted to its original size, but the smoke still must warm up the air around the liner. This makes the warm-up process take longer.

Pipe & Chimney Layout

Every turn the smoke must take in its travel from the stove to the chimney top will slow it down. The ideal pipe and chimney layout is straight up from the stove, to a completely straight chimney. If you're starting from scratch, use this layout if possible. If the stove-pipe must elbow to enter a chimney, locate the thimble about midway between the stove top and the ceiling. This achieves several goals: it lets the smoke speed up before it must turn, it leaves some pipe in the room for heat transfer, and it gives you long-term flexibility for installing a taller stove without relocating the thimble.

There should be no more than eight feet of single-wall stove pipe between the stove and a chimney; longer runs can cool the smoke enough to cause draft and creosote problems. Use double-wall stove pipe for long runs.

Single Venting

Each 'airtight' stove requires its own flue. If an airtight stove is vented to a flue that also serves an open fireplace, or a leakier stove, it's easier for the chimney draft to pull air in through those channels than it is to pull air through the airtight, and performance suffers. Imagine a vacuum cleaner with a hole in the hose to see the effect here. In some cases the other appliance can even cause a negative draft through the airtight, and result in a dangerous draft reversal.

Creosote

Creosote is a by-product of slow woodburning. It's an organic tar that can condense in the flue if it's dense in the smoke, and slow-moving, and cools off to less than 290° F. Condensed creosote is volatile, and can generate chimney fires if it gets hot enough. All the features that affect chimney draft also affect creosote condensation - so use whatever combination of installation features and operational steps will encourage good draft and minimize creosote production.

Because letting the smoke cool off and slow down is one of the keys to creosote production, it makes sense to line a chimney to match the stove's outlet size, for safety reasons as well as performance. Canadian law requires a matching liner to serve any stove or insert vented through a fireplace chimney; in the US, the National Fire Protection Association recommends one if the flue is more than three times bigger (in square area) than the outlet on the stove or insert. Some localities enforce the NFPA guidelines as part of their building codes.

Fuel

Even the best stove installation will not perform well with poor fuel. The best fuel is hardwood that has air-dried 12-18 months. Softwood burns, but not as long as hardwood. Fairly 'green' wood has a good amount of moisture in it; it will burn, but some of the heat potential is used to drive the remaining moisture off the wood. This reduces the amount that reaches your home and can contribute to a creosote problem. There are moisture meters available for firewood; you can also judge your wood by its appearance and weight. If you get it green, lift a piece and get a sense of its weight; it can lose a third or more of its weight as it dries. Also look at the ends of a log; as it dries it shrinks and often cracks. The more weathered and cracked a piece is, the drier it is.

Dry wood burns readily with a good chimney draft. But with modern stoves, especially catalytic ones, the wood can be too dry. While extra-dry wood has little creosote in it, the remainder can 'gas out' from the wood quickly and densely enough to overload the catalytic burner. If you hear a rumbling or roaring noise, like a propane torch, from the stove, that is a sign that the catalyst is seriously overfiring. The catalyst is a platinum film on a ceramic base; the metal can get to higher temperatures than the ceramic can take, and overfiring the catalyst can break it. Dry wood can also burn out faster than you want. If your dry wood burns out too quickly or overloads the catalyst you can mix in greener wood to slow the fire down.

Backpuffing

Back-puffing results when the fire produces volatile gases faster than the chimney draft pulls them out of the firebox. The gases back up in the firebox till they're dense enough and hot enough to ignite. If your stove back-puffs, you should open up the damper to let the smoke rise to the flue more quickly, let more air into the firebox, and avoid big loads of firewood. Run your stove with enough primary air so that you always see lively, dancing flames in the firebox; a lazy, smoky fire is inefficient and can contribute to creosote buildup in the chimney.

Draft Testing

An easy way to test your chimney draft is to close the stove's damper, wait a few minutes to let the airflow stabilize, then see whether you can vary the strength of the fire by swinging the air control open and closed. Results are not always instant; you may need to wait a few minutes for a change in the air control setting to have an effect on the fire. If there's no change, then the draft isn't strong enough yet to let you close the damper, and you'll need to open it for a while longer and manage the fire with the air inlet until the draft strengthens. If you keep track of your burning habits and relate them to their effects on the stove's operation, you'll be rewarded with good performance and a safe system.

Negative Pressure

Good draft also depends on a supply of air to the stove; a chimney can't pull in more air than is available to it. Sluggish draft results when a house is tight enough to prevent the ready flow of air to the stove, or by competition between the stove and other equipment that sends indoor air outside - especially power-driven equipment like range hoods, clothes dryers, etc. If the chimney draws well with all other equipment turned off (or

sealed, in the case of fireplaces and/or other stoves), then you simply need to be careful with timing the use of the other equipment. If you need to crack a nearby window or door to enable the chimney to draw well, that's a sign that you should install an outside-air intake to bring combustion air directly to the stove. Vermont Castings dealers carry adapters to attach to the stove to connect an air duct for outdoor combustion air.

Conclusion

Woodburning is an art rather than a science. Once the stove and chimney system are in place, the stove user can only vary technique, mostly your timing, to achieve good results. If you keep track of your burning habits and relate them to their effects on the stove's operation, you'll be rewarded with good performance and a safe system.

Maintenance

Let the fire in the stove go out and allow the stove to cool completely before beginning any maintenance procedure.

Care of the Cast Iron Surface

An occasional dusting with a dry rag will keep the painted cast iron of your Intrepid looking new. The stove's paint can be touched up as needed. First, clean the areas to be painted with a wire brush. Remove the griddle and set it aside. Then, touch up the stove with Vermont Castings high temperature stove paint. Apply the paint sparingly, and keep in mind that two light coats of paint are better than a single heavy one.

Care of Porcelain Enamel Finish

Use a dry or slightly damp rag or a soft brush to remove spills or stains. For difficult jobs that require a cleaning agent, use only a kitchen appliance cleaner or polish recommended for use on enamel surfaces.

Cleaning the Glass

Most of the carbon deposits on the glass will burn off during hot fires. However, the ash residue that accumulates on the glass surface should be removed regularly to prevent etching. Follow this procedure to clean the glass:

- Be sure the glass is completely cool.
- Clean the glass with water or a cleaner made especially for this purpose. Do not use abrasive cleaners.
- Rinse the glass thoroughly.
- Dry the glass completely.

Glass Replacement

The panes of glass in the doors of the Intrepid rest on a cushion of gasket, and are held in place by four clips. The glass is coated on one side. The coated side is slightly colored and is further identified with white labels marked "CV+". Remove the doors from the stove and place them on a sturdy, level work surface. To install the glass, follow this procedure:

1. Remove the door. Swing the door back and forth while lifting it, to remove its hinges from the stove front. Set the door down on a flat, padded surface. Remove the clips and the broken glass; set them aside.
2. Inspect the Gasket. If the window gasket is in good condition, you can leave it in place. If you replace it, use only a Vermont Castings gasket, part no. 1203556. Be sure the channel around the window opening is clean and free of dust. Place the gasket in its channel; make sure that its outer edge fits against the cast iron surround ridge.

3. Install the glass. Lay the glass on the inner gasket with the coated side down (toward the outside of the door). Tighten the screws snugly, but loose enough to allow for a little movement of the glass when the stove is in operation. Overtightening can crack the glass immediately or cause it to crack if it is unable to expand when hot.

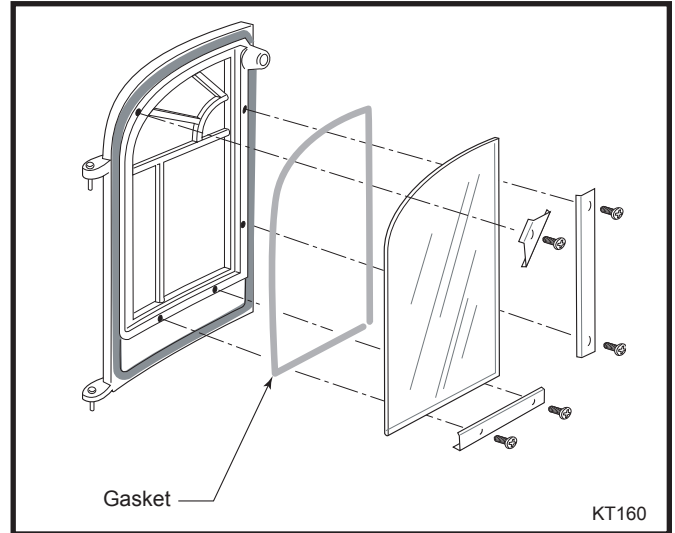

Fig. 39 Door glass installation.

Check the Operation of the Primary Air Shutter

The primary air shutter is visible from the back of the stove. The shutter must open and close freely when you move the thermostat lever. If it does not, check for any obstruction, or for a bound or stretched chain needing adjustment. (Fig. 40)

On a cold stove the shutter should be open no more than 1/8" (3mm) when the primary air control lever is pushed completely to the left (closed), as seen from the back of the stove. When the lever is pushed completely to the right (open), the shutter should be open to an angle of approximately 70 degrees from the stove back.

The ball chain should measure 8 1/2" (216 mm) from connection to the thermostat coil to connection on the primary air flap.

If setting is incorrect, the thermostat coil may be bent or broken. Call your Vermont Castings Dealer for help.

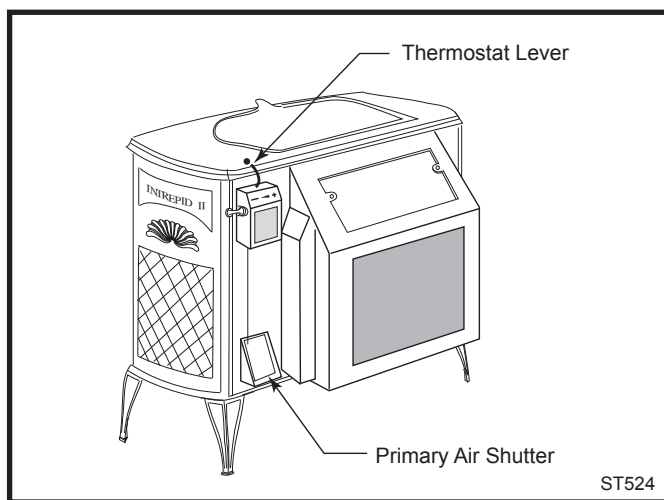

Fig. 40 The primary air shutter must move freely.

How to Adjust the Door Latch

Over time, the gasketing around the doors will compress, and the latch may need adjustment. To adjust the latch, loosen the small locking nut, extend the striker screw one turn while keeping the striker screw from turning. (Fig. 41) Keep making adjustments a little at a time until the setting is right.

The front doors of the stove should close securely and tightly, when the handle is in the closed position. When the latch is properly adjusted there should be a slight resistance as the doors are moved to the completely closed position.

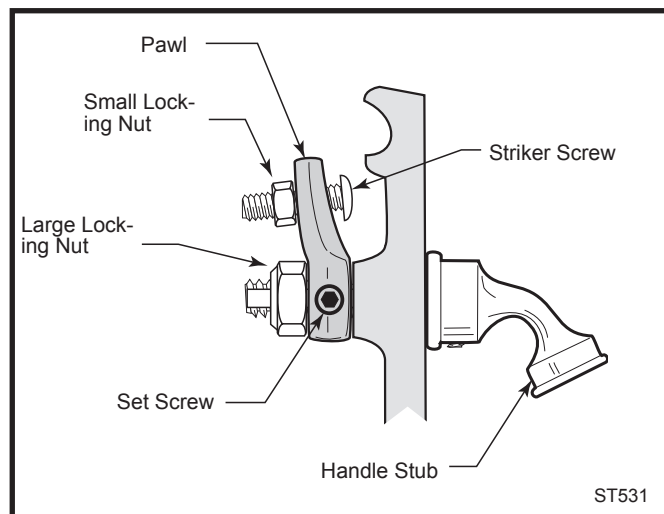

Fig. 41 Turn the door latch striker screw in or out to tighten or loosen the door latch.

Tighten the Damper Handle as Needed

The damper handle is attached to the damper rod with a set screw bearing against a flat spot on the rod. Check the set screw periodically for tightness; tighten as needed.

Damper Adjustment

When the stove damper is closed, the pressure of the rod against the damper plate assures a good seal between the damper and the damper housing. Adjustment may be needed after a period of time to retain adequate pressure.

To make this adjustment, start with the damper in the closed and locked position. (Fig. 42) Loosen the 7/16" locking nut in the center of the damper. Use a 1/8" Allen wrench to turn the Allen screw a full turn clockwise. Test the damper for snugness, and continue adjusting the Allen screw as needed. Tighten the 7/16" locking nut when the damper operates smoothly but firmly.

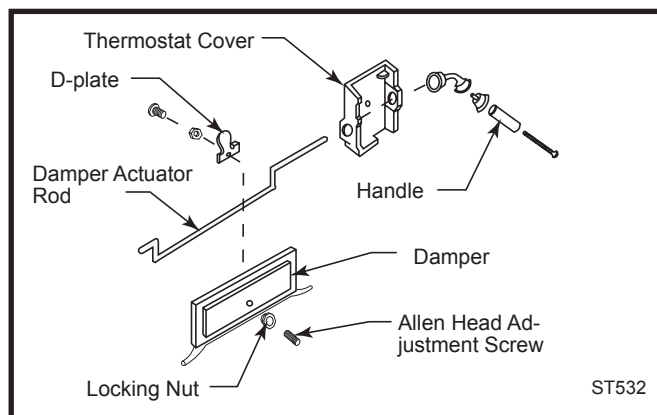

Fig. 42 Tighten the damper adjustment screw for a snug seal.

Replace the Stove Gaskets as Needed

The Intrepid uses fiberglass rope gaskets to make a tight seal between some parts. With use, particularly on those parts that move, gaskets can become brittle and compressed, and can begin to lose their effectiveness. These will need periodic replacement.

The sizes of replaceable gasket are listed below, along with their applications.

Gasket Diameter ... And the Parts it Seals

- | | |
|-------------------|--|
| 5/16" wire gasket | The griddle to the stove top |
| 5/16" | The damper to the upper fire-back; the front doors to the stove front; and the door halves to each other |
| 3/16" | The glass panes to the door |

Refer to Page 27 for information on replacing the glass panels or its gasket.

If you need to change a gasket, first obtain an appropriate replacement from your Vermont Castings Dealer.

Wait until the fire is out and the stove has cooled. Be sure to follow the standard safety procedure for working with dusty materials: Wear safety goggles and a dust mask.

The procedure for replacing the gaskets is the same, regardless of the gasket location.

1. Remove the existing gasket by grasping an end and pulling firmly.
2. Use a wire brush or a screwdriver to clean the channel of any remaining cement or bits of gasket. Remove stubborn deposits of cement with a cold chisel if necessary. (Fig. 43)

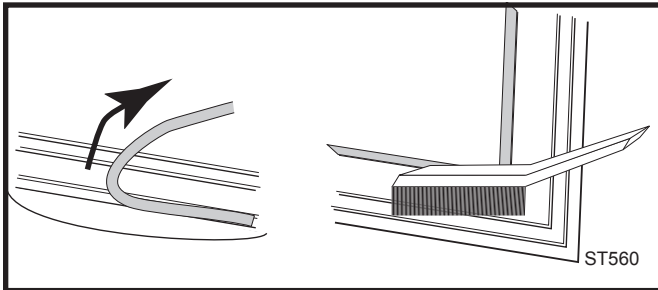

Fig. 43 Remove gasket then clean channel with wire brush.

3. Determine the correct length of the appropriate-sized gasket by laying it out in the channel. Allow an extra 1-2" (25-51 mm) and mark the spot to be cut.
4. Remove the gasket from the channel, place it on a wood cutting surface, and cut it at the marked spot with a utility knife. Twist the ends slightly to keep the gasket from unraveling.
5. Lay an unbroken 1/8" (3 mm) bead of gasket cement in the newly-cleaned channel. Starting at one end, press the gasket into the channel. Ensure a good joint where the gasket meets before trimming any excess. Do not overlap the gasket ends or leave ends with ragged edges. (Fig. 44)
6. Press the gasketed part firmly against its normal mating surface to seat the gasket evenly in its channel.

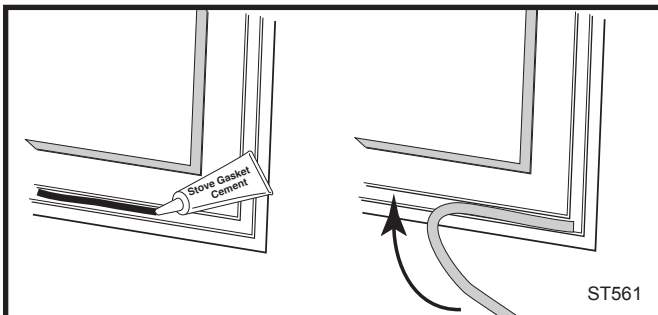

Fig. 44 Lay a bead of gasket cement then press new gasket in place.

7. For doors, replace the doors and close them on a piece of waxed paper to keep the cement from migrating onto the stove front, or tap other parts with the rubber mallet (or hammer/block of wood).
8. Clean excess cement from around the channel. Let the cement that holds the new gasket dry thoroughly.

Adjust the Door if Necessary

The door latch or damper mechanism may need adjustment after you have regasketed them. Initially, it may require loosening to accommodate the new gasket; after a few weeks, it may need tightening to compensate for compression of the new gasket. The directions for adjusting the latch and damper are on page 26.

Permanent Gaskets

Other gaskets seal between non-moving parts, but these are not subject to the same wear and deterioration as gaskets on moving parts. It is unlikely that you will ever need to replace these gaskets unless the involved parts are disassembled and then put back together. If this is the case, the job should be done only by a qualified service technician. The diameter of the gasket that seals these non-moving parts is 5/16", and the areas sealed are the flue collar to the stove back; and the lower fireback to the sides. Refer to Page 26 for information on the glass panels and their gaskets.

The Chimney System

Creosote

Your Intrepid Multi-fuel is designed to reduce creosote buildup significantly. However, regular chimney inspection and maintenance must still be performed. For safety, good stove performance, and to protect your chimney and chimney connector, inspect the chimney and chimney connector on a regular schedule. Clean the system if necessary. Failure to keep the chimney and connector system clean can result in a serious chimney fire.

When wood is burned slowly, it produces tar, organic vapors and moisture that combine to form creosote. The creosote vapors condense in the relatively cool chimney flue. As a result, creosote residue accumulates on the flue lining. When ignited, this creosote makes an extremely hot fire within the flue system that can damage the chimney and overheat adjacent combustible material.

If you do have a chimney fire, act promptly to:

- **Close the damper and thermostat lever.**
- **Get everyone out of the house.**
- **Call the Fire Department.**

You should inspect the system every two weeks during the heating season as part of a regular maintenance schedule. To inspect the chimney, let the stove cool completely. Then, using a mirror and a strong light, sight up through the flue collar into the chimney flue. If it is not possible to inspect the flue system in this fashion the stove must be disconnected to provide better viewing access.

If a significant layer of creosote has accumulated - 1/8" (3mm) or more - remove it to reduce the risk of a chimney fire.

Clean the chimney using a brush the same size and shape as the flue liner. Flexible fiberglass rods are used to run the brush up and down the liner, causing any deposits to fall to the bottom of the chimney where they can be removed through the clean out door.

The chimney connector should be cleaned by disconnecting the sections, taking them outside, and removing any deposits with a stiff wire brush. Reinstall the connector sections after cleaning, being sure to secure the individual sections with sheet metal screws.

If you cannot inspect or clean the chimney yourself, contact your local Vermont Castings, Majestic Products authorized dealer or hire a professional chimney sweep.

Annual Maintenance

Perform a thorough cleaning, inspection and repair each spring, at the end of the heating season.

- Thoroughly clean the chimney and chimney connector.
- Inspect the chimney for damage and deterioration. Replace weak sections of prefabricated chimney. Have a mason make repairs to a masonry chimney.
- Inspect the chimney connector and replace any damaged sections.
- Check gasketing for wear or compression, and replace if necessary. A 'paper test' will guide you on this. Close and lock the door or damper on a slip of paper and then try to pull the paper out. If the paper pulls out with little or no resistance, the gasket is not snug enough at that spot. If adjusting the damper or latch does not result in a seal that makes it hard to pull the paper out, replace the gasketing.
- Check door and damper handles for tightness. Adjust if needed.
- Check heat shield screws. Tighten as necessary.
- Clean dust from the inner sides of bottom, rear and connector heat shields.
- Remove ashes from the ash pan and replace with moisture absorbing material (such as cat litter) to keep the stove interior dry. Close the stove door to keep cats from using the litter.
- Touch up the paint on black stoves.

Please record the following information for future reference.

Stove Serial No. _____

Dealer _____

Phone _____

Date Purchased _____

Installer _____

Phone _____

Date Installed _____

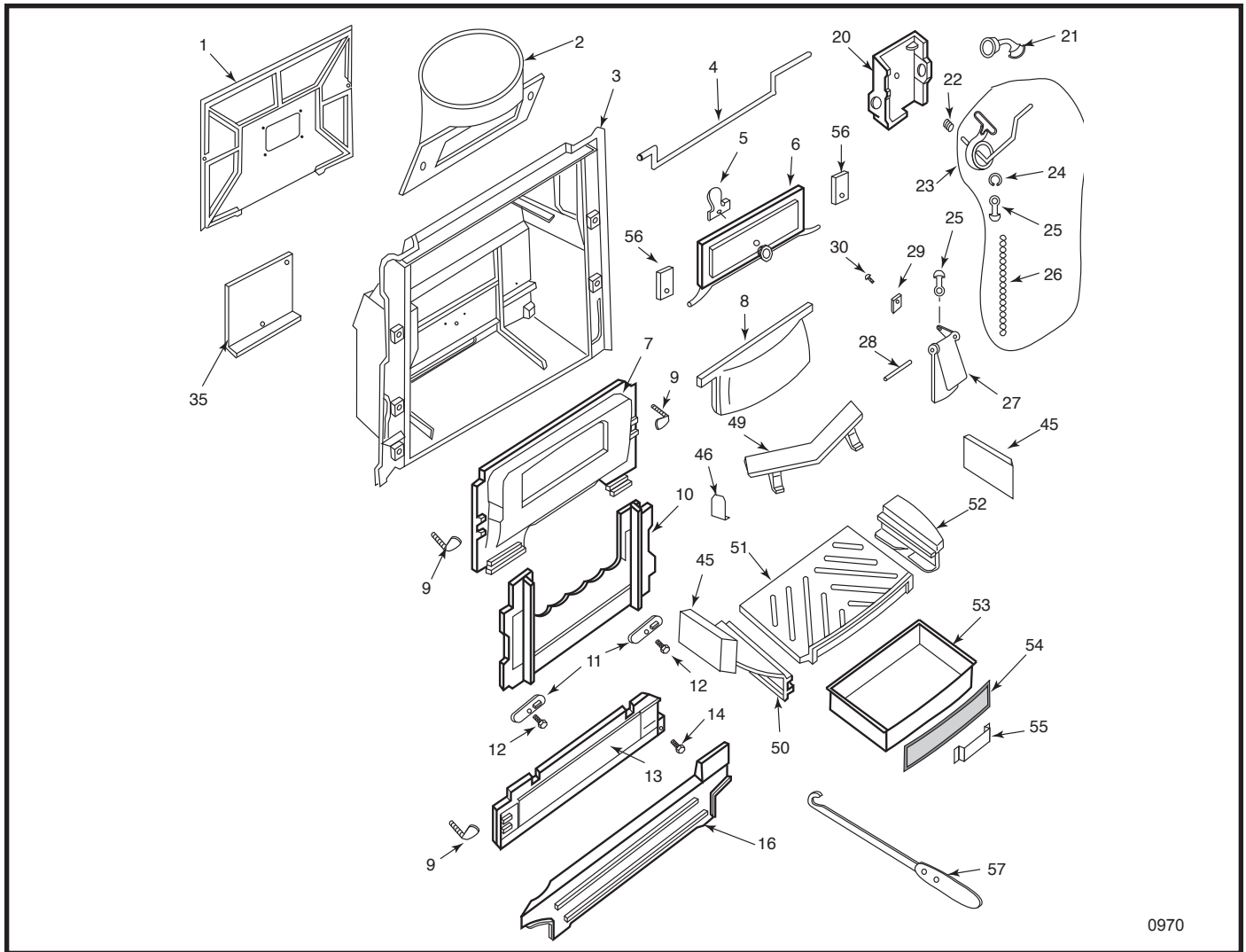

0970

CFM Corporation reserves the right to make changes in design, materials, specifications, prices and discontinue colors and products at any time, without notice.

Intrepid Multi-Fuel Heater

Model 1695

Item Description	Part Number
1. Rear Cover (Sec. Air Cover)	1306762
2. Flue Collar	1306561
3. Back Panel	1308662
4. Damper Rod	1602523
5. Damper D-plate (Damper Clip)	1306725
6. Damper	1306701
7. Damper Housing	1306702
8. Throat Hood	30001649
9. Weld Screw	1201583
10. Upper Firebrick	1306703
11. Fireback Clamp	1306724
12. 3/8" - 16 x 1 1/2" Hex Bolt	1201456
13. Lower Fireback	1306704
16. Rear Air Tube	1308658
20. Thermostat Cover	1306711
21. Damper Handle Stub	5004265
22. Friction Spring	1201846

Item Description	Part Number
23. Thermostat Assy	5005506
24. Thermostat Clip	1601408
25. Ball Chain Fitting (2)	1201972
26. Ball Chain	1201960
Jump Ring	1201985
27. Primary Air Flap	1306710
28. Air Flap Pin	1601551
29. Clip	1601396
30. #10-24 x 3/8" Pan Head Bolt	1200983
35. Cover Plate	1608955
45. Side Brick	1608953
46. Brick Clip	1608956
47. Flue Deflector	1401158
49. Front Grate	1308659
50. Left Insert	1308661
51. Grate	1308652

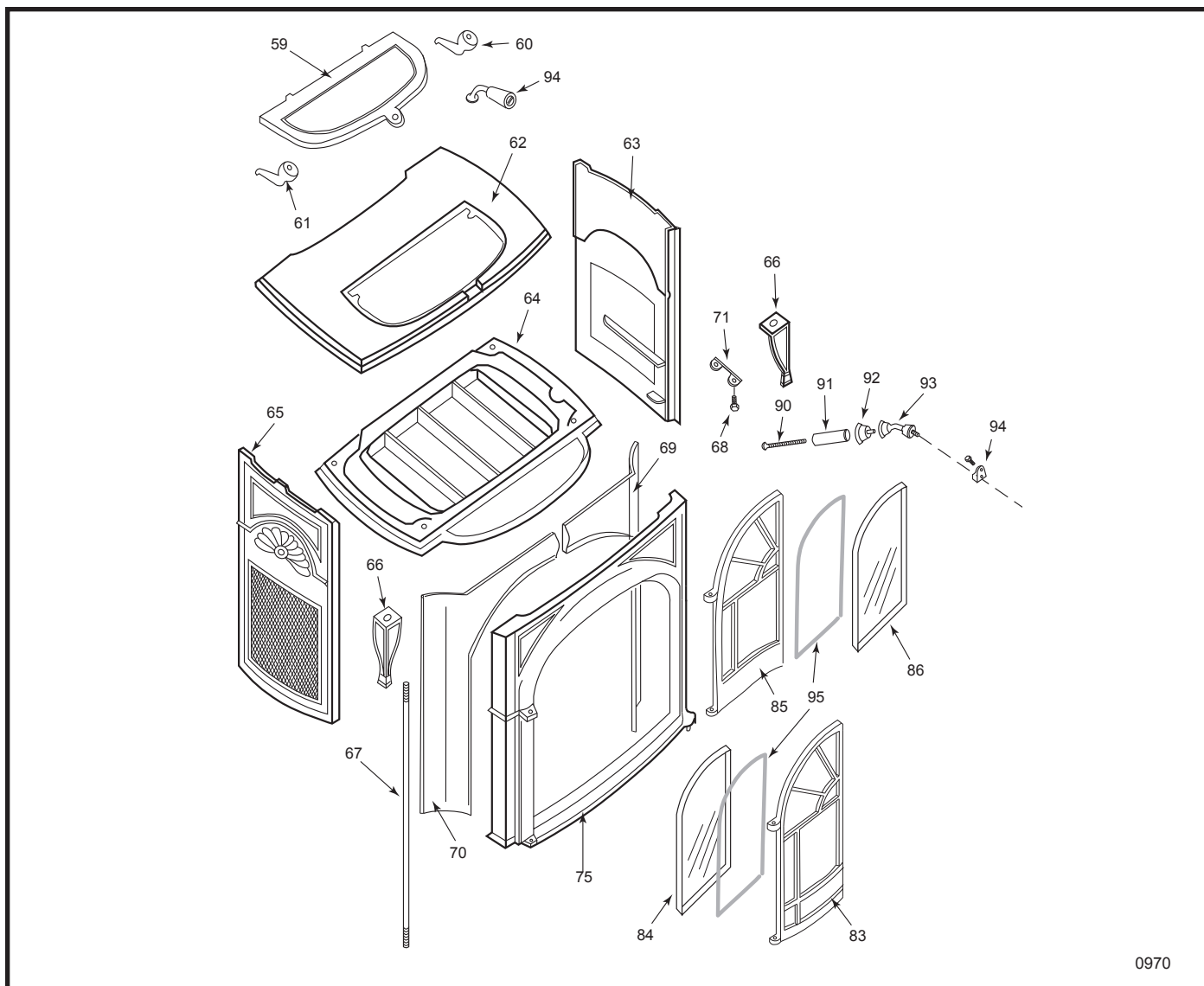

0970

CFM Corporation reserves the right to make changes in design, materials, specifications, prices and discontinue colors and products at any time, without notice.

Intrepid Multi-Fuel Heater Model 1695 (continued)

Item Description	Part Number
52. Right Insert	1308660
53. Ashpan	1400951
54. Ashpan Front	1306493
55. Ashpan Handle	30000973
56. Damper Tab	1601488
57. Slicer/poker	5005708
59. Griddle	1306356
60. Right Griddle Quad	1301832
61. Left Griddle Quad	1301807
62. Top	See Chart Pg. 31
63. Right Side	See Chart Pg. 31
64. Bottom	1306764
65. Left Side	See Chart Pg. 31
66. Leg	See Chart Pg. 31
67. Tie Rod	1601640

Item Description	Part Number
68. Leg Bolt, 3/8"-16 x 1" Hex Bolt	1201432
69. Right Air Manifold	1308654
70. Left Air Manifold	1308653
71. Handle Holder	1600600
75. Front	See Chart Pg. 31
83. Left Door	See Chart Pg. 31
84. Left Glass Panel ²	1401157
85. Right Door	See Chart Pg. 31
86. Right Glass Panel ²	1401156
90. Handle Bolt, 1/4"-20 x 3 3/8"	1201294
91. Ceramic Handle	1600620
92. Handle Insert	1600650
93. Front Door Handle	5004245
94. Griddle Handle Assy	5004022
95. Glass Gasket	1203556

Intrepid Multi-Fuel Heater

Model 1695 (continued)

Shell Enamel Parts - Intrepid Multi-Fuel Model 1695			
Part Name	Classic	Green	Red
Top	1308657	2318657	2328657
Bottom	1306764	2316764	2326764
Left Side	1308656	2318656	2328656
Front	1308647	2318647	2328647
Left Door	1308649	2318649	2328649
Right Door	1308648	2318648	2328648
Single Leg	1306333	2316333	2326333

1. In the diagrams and throughout this manual, 'left' and 'right' mean as you face the stove.
2. The glass panels have a heat-reflective coating on the outside and are not interchangeable.
3. Hardware in this stove is in standard U.S. (inch) sizes. Most hardware items are available at local hardware stores.

Warranty

Limited 3 Year Warranty

CFM Corporation warrants that this woodburning stove will be free of defects in material and workmanship for a period of three years from the date you receive it, except that the catalyst, thermostat assembly, handles, glass door panels, cement, and gasketing shall be warranted as described below.

CFM Corporation will repair or replace, at its option, any part found to be defective upon inspection by a Vermont Castings Authorized Dealer. The customer must return the defective part or the stove, with shipping prepaid, to the Authorized Dealer or pay for any Authorized Dealer in-home travel fees or service charges for in-home repair work. It is the dealer's option whether the repair work will be done in the customer's home or in the dealer's shop. If, upon inspection, the damage is found to be the fault of the manufacturer, repairs will be authorized at no charge to the customer for parts and/or labor.

Any woodburning stove or part thereof that is repaired or replaced during the limited warranty period will be warranted under the terms of the limited warranty for a period not to exceed the remaining term of the original limited warranty or six (6) months, whichever is longer.

Limited 1 Year Warranty

The following parts of the woodburning stove are warranted to be free of defects in material and workmanship for a period of one year from the date you receive it: The thermostat assembly, handles, glass door panels, cement, and gasketing. Any of these items found to be defective will be repaired or replaced at no charge, upon the return of the part with postage prepaid to a Vermont Castings Authorized Dealer.

Any part repaired or replaced during the limited warranty period will be warranted under the terms of the limited warranty for a period not to exceed the remaining term of the original limited warranty or six (6) months, whichever is longer.

Limited Catalyst Warranty

The catalyst will be warranted for a six year period as follows: If the original catalyst or a replacement catalyst proves defective or ceases to maintain 70% of its particulate emission reduction activity (as measured by an approved testing procedure) within 24 months from the date the Intrepid Multi-Fuel is received, the catalyst itself will be replaced free.

From 25 - 72 months a pro-rated credit will be allowed against a replacement catalyst and the cost of labor necessary for its installation at the time of replacement.

For stove purchases made after June 30, 1990, a third year (25 - 36 months) of no charge replacement will be made when combustor failure is due to thermal degradation of the substrate (crumbling of ceramic material). The customer must pay for any in-home travel fees, service charges, or transportation costs for returning the Intrepid Multi-Fuel to the Authorized Dealer.

Amount of Time Since Purchase	Credit Towards Replacement Cost
0 - 24 months	100%
25 - 36 months	50 %
37 - 48 months	30%
49 - 60 months	20%
61 - 72 months	10%

Any replacement catalyst will be warranted under the terms of the catalyst warranty for the remaining term of the original warranty. The purchaser must provide the following information in order to receive a replacement catalyst under the terms of this limited warranty:

1. Name, address and telephone number.
2. Proof of original purchase date.
3. Date of failure of catalyst.
4. Any relevant information or circumstances regarding determination of failure.

5. In addition, the owner must return the failed catalyst.

Exclusions & Limitations

1. This warranty is transferable; however, proof of original retail purchase is required.

2. This warranty does not cover misuse of the Intrepid. Misuse includes overfiring which will result if the Intrepid is used in such a manner as to cause one or more of the plates to glow red. Overfiring can be identified later by warped plates and areas where the paint pigment has burned off. Overfiring in enamel fireplaces is identified by bubbling, cracking, chipping and discoloration of the porcelain enamel finish. CFM Corporation offers no warranty on chipping of enamel surfaces. Inspect your woodburning stove prior to accepting it for any damage to the enamel.

3. This warranty does not cover misuse of the stove as described in the Owner's Guide, nor does it cover any stove which has been modified unless authorized by a CFM Corporation representative in writing. This warranty does not cover damage to the Intrepid Multi-Fuel caused by burning salt saturated wood, chemically treated wood, or any fuel not recommended in the Owner's Guide.

4. This warranty does not cover a stove repaired by someone other than a CFM Corporation Authorized Dealer.

5. Damage to the unit while in transit is not covered by this warranty but is subject to a claim against the common carrier. Contact Vermont Castings Authorized Dealer from whom you purchased your stove or CFM Corporation if the purchase was direct. (Do not operate the stove as this may negate the ability to process the claim with the carrier.)

6. Claims are not valid where the installation does not conform to local building and fire codes or, in their absence, to the recommendations in the Owner's Guide.

7. The salt air environment of coastal areas, or a high-humidity environment, can be corrosive to the porcelain enamel finish. These conditions can cause rusting of the cast iron beneath the porcelain enamel finish, which will cause the porcelain enamel finish to flake off. This warranty does not cover damage caused by a salt air or high-humidity environment.

8. CFM Corporation shall have no obligation to enhance or update any unit once manufactured.

IN NO EVENT SHALL CFM CORPORATION BE LIABLE FOR INCIDENTAL AND CONSEQUENTIAL DAMAGES. ALL IMPLIED WARRANTIES, INCLUDING THE IMPLIED WARRANTIES OF MERCHANTABILITY AND FITNESS, ARE LIMITED TO THE DURATION OF THIS WRITTEN WARRANTY. THIS WARRANTY SUPERCEDES ALL OTHER ORAL OR WRITTEN WARRANTIES.

Some states do not allow the exclusion or limitations of incidental and consequential damages or limitations on how long an implied warranty lasts, so the above limitations may not apply to you. This warranty gives you specific rights and you may have other rights which vary from state to state.

How to Obtain Service

If a defect is noted within the warranty period, the customer should contact a Vermont Castings Authorized Dealer or CFM Corporation if the purchase was direct with the following information:

1. Name, address, and telephone number of the purchaser.
2. Date of purchase.
3. Serial number from the label on the back.
4. Nature of the defect or damage.
5. Any relevant information or circumstances, e.g., installation, mode of operation when defect was noted.

A warranty claim will then start in process. CFM Corporation reserves the right to withhold final approval of a warranty claim pending a visual inspection of the defect by authorized representatives.

CFM Corporation

2695 Meadowvale Blvd. • Mississauga, Ontario, Canada L5N 8A3
800-668-5323 • www.cfmcorp.com