

GARDEN WAY

by **TROY-BILT**

Parts Catalog

3HP, 5HP & 6.5HP Model Tillers

Models

12190 – 3HP

Serial Numbers:
121901100101 - 121901199999

12191 – 5HP

Serial Numbers:
121911100101 - 121911199999

12193 – 6.5HP

Serial Numbers:
121931100101 - 121931199999



Model 12190



Model 12191

HANDLEBARS, CLUTCH CABLES AND HANDLEBAR MOUNTING HARDWARE

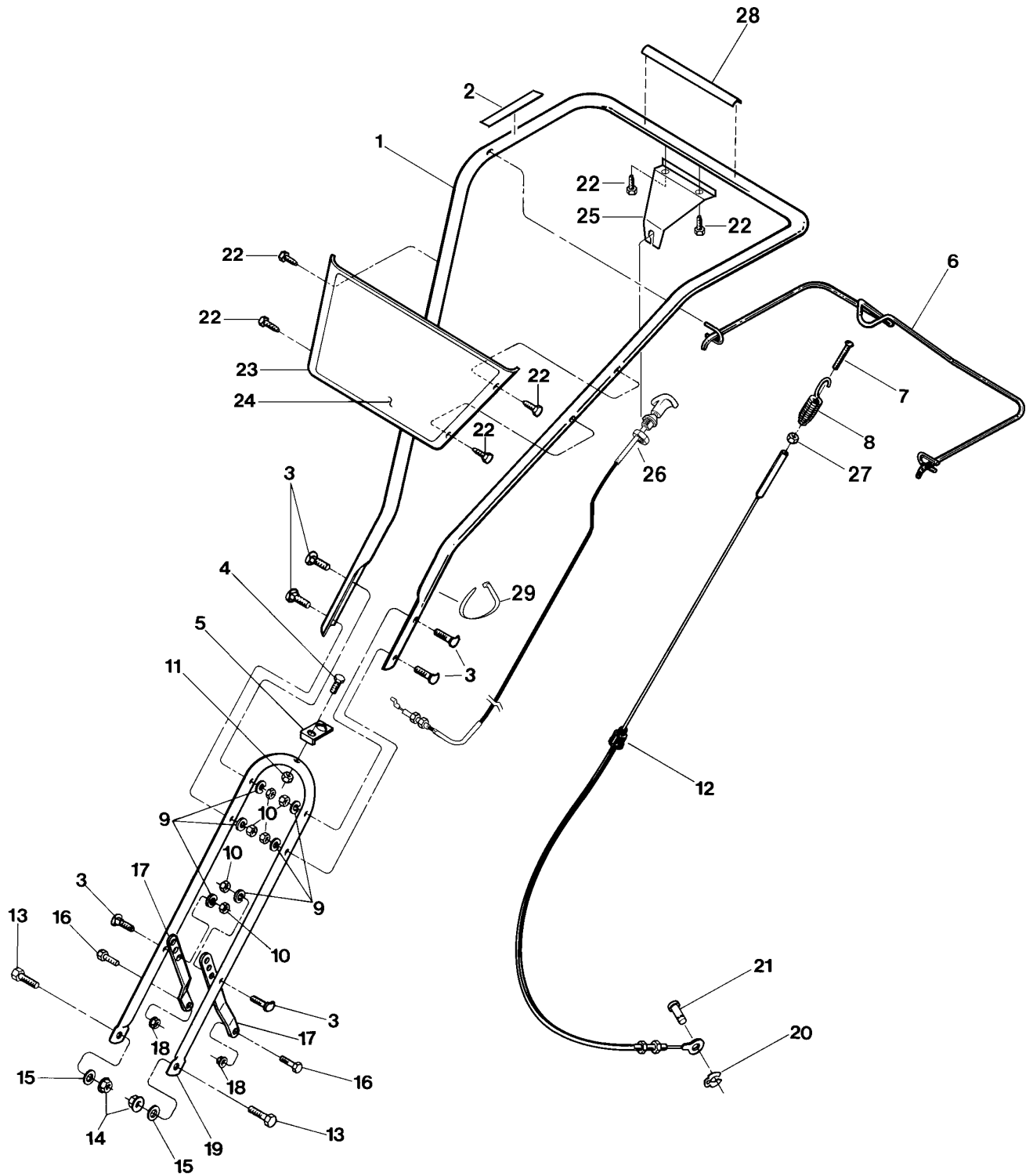

HANDLEBARS, CLUTCH CABLES AND HANDLEBAR MOUNTING HARDWARE

REF No.	PART No.	DESCRIPTION	QTY.	REF No.	PART No.	DESCRIPTION	QTY.
1	1916909	Handlebar, Upper (A) – Incl. Ref. Nos. 2	1	17	1902173001	Support, Handlebar	2
	1916996	Handlebar, Upper (B), (C) – Incl. Ref. Nos. 2 and 28.....	1	18	1110107	Hex Locknut, 5/16-18.....	2
2	1916928	Decal–Forward Clutch Bail	1	19	1902174001	Handlebar, Lower.....	1
3	9854	Curved Hd. Screw, 5/16-18 x 1-1/2	6	20	9386	Klip Ring.....	1
4	1100806	Hex Screw, 1/4-20 x 1-1/4.....	1	21	9856	Clevis Pin.....	1
5	55044	Bracket, Forward Clutch Cable.....	1	22	9552	Hex Screw, 1/4-20 x 1/2, Self-Tapping (A)	4
6	1916106001	Bail, Forward Clutch	1		9552	Hex Screw, 1/4-20 x 1/2, Self-Tapping (B), (C)	6
7	9855	Screw, #10-24 x 2	1	23	1901273001	Panel	1
8	1916712	Spring, Forward Clutch.....	1	24	1916923	Decal–Model Name/Logo (A)	1
9	1100242	Lockwasher, 5/16	6		1916924	Decal–Model Name/Logo (B)	1
10	1186230	Hex Nut, 5/16-18	6		1916925	Decal–Model Name/Logo (C).....	1
11	9811	Hex Locknut, 1/4-20	1	25	1916674001	Bracket, Reverse Clutch Cable (B), (C)	1
12	55048	Cable Assembly, Forward Clutch ...	1	26	1916719	Cable Assembly, Reverse Clutch (B), (C)	1
13	1100068	Hex Screw, 3/8-16 x 3/4	2	27	1186227	Hex Nut, #10-24	1
14	9837	Hex Locknut, 3/8-16	2	28	1916929	Decal–Reverse Drive Control (B), (C)	1
15	1107383	Flat Washer, 3/8.....	2	29	1735531	Cable Tie (B), (C)	2
16	1100044	Hex Screw, 5/16-18 x 3/4	2				

- (A) Model 12190 – 3HP
- (B) Model 12191 – 5HP
- (C) Model 12193 – 6.5 HP

HOOD, BRACKET AND DEPTH REGULATOR

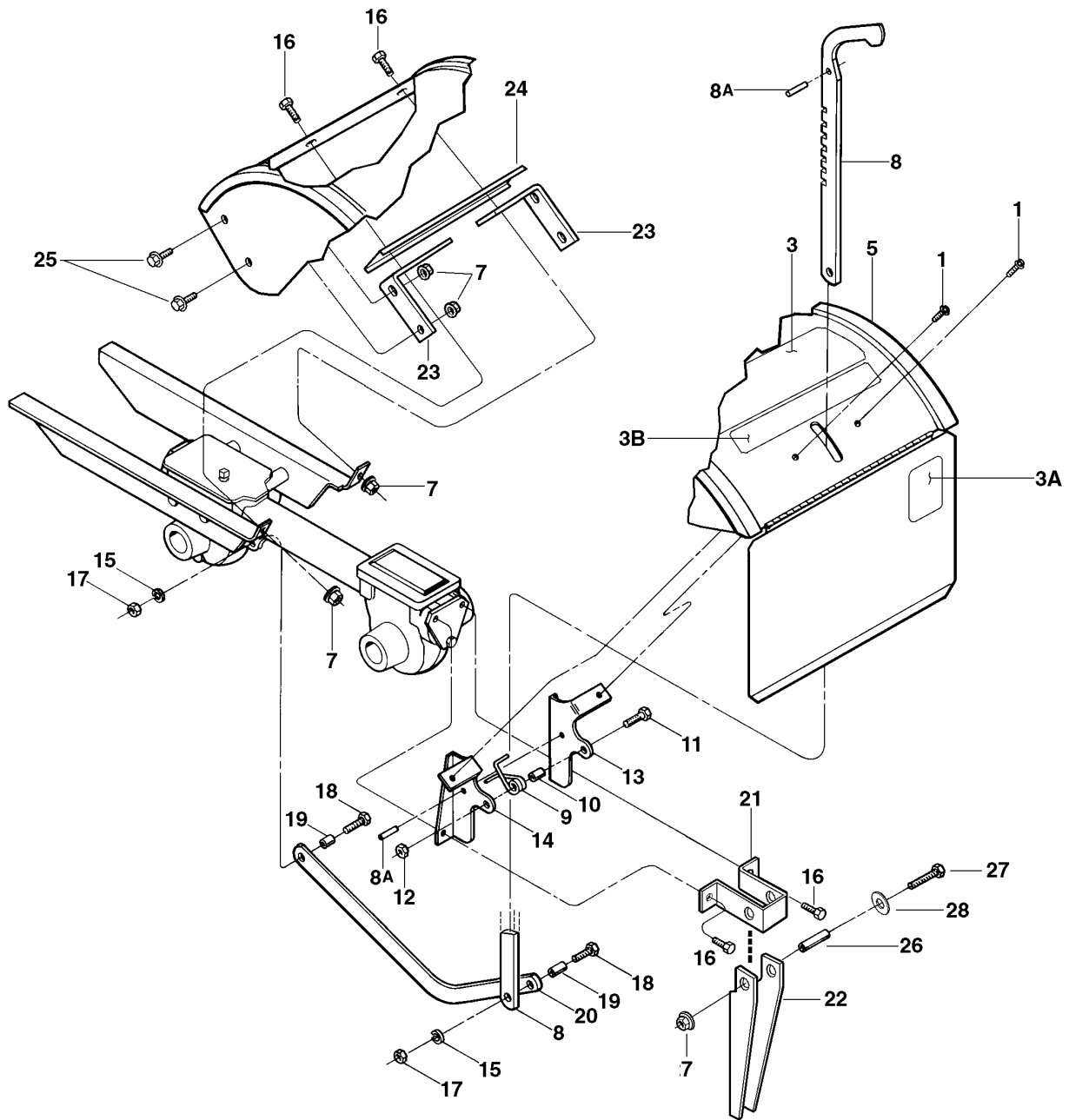

HOOD, BRACKET AND DEPTH REGULATOR

REF No.	PART No.	DESCRIPTION	QTY.	REF No.	PART No.	DESCRIPTION	QTY.
1	9552	Bolt–Fl. Hd., Self-Tap, 1/4-20 x 1/2	2	13	1916119001	Bracket–Hood, Right Hand.....	1
3	1916805	Decal–Hood	1	14	1916120001	Bracket–Hood, Left Hand	1
3A	1911361	Decal–Warning.....	1	15	11000242	Lockwasher, 5/16	2
3B	1916919	Decal–Logo.....	1	16	1186331	Bolt–Flanged Hd., 5/16-18 x 1	4
5	1917121	Tine Hood, (A) –Includes tine flap and Ref. No. 3, 3A, and 3B	1	17	1186230	Nut–Hex Hd., 5/16-18	2
	1917120	Tine Hood (B), (C) –Includes tine flap and Ref. No. 3, 3A, and 3B	1	18	1100808	Bolt–Hex Hd., 5/16-18 x 1-1/4	2
6		(Ref. No. Not Used)		19	55088	Bushing–Drag Bar	2
7	1186391	Nut–Flange Lock, 5/16-18.....	9	20	1916121001	Drag Bar.....	1
8	1916118001	Depth Regulator Lever	1	21	1916569001	Bracket– Stop	1
8A	9308	Spirol Pin	2	22	1916570001	Arm– Reverse (Drag Stake)	1
9	9384	Spring–Depth Regulator	1	23	1916708001	Bracket– Hood Support.....	2
10	9534	Spacer	1	24	1916707001	Bracket– Support Channel	1
11	1100069	Bolt–Hex Hd., 1/4-20 x 1.....	1	25	1186328	Bolt– Hex Hd. 5/16-18 x 5/8.....	6
12	9811	Locknut–Hex Hd., 1/4-20	1	26	1916771	Spacer.....	1
				27	1111607	Bolt– Hex Hd. 5/16-18 x 2-1/4	1
				28	1107382	Washer– 5/16 I.D.....	1

- (A) Model 12190 – 3HP
- (B) Model 12191 – 5HP
- (C) Model 12193 – 6.5 HP

ENGINE, ENGINE BRACKETS, AND FORWARD DRIVE MECHANISM
Model 12190

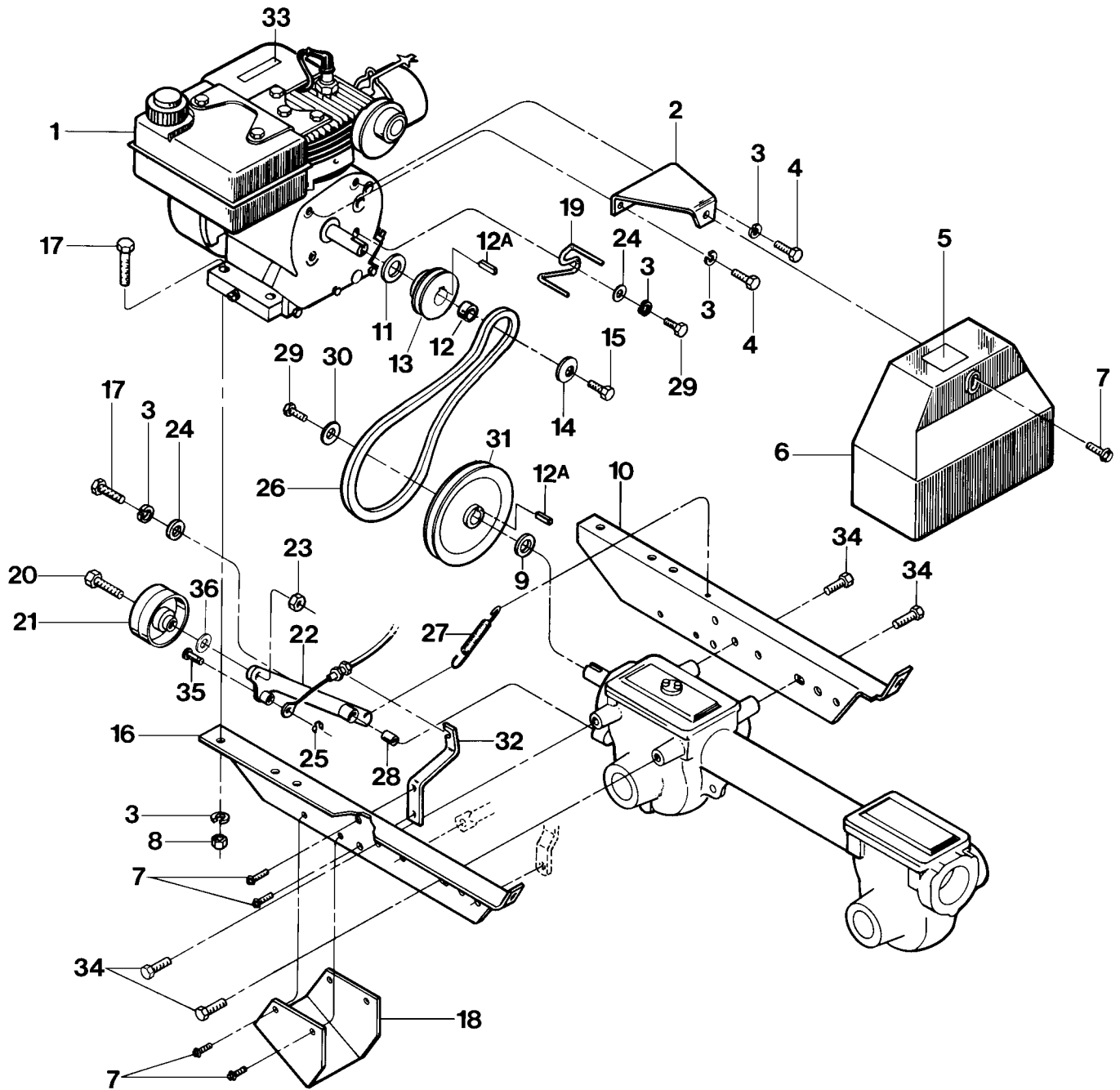

**ENGINE, ENGINE BRACKETS, AND FORWARD DRIVE MECHANISM
Model 12190**

REF No.	PART No.	DESCRIPTION	QTY.	REF No.	PART No.	DESCRIPTION	QTY.
1	*	Engine 3HP, recoil start	1	20	9558	Bolt-Hex Hd., 3/8-16 x 1-1/2	1
2	1916537001	Bracket, Belt Cover	1	21	9090	Idler Pulley	1
3	1100242	Lockwasher-5/16	8	22	1916116001	Idler Lever	1
4	1111696	Bolt-Hex Hd., 5/16-24 x 1/2	2	23	1110108	Locknut - 3/8-16	1
5	1904557	Decal-Warning, Hot Surfaces	1	24	1107382	Washer, Flat	2
6	1917128	Belt Cover-(includes decal 1904557)	1	25	9386	Klip Ring	1
7	9552	Bolt-Flanged Hd., Self-Tapping, 1/4-20 x 1/2	7	26	1916657	V-Belt	1
8	1186230	Nut-Hex Hd., 5/16-18"	4	27	55034	Spring, Return	1
9	50027	Support Washer	1	28	55033	Bushing-Idler Lever	1
10	1916795001	Bracket, Engine, Right	1	29	1100004	Bolt-Hex Hd., 5/16-24 x 3/4, Grade 5	2
11	1138-2	Shim	A/R	30	9944	Washer, Belleville, Transmission Pulley	1
12	1916574	Spacer	1	31	1911321	Pulley-Transmission	1
12A	9301	Key-3/16 x 1	2	32	1916117001	Bracket-Cable Mount	1
13	1911322	Pulley, Engine Driven	1	33	1900766	Decal-Stabilization	1
14	9925	Washer, Belleville	1	34	1186328	Bolt-5/16-18 x 5/8, Engine Bracket to Transmission	4
15	1100009	Bolt-Hex Hd., 3/8-24 x 1	1	35	9856	Clevis Pin-Control Cable	1
16	1916794001	Bracket, Engine, Left	1	36	1107383	Washer-flat, 3/8	1
17	1100799	Bolt-Hex Hd., 5/16-18 x 1-1/2	5				
18	1916652001	Belt Pulley Guard	1				
19	1916706	Belt Guide	1				

A/R – As Required

* See your local authorized engine service dealer for engine parts or service. Refer to the engine nameplate for engine type and code information.

ENGINE, ENGINE BRACKETS AND BELT DRIVE SYSTEMS
Models 12191 and 12193

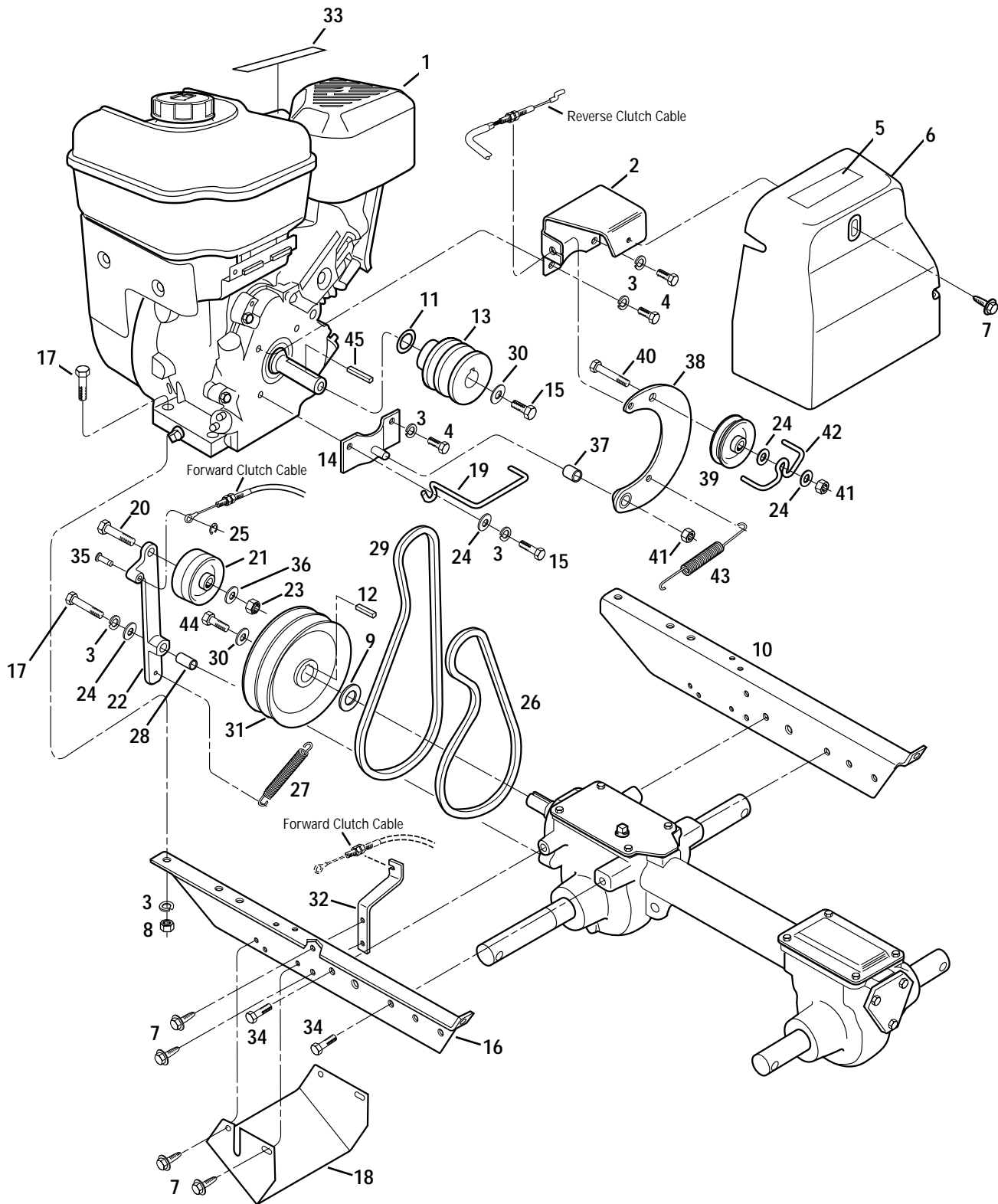

ENGINE, ENGINE BRACKETS AND BELT DRIVE SYSTEMS
Models 12191 and 12193

REF No.	PART No.	DESCRIPTION	QTY.	REF No.	PART No.	DESCRIPTION	QTY.
1	*	Engine – 5HP & 6.5HP, Recoil Start.....	1	23	1110108	Locknut – 3/8-16	1
2	1916537001	Bracket, Belt Cover.....	1	24	1107382	Washer, Flat	2
3	1100242	Lockwasher, 5/16	9	25	9386	Klip Ring	1
4	1111696	Screw, Hex Hd., 5/16-24 x 1/2	3	26	1916657	Forward Drive Belt	1
5	1904557	Decal–Warning, Hot Surfaces	1	27	55034	Spring, Forward Return.....	1
6	1917128	Belt Cover (Incl. Ref. 5).....	1	28	55033	Bushing, Forward Idler Lever	1
7	9552	Flange Screw, Self-Tapping, 1/4-20 x 1/2.....	7	29	1916658	Reverse Drive Belt.....	1
8	1186230	Hex Nut, 5/16-18.....	4	30	9944	Washer, Belleville	1
9	50027	Support Washer	1	31	1916532	Pulley, Transmission	1
10	1916795001	Engine Bracket, Right	1	32	1916117001	Bracket, Cable Mounting.....	1
11	1138-2	Shim	A/R	33	1900766	Decal–Stabilization.....	1
12	9301	Key, 3/16 x 1	1	34	1186328	Hex Screw, 5/16-18 x 5/8.....	4
13	1916531	Pulley, Engine Drive	1	35	9856	Clevis Pin	1
14	1916559001	Bracket, Reverse Idler	1	36	1107383	Flat Washer, 3/8	1
15	1100005	Hex Screw, 5/16-24 x 1	3	37	1916536	Bushing.....	1
16	1916794001	Engine Bracket, Left	1	38	1916578001	Reverse Idler Arm	1
17	1100799	Hex Screw, 5/16-18 x 1-1/2	5	39	1916535	Pulley, Reverse Idler	1
18	1916652001	Guard, Belts/Pulleys.....	1	40	1111606	Hex Screw, 5-16-18 x 2.....	1
19	1916726	Belt Guide, Forward.....	1	41	1110107	Locknut, 5-16-18	2
20	9558	Hex Screw, 3/8-16 x 1-1/2	1	42	1916725	Belt Guide	1
21	9090	Forward Idler Pulley	1	43	1916724	Spring, Reverse Return.....	1
22	1916116001	Forward Idler Lever	1	44	9572	Hex Screw, 5/16-18 x 1-1/8	1
				45	1108841	Key, 3/16 x 1-1/2.....	1

A/R – As Required

* Contact your local authorized engine service dealer for engine parts and service. Refer to your engine nameplate for engine model/type number.

DRIVE SHAFT ASSEMBLY

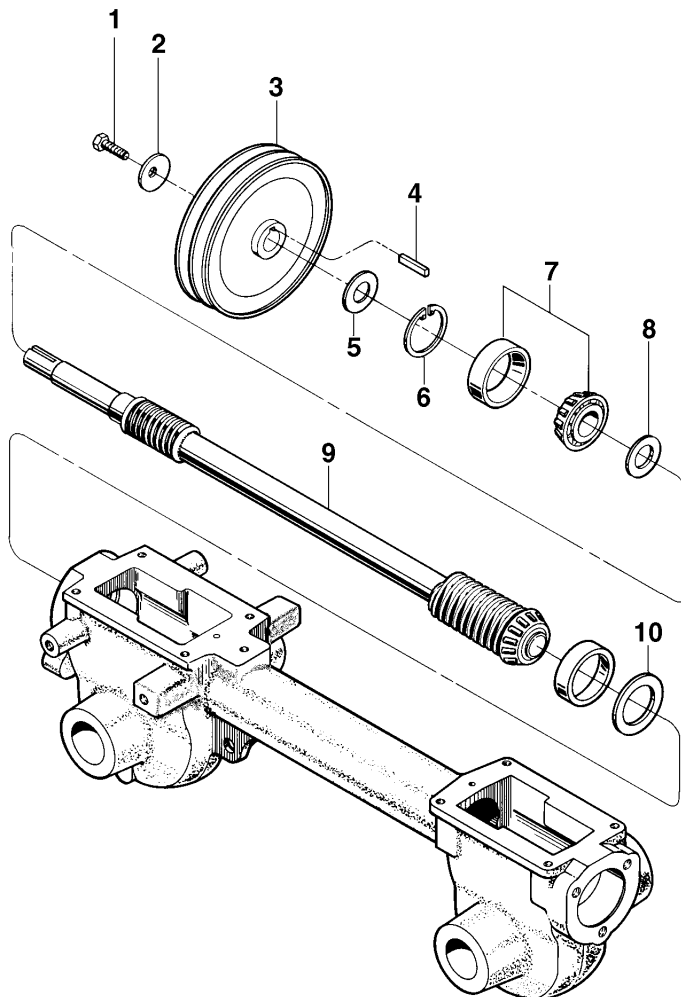

REF No.	PART No.	DESCRIPTION	QTY.
1	1100004	Hex Screw, (A) 5/16-24 x 3/4 Grade 5	1
1	1100005	Hex Screw, (B), (C) 5/16-24 x 1 Grade 5	1
2	9944	Washer, Belleville	1
3	1911321	Single Groove Pulley, (A) Transmission	1
3	1916532	Double Groove Pulley, (B), (C) Transmission	1
4	9301	Key-Transmission Pulley, 3/16 x 1..	
5	50027	Support Washer, Front	1
6	9517	Snap Ring	1
7	1714	Bearing, Tapered Roller (with race).	2

REF No.	PART No.	DESCRIPTION	QTY.
8	50043	Support Washer, Rear	1
9	1916936	Drive Shaft Assembly	1
10	1224-1	Shim, Rear Bearing Cap, .010 thick	A/R
	1224-2	Shim, Same as above except .030 thick	A/R
	1224-3	Shim, Same as above except .005 thick	A/R
	1224-4	Shim, Same as above except .062 thick	A/R
	1325C	Shim Set-Includes the following shims: two #1224-1, two 1224-2, one 1224-3, and one #1224-4	A/R

A/R – As Required

(A) Model 12190 – 3HP

(B) Model 12191 – 5HP

(C) Model 12193 – 6.5 HP

WHEEL AND TILLER SHAFT ASSEMBLIES

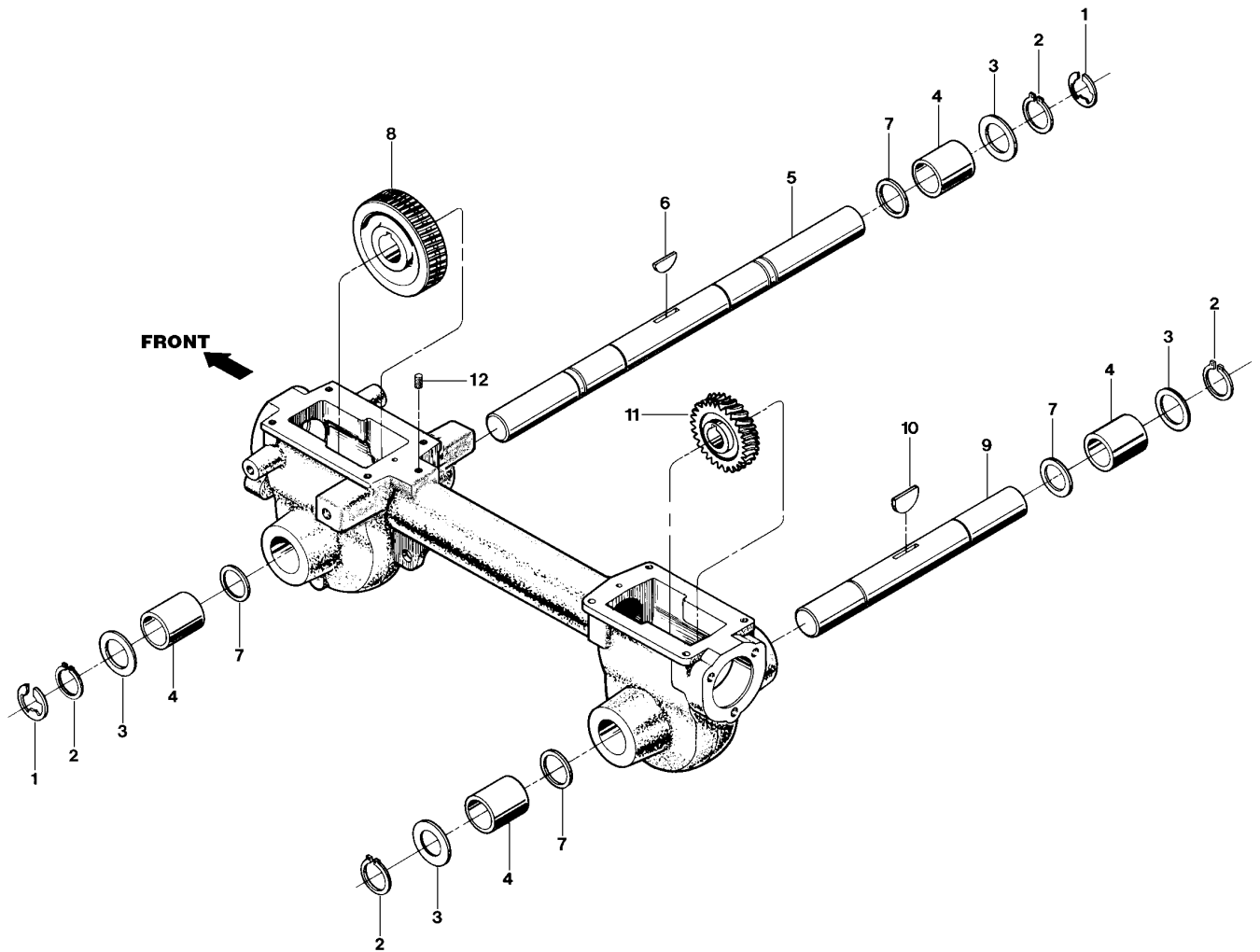

REF No.	PART No.	DESCRIPTION	QTY.
1	9512	Retainer, Snap Ring, "E" Type	2
2	9511	Retainer, Snap Ring	4
3	1166-1	Shim, 0.062" Thick	A/R
	1166-2	Shim, 0.030" Thick	A/R
	1166-3	Shim, 0.015" Thick	A/R
	1166-4	Shim, 0.010" Thick	A/R
	1166-5	Shim, 0.005" Thick	A/R
4	1086	Bushing, Bronze	4

REF No.	PART No.	DESCRIPTION	QTY.
5	1916722	Wheel Shaft (A)	1
5	1916741	Wheel Shaft (B)	1
5	1916739	Wheel Shaft (C)	1
6	9305	Key, Hi Pro, 1/4 x 1	1
7	1132-2	Spacer	4
8	1904278	Worm Gear, Wheel Shaft	1
9	1915074	Tiller Shaft	1
10	1104	Woodruff Key, Tiller Shaft	1
11	1916542	Worm Gear, Tiller Shaft	1

A/R – As Required

(A) Model 12190 – 3HP

(B) Model 12191 – 5HP

(C) Model 12193 – 6.5 HP

TRANSMISSION HOUSING, COVERS, SEALS, GASKETS AND PLUG

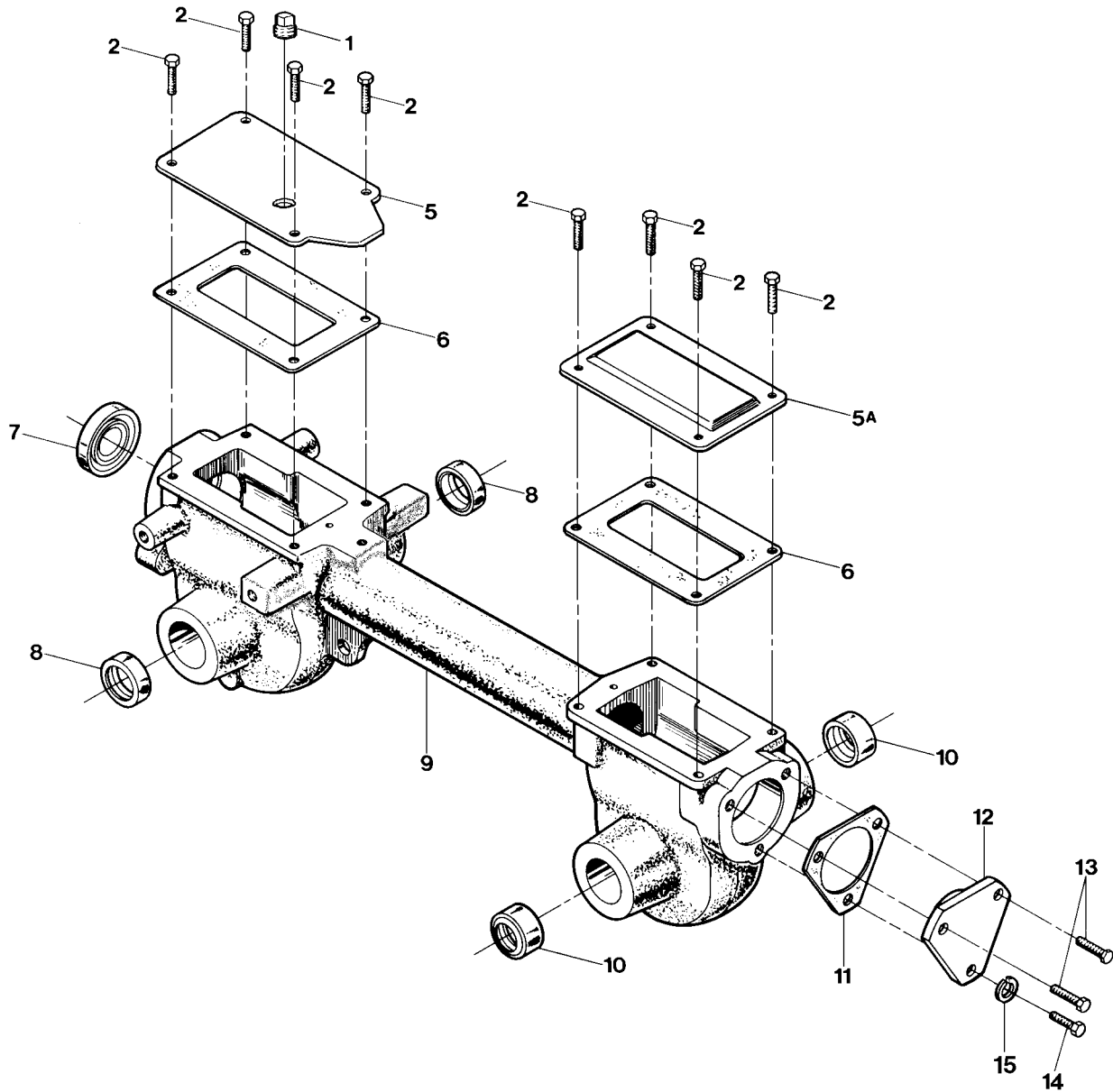

TRANSMISSION HOUSING, COVERS, SEALS, GASKETS AND PLUG

REF No.	PART No.	DESCRIPTION	QTY.	REF No.	PART No.	DESCRIPTION	QTY.
1	9727	Plug, Transmission Oil Fill.....	1	9	1916975001	Transmission Case, Rear Housing and Tube Assembly	1
2	1186328	Flange Screw, Grade 5, 5/16-18 x 5/8.....	8	10	1909374	Oil Seal, Tine Shaft	2
5	1916641001	Front Cover, Trans. Housing	1	11	55011-1	Gasket, Bearing Cap (.010 thick) ..	1
5A	50074	Rear Cover, Trans. Housing	1		55011-2	Gasket, Bearing Cap (.030 thick)...	1
6	50032	Gasket, Trans. Housing Cover (Front and Rear)	2	12	1916111001	Cap, Rear Bearing	1
7	9617	Oil Seal, Drive Shaft	1	13	1186331	Flange Screw, 5/16-18 x 1	2
8	9621	Oil Seal, Wheel Shaft.....	2	14	1100044	Flange Screw, 5/16-18 x 3/4	1
				15	1100242	Lockwasher, 5/16	1

TINES

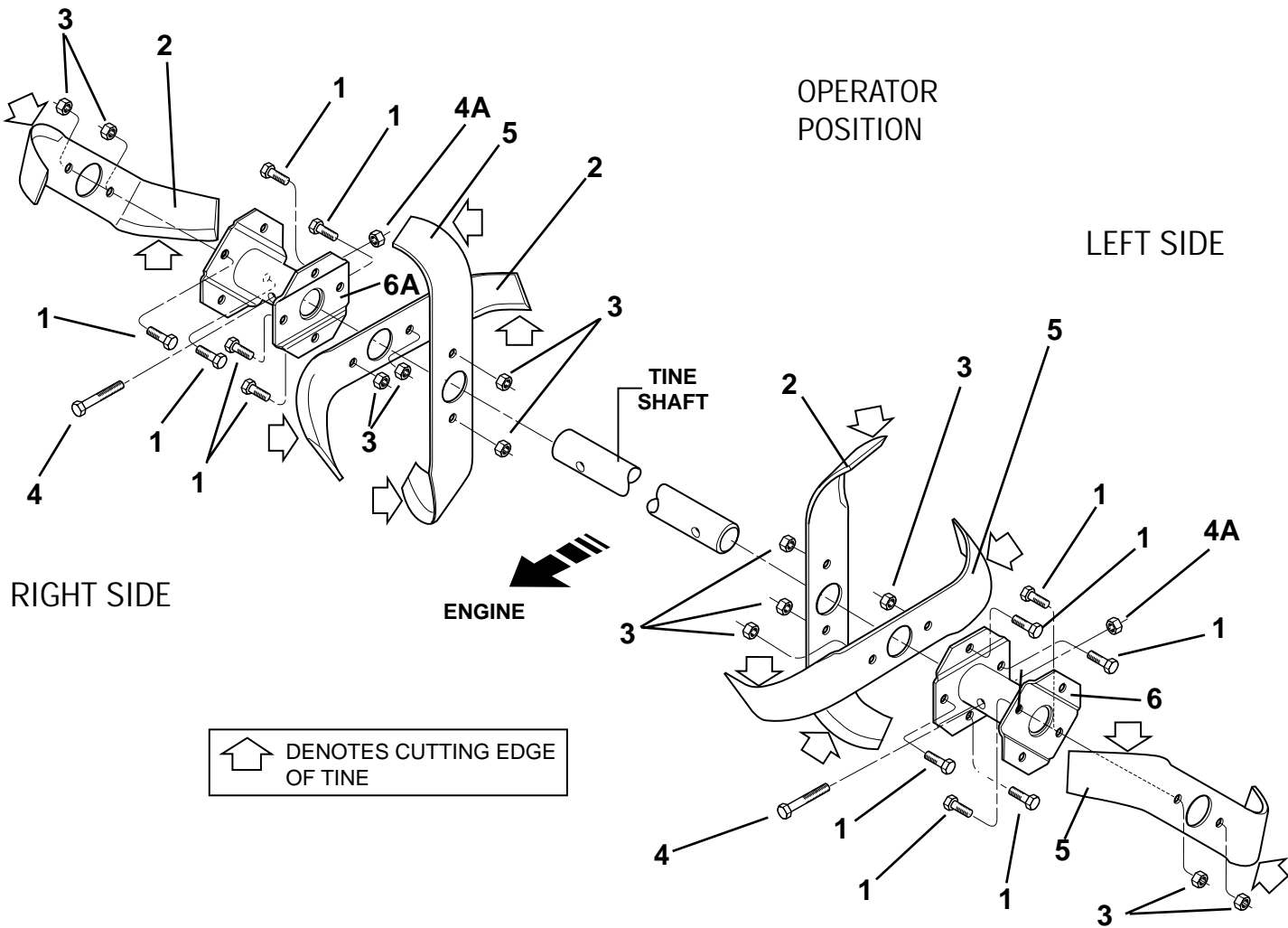

WHEELS

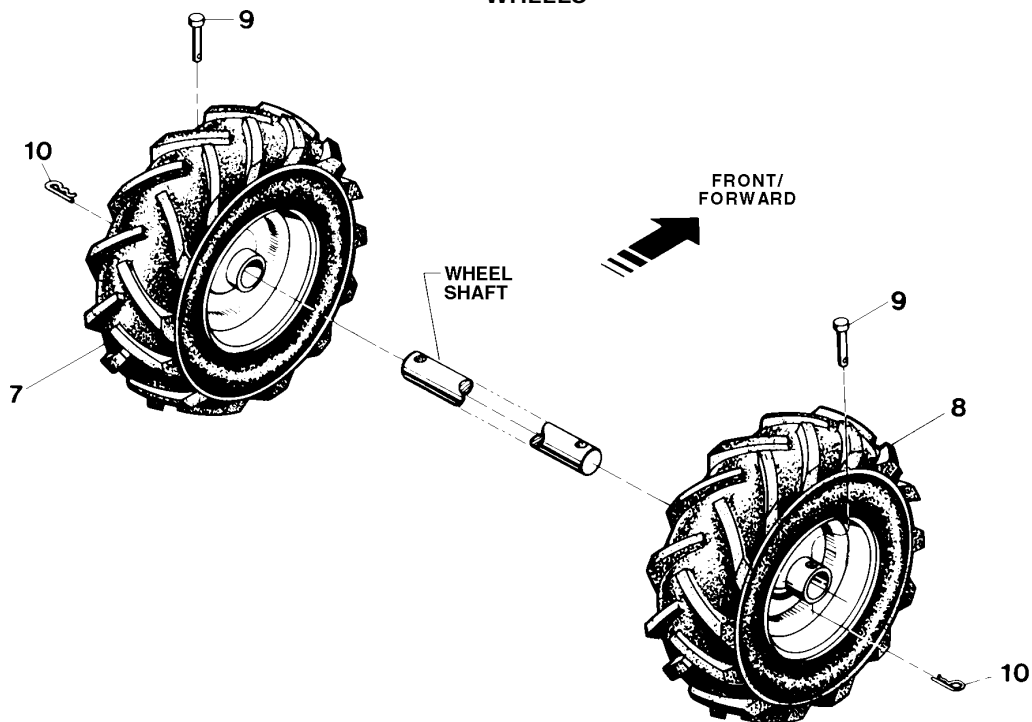

TINES, WHEELS

REF No.	PART No.	DESCRIPTION	QTY.	REF No.	PART No.	DESCRIPTION	QTY.
1	1100044	Bolt-Hex Head, 5/16-18 x 3/4, Grade 5, Tine Mounting	12	6A	1916692001	Tine Holder- right side (A)	1
2	1817060	Tine-Twin-Edged, Left-Facing	3		1916703001	Tine Holder- right side (B)	1
3	1732499	Locknut-Hex Hd., 5/16-18	12		1916705001	Tine Holder- right side (C)	1
4	1982612	Bolt-Hex Hd., 3/8-16 x 2 (tine holder to tiller shaft)	2	7	55095-01	Wheel & Tire Assy-Left Side (A) ...	1
----	1916783	Replacement Set of 6 Tines- including three right-facing tines, three left-facing tines; and all required assembly hardware	1		20918-01	Wheel & Tire Assy-Left Side (B) ...	1
4A	1733398	Locknut- Hex Hd., 3/8-16	2		2706-01	Wheel & Tire Assy-Left Side (C) ...	1
5	1817059	Tine-Twin-Edged, Right-Facing	3	8	55095-02	Wheel & Tire Assy-Right Side (A) ...	1
6	1916691001	Tine Holder- left side (A)	1		20918-02	Wheel & Tire Assy-Right Side (B) ...	1
	1916702001	Tine Holder- left side (B)	1		2706-02	Wheel & Tire Assy-Right Side (C) ...	1
	1916704001	Tine Holder- left side (C)	1	9	9380	Clevis Pin-.312 x 1-3/4, secures wheel hub to wheel shaft	2
				10	9338	Hair Pin Cotter	2

- (A) Model 12190 – 3HP
- (B) Model 12191 – 5HP
- (C) Model 12193 – 6.5 HP

IMPORTANT: LEFT AND RIGHT SIDES OF TILLER ARE DETERMINED BY STANDING IN THE OPERATOR POSITION (BEHIND THE HOOD) AND FACING THE DIRECTION OF FORWARD TRAVEL.

MOUNT TINES SO THE CUTTING EDGE AT THE TOP OF EACH TINE FACES THE OPERATOR

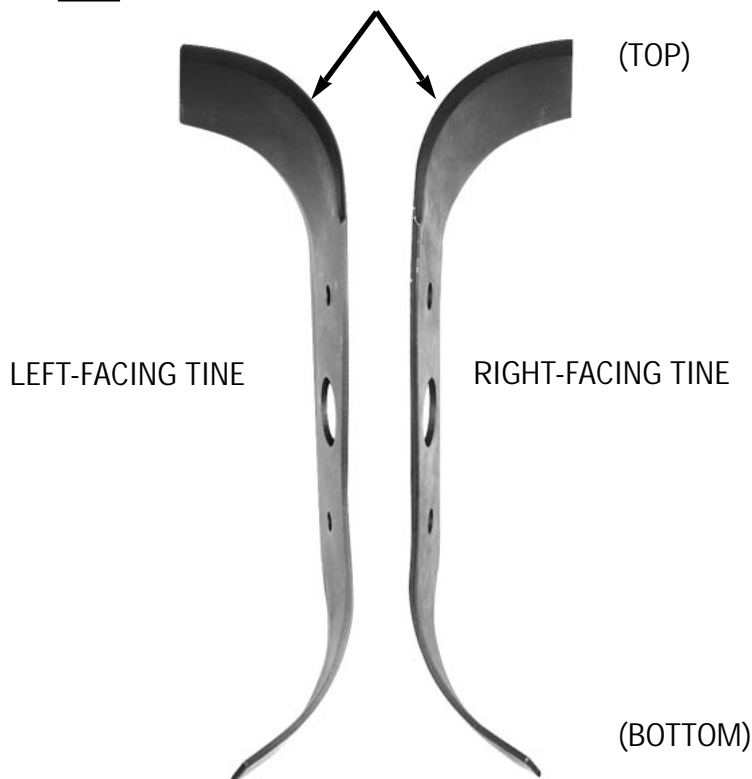

Parts Ordering Information

If you need service or parts:

For service assistance or parts, contact your local authorized dealer or the factory.

Your local dealer or service department will need to know the model/serial numbers of the unit to provide the most efficient service. See below for information on how to identify and record the identification numbers for the unit.

If you need engine service or parts:

For engine service or parts, contact your local authorized engine dealer. Look in the yellow pages of the phone book under "Engines-Gasoline" for the name of your nearest authorized engine dealer. An authorized engine dealer can handle all parts, repairs, and warranty service concerning the engine.

Note:

All replacement parts must conform to our rigid quality specifications. Although some replacement parts we provide may vary slightly in shape, color or texture from the original parts, any variations will not affect the fit or performance of these parts on your unit.



WARNING

We urge using only genuine replacement parts which meet all the latest requirements. Replacement parts manufactured by others could present safety hazards, even though they may fit on the unit!

IMPORTANT:

Left and right sides of the unit are determined by standing behind the unit, in the operator's position, and facing in the direction of forward travel.

NOTICE:

We reserve the right to change specifications, add improvements or discontinue the manufacture of any of our equipment without notice or obligation to purchasers of our equipment.

Identification Numbers

Record the Model/Serial Numbers here:

When ordering parts from us or your local servicing dealer, you will need to provide the unit's model/serial number. For your convenience and ready reference, record this information below.

Product Model/Serial Number _____

Engine Model/Serial Spec. Numbers _____

Date of Purchase _____

Name of Dealer _____

For customer assistance, contact your nearest authorized dealer or:

GARDEN WAY INCORPORATED • 1 Garden Way • Troy, New York 12180
Customer Service: 1-800-437-8686 • Technical Service: 1-800-520-5520 • Parts Service: 1-800-648-6776
• FAX: (518) 391-7332 • WEBSITE: www.troybilt.com

Outside the United States and Canada:

Customer Service: (518) 391-7007 • Technical Service: (518) 391-7008 • Parts Service: (518) 391-7006 • FAX (518) 391-7332