



3825 Ohio Avenue, St. Charles, Illinois 60174  
 1-800-SENSOR2, FAX: 630-377-6495  
 www.systemsensor.com

# 1400 Direct Wire Ionization Smoke Detector

**Specifications**

Diameter: 5.5 inches (140 mm)  
 Height: 3.12 inches (80 mm)  
 Weight: 0.7 lb. (310 g)  
 Operating Temperature: 0°C to +49°C (32°F to 120°F)  
 Latching Alarm: Reset by momentary power interruption.  
 Operating Humidity: 10% to 93% Relative Humidity, Noncondensing

**Electrical Ratings:**

System Voltage: 12/24 VDC  
 Maximum Ripple Voltage: 4 Volts peak to peak  
 Start-up Capacitance: 0.02  $\mu$ A Maximum  
 Standby Ratings: 8.5 VDC Minimum  
 35 VDC Maximum  
 100  $\mu$ A Maximum

**Alarm Ratings:**

4.2 VDC Minimum at 10 mA  
 6.6 VDC Minimum at 100 mA  
 Alarm current must be limited to 100 mA maximum by the control panel. If used, the RA400Z Remote Annunciator operates within the specified detector alarm currents.

Reset Voltage: 2.5 VDC Minimum  
 Reset Time: 0.3 S Maximum  
 Start-up Time: 35 S Maximum

**Before Installing**

Please thoroughly read the System Sensor manual A05-1003, *Applications Guide for System Smoke Detectors*. This manual provides detailed information on detector spacing, placement, zoning, wiring, and special applications. Copies of this manual are available at no charge from System Sensor. (For installation in Canada, refer to CAN/ULC-S524, *Standard for the Installation of Fire Alarm Systems* and CEC Part 1, Sec. 32.)

**General Description**

System Sensor 1400 dual-chamber ionization smoke detectors utilize state-of-the-art, unipolar sensing chambers. These detectors are designed to provide open area protection, and to be used with compatible UL-listed, 2-wire control panels only. The detector's operation and sensitivity can be tested in place.

Each detector includes an LED that provides a local visual indication of the detector's status. The LED blinks every ten seconds as an indication that power is applied to the detector and lights continuously in alarm. These detectors also have the latching alarm feature. The alarm can be reset only by a momentary power interruption.

The detector also has provision for the connection of an optional Model RA400Z Remote Annunciator. The RA400Z provides a visual indication of an alarm and mounts to a single gang box.

**Spacing**

NFPA 72 defines the spacing requirements for smoke detectors. Typically, this is 30 feet when the detectors are installed on a smooth ceiling. However, ALL installations must comply with NFPA 72 and/or special requirements of the authority having jurisdiction.

**Figure 1. Surface mounting of Model 1400 detector on 3-1/2 and 4 inch octagonal box:**

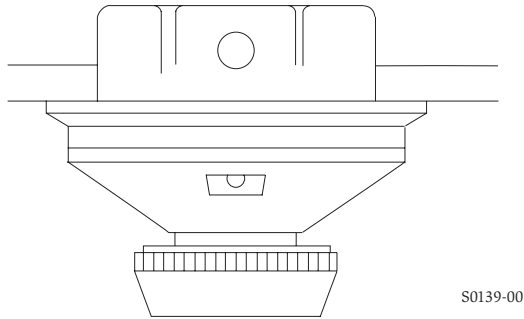

**Figure 2. Model 1400 detector mounting bracket:**

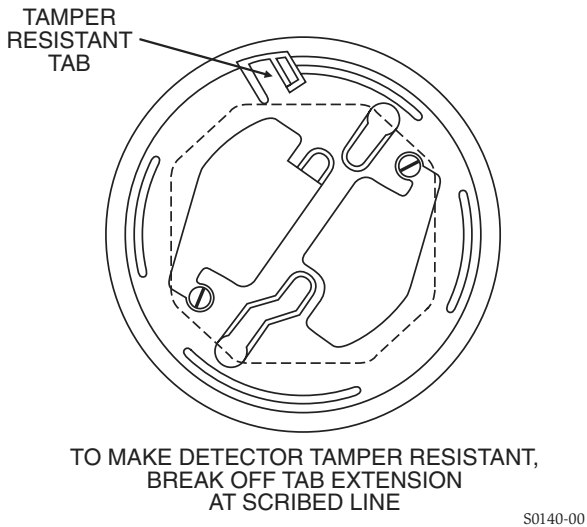

**Mounting**

Each 1400 detector is supplied with a mounting bracket kit that permits the detector to be mounted:

1. Directly to a 3½ inch or 4 inch octagonal, 1½ inch deep electrical box, or
2. To a 4 inch square electrical box by using a plaster ring with the supplied mounting bracket kit.

**Installation Wiring Guidelines**

All wiring must be installed in compliance with the National Electrical Code and all applicable local codes and any special requirements of the authority having jurisdiction, using the proper wire size. The conductors used to connect smoke detectors to control panels and accessory devices should be color-coded to reduce the likelihood of wiring errors. Improper connections can prevent a system from responding properly in the event of a fire.

For signal wiring (the wiring between interconnected detectors), it is recommended that the wire be no smaller than AWG 18. However, the screws and clamping plate can accommodate wire sizes up to AWG 12. The use of twisted pair wiring for the power (+ and -) loop is recommended to minimize the effects of electrical interference.

Smoke detectors and alarm system control panels have specifications for allowable loop resistance. Consult the control panel manufacturer’s specifications for the total loop resistance allowed for the control panel being used before wiring the detector loops.

Begin electrical connections by stripping about 3/8” insulation from the end of the wire. Then, slide the bare end of the wire under the clamping plate and tighten the clamping plate screw. A wiring diagram for a typical 2-wire detector system is shown in Figure 3.

**NOTE:** Break the wire at each terminal to ensure that the connections are supervised. Do NOT loop the wire under the terminals.

System Sensor smoke detectors are marked with a compatibility identifier located as the last digit of a five digit code stamped on the back of the product. Connect detectors only to compatible control units as indicated in System Sensor’s compatibility chart which contains a current list of UL-listed control units and detectors. A copy of this list is available from System Sensor upon request.

**Tamper-resistant Feature**

This detector includes a tamper-resistant feature that effectively prevents removal of the detector without the use of a tool. To make the detector tamper-resistant, break off the smaller tab at the scribed line on the tamper resistant tab, on the detector mounting bracket (see Figure 2), then install the detector. To remove the detector from the bracket once it has been made tamper resistant, use a small screwdriver to depress the tamper-resistant tab located in the slot on the mounting bracket and turn the detector counterclockwise for removal.

**Installation**



Disconnect the power to the alarm system control unit before installing detectors.

1. Wire the detector following the installation guidelines.
2. Line up arrows on the detector with the arrows on the mounting bracket.
3. Rotate the detector clockwise until it clicks into place.
4. After all detectors have been installed, apply power to the control unit.
5. Test the detector as described under TESTING.
6. Reset the detector at the system control panel.
7. Notify the proper authorities that the system is in operation.

**Figure 3. Wiring diagram for 1400 smoke detector used with two-wire control panel:**

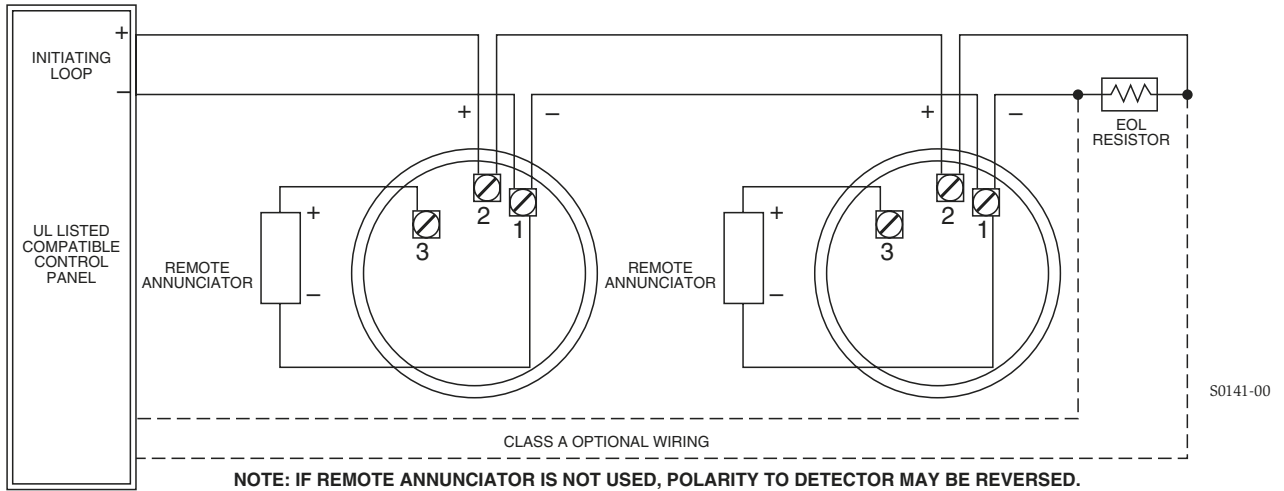

**CAUTION**

Dust covers can be used to help limit dust entry to the detector, but they are not a substitute for removing the detector during building construction. Remove any dust covers before placing system in service.

**CAUTION**

Smoke detectors are not to be used with detector guards unless the combination has been evaluated and found suitable for that purpose.

**Testing**

Before testing the detector, look for the presence of the flashing LED. If it does not flash, power has been lost to the detector (check the wiring), or it is defective (return for repair – refer to Warranty).

Detectors must be tested after installation and following periodic maintenance. Notify the proper authorities that the system is undergoing testing. The 1400 may be tested as follows:

- A. Recessed Test Switch
  1. A test switch is located on the detector housing (See Figure 4).
  2. Push and hold the recessed test switch with a 0.1 inch maximum diameter tool.
  3. The LED on the detector should light within 5 seconds.
- B. Test Module (System Sensor Model No. MOD400R)  
The MOD400R is used with an analog or digital voltmeter to check the detector sensitivity as described in the test module manual.
- C. Aerosol Generator (Gemini 501)  
Set the generator to represent 4%/ft. to 5%/ft. obscuration as described in the Gemini 501 manual. Using the bowl shaped applicator, apply aerosol until the unit alarms.

Notify the proper authorities that the system is back on line.

Detectors that fail these tests should be cleaned as described under MAINTENANCE and retested. If the detectors still fail these tests, they should be returned for repair.

**Figure 4. Bottom and side views showing position of test switch:**

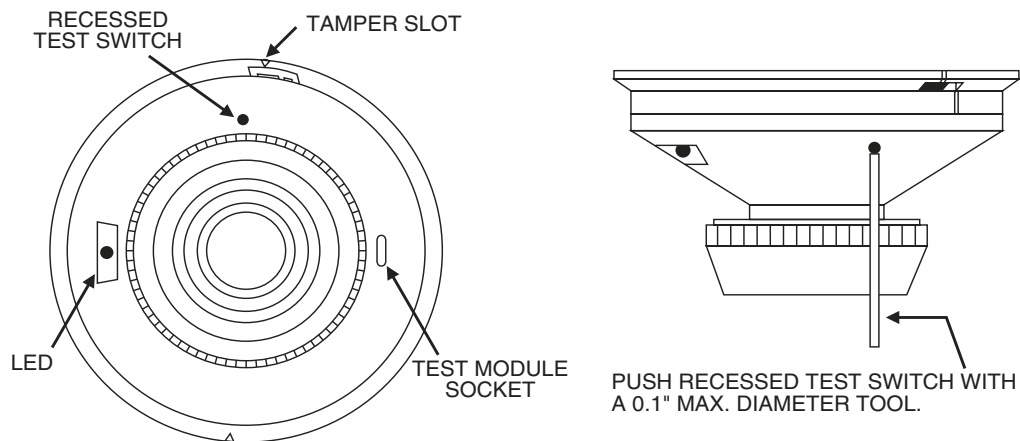

S0142-00

## Maintenance

**NOTE:** Before starting, notify the proper authorities that the smoke detector system is undergoing maintenance and, therefore, will be temporarily out of service. Disable the zone or system undergoing maintenance to prevent unwanted alarms.

The 1400 is cleaned as follows:

1. Remove the detector screen and cover assembly by depressing the three lock prongs on the top of the cover, rotating the cover clockwise, and pulling the screen cover assembly away from the detector (see Figure 5). Use of the System Sensor CRT400 cover removal tool is recommended.
2. Remove the screen from the cover.
3. Use a vacuum cleaner to remove dust from the screen, the cover, and the sensing chamber.
4. After cleaning, snap the screen into the cover, then place the cover and screen assembly on the detector turning clockwise until it is locked in place.
5. Test the detector as described in TESTING.
6. Notify the proper authorities that the system is back on line.

**Figure 5. Removal of cover and screen for cleaning:**

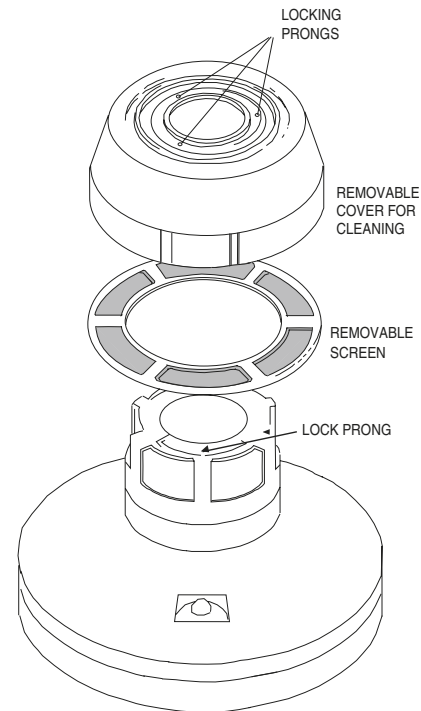

S0143-00

**Please refer to insert for the Limitations of Fire Alarm Systems**

### Three-Year Limited Warranty

System Sensor warrants its enclosed smoke detector to be free from defects in materials and workmanship under normal use and service for a period of three years from date of manufacture. System Sensor makes no other express warranty for this smoke detector. No agent, representative, dealer, or employee of the Company has the authority to increase or alter the obligations or limitations of this Warranty. The Company's obligation of this Warranty shall be limited to the repair or replacement of any part of the smoke detector which is found to be defective in materials or workmanship under normal use and service during the three year period commencing with the date of manufacture. After phoning System Sensor's toll free number 800-SENSOR2 (736-7672) for a Return Authorization number, send defective units postage prepaid to: System Sensor, Repair

Department, RA # \_\_\_\_\_, 3825 Ohio Avenue, St. Charles, IL 60174. Please include a note describing the malfunction and suspected cause of failure. The Company shall not be obligated to repair or replace units which are found to be defective because of damage, unreasonable use, modifications, or alterations occurring after the date of manufacture. In no case shall the Company be liable for any consequential or incidental damages for breach of this or any other Warranty, expressed or implied whatsoever, even if the loss or damage is caused by the Company's negligence or fault. Some states do not allow the exclusion or limitation of incidental or consequential damages, so the above limitation or exclusion may not apply to you. This Warranty gives you specific legal rights, and you may also have other rights which vary from state to state.