

OPERATOR'S MANUAL 42" SNOW PLOW/ DOZER BLADE

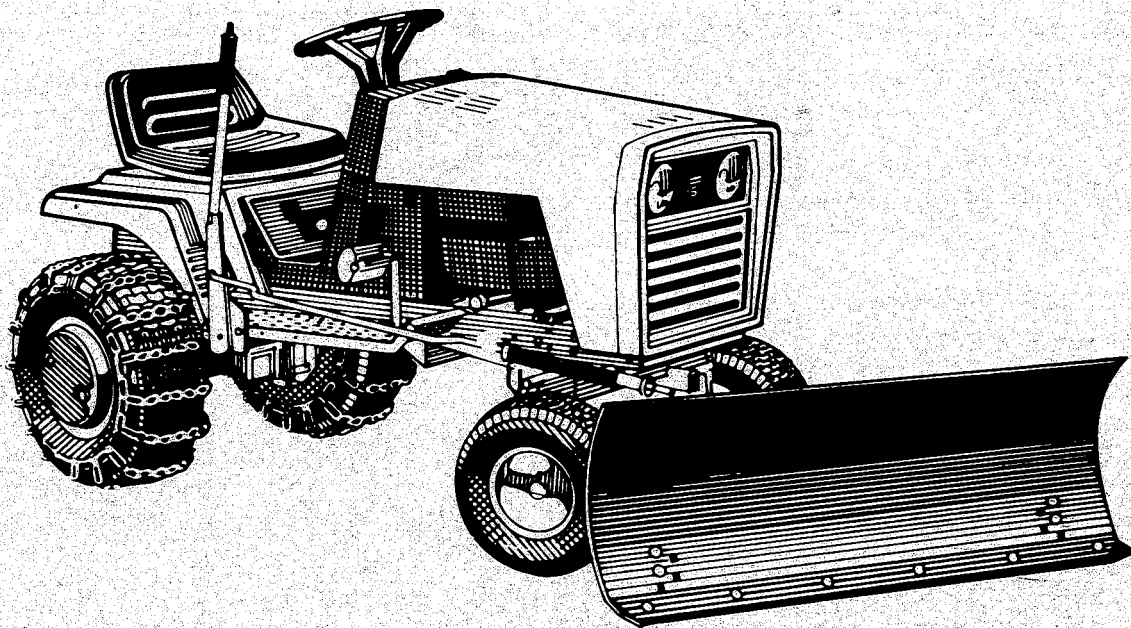

ORM - 1701943
PRINTED IN U.S.A.

42" SNOW PLOW/DOZER BLADE
MFG. NO. 1691520

HITCH ASSEMBLY
MFG. NO. 1691523

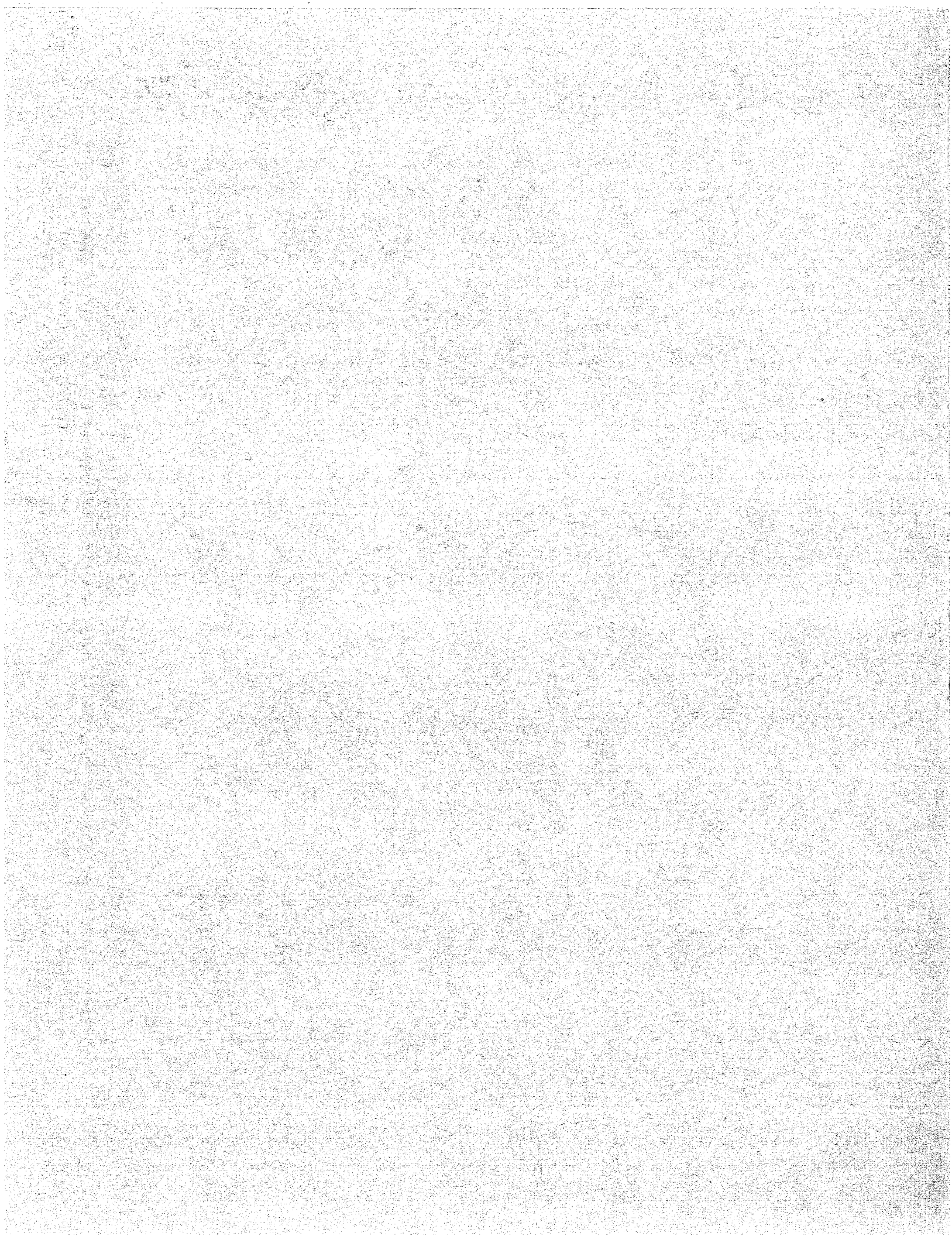

Contents

SAFETY RULES	2
ASSEMBLY, INSTALLATION & REMOVAL	4
OPERATION AND NORMAL CARE	5
ADJUSTMENTS	6

Safety Rules



Read these safety rules and follow them closely. Failure to obey these rules could result in loss of control of vehicle, severe personal injury to yourself or bystanders, or damage to property or equipment. The triangle  in the text signifies important cautions or warnings which must be followed.



ALL WARNING, CAUTION, and instructional messages on this attachment and on your tractor should be carefully read and obeyed. Personal bodily injury can result when these instructions are not followed.

GENERAL

- Read the operator's manual carefully. Be thoroughly familiar with the controls and proper use of the equipment. Know how to stop the unit and disengage the controls quickly.
- Never allow children to operate the machine. Do not allow adults to operate it without proper instruction.
- Keep the area of operation clear of all persons, particularly small children, and pets.
- Do not carry passengers.
- Make sure:
 - a. tractor and attachments are in good operating condition.
 - b. all safety devices and shields are in place
 - c. and in good working condition, and
 - d. all adjustments (skid shoe height, etc.) have been made.

PREPARATION

- Handle gasoline with care — it is highly flammable.
 - a. Use approved gasoline container.
 - b. Never remove the cap of the fuel tank or add gasoline to a running or hot engine, or fill the fuel tank indoors. Wipe up spilled gasoline.

- Do not run the engine indoors. Exhaust fumes are dangerous.
- Shift into neutral before attempting to start the engine.
- Wear heavy footwear. Do not operate tractor when barefoot or when wearing open sandals or canvas shoes.

OPERATION

- Do not allow anyone to use the snow plow/dozer blade unless they have been instructed on how to operate it safely.
- Never attempt to adjust, repair or service the snow plow/dozer blade while the tractor engine is running.
- Do not allow others near the snow plow/dozer blade while it is being used.
- Use the snow plow/dozer blade only in daylight, or good artificial light.
- Always lower the snow plow/dozer blade completely to the ground when leaving it unattended to prevent it from being accidentally lowered and causing injury. On spring assisted units, make sure blade is locked in "DOWN" position.
- Always operate the tractor at reasonable speeds to prevent the blade from catching an object and stopping the tractor abruptly.

Assembly, Installation & Removal

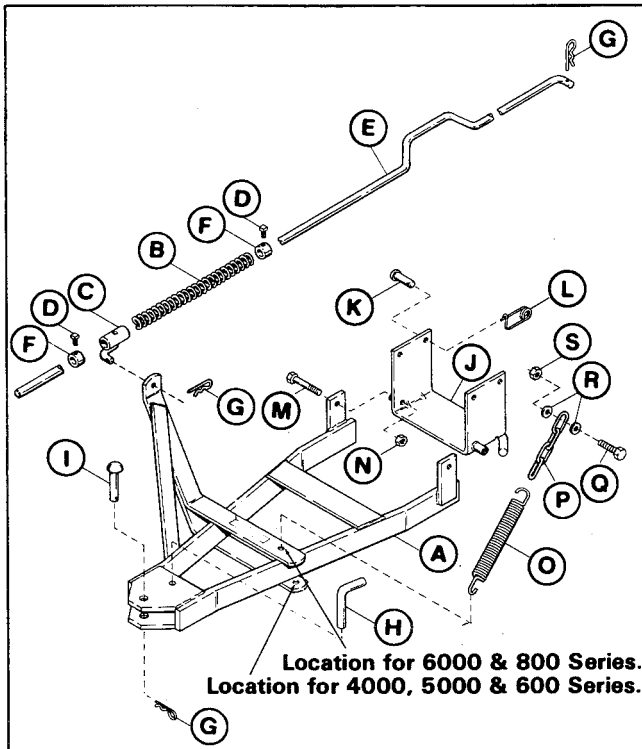

Figure 1. Push Bar and Lift Rod

Ref. No.	Qty.	Description
A	1	Bar Assy., Push
B	1	Spring
C	1	Guide Assy., Rod
D	2	Setscrew, 5/16-18 x 1/2
E	1	Rod, Lift
F	2	Collar, Set
G	3	Spring, Clip
H	1	Pin, Pivot
I	1	Pin, King
J	1	Bracket Assy.
K	4	Pin
L	4	Clip, Pin
M	2	Capscrew, 3/8-16 x 2-1/4
N	2	Lockwasher, 3/8-16
O	1	Spring
P	1	Chain, 4-Link
Q	1	Capscrew, 5/16-18 x 1-1/4
R	2	Washer, Plain, 5/16
S	1	Nut, Hex Lock, 5/16-18

ASSEMBLY

1. Place the blade on a flat surface.
2. Insert eyebolt (A, figure 2) thru lug on blade and screw on 5/16 nut (B) only far enough so that it is flush with the end of the eyebolt.
3. Hook the spring (C) into the pivot frame (D). Stretch the spring with a pliers to hook springs on eyebolt (A).

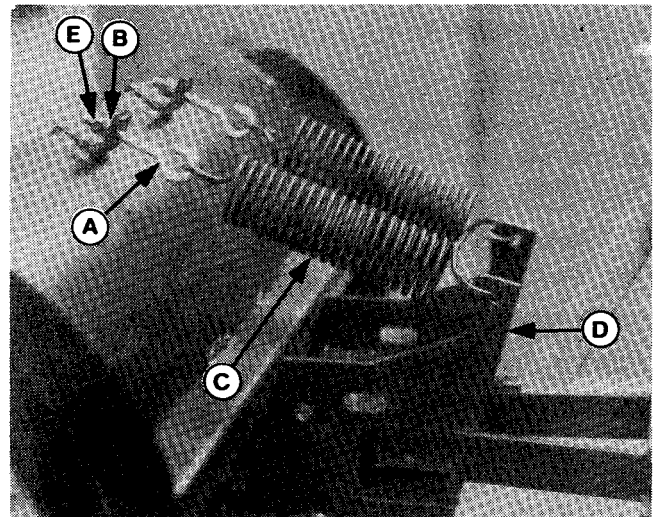

Figure 2. Tension Springs

- A. Eyebolt
- B. Nut, 5/16
- C. Spring
- D. Pivot Frame
- E. Nut, 5/16

4. Repeat steps 2 and 3 for the other spring.
5. Tighten the nut (B) on both eyebolts down to expose about 3/4 inch (19 mm) of thread. (See page 6 for spring tension adjustment.)
6. Add the other nut (E) to each eyebolt. Hold the first nut (B) secure with a wrench and tighten the second nut (E) securely on each eyebolt.
7. Assemble the chain (A, figure 3) to the tractor as follows.
 - a. On left-hand side, remove the upper self-tapping screw that holds bumper to frame. This is the hole used for installing chain in the following steps, using one 5/16-18 x 1-1/4 capscrew (B), two 5/16 washers, and one 5/16 locknut.

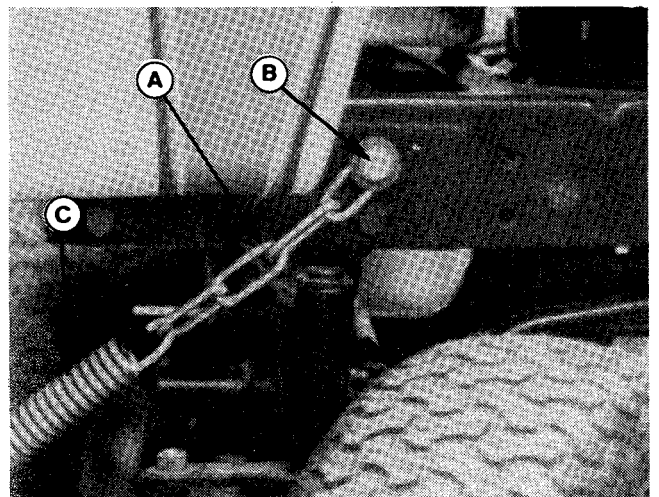

Figure 3. Chain

- A. Chain
- B. Capscrew
- C. Spring

- b. Place one 5/16 washer onto the capscrew. Then place the chain on the capscrew, and then the other 5/16 washer.
- c. Insert the capscrew (B, figure 3) as shown. From inside frame, install 5/16 locknut onto capscrew. Tighten snug only at this time. The spring (C) will be installed in "Installation" section, and hardware will be tightened.

INSTALLATION

1. Drive the tractor over the push bar until rear of push bar is under front hitch.
2. Stop engine, remove key and set parking brake.
3. Attach the bracket (J, figure 4) to the two rear holes in the tractor hitch with the four pins (F) and safety clips (G) provided. Insert the pins from the outside. Make sure the push bar mounting holes (in the bracket) are toward the front.
4. Attach the push bar to the bracket, using the two 3/8-16 x 2-1/4 capscrews (H) and 3/8 locknuts (I) provided.

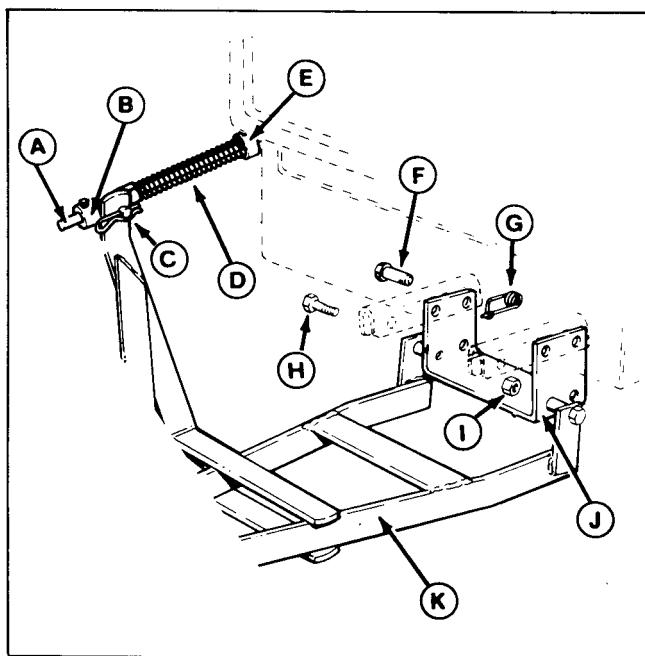

Figure 4. Hitch & Lift Rod

- | | |
|---------------------|-----------------------------|
| A. Lift Rod | G. Safety Clip |
| B. Front Set Collar | H. Capscrew, 3/8-16 x 2-1/4 |
| C. Spring Clip | I. Locknut, 3/8-16 |
| D. Spring | J. Bracket |
| E. Rear Set Collar | K. Push Bar |
| F. Pin | |

5. Raise the push bar and hook up the spring (A, figure 5). Figure 5 shows spring location (B) for lawn tractors (4000, 5000 or 600 series). For garden tractor, 6000 Series or 800 Series, use location "C".
6. Lower the push bar and tighten the capscrew and nut which hold chain to tractor frame.
7. Insert front of push bar (A, figure 6) into pivot frame on rear of blade. Then install king pin (I, figure 1) down thru holes in hitch and pivot frame. Secure king pin (I) with spring clip (G).

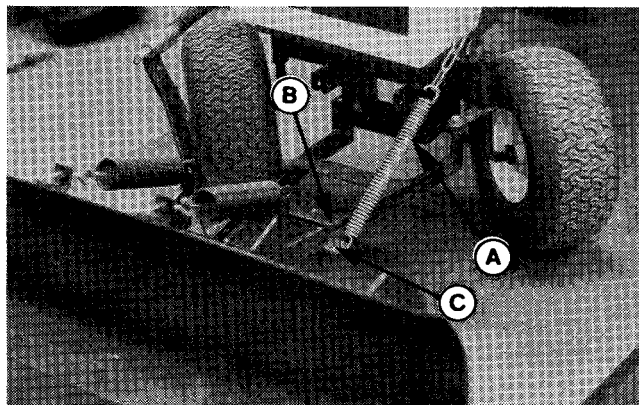

Figure 5. Lift-Assist Spring

- A. Spring
- B. Location for 4000, 5000, 600 Series Tractors.
- C. Location for 6000 or 800 Series Tractors

8. Using king pin as the pivot, swivel push bar to align holes for pivot pin (B, figure 6). Then install pivot pin downward through holes in blade and push bar. The pivot pin can be installed in any of three holes, depending on desired blade angle.

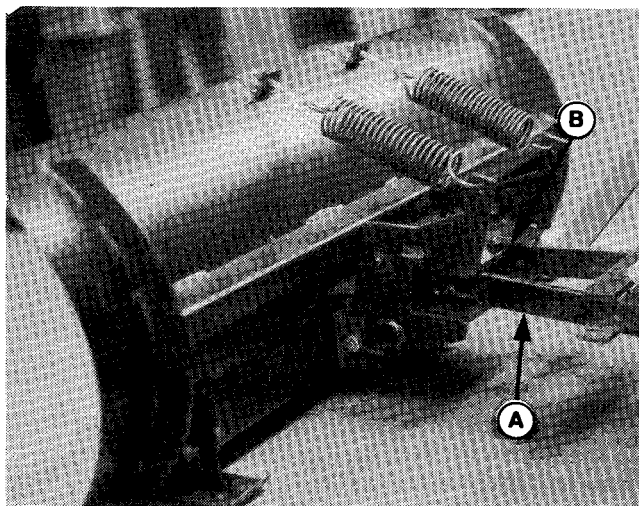

Figure 6. Dozer Blade Assembled and Installed

- A. Push Bar
- B. Pivot Pin

9. Assemble lift rod per figure 1. Insert prong of rod guide (C, figure 1) through hole in upright of push bar (A), and secure with spring clip (G).
10. Connect rear of lift rod (E, figure 1) to lift lever mounted on tractor using the spring clip (G).
11. Perform Lift Rod Adjustment, See page 6.

REMOVAL

1. Lower the blade.
2. Remove blade and lift rod from push bar.
3. Raise push bar and unhook the spring (A, figure 5) from the chain.
4. Disconnect the lift rod from the lift lever on tractor by removing the spring clip.
5. Remove the bracket (J, figure 4) from the tractor hitch by removing four pins and safety clips.
6. Reinstall all pins (king pin, pivot pin, clevis pins) and secure with spring or safety clip for storage.

Operation and Normal Care

TRANSPORTING

For maximum ground clearance, transport the blade to and from work areas fully raised and angled straight ahead.



WARNING

Be particularly careful and operate at low tractor speeds in any area where the blade can hook on solid objects. Such objects can cause the tractor to be jarred or come to an abrupt stop.

DOZING & SNOW PLOWING

When dozing, push the dirt to the desired location, then drag the blade backwards for final leveling. Pack down the dirt or gravel by driving the tractor over the leveled area.

Use any grade to your advantage. Plow downhill and set the blade angle so that plowed material (especially snow) is moving downhill as it leaves the blade. To change blade angle, pull out the pivot pin (B, figure 6). Pivot the blade to one of the other three holes and re-install the pivot pin.

For large drifts of snow, bite off small amounts instead of plowing a full blade width.

Set tractor speed to obtain the needed power to move the material. Operate at a safe speed, depending on conditions, so that you have complete control of the tractor. Rear wheel weights and chains are recommended for slippery surfaces.

OPERATION ON SLOPES

Never operate on slopes greater than 30 percent (16.7°) which is a rise of three feet (91 cm) in ten feet (305 cm) forward. Use two rear wheel weights (one per wheel) when operating on slopes greater than 20 percent (11.3°).

Always operate up and down the face of slopes, and never across the face. Use a slow ground speed on slopes.

NORMAL CARE

After dozing jobs, hose down the blade to remove excess dirt. Coat bare metal surfaces to prevent rusting. Lightly oil all pivot points.

If the wear plate on bottom of the blade is worn excessively, replace it with a new one by removing the six carriage bolts.

Adjustments

LIFT ROD

For initial setting, place front set collar (B, figure 4) one inch from rod guide with blade fully lowered. Place rear set collar (E) against spring (D). Tighten the setscrews in the two set collars. To adjust, perform the following.

1. Fully raise the blade by pulling back on the tractor lift lever. Measure distance between scraper bar and ground. If it measures approximately six inches, it is properly adjusted. If not, proceed to step 2.
2. Lower the blade. Loosen the setscrew in the front set collar. Move the set collar back to increase clearance or forward to decrease clearance. Tighten the setscrew. Recheck the measurement.

NOTE

Different ground contours may require different adjustments. Moving the rear set collar toward rear will allow the blade to follow a rolling contour. Lower the blade to adjust the rear set collar. The farther back the rear set collar is positioned, the more the blade will float. Moving the rear set collar toward the front will increase down pressure.

SHOE ADJUSTMENT

Alternate holes are provided to permit adjustment of the shoe assemblies for raising and lowering the blade to various working heights (see figure 7). When cleaning snow from gravel or earth drives or walks the shoe assemblies should be lowered fully to prevent blade contact with gravel or ground. When cleaning smooth hard surfaces, like concrete, the shoe assemblies are normally placed fully up to allow the blade to scrape the surface.

To adjust the skid, raise the blade off the ground and block with a piece of wood. Loosen the bolts (B, figure 7) and move the skid shoes (A) up or down to desired height. Tighten the bolts securely.

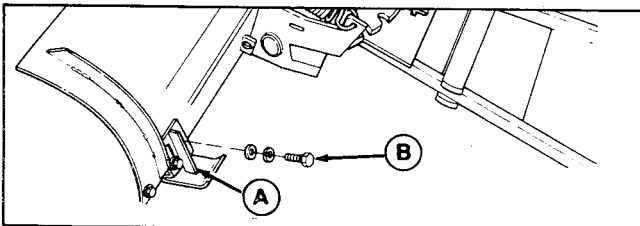

Figure 7. Skid Shoes

- A. Skid Shoes
- B. Bolts

SPRING TENSION

This snow plow/dozer blade is spring loaded so that when the blade strikes a solid object, the springs will allow the blade to release as shown in figure 8 rather than cause damage. The blade will go back to original position after object is cleared.

To adjust spring tension, hold rear nut (B, figure 2) and loosen front nut (E). Tighten rear nut (B) to increase spring tension or loosen to decrease. Tighten front nut (E) so the two nuts are drawn firmly together.

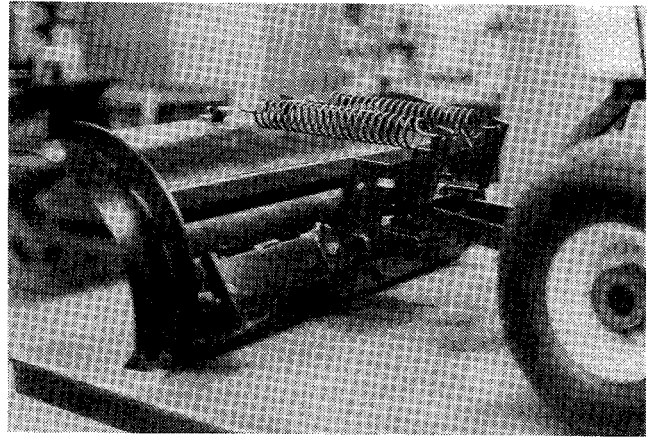

Figure 8. Dozer Blade "Released"

