

Roofing and Medium-Duty Stapler SPS

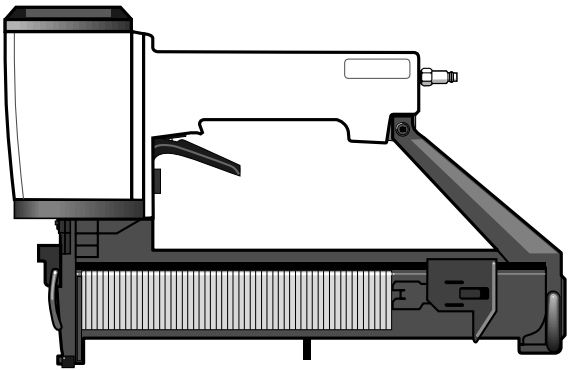

This oil-less wide-crown stapler is popular for composite shingle roofing application, general woodworking, and industrial fastening needs.

SENCO's SPS is available in three models for a wide variety of roofing and general industrial applications. They drive 16-gauge 1" wide-crown staples in lengths from 3/4" to 1 1/2".

Applications:

The SPS Roofing Stapler is widely used in composite shingle roofing and reroofing applications as well as roofing felt installation.

The two general industrial models are used for lath wire attachment, insulation attachment, furniture and cabinet assembly, and carton-to-skid attachment in packaging.

Features:

- Easy Load/E-Z Clear System
- Drives 1 1/2" length wide-crown staples into hardwoods and through roofing shingles
- Oil-free, no lubrication required
- Only two moving O-rings
- Quiet operation
- Mode of operation – either bottom fire/trigger fire or trigger fire
- Special wear plate and hardened safety on roofer model resists granule abrasion
- 35% more power
- Ergonomically designed handle
- Die-cast housing, one-piece piston driver assembly and rolling diaphragm increases life, cuts downtime



Roofing and Medium-Duty Stapler SPS

Tool Specifications:

Tool Weight: 5.3 lbs.
Height: 9 7/8"
Length: 13 1/2"
Width: Main Body 3 1/32"
Staple Capacity: 140+
Mode of Operation: either bottom fire/trigger fire tools or trigger fire tools are available*
Operating Pressure Range: 70-120 p.s.i.g.

Tool	Model	Fastener Range
1 1/2" Roofer	340005N	P12-P17
1 1/4" Industrial	340002N	P11-P15
1 1/2" Industrial	340004N	P12-P17

Any of the SPS models above can be adapted to drive 1/2" through 3/4" P staples by ordering and installing P/N FAO 155. A modified magazine assembly is required to drive 1 3/4" and 2" staples.

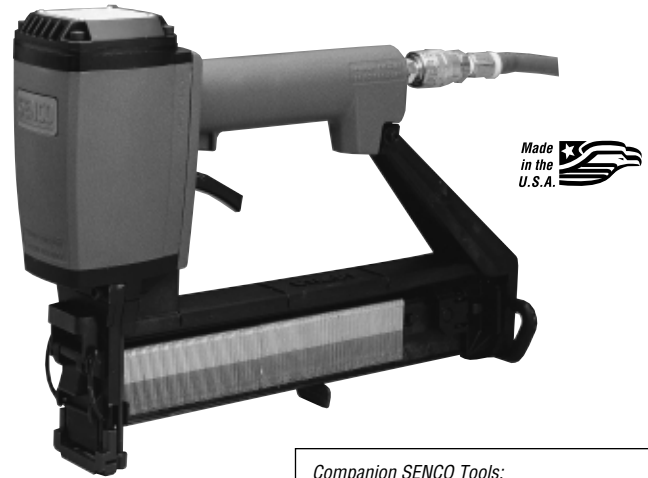

Companion Senco Tools:
 The PW drives P08, P10, P11, P12, P13, and P15.
 The MW drives P11, P12, P13, P15, P17, and P19
 (with modified magazine).

Tool Specifications:

Fastener Specifications:
P Series Staples
 • Crown: 1" (25mm)
 • Wire Size: 16 Gauge (1.6 mm)

Lengths	Inches	3/4"	7/8"	1"	1 1/4"	1 1/2"
	Millimeters	19	22	25	32	38
Part No.	P11BAB	P12BAB	P13BAB	P15BAB	P17BAB	
Staples/Box	10/M	10/M	10/M	10/M	10/M	
Boxes/Carton	1	1	1	1	1	

NOTE: All part numbers shown are for galvanized carbon steel staples with chisel point and SencotePlus®.

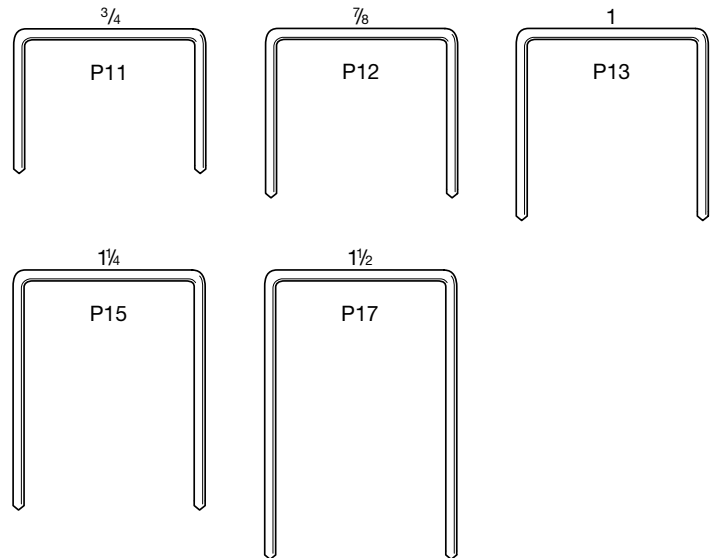

* "Restrictive Trigger" activated tools are used for applications where precision nail or staple placement is desired. You must first depress the safety element where you want to drive a nail or staple and then pull the trigger. After each nail or staple is driven, completely release the trigger and lift the tool off the work surface.

"Dual Action" activated tools are used for applications where high-production work is desired. There are two modes of operation:

Bottom Fire Method: This method of operation is sometimes called bounce

firing. You must keep the trigger pulled while moving the tool along the work surface with a bouncing motion, depressing the safety element where you want to drive a nail or staple.

Trigger Fire Method: First depress the safety element where you want to drive a nail or staple and then pull the trigger.

For instructions on safe use of tools with either of these activating mechanisms, please refer to the Operating Instructions or Customer Satisfaction and Safety Reminder contained in your tool carton.

For additional information on how Senco fastening systems will save you time, reduce costs, and increase quality, call your nearest Authorized Senco Dealer or Distributor listed in the Yellow Pages under "Staples," or call our toll-free Action Line: 1-800-543-4596.