

PARABODY

Serious Steel

874106 MULTI-ANGLE BENCH

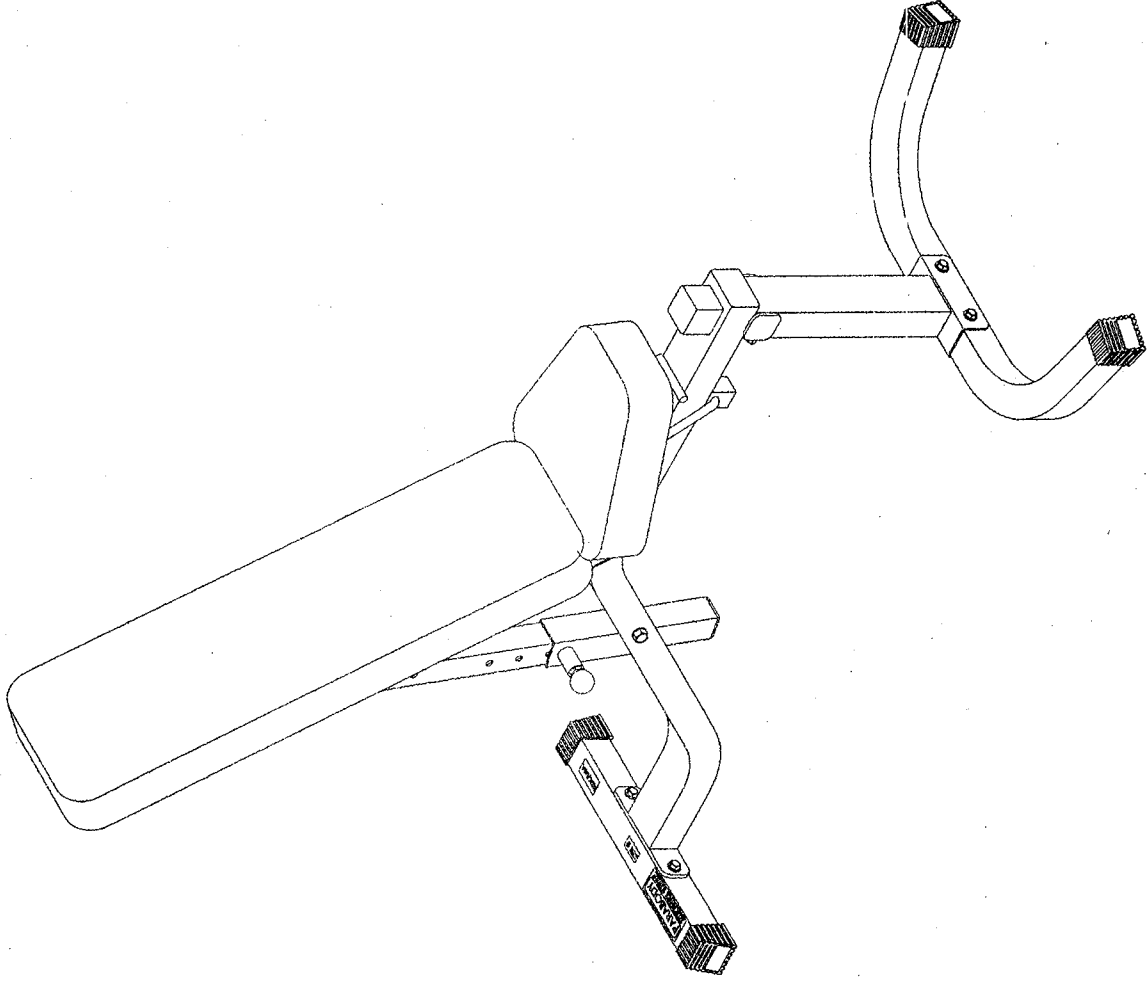

ASSEMBLY INSTRUCTIONS

IMPORTANT NOTES

WELCOME TO THE WORLD OF Serious steel!

Please note:

* Thank you for purchasing the Parabody 874101 MULTI-ANGLE BENCH. Please read these instructions thoroughly and keep them for future reference. This product must be assembled on a flat, level surface to assure its proper function.

We recommend cleaning your product (pads and frame) on a regular basis, using warm soapy water. Touch-up paint can be purchased from your Parabody customer service representative at (800) 328-9714.

There is a risk assumed by individuals who use this type of equipment. To minimize risk, please follow these rules:

1. Inspect equipment daily. Tighten all loose connections and replace worn parts immediately. Failure to do so may result in serious injury.
2. Do not allow minors or children to play on or around this equipment.
3. Exercise with care to avoid injury.
4. If unsure of proper use of equipment, call your local Parabody distributor or call the Parabody customer service department at (800) 328-9714.
5. Consult a physician before beginning any exercise program.

Tools Required for Assembly

- * 3/4" wrench
- * 9/16" wrench
- * Ratchet with 3/4" and 9/16" sockets
- * Adjustable wrench
- * Tape measure

Bolt Length Ruler

NOTE: BOLT LENGTH IS MEASURED FROM THE UNDERSIDE OF THE HEAD OF THE BOLT.

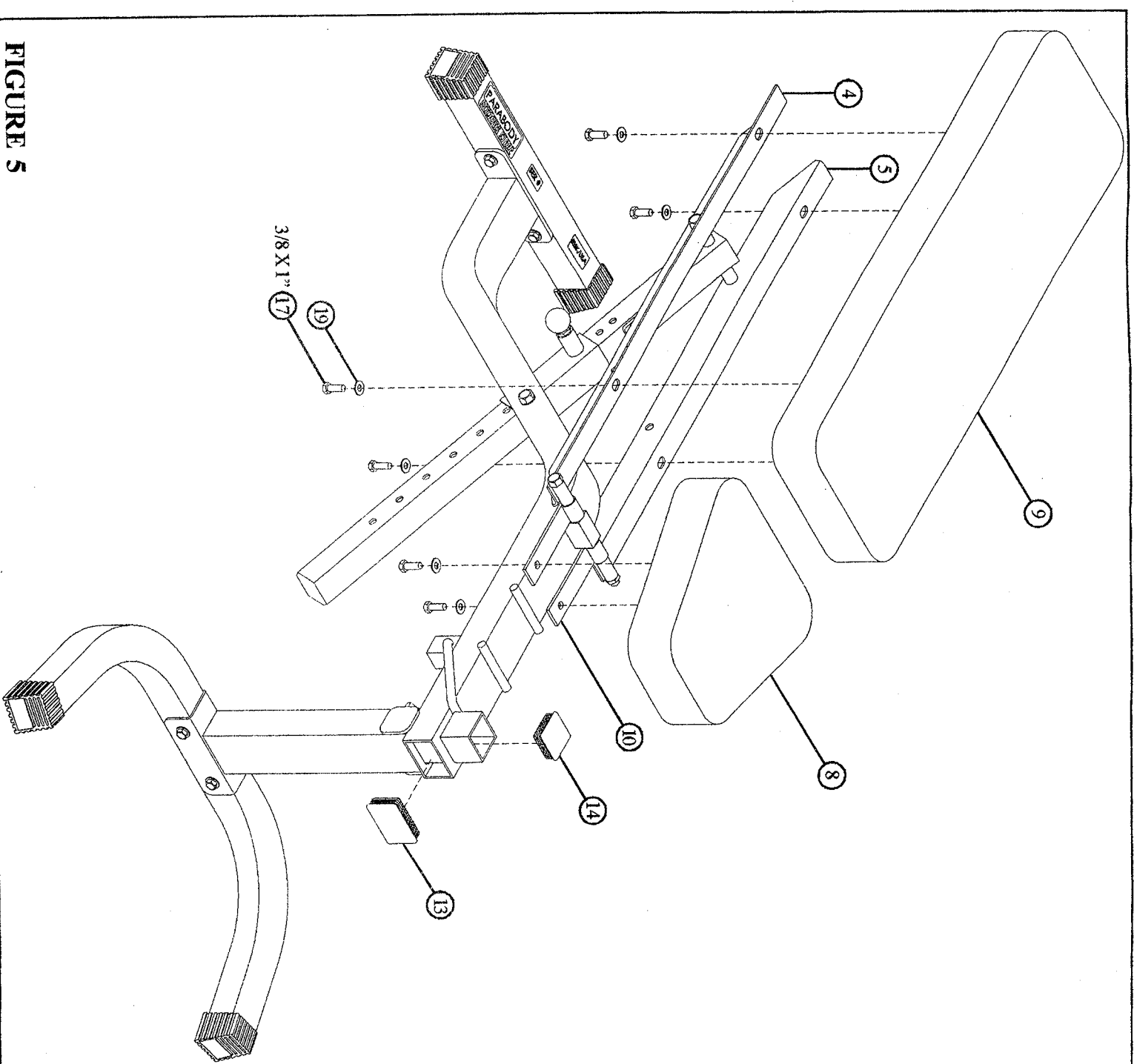
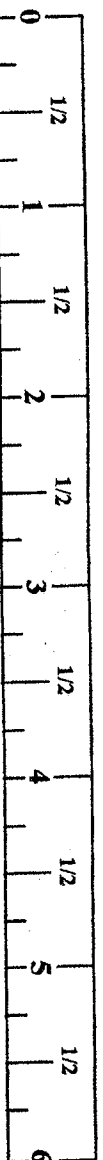
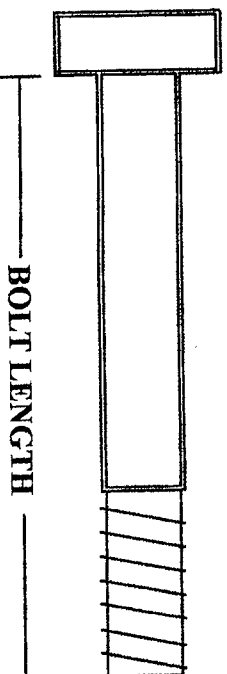

FIGURE 5

STEP 5:

- **SECURELY** assemble the SEAT PAD (8) to the HINGE TABS (10) using two 3/8 X 1" BOLTS (17) and two 3/8" WASHERS (19) as shown in FIGURE 5.
- **SECURELY** assemble the BACK PAD (9) to the LEFT BACK PAD ANGLE (4) and the RIGHT BACK PAD ANGLE (5) using four 3/8 X 1" BOLTS (17) and four 3/8" WASHERS (19) as shown in FIGURE 5.
- Slide one 2" SQ. END CAP (14) into the top of the BENCH FRAME (1) as shown in FIGURE 5.
- Slide one 3 X 2" END CAP (13) into the front of the BENCH FRAME (1) as shown in FIGURE 5.

Thank you for purchasing the Parabody 874101 MULTI-ANGLE BENCH. If unsure of proper use of equipment, call your local Parabody distributor or call the Parabody customer service department at (800) 328-9714.

PARTS LIST

| KEY | PART # | DESCRIPTION | QTY | KEY | PART # | DESCRIPTION | QTY |
|-----|---------|----------------------|-----|-----|---------|----------------------------|-----|
| 1 | 6650603 | BENCHFRAME | 1 | 16 | 6145801 | THUMBSCREW | 1 |
| 2 | 6650103 | ADJUSTABLE SLIDE | 1 | 17 | 3102909 | 3/8 X 1" BOLT | 6 |
| 3 | 6649303 | ADJUSTABLE SLEEVE | 1 | 18 | 3102904 | 3/8 X 3" BOLT | 4 |
| 4 | 6624202 | LEFT BACK PAD ANGLE | 1 | 19 | 3102501 | 3/8" WASHER | 14 |
| 5 | 6624302 | RIGHT BACK PAD ANGLE | 1 | 20 | 3102802 | 3/8" LOCK NUT | 4 |
| 6 | 6259103 | FRONT BASE | 1 | 21 | 3102960 | 1/2 X 3-3/4" BOLT | 1 |
| 7 | 6575003 | REAR BASE | 1 | 22 | 3102949 | 1/2 X 5-1/2" BOLT | 1 |
| 8 | 6654502 | SEAT PAD | 1 | 23 | 3202104 | 1/2 X 8" BOLT | 1 |
| 9 | 6654402 | BACK PAD | 1 | 24 | 3102804 | 1/2" LOW HEIGHT LOCK NUT | 3 |
| 10 | 6406401 | HINGE TAB | 2 | 25 | 3109602 | 1/2" PAL NUT | 1 |
| 11 | 6412001 | SPRING PIN ASSEMBLY | 1 | 26 | 6417801 | 1/2 X 1" SPRING | 1 |
| 12 | 6236701 | 1-3/4" SQ. END CAP | 1 | 27 | 6650201 | 1/2" FLANGE SPACER | 2 |
| 13 | 6692601 | 3 X 2" END CAP | 1 | 28 | 6416601 | 1-1/2 X 3/4" GLIDE (8 PER) | 1 |
| 14 | 6405201 | 2" SQ. END CAP | 1 | 29 | 6406501 | 1/2" DIA U-PIN | 1 |
| 15 | 6467001 | 2" SQ. COVER CAP | 4 | | | | |

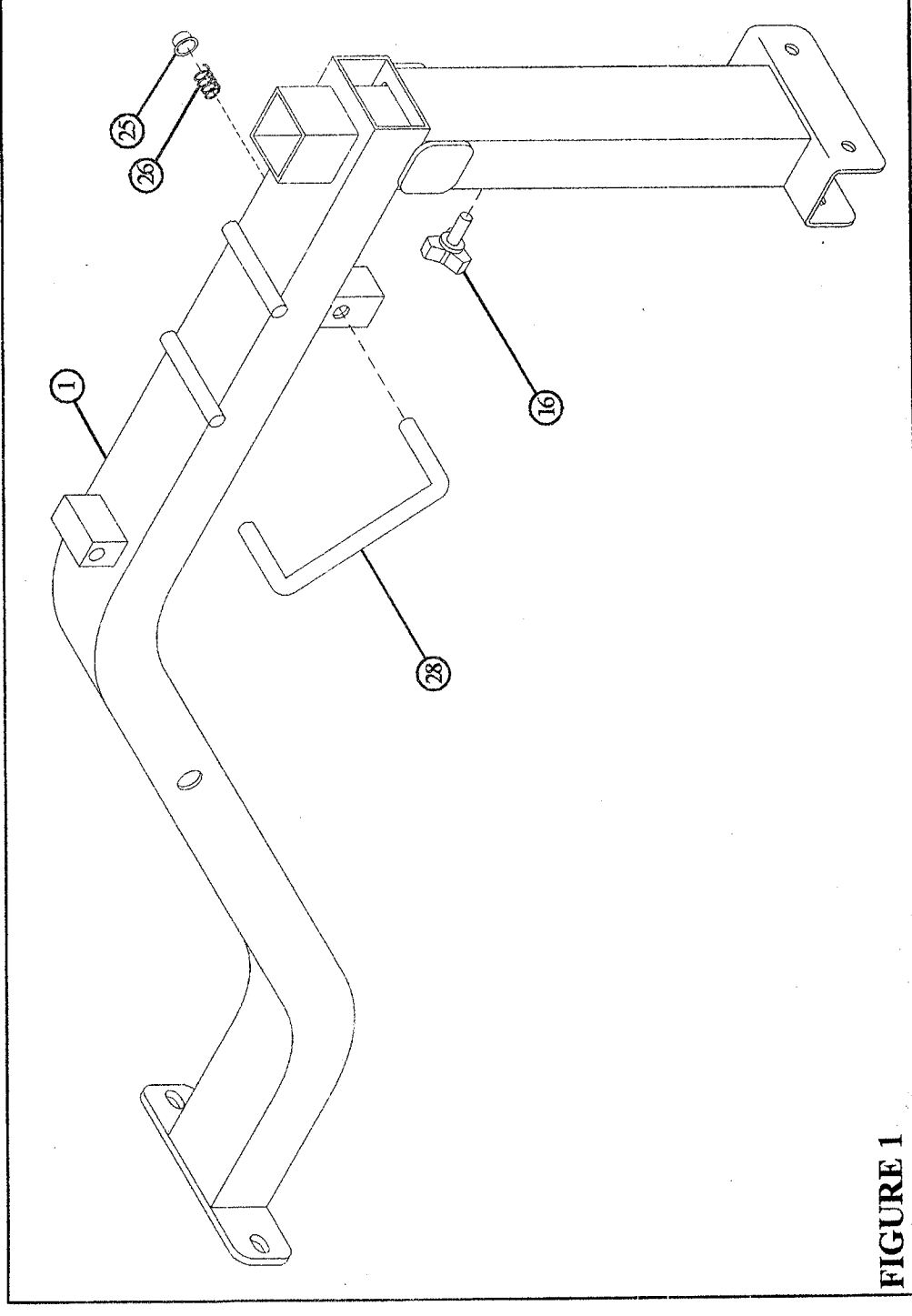

FIGURE 1

STEP 1:

- Assemble the 1/2" DIA. U-PIN (29) to the BENCHFRAME (1) using one 1/2 X 1" SPRING (26), and one 1/2" PAL NUT (25) as shown in FIGURE 1.
- Thread one THUMBSCREW (16) into the BENCH FRAME (1) as shown in FIGURE 1. The THUMBSCREW (16) will be used to tighten down attachments.

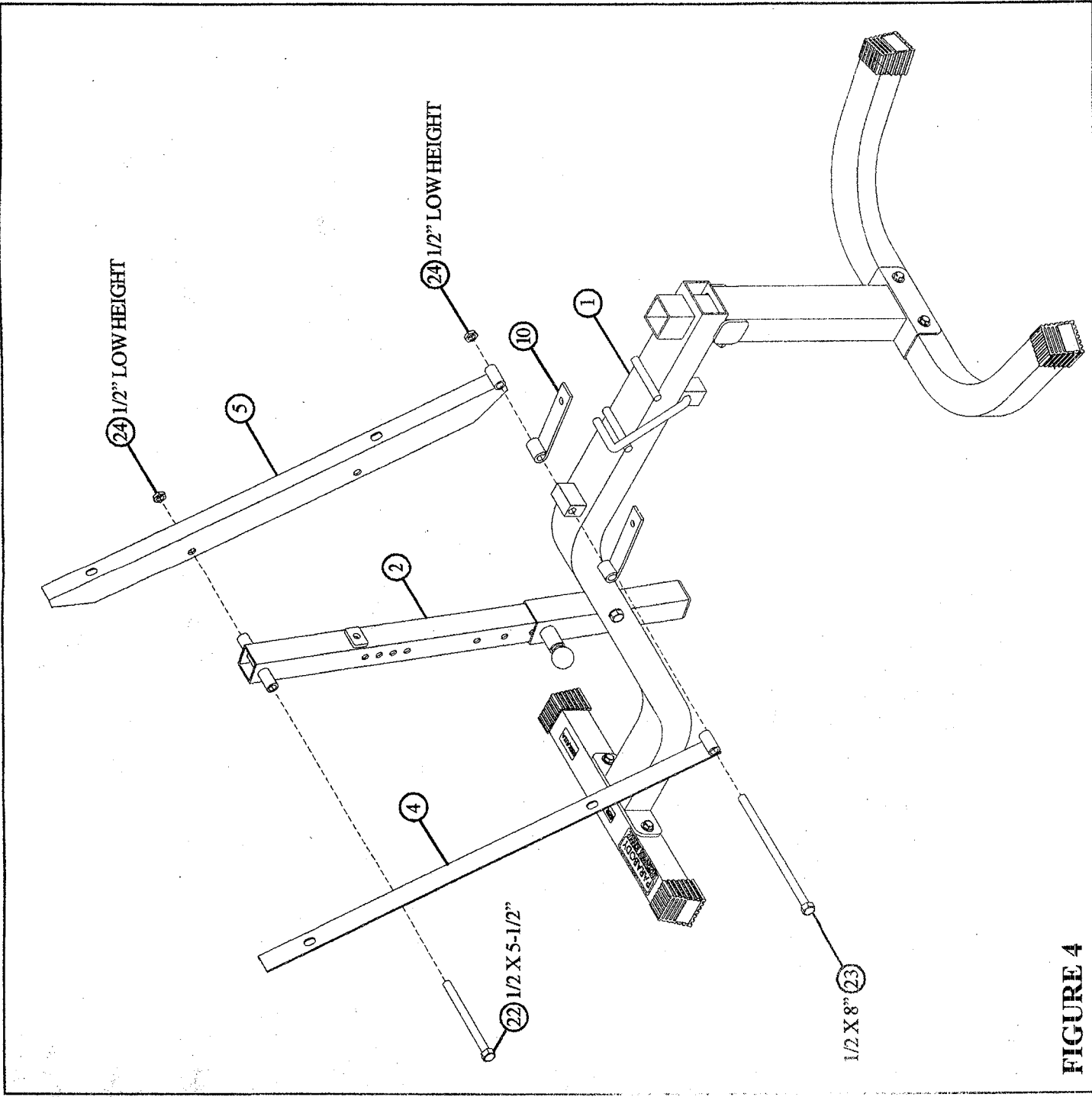
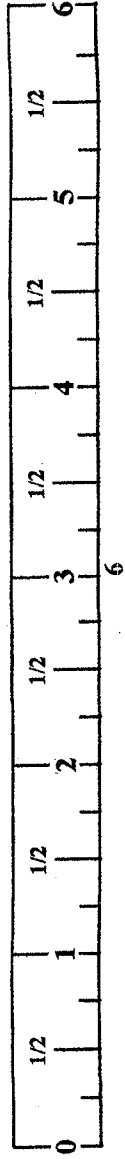

FIGURE 4

STEP 4:

- Assemble the LEFT and RIGHT BACK PAD ANGLE (4 & 5) and two HINGE TABS (10) to the BENCHFRAME (1) using one 1/2 X 8" BOLT (23) and one 1/2" LOW HEIGHT LOCK NUT (24) as shown in FIGURE 4.
- Assemble the LEFT and RIGHT BACK PAD ANGLE (4 & 5) to the ADJUSTABLE SLIDE (2) using one 1/2 X 5-1/2" BOLT (22) and one 1/2" LOW HEIGHT LOCK NUT (24) as shown in FIGURE 4.



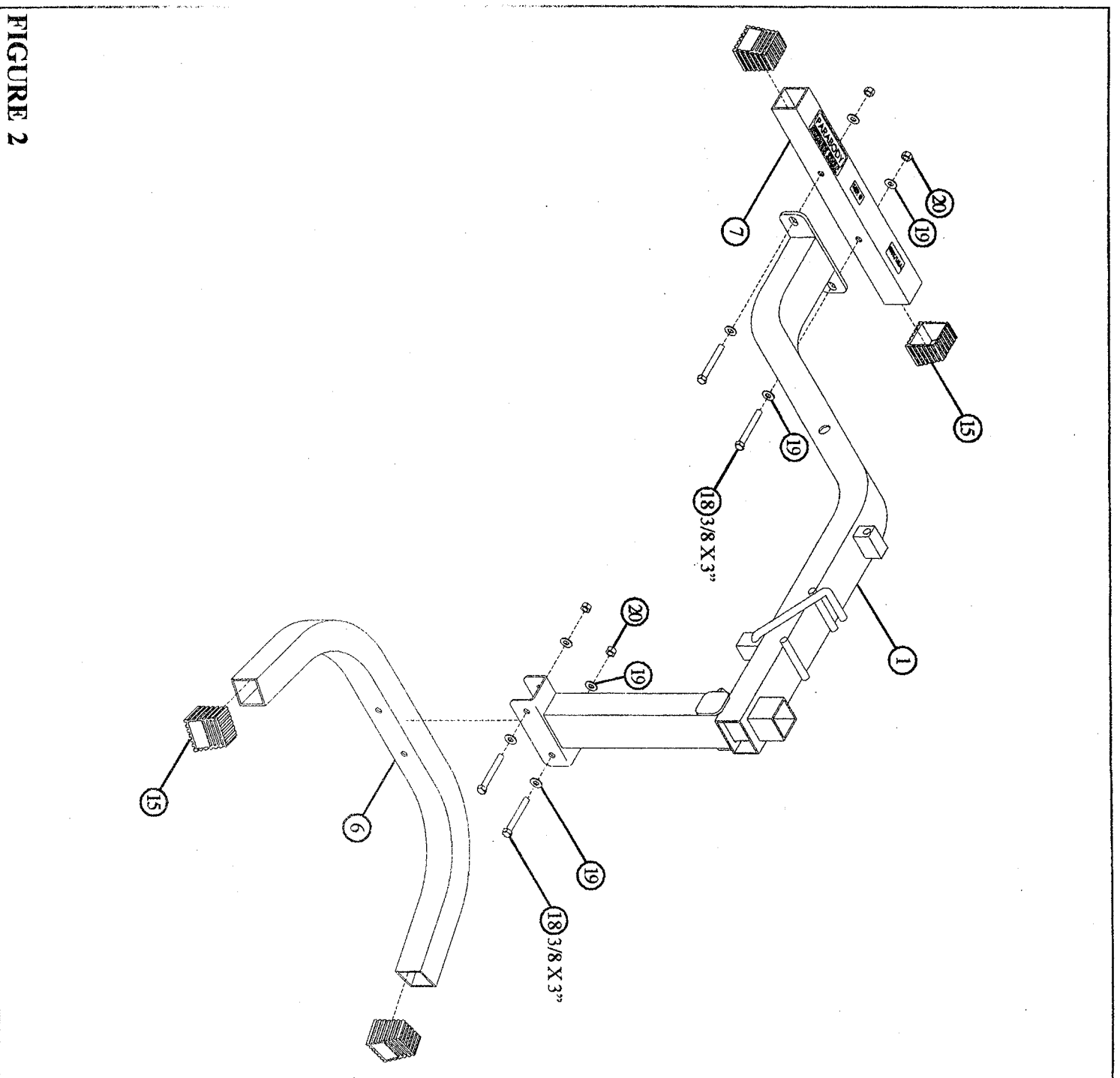

FIGURE 2

STEP 2:

- Slide four 2" SQ. COVER CAPS (15) over the ends of the FRONT & REAR BASE (6 & 7) as shown in FIGURE 2.
- SECURELY assemble the FRONT BASE (6) to the BENCH FRAME (1) using two 3/8 X 3" BOLTS (18), four 3/8" WASHERS (19), and two 3/8" LOCK NUTS (20). See FIGURE 2.
- SECURELY assemble the REAR BASE (7) to the BENCH FRAME (1) using two 3/8 X 3" BOLTS (18), four 3/8" WASHERS (19), and two 3/8" LOCK NUTS (20). See FIGURE 2.

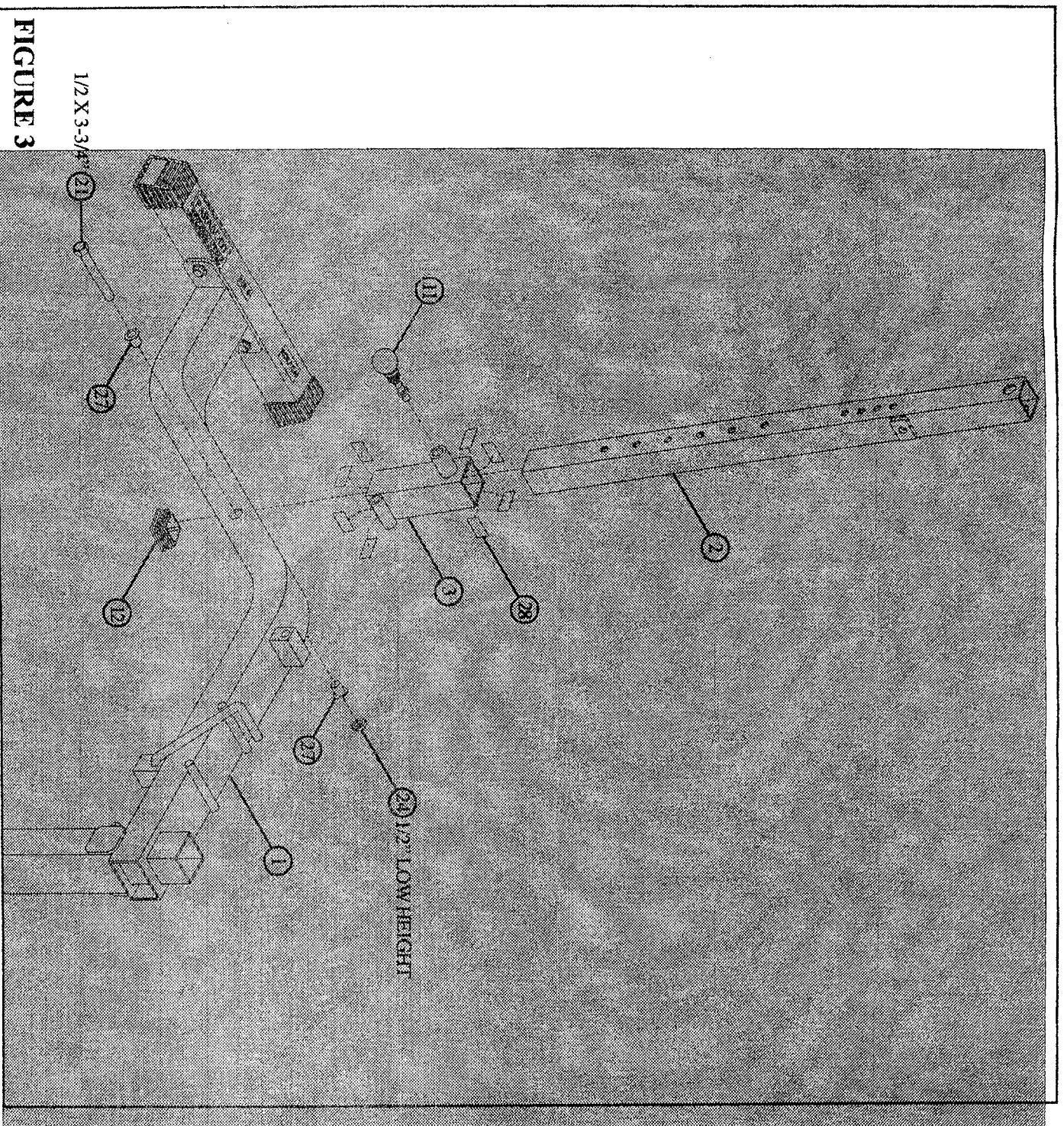
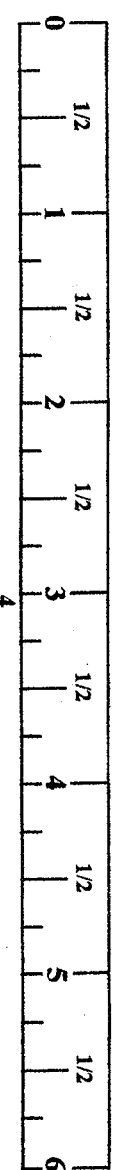

FIGURE 3

STEP 3:

- SECURELY assemble one SPRING PIN ASSEMBLY (11) to the spring pin barrel on the ADJUSTABLE SLEEVE (3). See FIGURE 3.
- Attach eight 3/4 X 1-1/2" GLIDES (28) to the inside of the ADJUSTABLE SLEEVE (3) as shown in FIGURE 3 using the following steps:
 - Thoroughly clean all surfaces where the 3/4 X 1-1/2" GLIDES (28) are to be attached.
 - Remove the 3/4 X 1-1/2" GLIDES (28) from the paper backing and firmly apply them to all shown surfaces.
- Assemble the ADJUSTABLE SLEEVE (3) to the BENCH FRAME (1) using one 1/2 X 3-3/4" BOLT (21), two 1/2" FLANGE SPACERS (27), and one 1/2" LOW HEIGHT LOCK NUT (24) as shown in FIGURE 3.
- Pull back on the SPRING PIN (11) and CAREFULLY insert the ADJUSTABLE SLIDE (2) into the ADJUSTABLE SLEEVE (3) as shown in FIGURE 3.
- Insert one 1-3/4" END CAP (12) into the end of the ADJUSTABLE SLIDE (2) as shown in FIGURE 3.

PERABODY

Serious Steel

874106 MULTI-ANGLE BENCH

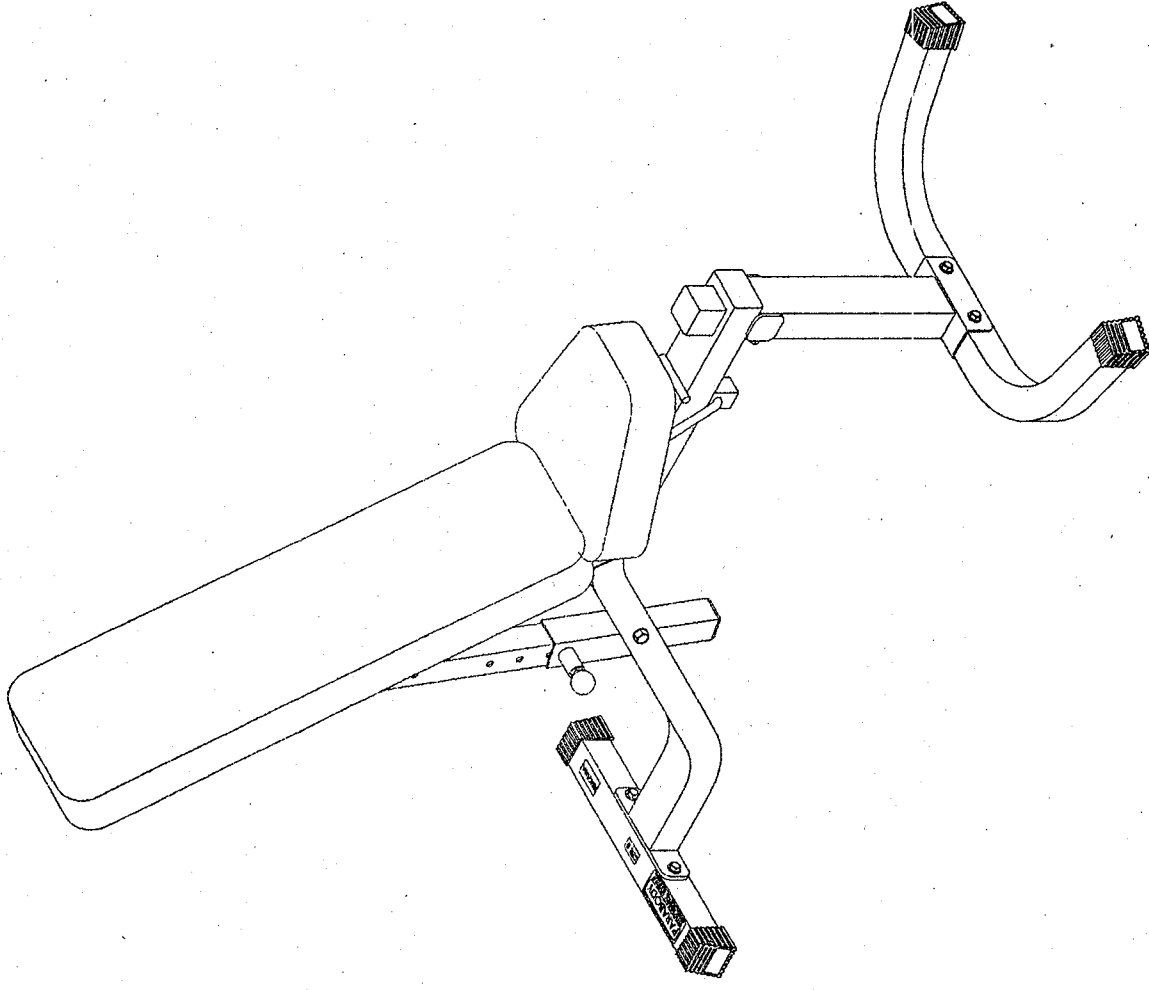

ASSEMBLY INSTRUCTIONS

IMPORTANT NOTES

WELCOME TO THE WORLD OF Serious steel!

Please note:

* Thank you for purchasing the Parabody 874101 MULTI-ANGLE BENCH. Please read these instructions thoroughly and keep them for future reference. This product must be assembled on a flat, level surface to assure its proper function.

We recommend cleaning your product (pads and frame) on a regular basis, using warm soapy water. Touch-up paint can be purchased from your Parabody customer service representative at (800) 328-9714.

There is a risk assumed by individuals who use this type of equipment. To minimize risk, please follow these rules:

1. Inspect equipment daily. Tighten all loose connections and replace worn parts immediately. Failure to do so may result in serious injury.
2. Do not allow minors or children to play on or around this equipment.
3. Exercise with care to avoid injury.
4. If unsure of proper use of equipment, call your local Parabody distributor or call the Parabody customer service department at (800) 328-9714.
5. Consult a physician before beginning any exercise program.

Tools Required for Assembly

- * 3/4" wrench
- * 9/16" wrench
- * Ratchet with 3/4" and 9/16" sockets
- * Adjustable wrench
- * Tape measure

Bolt Length Ruler

NOTE: BOLT LENGTH IS MEASURED FROM THE UNDERSIDE OF THE HEAD OF THE BOLT.

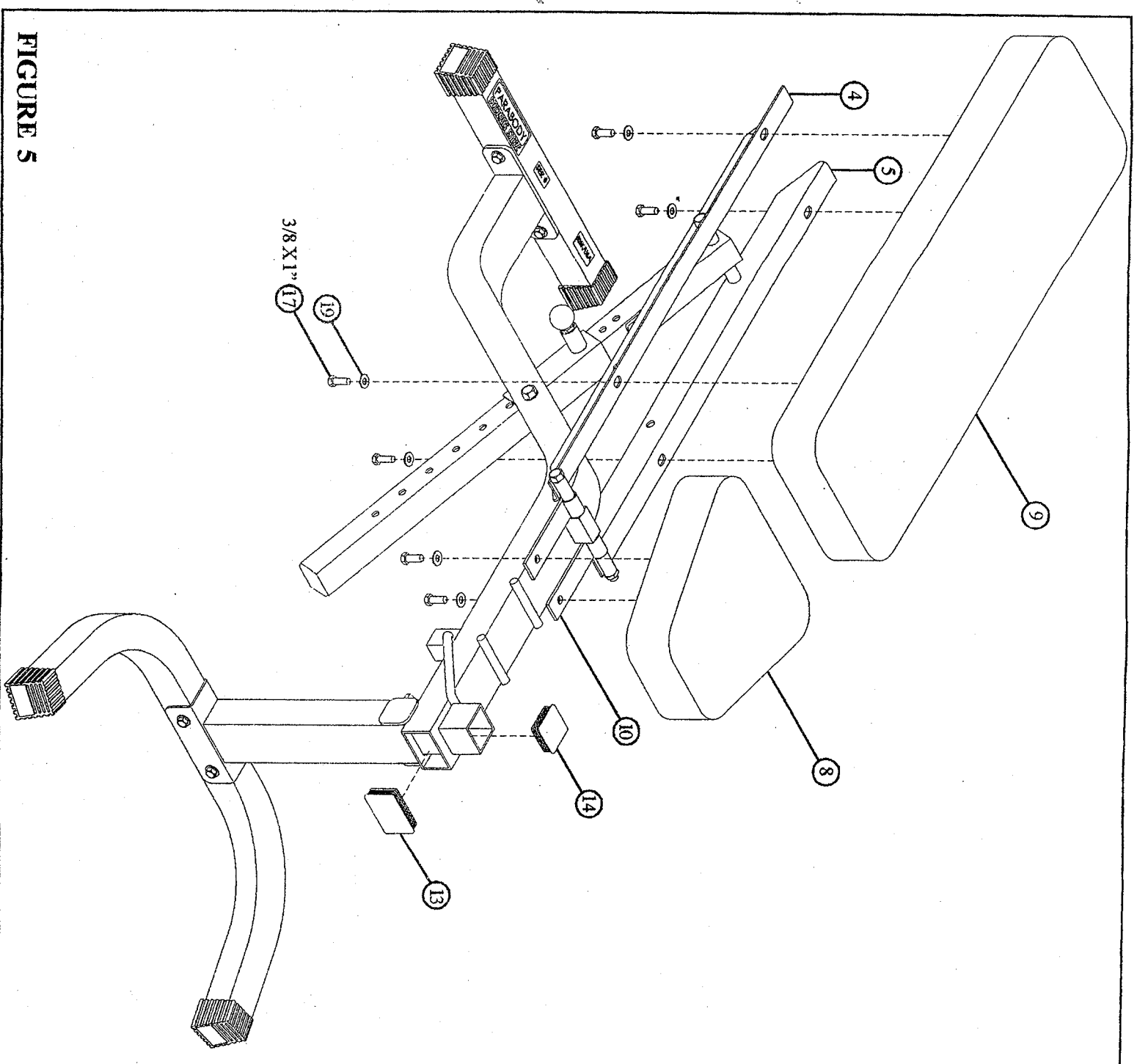
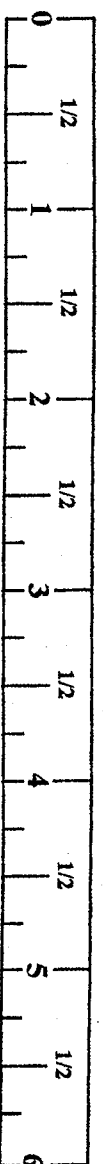
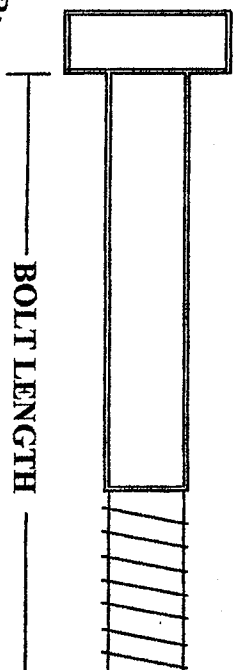

FIGURE 5

STEP 5:

- SECURELY assemble the SEAT PAD (8) to the HINGE TABS (10) using two 3/8 X 1" BOLTS (17) and two 3/8" WASHERS (19) as shown in FIGURE 5.
- SECURELY assemble the BACK PAD (9) to the LEFT BACK PAD ANGLE (4) and the RIGHT BACK PAD ANGLE (5) using four 3/8 X 1" BOLTS (17) and four 3/8" WASHERS (19) as shown in FIGURE 5.
- Slide one 2" SQ. END CAP (14) into the top of the BENCH FRAME (1) as shown in FIGURE 5.
- Slide one 3 X 2" END CAP (13) into the front of the BENCH FRAME (1) as shown in FIGURE 5.

Thank you for purchasing the Parabody 874101 MULTI-ANGLE BENCH. If unsure of proper use of equipment, call your local Parabody distributor or call the Parabody customer service department at (800) 328-9714.

PARTS LIST

| KEY | PART # | DESCRIPTION | QTY | KEY | PART # | DESCRIPTION | QTY |
|-----|---------|----------------------|-----|-----|---------|----------------------------|-----|
| 1 | 6650603 | BENCHFRAME | 1 | 16 | 6145801 | THUMBSCREW | 1 |
| 2 | 6650103 | ADJUSTABLE SLIDE | 1 | 17 | 3102909 | 3/8 X 1" BOLT | 6 |
| 3 | 6649303 | ADJUSTABLE SLEEVE | 1 | 18 | 3102904 | 3/8 X 3" BOLT | 4 |
| 4 | 6624202 | LEFT BACK PAD ANGLE | 1 | 19 | 3102501 | 3/8" WASHER | 14 |
| 5 | 6624302 | RIGHT BACK PAD ANGLE | 1 | 20 | 3102802 | 3/8" LOCK NUT | 4 |
| 6 | 6259103 | FRONT BASE | 1 | 21 | 3102960 | 1/2 X 3-3/4" BOLT | 1 |
| 7 | 6575003 | REAR BASE | 1 | 22 | 3102949 | 1/2 X 5-1/2" BOLT | 1 |
| 8 | 6654502 | SEAT PAD | 1 | 23 | 3202104 | 1/2 X 8" BOLT | 1 |
| 9 | 6654402 | BACK PAD | 1 | 24 | 3102804 | 1/2" LOW HEIGHT LOCK NUT | 3 |
| 10 | 6406401 | HINGE TAB | 2 | 25 | 3109602 | 1/2" PAL NUT | 1 |
| 11 | 6412001 | SPRING PIN ASSEMBLY | 1 | 26 | 6417801 | 1/2 X 1" SPRING | 1 |
| 12 | 6236701 | 1-3/4" SQ. END CAP | 1 | 27 | 6650201 | 1/2" FLANGE SPACER | 2 |
| 13 | 6692601 | 3 X 2" END CAP | 1 | 28 | 6416601 | 1-1/2 X 3/4" GLIDE (8 PER) | 1 |
| 14 | 6405201 | 2" SQ. END CAP | 1 | 29 | 6406501 | 1/2" DIA U-PIN | 1 |
| 15 | 6467001 | 2" SQ. COVER CAP | 4 | | | | |

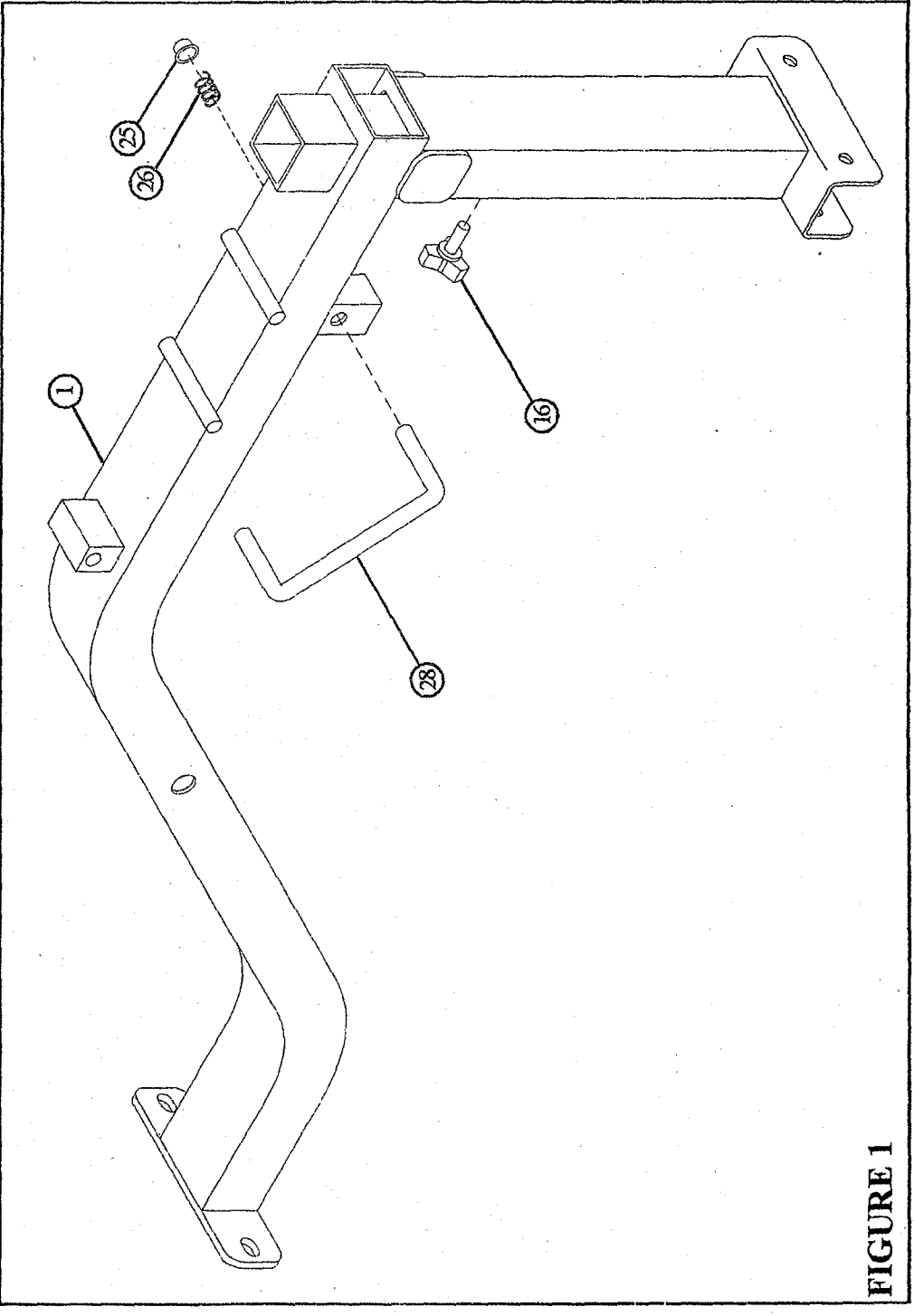

FIGURE 1

STEP 1:

- Assemble the 1/2" DIA. U-PIN (29) to the BENCHFRAME (1) using one 1/2 X 1" SPRING (26), and one 1/2" PAL NUT (25) as shown in FIGURE 1.
- Thread one THUMBSCREW (16) into the BENCHFRAME (1) as shown in FIGURE 1. The THUMBSCREW (16) will be used to tighten down attachments.

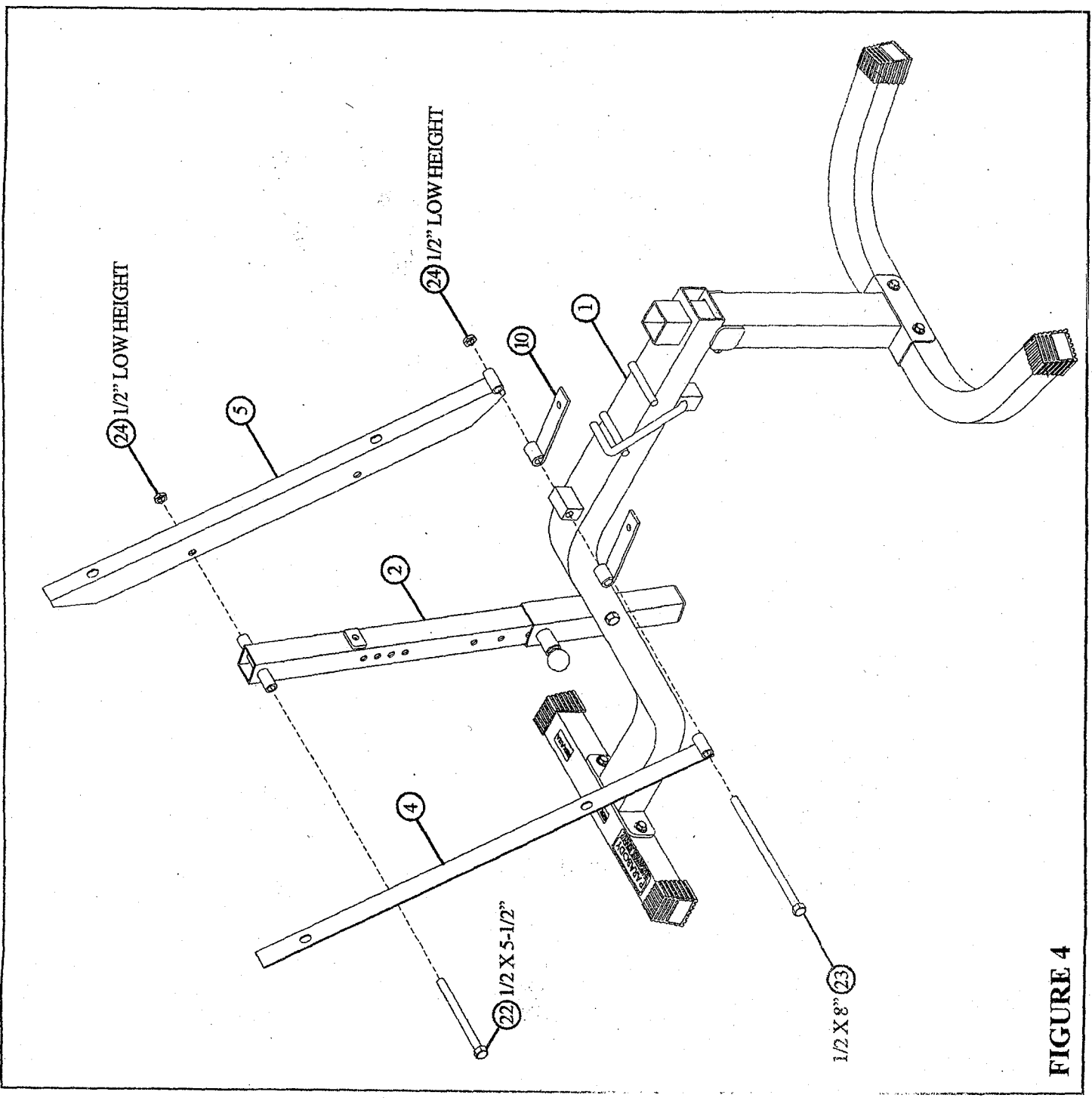
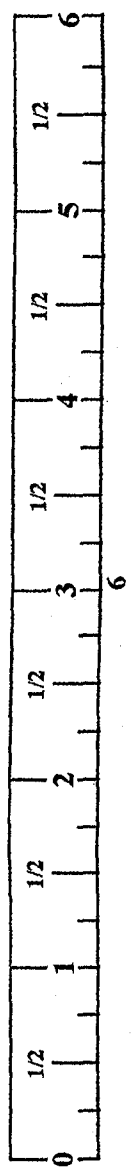

FIGURE 4

STEP 4:

- Assemble the LEFT and RIGHT BACK PAD ANGLE (4 & 5) and two HINGE TABS (10) to the BENCHFRAME (1) using one 1/2 X 8" BOLT (23) and one 1/2" LOW HEIGHT LOCK NUT (24) as shown in FIGURE 4.
- Assemble the LEFT and RIGHT BACK PAD ANGLE (4 & 5) to the ADJUSTABLE SLIDE (2) using one 1/2 X 5-1/2" BOLT (22) and one 1/2" LOW HEIGHT LOCK NUT (24) as shown in FIGURE 4.



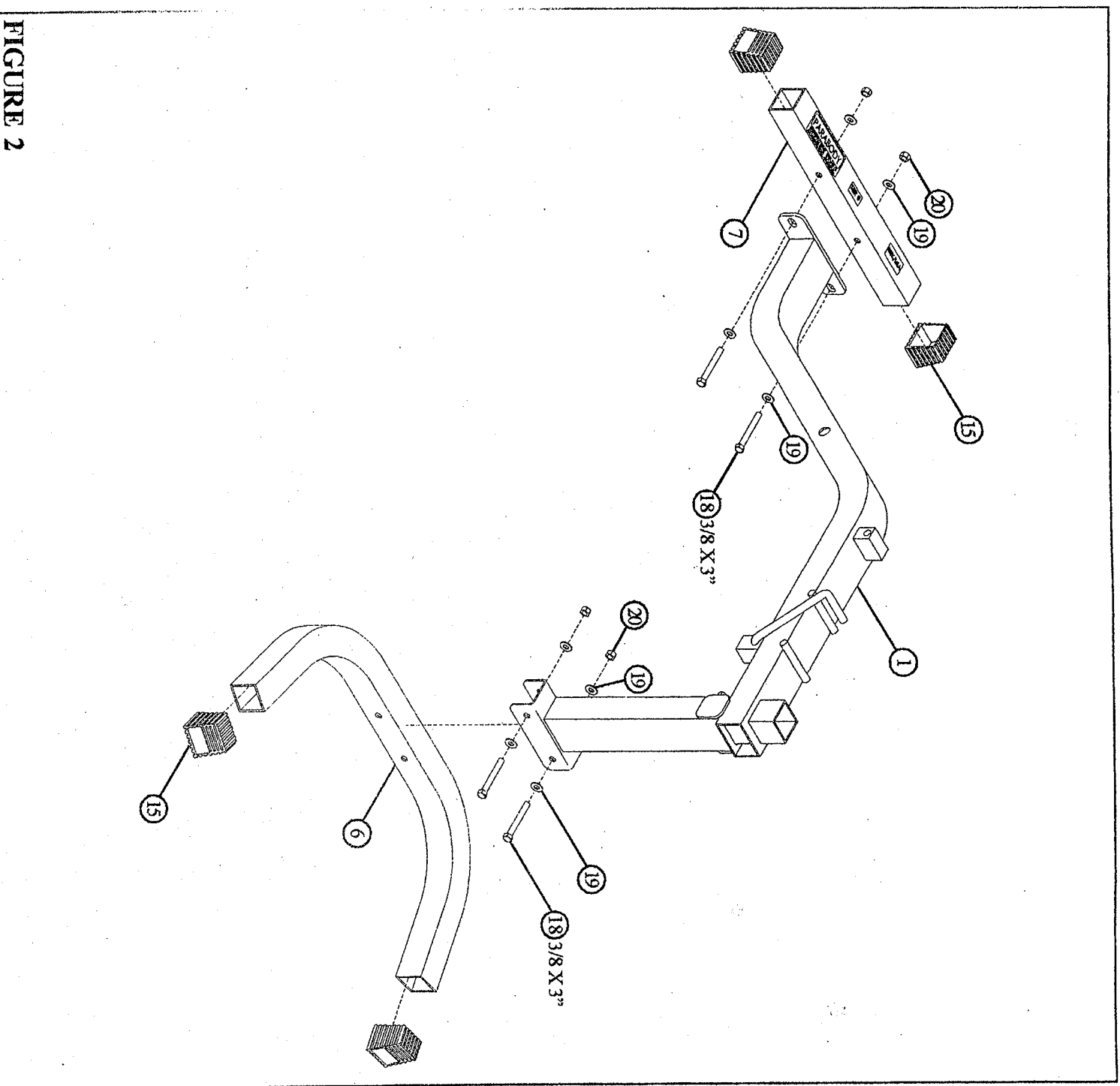

FIGURE 2

STEP 2:

- Slide four 2" SQ. COVER CAPS (15) over the ends of the FRONT & REAR BASE (6 & 7) as shown in FIGURE 2.
- SECURELY assemble the FRONT BASE (6) to the BENCH FRAME (1) using two 3/8 X 3" BOLTS (18), four 3/8" WASHERS (19), and two 3/8" LOCK NUTS (20). See FIGURE 2.
- SECURELY assemble the REAR BASE (7) to the BENCH FRAME (1) using two 3/8 X 3" BOLTS (18), four 3/8" WASHERS (19), and two 3/8" LOCK NUTS (20). See FIGURE 2.

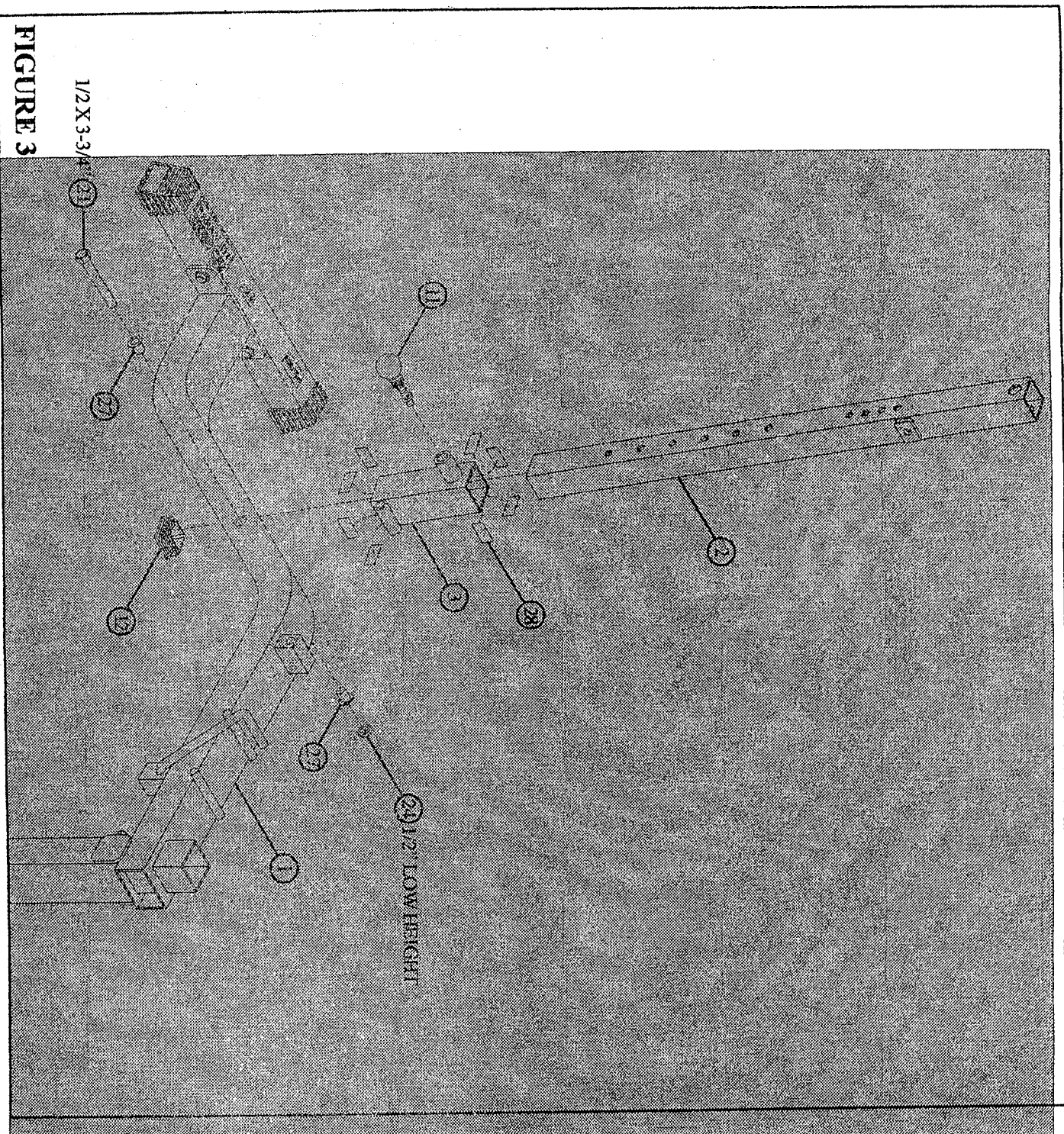
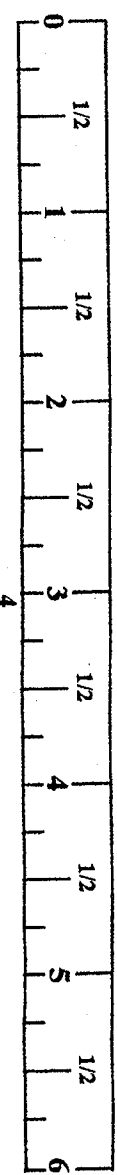

FIGURE 3

STEP 3:

- SECURELY assemble one SPRING PIN ASSEMBLY (11) to the spring pin barrel on the ADJUSTABLE SLEEVE (3). See FIGURE 3.
- Attach eight 3/4 X 1-1/2" GLIDES (28) to the inside of the ADJUSTABLE SLEEVE (3) as shown in FIGURE 3 using the following steps:
 - Thoroughly clean all surfaces where the 3/4 X 1-1/2" GLIDES (28) are to be attached.
 - Remove the 3/4 X 1-1/2" GLIDES (28) from the paper backing and firmly apply them to all shown surfaces.
- Assemble the ADJUSTABLE SLEEVE (3) to the BENCH FRAME (1) using one 1/2 X 3-3/4" BOLT (21), two 1/2" FLANGE SPACERS (27), and one 1/2" LOW HEIGHT LOCK NUT (24) as shown in FIGURE 3.
- Pull back on the SPRING PIN (11) and CAREFULLY insert the ADJUSTABLE SLIDE (2) into the ADJUSTABLE SLEEVE (3) as shown in FIGURE 3.
- Insert one 1-3/4" END CAP (12) into the end of the ADJUSTABLE SLIDE (2) as shown in FIGURE 3.