

PARABODY

Serious Steel

897104 WEIGHT STACK OPTION

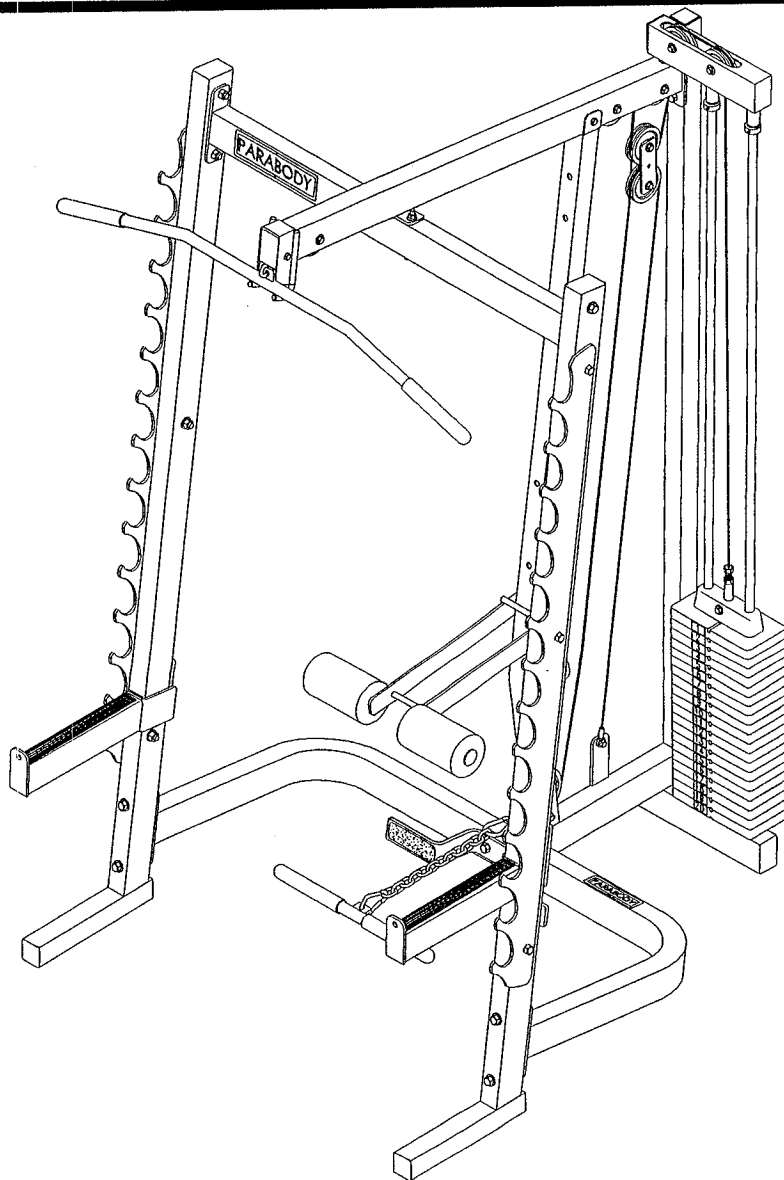

ASSEMBLY INSTRUCTIONS

PARTS LIST

KEY	PART #	DESCRIPTION	QTY	KEY	PART #	DESCRIPTION	QTY
1	6xxxx	STACK BASE	1	14	6480301	3/8" FLANGE SPACER	4
2	6819403	STACK BOOM	1	15	3102501	3/8" WASHER	1
3	6819703	1-3/4" X 9-3/8" TUBE	1	16	3102802	3/8" LOCK NUT	2
4	6577801	77-1/4" GUIDE ROD	2	17	3102953	1/2 X 2-3/4" BOLT	1
5	6284501	20 HOLE WEIGHT STACK SHAFT	1	18	3102918	1/2 X 3-1/4" BOLT	1
6	3116201	3-1/2" PULLEY	2	19	3102502	1/2" WASHER	2
7	6660101	129-1/2" CABLE	1	20	3102801	1/2" LOCK NUT	2
8	6692601	3 X 2" END CAP	4	21	3108002	WEIGHT STACK CUSHION	2
9	3103302	13/16" SHAFT COLLAR	2	22	6595201	GUIDE ROD BUSHING	2
10	6214401	WEIGHT STACK SELECTOR PIN	1	23	6382301	WEIGHT PLATE BUSHING (10 CT)	4
11	6236701	1-3/4" SQ. END CAP	1	24	6714601	HEAD PLATE	1
12	3102901	3/8 X 1-1/4" BOLT	1	25	6214501	WEIGHT PLATE	20
13	3102922	3/8 X 2-3/4" BOLT	2	26	6198501	WEIGHT STACK LABELS (1-25)	1

FIGURE 1

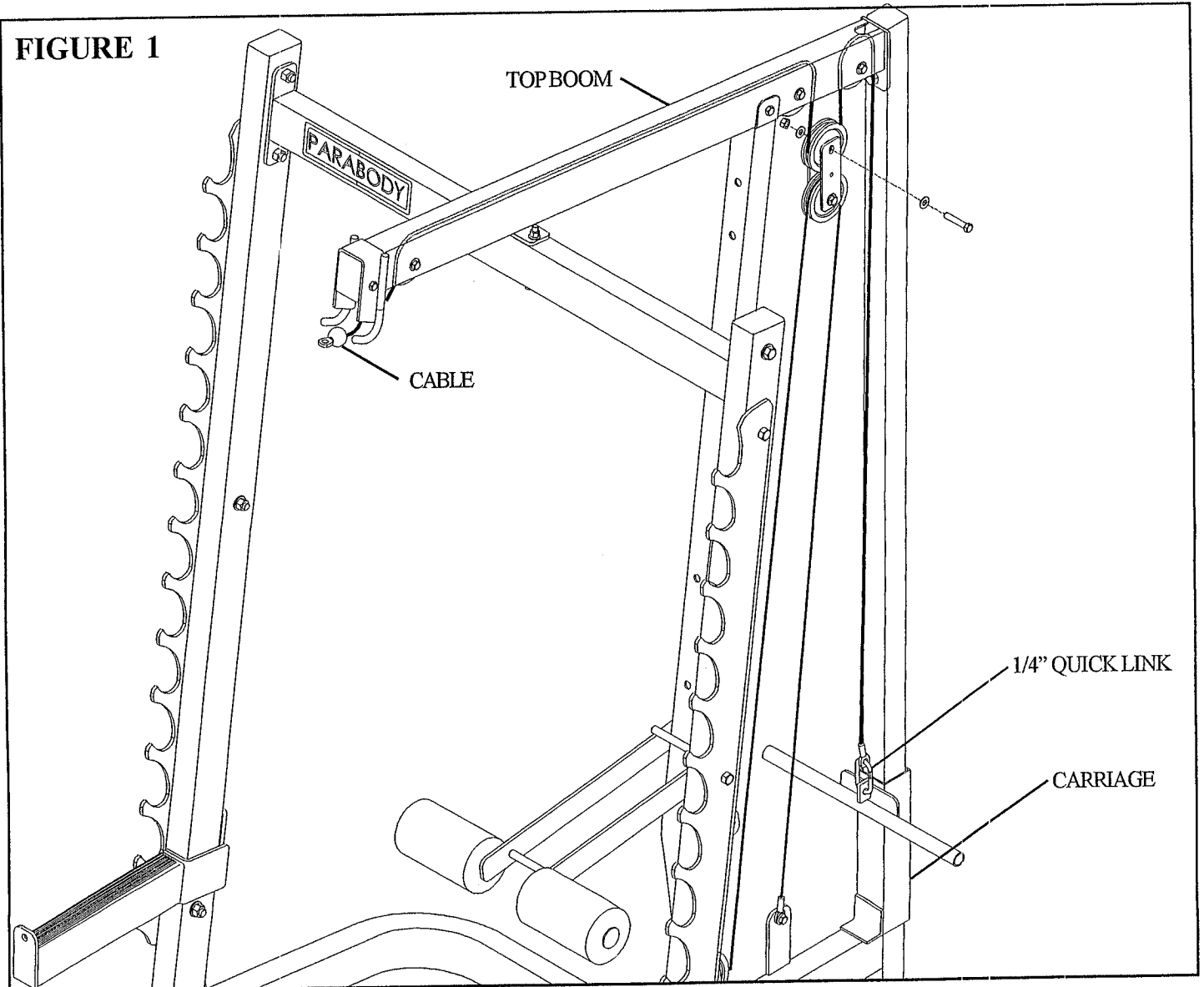

STEP 1:

- Remove the CABLE and the 1/4" QUICK LINK from the CARRIAGE as shown in FIGURE 1.
- Remove CABLE and the 1/4" QUICK LINK from the TOP BOOM as shown in FIGURE 1 and discard. (NOTE: PULLEYS may have to be loosened or removed to allow CABLE to pass through.)

IMPORTANT NOTES

WELCOME TO THE WORLD OF ***Serious Steel!***

Please note:

* Thank you for purchasing the Parabody 897104 WEIGHT STACK OPTION. Please read these instructions thoroughly and keep them for future reference. This product must be assembled on a flat, level surface to assure its proper function.

We recommend cleaning your product (pads and frame) on a regular basis, using warm soapy water. Touch-up paint can be purchased from your Parabody customer service representative at (800) 328-9714.

There is a risk assumed by individuals who use this type of equipment. To minimize risk, please follow these rules:

1. Inspect equipment daily. Tighten all loose connections and replace worn parts immediately. Failure to do so may result in serious injury.
2. Do not allow minors or children to play on or around this equipment.
3. Exercise with care to avoid injury.
4. If unsure of proper use of equipment, call your local Parabody distributor or call the Parabody customer service department at (800) 328-9714.
5. Consult a physician before beginning any exercise program.

Tools Required for Assembly

- * 3/4" wrench
- * 9/16" wrench
- * 5/32 Allen wrench
- * Ratchet with 3/4" and 9/16" sockets
- * Adjustable wrench
- * Tape measure

Bolt Length Ruler

NOTE: BOLT LENGTH IS MEASURED FROM THE UNDERSIDE OF THE HEAD OF THE BOLT.

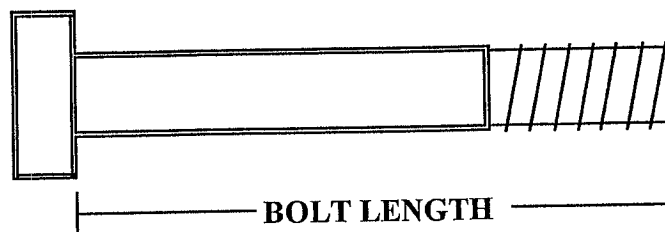

BOLT LENGTH RULER:

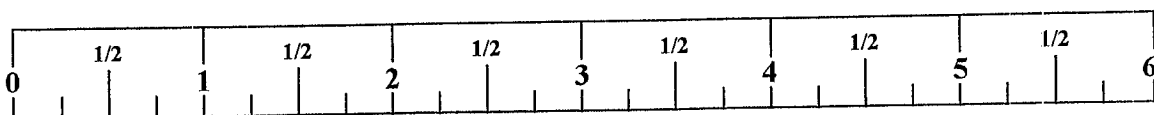

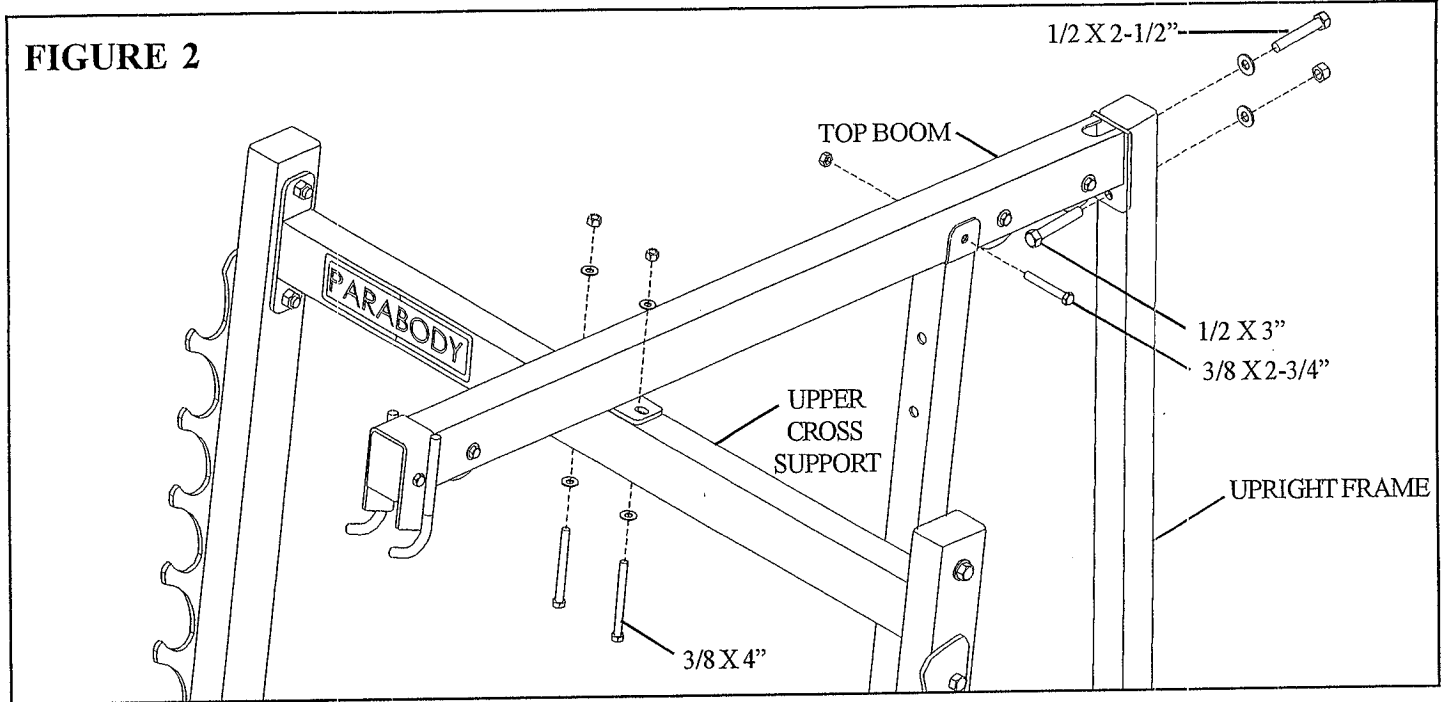

STEP 2:

- **LOOSEN** the TOP BOOM from the UPRIGHT FRAME by removing one 1/2 X 2-1/2" BOLT, one 1/2 X 3" BOLT, one 3/8 X 2-3/4" BOLT, two 1/2" WASHERS, one 1/2" LOCK NUT, and one 3/8" LOCK NUT as shown in FIGURE 2.
- **LOOSEN** the TOP BOOM from the UPPER CROSS SUPPORT by removing two 3/8 X 4" BOLTS, four 3/8" WASHERS and two 3/8" LOCK NUTS. See FIGURE 2.
- **REMOVE TOP BOOM.**

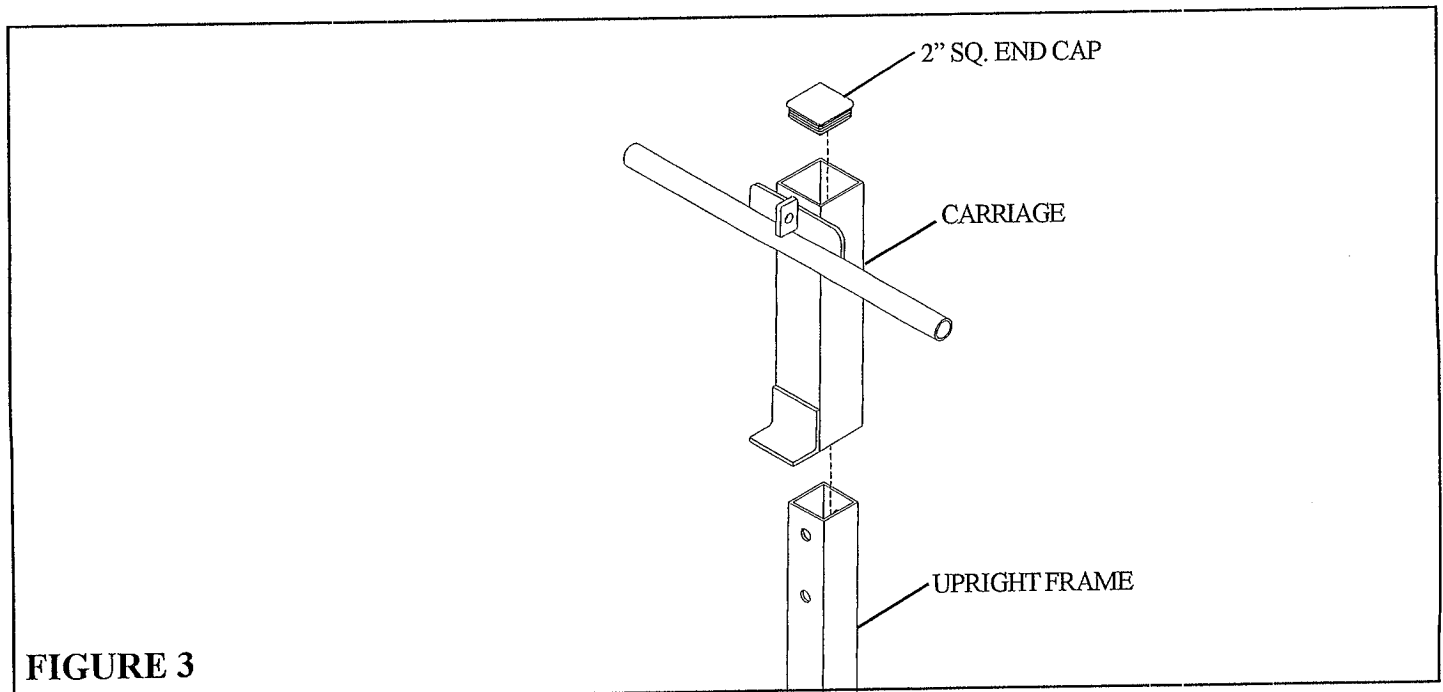
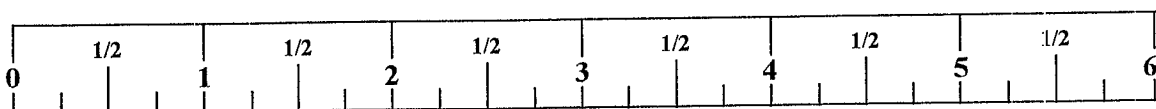

FIGURE 3

STEP 3:

- Remove and discard one 2" SQ. END CAP from the end of the UPRIGHT FRAME as shown in FIGURE 3.
- Slide the CARRIAGE off the UPRIGHT FRAME and discard as shown in FIGURE 3.



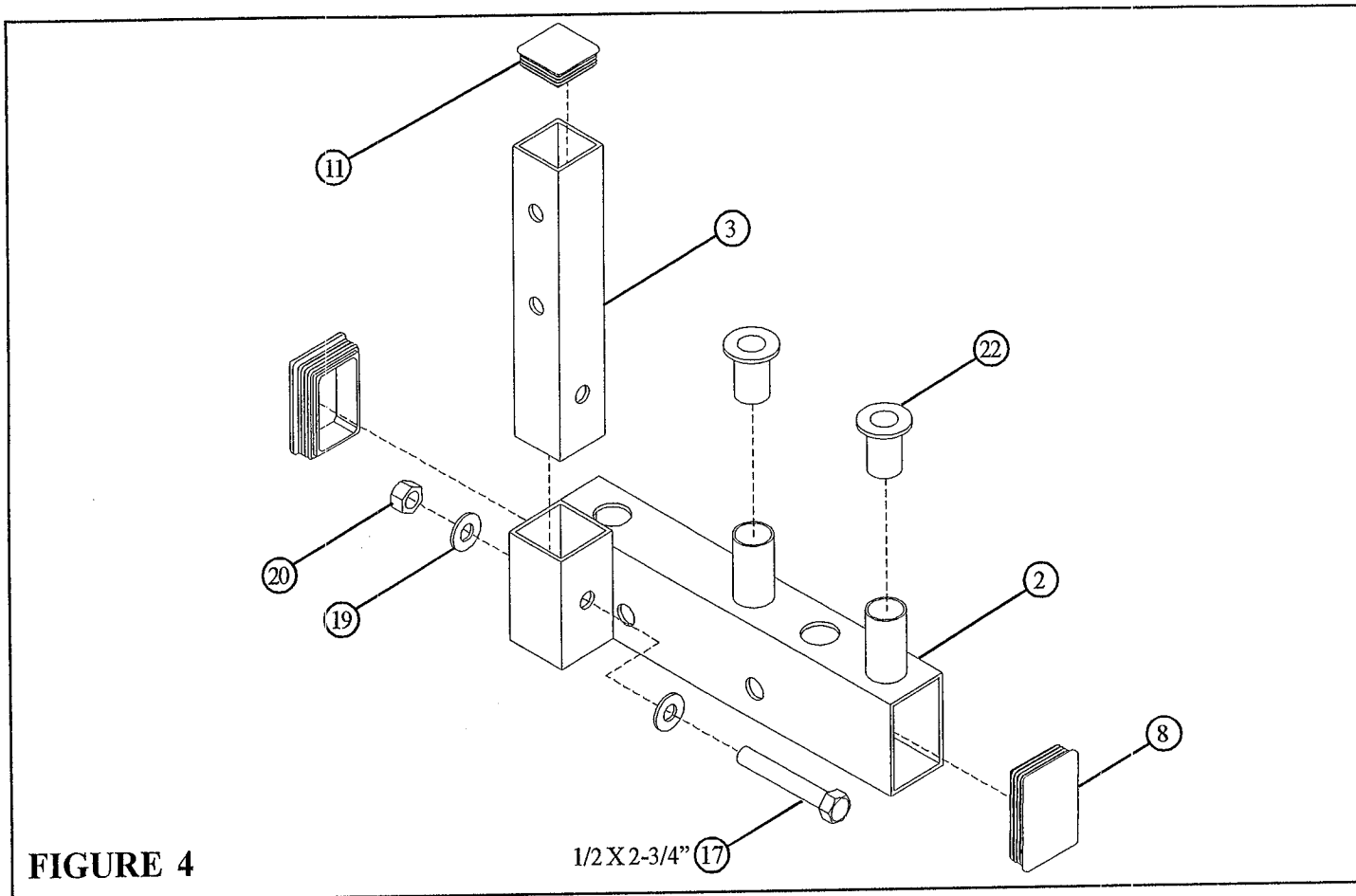

FIGURE 4

STEP 4:

- Insert two 3 X 2" END CAPS (8) into the ends of the STACK BOOM (2) as shown in FIGURE 4.
- Insert two GUIDE ROD BUSHINGS (22) into the tubes on the STACK BOOM (2) as shown in FIGURE 4.
- **SECURELY** assemble the 1-3/4 X 9-3/8" TUBE (3) to the STACK BOOM (2) using one 1/2 X 2-3/4" BOLT (17), two 1/2" WASHERS (19), and one 1/2" LOCK NUT (20) as shown in FIGURE 4.
- Insert one 1-3/4" END CAP (11) into the 1-3/4 X 9-3/8" TUBE (3) as shown in FIGURE 4.

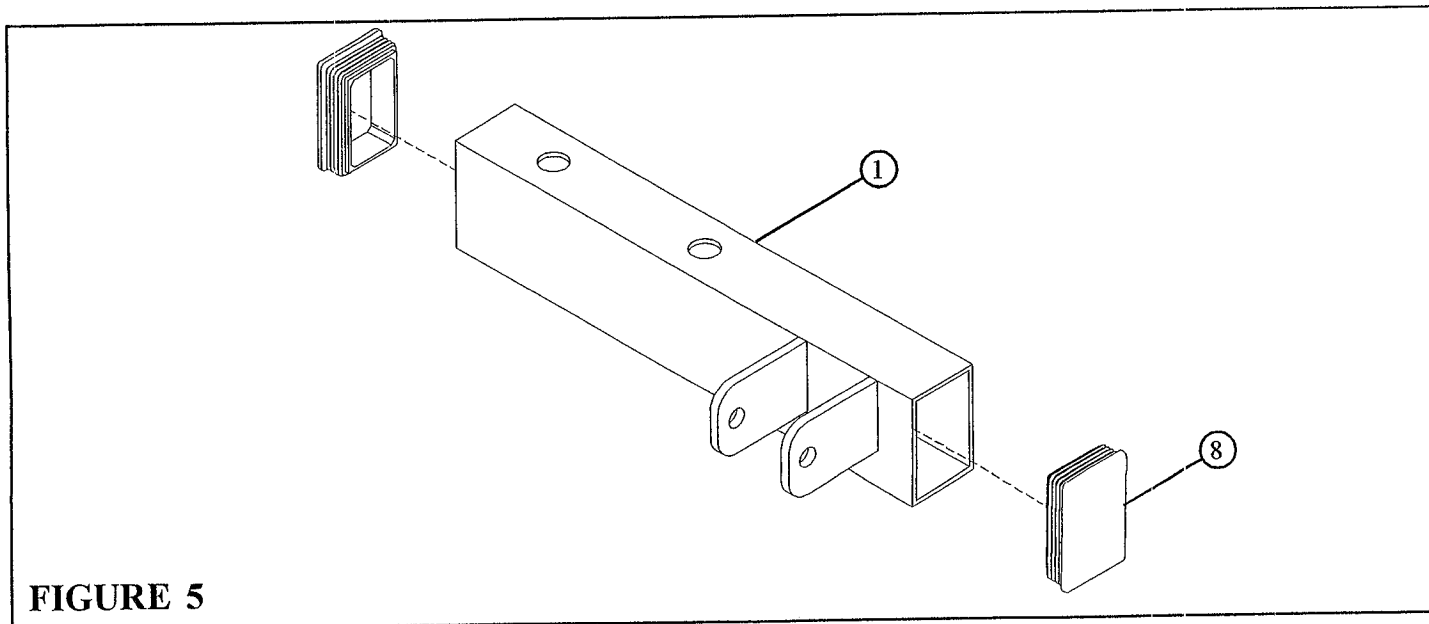
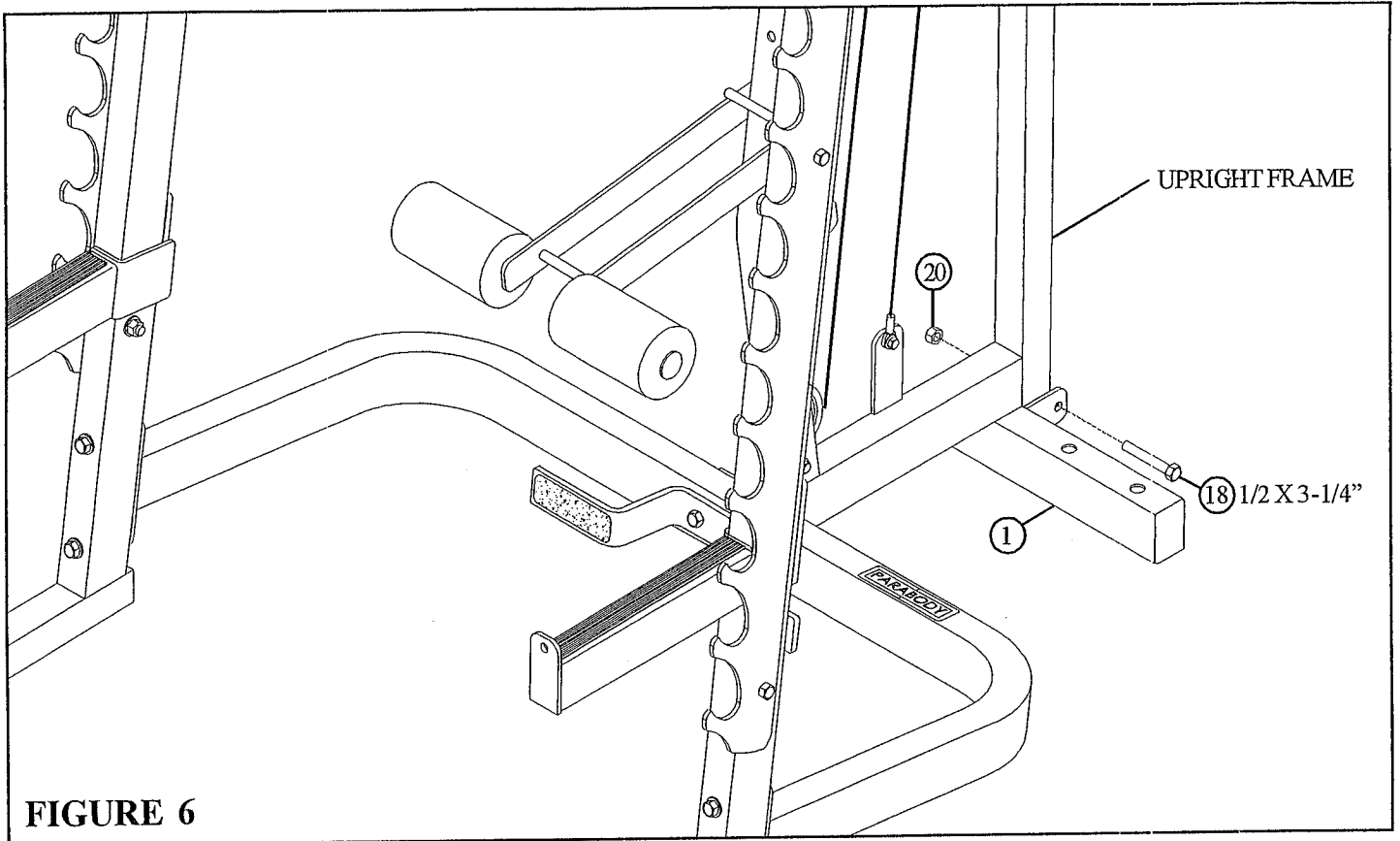

FIGURE 5

STEP 5:

- Insert two 3 X 2" END CAPS (8) into the ends of the STACK BASE (1) as shown in FIGURE 5.



STEP 6:

- **SECURELY** assemble the STACK BASE (1) to the bottom of the UPRIGHT FRAME using one 1/2 X 3-1/4" BOLT (18) and one 1/2" LOCK NUT (20) as shown in FIGURE 6.

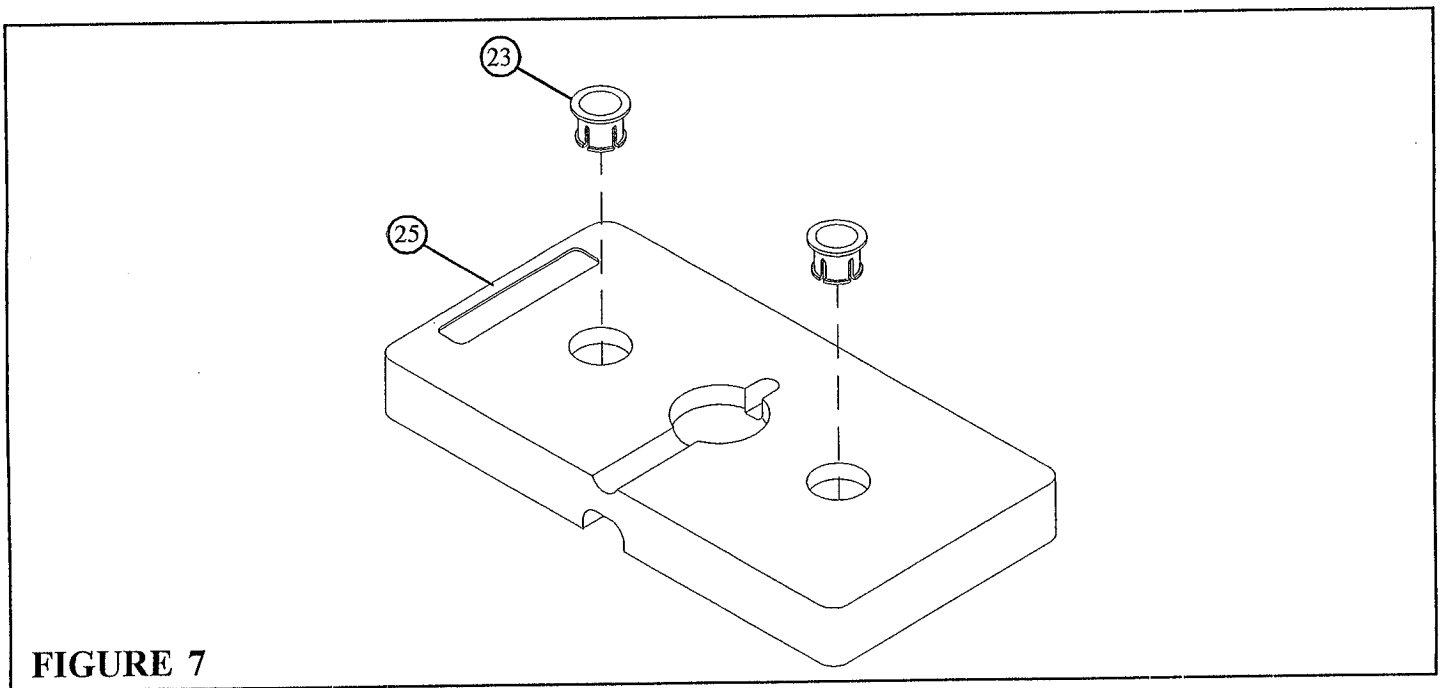

STEP 7:

- Snap two WEIGHT PLATE BUSHINGS (23) into the top of all twenty WEIGHT PLATES (25) as shown in FIGURE 7.

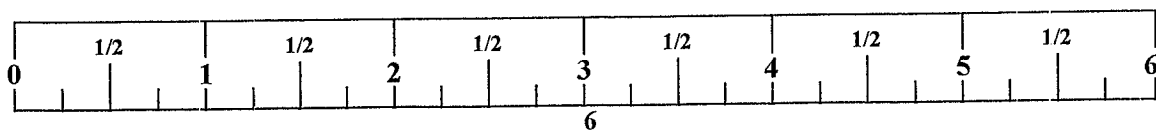

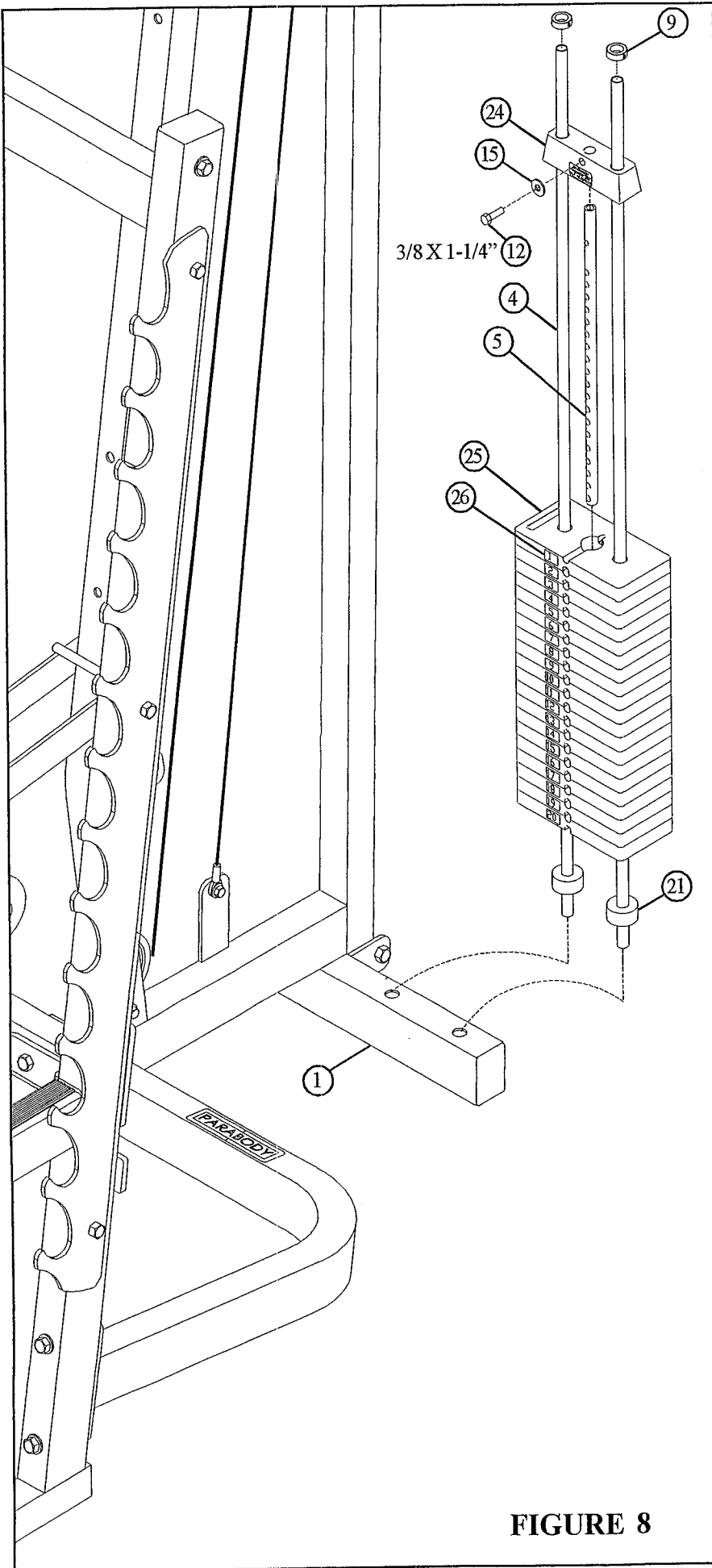

STEP 8:

- Insert two GUIDE RODS (4) into the STACK BASE (1) as shown in FIGURE 8. Lubricate the GUIDE RODS (4) with a silicon or teflon spray that is available at most hardware stores.
- Slide two WEIGHT STACK CUSHIONS (21) down over the GUIDE RODS (4). See FIGURE 8.
- Using **EXTREME CARE** slide twenty WEIGHT PLATES (25) down over the GUIDE RODS (4) with the key-hole facing as shown in FIGURE 8.
- Securely assemble the 20 HOLE SELECTOR SHAFT (5) to the HEAD PLATE (24) using one 3/8 X 1-1/4" BOLT (12) and one 3/8" WASHER (15). (Note: The bolt hole in the HEAD PLATE (24) should be on top.)
- Carefully Slide the HEAD PLATE ASSEMBLY (5 & 24) down over the GUIDE RODS (4) onto the weight stack as shown in FIGURE 8.
- Slide two 13/16" SHAFT COLLARS (9) over the GUIDE RODS (4) as shown in FIGURE 8.
- Apply one set of WEIGHT STACK LABELS - 1-25 (26) to each WEIGHT PLATE (25) as shown in FIGURE 8.

FIGURE 8

FIGURE 9

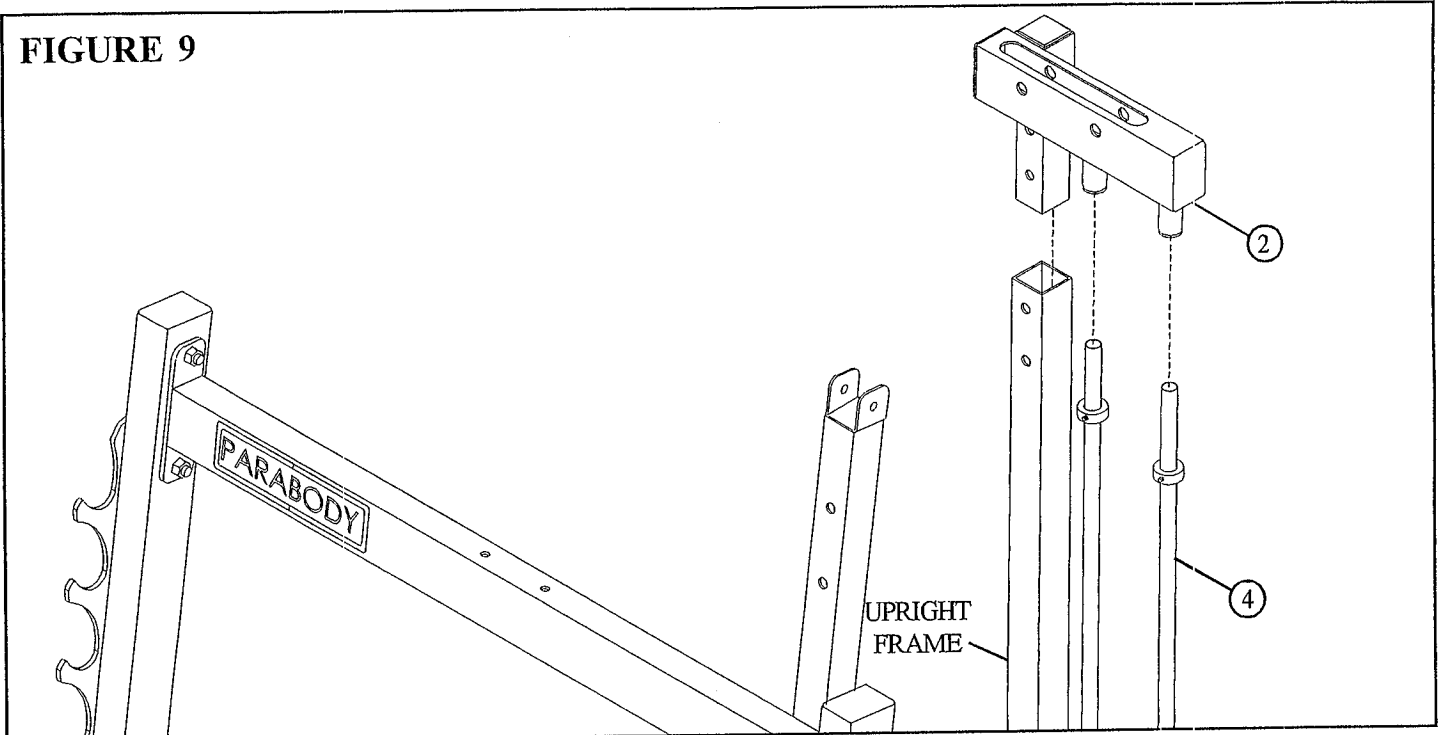

STEP 9:

- Slide the STACK BOOM (2) over the GUIDE RODS (4) and inside the tube on the UPRIGHT FRAME as shown in FIGURE 9.

FIGURE 10

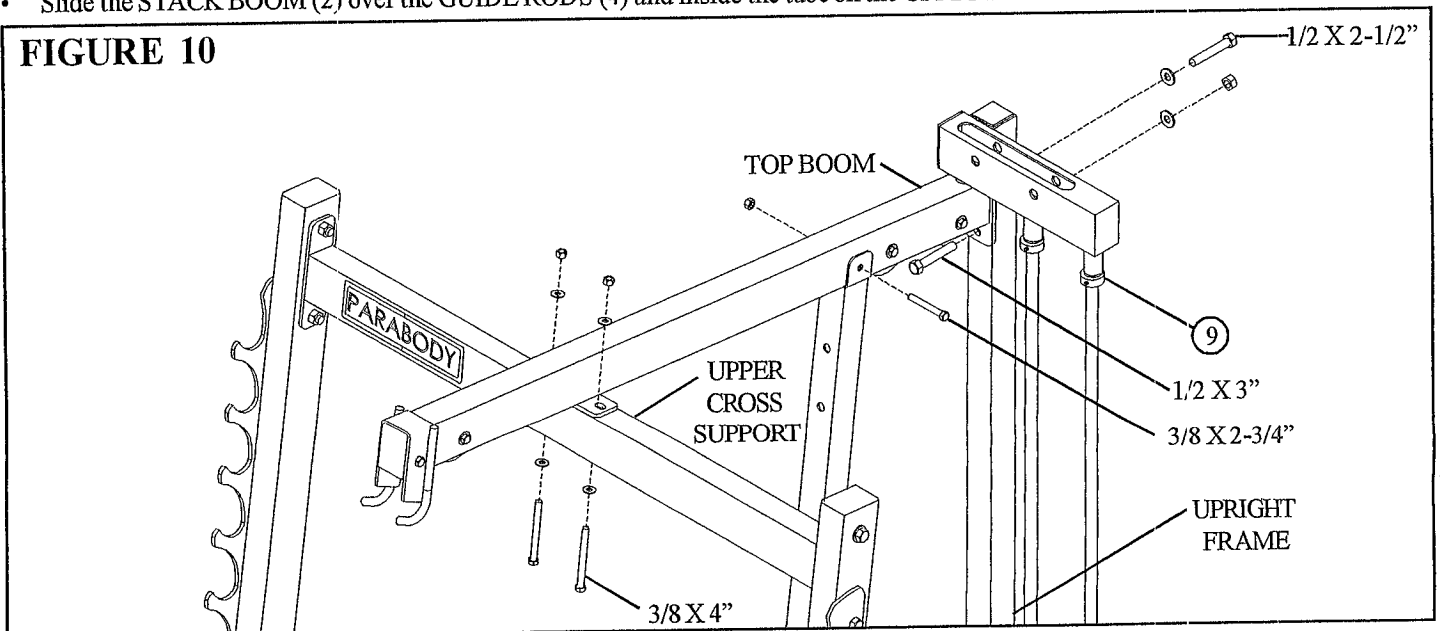

STEP 10:

- **LOOSLY** assemble the TOP BOOM to the UPRIGHT FRAME using the previously removed 1/2 X 2-1/2" BOLT, one 1/2 X 3" BOLT, one 3/8 X 2-3/4" BOLT, two 1/2" WASHERS, one 1/2" LOCK NUT, and one 3/8" LOCK NUT as shown in FIGURE 10.
- **LOOSELY** assemble the TOP BOOM to the UPPER CROSS SUPPORT using two previously removed 3/8 X 4" BOLTS, four 3/8" WASHERS, and two 3/8" LOCK NUTS. See FIGURE 10.
- Slide the 13/16" SHAFT COLLARS (9) to the top of the GUIDE RODS (4) and **SECURELY** tighten the SHAFT COLLAR (9) set screws. See FIGURE 10.
- **SECURELY** tighten all connections made up to this point.

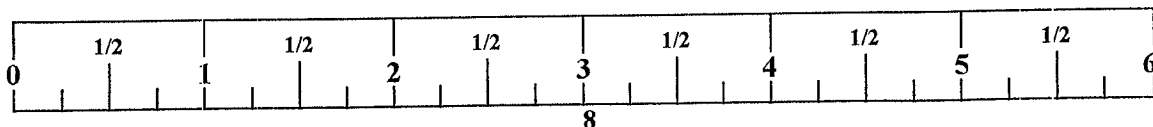
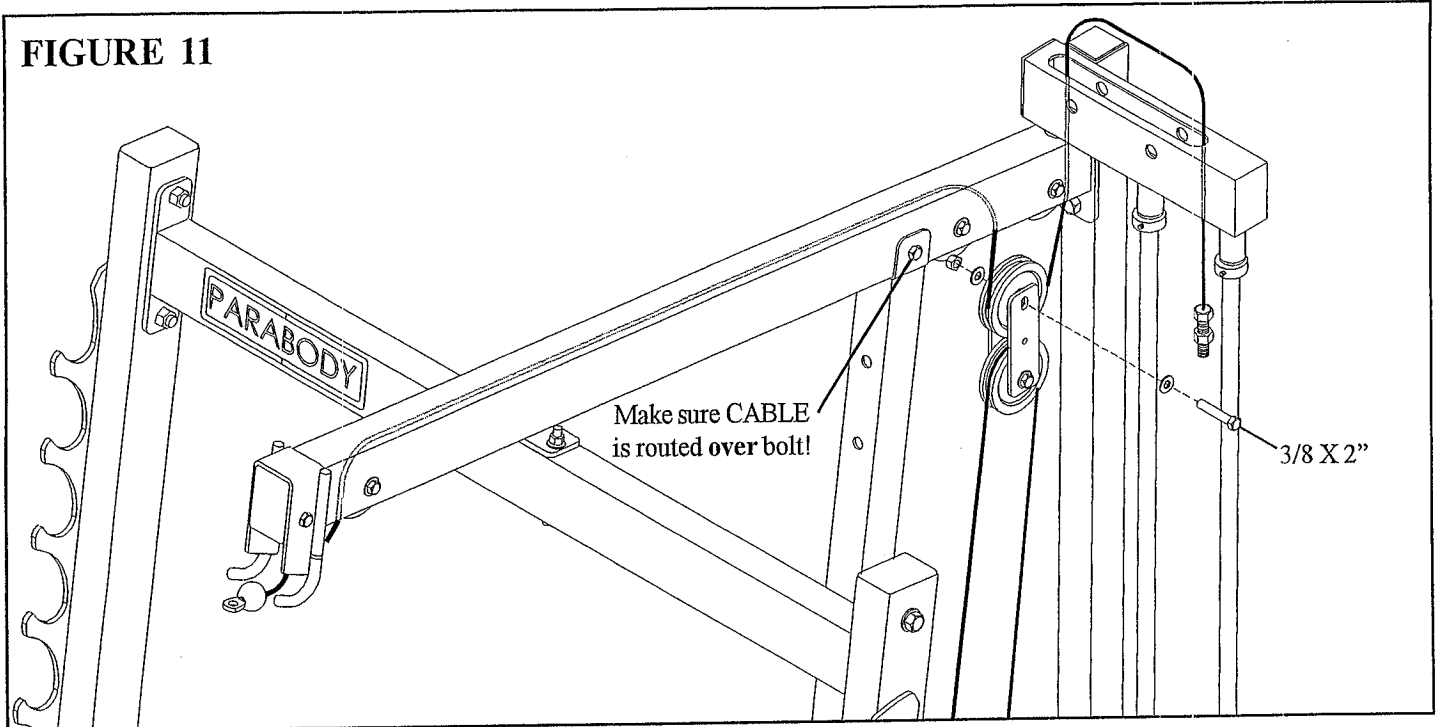

FIGURE 11



STEP 11:

- Route the 129-1/2" CABLE (7) through the TOP BOOM and the STACK BOOM (2) as shown in FIGURE 11.
- **TIGHTEN** any **LOOSENED** PULLEY connection after CABLE has been routed.

FIGURE 12

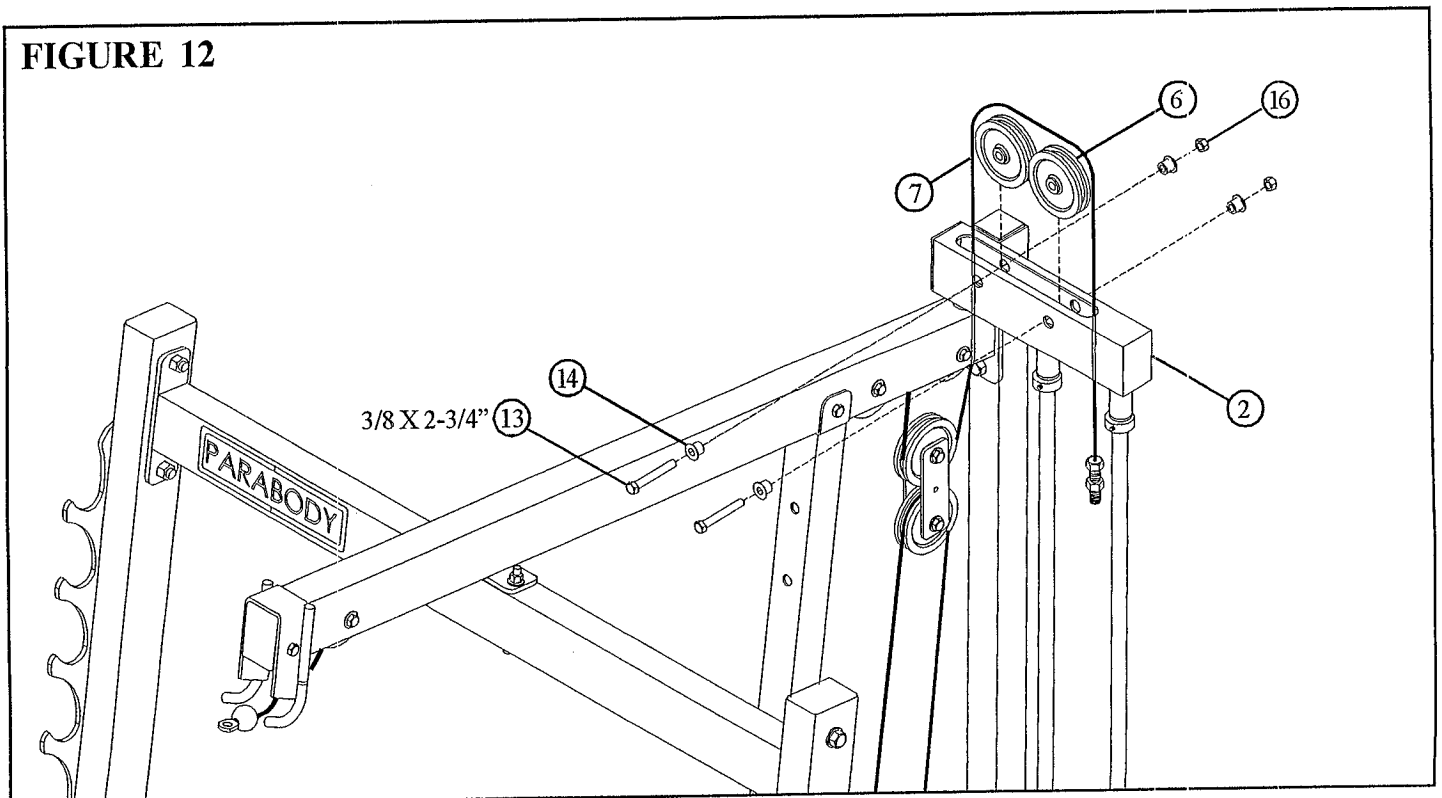

STEP 12:

- **SECURELY** assemble two 3-1/2" PULLEYS (6) to the STACK BOOM (2) using two 3/8 X 2-3/4" BOLTS (13), four 3/8" FLANGE SPACERS (14), and two 3/8" LOCK NUTS (16) as shown in FIGURE 12. (**NOTE: Make sure the cable is routed over all the pulleys.**)
- **TIGHTEN** any **LOOSENED** PULLEY connection after CABLE has been routed.

FIGURE 13

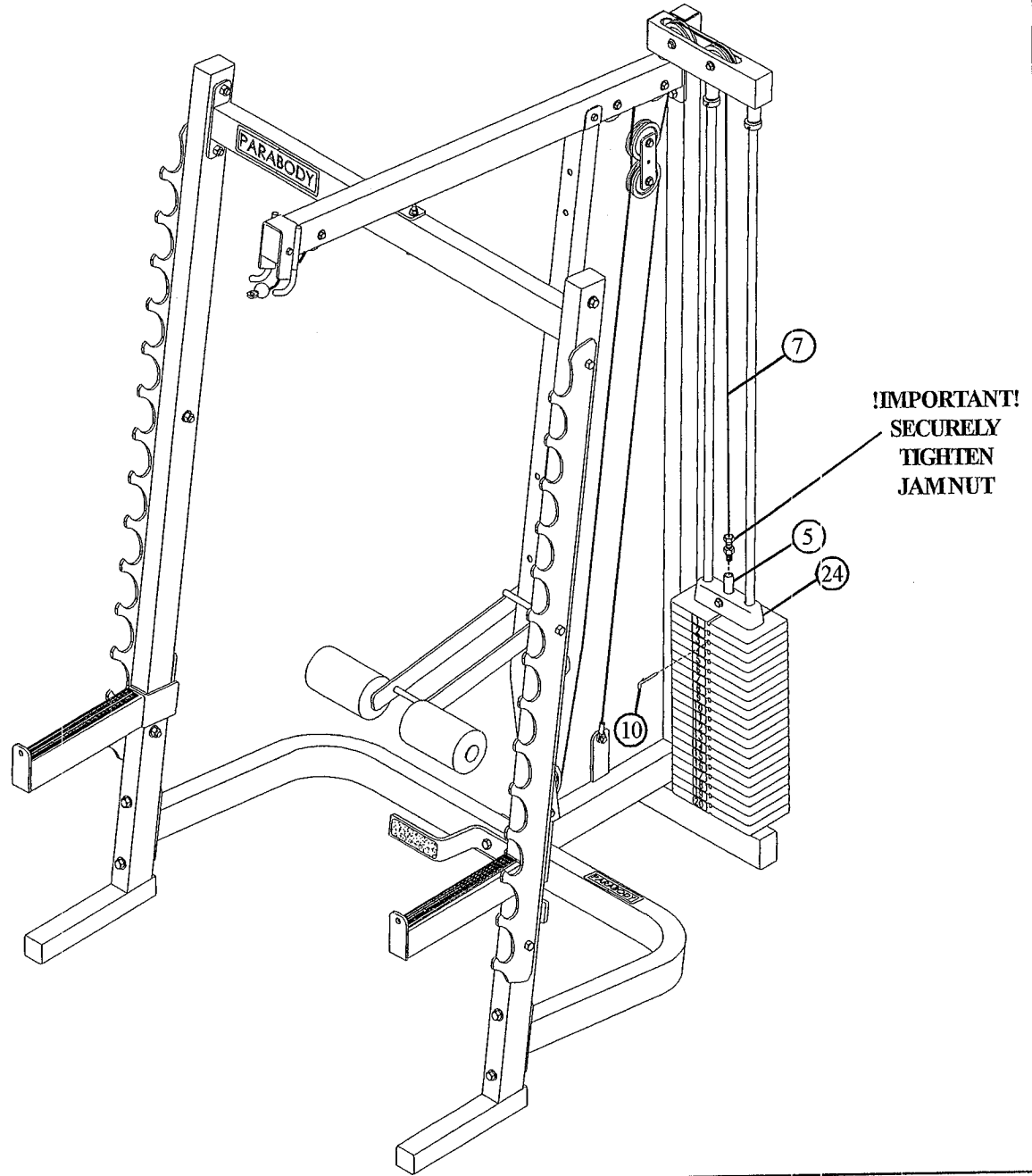

STEP 13:

- Screw the threaded end of the CABLE (7) approximately 3/4" into the end of the 20 HOLE SELECTOR SHAFT (5) and tighten jam nut securely. See FIGURE 13.
- Insert the WEIGHT STACK PIN (10) into the WEIGHT STACK as shown in FIGURE 13.
- If the HEAD PLATE (24) does not sit on top of the first WEIGHT PLATE (25), push the head plate down, insert the SELECTOR PIN (10) and perform several repetitions on the machine. This will relax the cable system and prevent the HEAD PLATE (24) from lifting up.
- If after completing the previous step the HEAD PLATE (24) still does not sit on top of the first WEIGHT PLATE (25) or if there is excess slack in the cable system, adjust the threaded end of the CABLE accordingly and retighten the jam nut.

Thank you for purchasing the Parabody 897104 WEIGHT STACK OPTION. If unsure of proper use of equipment, call your local Parabody distributor or call the Parabody customer service department at (800) 328-9714.

