

Operating Instructions

Variable Speed

Cordless

Drill & Driver

Model: EY6101

Model: EY6181

Model: EY6100

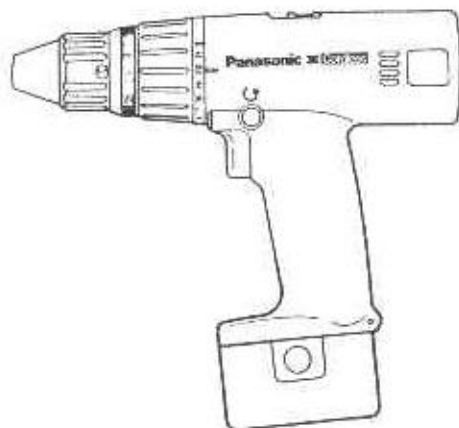

Panasonic

Before operating this unit, please read these instructions completely.

IMPORTANT SAFETY INSTRUCTIONS

WARNING: When using electric tools, basic safety precautions should always be followed to reduce the risk of fire, electric shock and personal injury, including the following:

READ ALL INSTRUCTIONS BEFORE USING

- 1) **KEEP WORK AREA CLEAN.** Cluttered areas and benches invite accidents.
- 2) **CONSIDER WORK AREA ENVIRONMENT.** Do not expose power tools to rain. Do not use power tools in damp or wet locations. Keep work area well lit. Do not use tool in presence of flammable liquids or gases.
- 3) **GUARD AGAINST ELECTRIC SHOCK.** Prevent body contact with grounded surfaces. For example; pipes, radiators, ranges, refrigerator enclosures.
- 4) **KEEP CHILDREN AWAY.** Do not let visitors contact tool. All visitors should be kept away from work area.
- 5) **STORE IDLE TOOLS.** When not in use, tools should be stored in a dry, high or locked-up place – out of reach of children.
- 6) **DON'T FORCE TOOL.** It will do the job better and safer at the rate for which it was designed.
- 7) **USE RIGHT TOOL.** Don't force small tools or attachments to do the job of a heavy duty tool. Don't use tool for purpose not intended—for example—don't use circular saw for cutting tree limbs or logs.
- 8) **WEAR PROPER APPAREL.** No loose clothing or jewelry to get caught in moving parts. Rubber gloves and nonskid footwear are recommended when working outdoors. Wear protective hair covering to contain long hair.
- 9) **USE SAFETY GLASSES** with most tools. Also use face or dust mask in dusty environment.
- 10) **SECURE WORK.** Use clamps or a vise to hold work. It's safer than using your hand and it frees both hands to operate tool.
- 11) **DON'T OVERREACH.** Keep proper footing and balance at all times.
- 12) **MAINTAIN TOOLS WITH CARE.** Keep tools sharp at all times and clean for best and safest performance. Follow instructions for lubricating and changing accessories. Keep handles dry, clean, and free from oil and grease.
- 13) **DISCONNECT TOOLS/BATTERIES.** When not in use, before servicing, and when changing accessories, such as bits.
- 14) **REMOVE ADJUSTING KEYS AND WRENCHES.** Form a habit of checking to see that keys and adjusting wrenches are removed from tool before turning it on.
- 15) **AVOID ACCIDENTAL STARTING.** Don't carry tool with finger on switch.
- 16) **STAY ALERT.** Watch what you are doing. Use common sense. Do not operate tool when you are tired.
- 17) **CHECK DAMAGED PARTS.** Before further use of the tools, check guard or other safety devices carefully to determine that they will operate properly and perform their intended function. Check for alignment of moving parts, binding of moving parts, breakage of parts, mounting, and any other conditions that may affect its operation. A guard or other part that is damaged should be properly repaired or replaced by an authorized service center. Have defective parts replaced by an authorized service center. Do not use a defective tool.

SAVE THESE INSTRUCTIONS

FOR BATTERY CHARGER & BATTERY PACK

1) SAVE THESE INSTRUCTIONS

- This manual contains important safety and operating instructions for battery chargers EY0202, EY0001 and RE570.

- 2) Before using battery charger, read all instructions and cautionary markings on (1) battery charger, (2) battery pack.
- 3) **CAUTION** - To reduce the risk of injury, charge only battery pack as shown below.

RE570	EY970, EY9080, EY9086	Approx. 1 hour
EY0001	EY9001, EY9006	Approx. 1 hour
EY0202	EY9001, EY9080, EY9065 EY9006, EY9086	Approx. 15 min.
	EY9101, EY9180, EY9182 EY9103	Approx. 20 min.

Other types of batteries may burst causing personal injury and damage.

- 4) Do not expose charger to rain or snow.
- 5) To reduce risk of damaging the electric plug and cord, pull by plug rather than cord when disconnecting charger.
- 6) Make sure cord is located so that it will not be stepped on, tripped over, or otherwise subjected to damage or stress.
- 7) An extension cord should not be used unless absolutely necessary.

Use of improper extension cord could result in a risk of fire and electric shock. If extension cord must be used, make sure:

- that pins on plug of extension cord are the same number, size and shape as those of plug on charger.
- that extension cord is properly wired and in good electrical condition.

- that wire size is large enough for ampere rating of charger as specified below.

RECOMMENDED MINIMUM AWG SIZE OF EXTENSION CORDS FOR BATTERY CHARGERS					
AC Input Rating.	Amperes	AWG Size of Cord			
Equal to or greater than	But less than	Length of Cord. Feet			
		25	50	100	150
0	2	18	18	18	16

- 8) Do not operate charger with damaged cord or plug – replace them immediately.
- 9) Do not operate charger if it has received a sharp blow, been dropped, or otherwise damaged in any way; take it to a qualified serviceman.
- 10) Do not disassemble charger; take it to a qualified serviceman when service or repair is required. Incorrect reassembly may result in a risk of electric shock or fire.
- 11) To reduce the risk of electric shock, unplug charger from outlet before attempting any maintenance or cleaning.
- 12) The charger and battery pack are specifically designed to work together. Do not attempt to charge any other cordless tool or battery pack with this charger.
- 13) Do not attempt to charge the battery pack with any other charger.
- 14) Do not attempt to disassemble the battery pack housing.
- 15) Do not store the tool and battery pack in locations where the temperature may reach or exceed 122°F (50°C) (such as a metal tool shed, or a car in the summer), which can lead to deterioration of the storage battery.

- 16) Do not charge battery pack when the temperature is BELOW 32°F (0°C) or ABOVE 104°F (40°C). This is very important.
 - 17) Do not incinerate the battery pack. It can explode in a fire.
 - 18) Avoid dangerous environment. Do not use charger in damp or wet locations.
 - 19) The charger is designed to operate on standard household electrical power only. Do not attempt to use it on any other voltage!
 - 20) Do not abuse cord. Never carry charger by cord or yank it to disconnect from outlet. Keep cord away from heat, oil and sharp edges.
 - 21) Charge the battery pack in a well ventilated place, do not cover the charger and battery pack with a cloth, etc., while charging.
 - 22) Use of an attachment not recommended may result in a risk of fire, electric shock, or injury to persons.
 - 23) Do not short the battery pack. A battery short can cause a large current flow, over heating and burns.
 - 24) NOTE: If the supply cord of this appliance is damaged, it must only be replaced by a repair shop appointed by the manufacturer, because special purpose tools are required.
- 3) If the bit becomes jammed, immediately turn the main switch off to prevent an overload which can damage the battery pack or motor. Use reverse motion to loosen jammed bits.
 - 4) Do not operate the reversing lever when the main switch is on. The battery will discharge rapidly and damage to the unit may occur.
 - 5) During charging, the charger may become slightly warm. This is normal. Do not charge the battery for a long period.
 - 6) Use only a dry, soft cloth for wiping the unit. Do not use a damp cloth, thinner, benzine, or other volatile solvents for cleaning.
 - 7) When storing or carrying the tool, set the reversing lever to the center (switch lock) position.
 - 8) Do not strain the tool by holding the speed control trigger halfway (speed control mode) so that the motor stops.
 - 9) Do not operate the speed selector switch (LOW-HIGH) while pulling on the speed control trigger. This can cause the rechargeable battery to wear quickly or damage the internal mechanism of the motor.

ADDITIONAL SAFETY RULES

- 1) Be aware that this tool is always in an operating condition, since it does not have to be plugged into an electrical outlet.
- 2) When drilling or driving into walls, floors, etc., "live" electrical wires may be encountered. DO NOT TOUCH THE CHUCK OR ANY FRONT METAL PARTS OF THE TOOL! Hold the tool only by the plastic handle to prevent electric shock in case you drill or drive into a "live" wire.

• Changes or modifications not expressly approved by MATSUSHITA ELECTRIC WORKS, LTD. could void the user's authority to operate the equipment.

Main Unit

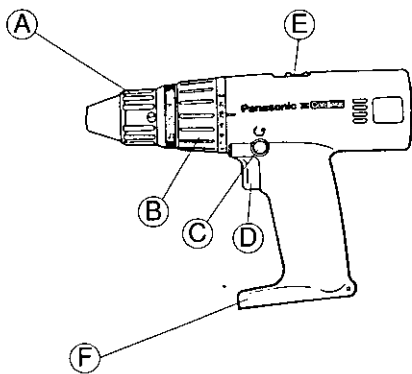

- EY6101 (12V)
- EY6100 (12V)
- EY6181 (9.6V)

Battery Pack

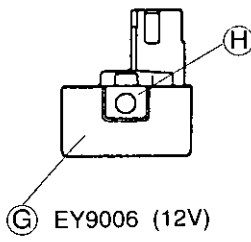
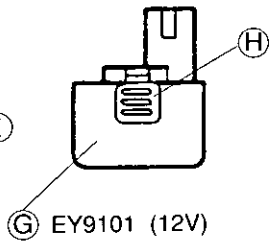
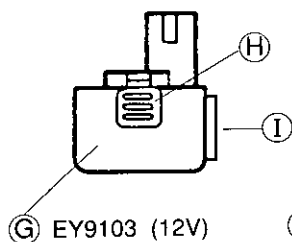

EY9182 (9.6V)

EY9086 (9.6V)

Battery Charger

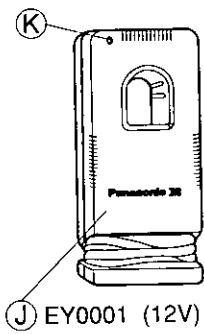
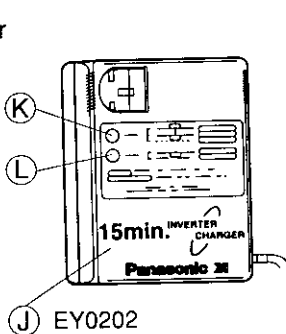

RE570 (9.6V)

Standard Accessory

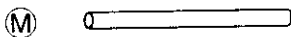

PART IDENTIFICATION

A Keyless drill chuck

Note: When attaching or removing bit, be sure to set the reversing lever to the center (switch lock) position.

This tool is equipped with a keyless drill chuck.

1) Attachment

Insert the bit and turn the lock collar clockwise (looking from the front) to tighten.

When clicking sounds stop while tightening, attachment is completed.

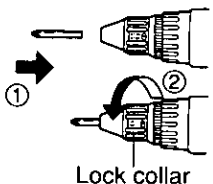

2) Removal

Turn it counterclockwise (looking from the front), then remove the bit.

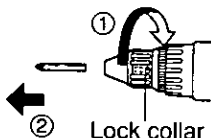

Note: If the bit cannot be removed by hand, insert the lock release rod or a similar tool into the hole located on the chuck to release the lock, and then turn the lock collar counterclockwise (viewed from the front).

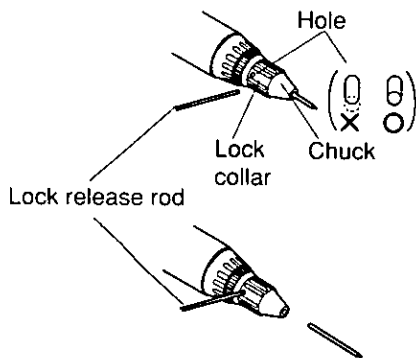

(To prevent accidental operation, remove the battery pack before trying to remove the bit.)

Note: If excessive play occurs in the chuck, ① secure the drill in place and tighten the chuck by turning ① clockwise, ② open the chuck claws by unscrewing the lock collar and ③ tighten the screw (left handed screw) with a screwdriver by turning it counterclockwise (viewed from the front).

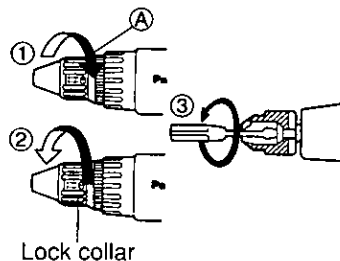

B Clutch handle (Clutch Torque Setting)

Adjust the torque out of 21 steps according to the work. There is about 0.2 Nm (2kg-cm, 1.7 in. lbs.) interval between each step.

CAUTION! Test the setting before actual operation.

※ Set the scale at this line

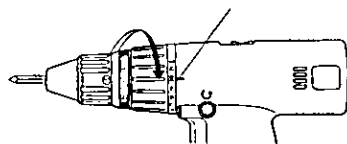



[Reference of Adjusting Torque]

Scale	Torque	Reference of work
1	Approx. 0.5 Nm, (5 kg-cm, 4.3 in. lbs.)	For driving machine screws
6	Approx. 1.5 Nm, (15 kg-cm, 13.0 in. lbs.)	For driving screws into soft materials
11	Approx. 2.5 Nm, (25 kg-cm, 21.7 in. lbs.)	For driving terminal screws
16	Approx. 3.4 Nm, (35 kg-cm, 30.4 in. lbs.)	For driving screws into hard wood
21	Approx. 4.4 Nm, (45 kg-cm, 39.0 in. lbs.)	
	High speed	For powerful driving and drilling
	Low speed	

Manual tightening function

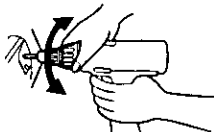
1. With the switch at off, the bit is locked in place, and the tool can be used as a manual screw-driver (up to 22.5 Nm, 230 kg-cm, 200 in. lbs.).
There will be a little play in the chuck, but this is not a malfunction.



2. This feature is handy for tightening screws that require more torque than the maximum torque of the driver (position  on the clutch), for confirming the tightness of a screw or for loosening an extremely tight screw.

C Reversing lever (Forward/ Switch lock/Reverse)

CAUTION: Set the main switch at OFF and wait until the bit has come to a complete stop before operating this lever.

1. For reverse rotation, set the lever to reverse.
Check the direction of rotation before use.
2. After use, set the lever at the center (switch lock) position.

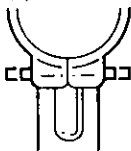

D Variable speed control trigger

1. Depress the trigger slightly to start the tool slowly.
2. The speed increases with the amount of depression of the trigger for efficient tightening of screws and drilling. The brake operates when the trigger is released and the chuck stops immediately.

Note: When the brake operates, a braking sound may be heard.
This sound indicates engagement of the bit lock.

- Do not lock the tool (motor).
This may cause damage to the unit.

E Speed selector switch

Choose a low or high speed to suit the use.

	EY6101 / EY6100	EY6181	Torque
LOW	50 ~ 350 min ⁻¹ (RPM)	50 ~ 350 min ⁻¹ (RPM)	Strong
HIGH	180 ~ 1300 min ⁻¹ (RPM)	150 ~ 1000 min ⁻¹ (RPM)	Less

CAUTION: Check the speed selector switch before use.

F Bit holder

Remove the battery pack to expose the bit storage compartment inside the handle housing.

A bit up to 50 mm, 1-31/32 long can be stored here.

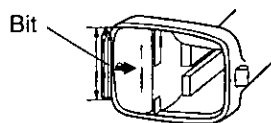

G Battery pack

ATTENTION:

The product that you have purchased contains a rechargeable battery. The battery is recyclable. At the end of its useful life, under various state and local laws, it may be illegal to dispose of this battery into the municipal waste stream. Check with your local solid waste officials for details in your area for recycling options or proper disposal.

1. Press the battery pack release buttons  on both sides and pull the pack away from the tool.
2. Charge the battery pack using the battery charger.
3. After the charging has been completed, remove the battery pack from the charger and connect it to the tool. Disconnect the charger from the power source when not in use.

Note: EY9103, EY9101 and EY9182 can not be recharged with the 1-hour battery charger EY0001 and RE570.

The Lifespan of the Storage Battery

The storage battery has a limited life. If the operation time is extremely short after a proper charge, replace the battery with a new one. If the tool is not used frequently, charge the battery at least once in 6 months to maintain battery performance.

Note: Use under extremely hot or cold conditions will reduce operation capacity on a single charge.

(H) Battery pack release button

(I) Battery capacity indicator

Reading the battery capacity indicator

1. Reading the battery capacity indicator during use

This indicator displays the remaining battery capacity for approximately 5 seconds after the trigger is switched off.

Note: The trigger must be fully depressed for minimum 2 seconds before the trigger is off in order to get an accurate reading.

Note: Each LED indicator represents 20% of battery capacity.

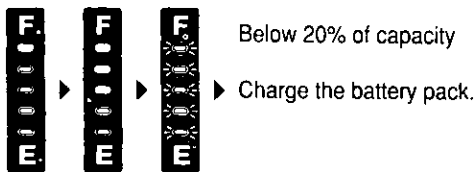

Overload indication

This indicator flashes to warn of an overload of the motor immediately before it occurs. (The display goes off when the overload condition is resolved.) Stop using the tool when this condition occurs.



2. Reading the battery capacity indicator during charging.

① At the start of charging

Part of the row of LED indicators lights up, according to the remaining battery capacity prior to charging.

② During charging

As charging progresses, additional LED indicators light up as the battery capacity increases.

③ Charging completed

Confirm by the charging lamp (K) on the charger.

- 3.

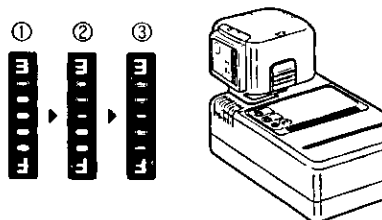

Reading the battery capacity indicator by depressing the button on the battery pack.

① Push the button.

② The indicators light up in the following sequence- battery temperature LED () → 24-hour charge LED (→24) each 0.5 seconds (during which the system diagnoses the condition of the battery.)

③ The row of LED indicator displays the remaining level of the battery capacity for approximately 5 seconds.

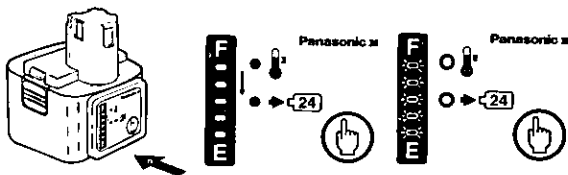

4. Troubleshooting

The following conditions may occur. However, this is not an indication the battery pack is a malfunction.

* The LED indicator might not function correctly under the following conditions;

* The battery pack has not been used for a period of time (more than two weeks).

* When the motor is locked.

* When the battery pack is used without being fully charged.

→ Use up the remaining power of the battery pack, then fully charge it.

* The lamp blinks if you pull the trigger incompletely and hold it.

→ Pull the trigger completely.

* Sometimes the lamp does not light up if the trigger is pulled completely.

→ Pull the trigger completely more than 2 seconds.

* The battery capacity indicator LED does not light up while the battery pack is being charged or being used with the main unit.

→ Use up the remaining power of the battery pack, then fully charge it.

5. When the battery temperature LED lamp lights up

This lamp lights up when the battery pack becomes too hot.

Allow the battery pack to cool down until the lamp goes off.

Note: The LED lamp will also light up in some cases when the battery pack has not been used. For example, when the ambient temperature is high (e.g. inside a car in summer), and the temperature of the battery cells inside the battery pack has become too high.

6. When the 24-hour charge LED lamp lights up

After depressing the button, when this lamp lights up, charge the battery pack for about 24 hours (until the lamp goes off) to bring the batteries up to full capacity.

J Battery charger

Note: When you charge the battery pack for the first time, or after prolonged storage, charge it for about 24 hours to bring the batteries up to full capacity.

EY0202 (Cat. No. EY0202B7658)

1. Plug the charger into the power source.
2. Insert the battery pack firmly into the charger.

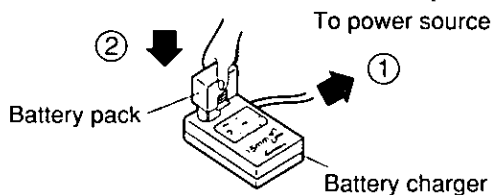

3. During charging, the charging lamp will light up.

When the charge is completed, an internal electronic switch will automatically be triggered to prevent overcharging.

• Charging will not occur if the battery pack is warm (for example, immediately after heavy-duty operation). The orange standby lamp (L) will light up until the battery becomes cool. Charging will then begin automatically.

4. When charging is completed, the charging lamp (K) will start flashing quickly.

• If a fully charged battery pack is inserted into the charger again, the charging lamp may light up and then flash quickly soon to indicate the charging is completed.

5. If the charging lamp does not turn on immediately after the charger has been plugged in, or if after standard charging time, the lamp does not go off, consult an authorized dealer for advice.
6. High capacity battery pack EY9103, EY9101 and EY9182 can be recharged by using EY0202. In this case, charging time is approximately 20 minutes.

EY0001 (Cat. No. EY0001B)

RE570 (Cat. No. EY570B7659)

1. Plug the charger into the power source.
2. Insert the battery pack firmly into the charger.

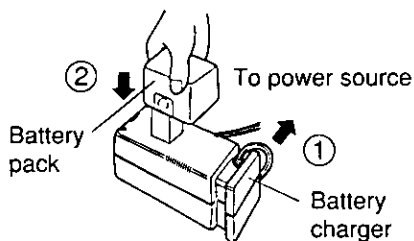

3. During charging, the charging lamp will light up. When the charge is completed, an internal electronic switch will automatically be triggered to prevent overcharging.
- Charging will not occur if the battery pack is warm (for example, immediately after heavy-duty operation).

- If the charging lamp does not light, check to determine whether the contacts are clean and the battery pack is inserted completely.
 - Give the sufficient time after use to cool down before recharging.
4. When charging is completed, the charging lamp will go out.
 - If a fully charged battery pack is placed in the charger again, the charging lamp may light up.
 5. There is a temperature rise in the battery pack immediately after use, and if charging is started, a sufficient charge may not be obtained in the standard time.
 6. If the charging lamp does not turn on immediately after the charger has been plugged in, or if after 2 hours of charging the lamp does not go off, consult an authorized dealer for advice.

Ⓚ Charging lamp

Ⓛ Standby lamp

Ⓜ Lock release rod

Lamp indications of EY0202

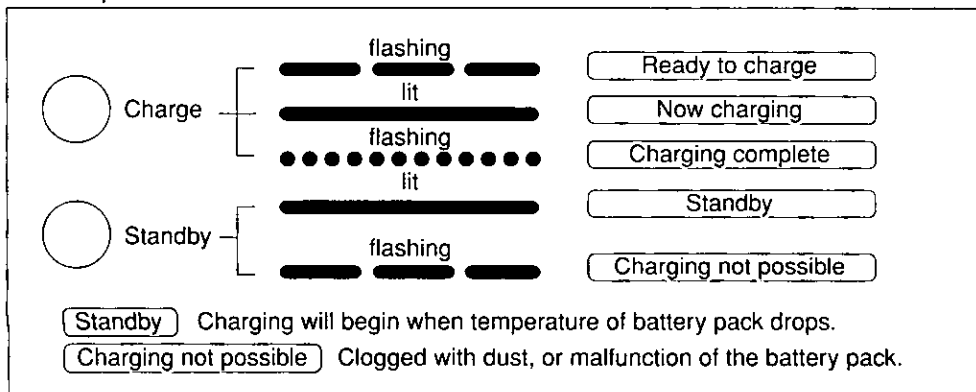

SPECIFICATIONS

MAIN UNIT

Model	EY6101
Motor	DC Motor 12V
No Load Speed : LOW : HIGH	50 ~ 350 min (r.p.m.) 180 ~ 1,300 min (r.p.m.)
Chuck Capacity	1.0 mm – 13 mm (1/8" – 1/2")
Maximum Torque : LOW : HIGH	22.6Nm (230kg-cm, 200 in. lbs.) 5.9Nm (60kg-cm, 52 in. lbs.)
Maximum Clutch Torque	4.4 Nm (45 kg-cm, 39 in. lbs.) at 21 position
Overall Length	229 mm (9-1/64")
Mass (Weight) with battery pack	2.0 kg (4.4 lbs.) with EY9103 1.95 kg (4.3 lbs.) with EY9101 1.81 kg (4.0 lbs.) with EY9006

BATTERY PACK

Model	EY9103	EY9101
Battery Type	High Capacity with Battery Capacity Indicator	High Capacity
Storage Battery	Ni-Cd Battery	
Battery Voltage	12 V DC (1.2 V X 10 cells)	

BATTERY CHARGER

Model	EY0202	
Input Voltage	120 V AC	
Applicable Battery Pack	EY9006 EY9001	EY9103 EY9101 EY9182 EY9180
Charging time	Approx. 15 min.	Approx. 20 min.
Mass (Weight)	0.66 kg (1.45 lbs.)	

EY6100	EY6181
	DC Motor 9.6V
	50 ~ 350 min ⁻¹ (r.p.m.) 150 ~ 1,000 min ⁻¹ (r.p.m.)
0.5 mm - 10 mm (1/32" - 3/8")	
19.6Nm (200kg-cm, 174 in. lbs.) 5.9Nm (60kg-cm, 52 in. lbs.)	17.6Nm (180kg-cm, 156 in. lbs.) 5.9Nm (60kg-cm, 52 in. lbs.)
218 mm (8-21/32")	
1.74 kg (3.8 lbs.) with EY9101 1.6 kg (3.5 lbs.) with EY9006	1.7 kg (3.7 lbs.) with EY9182 1.5 kg (3.3 lbs.) with EY9086

EY9006	EY9182	EY9086
Compact	High Capacity	Compact
9.6 V DC (1.2 V X 8 cells)		

EY0001	RE570
EY9006 EY9001	EY9086 EY9080 EY970
Standard 1 hour	
1.4 kg (3.1 lbs.)	1.2 kg (2.7 lbs.)

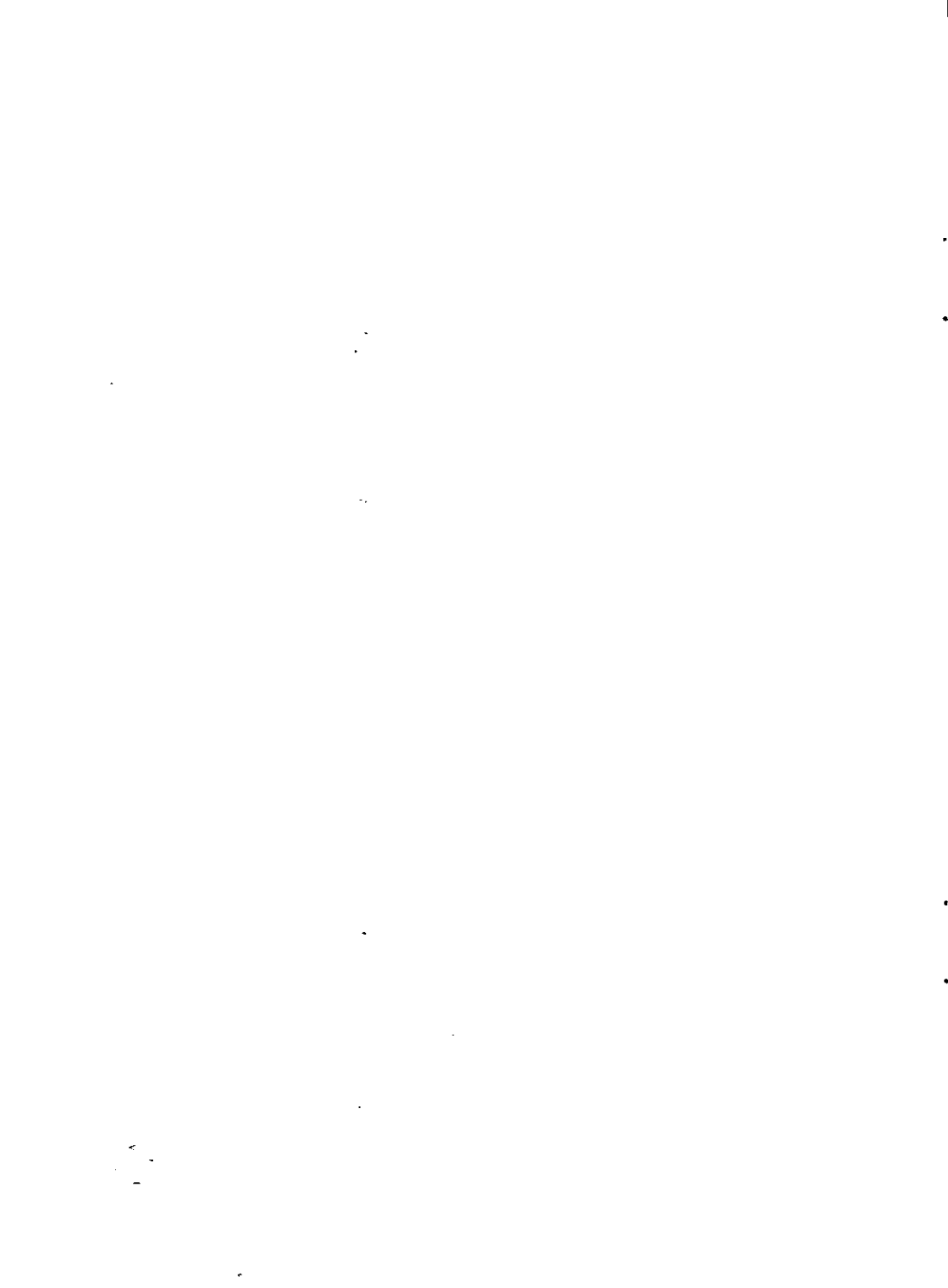

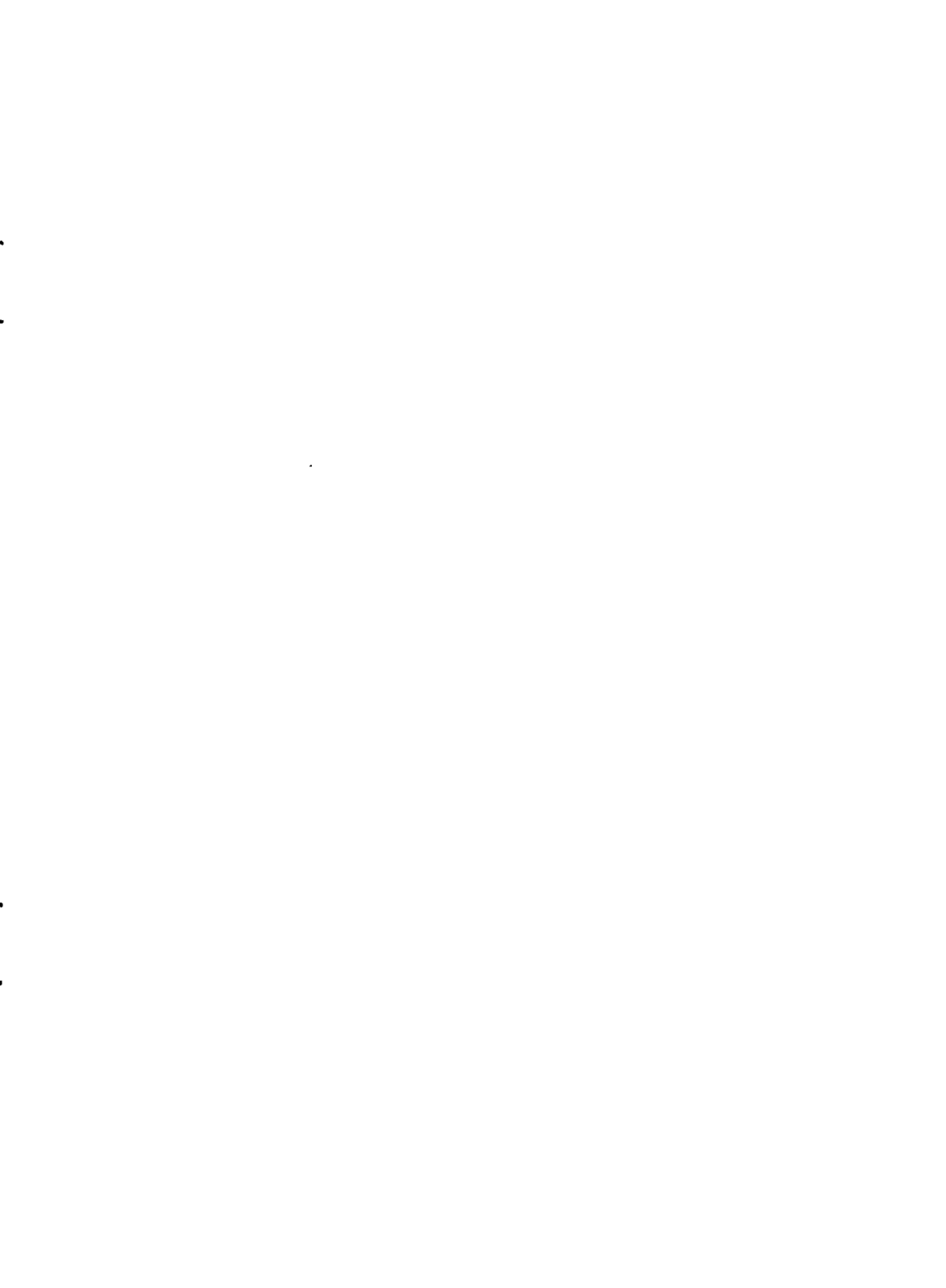

MATSUSHITA HOME & COMMERCIAL PRODUCTS COMPANY

One Panasonic Way, Secaucus, New Jersey 07094