

KETTLER

Montageanleitung für

„HAPPY PLUS PRINZESSIN“

Art. Nr. 08847-400

„HAPPY PLUS FROSCH“

Art. Nr. 08847-500

Der Umwelt zuliebe: wir drucken auf 100% Altpapier!



Abb. ähnlich



FREIZEIT MARKE KETTLER

HEINZ KETTLER GmbH & Co.KG · Postfach 1020 · D-59463 Ense-Parsit

Read these instructions carefully before assembling the product or using it for the first time. They contain important information for your safety and for the correct use and maintenance of this KETTLER product. Keep the instructions in a safe place for information or for ordering spare parts.

This KETTLER product has been designed in accordance with the latest standards of safety and subjected to constant quality monitoring. The data gained from this quality process is then incorporated in the development of our products. For this reason, we reserve the right to make changes in design and technology in order to offer our customers products of the highest standard of quality at all times. In spite of this, should you have any ground for complaint, please contact your KETTLER dealer.

For your safety

- **Attention:** An adult should always supervise playing. Only one child may use this product. Do not use the wheeled toy near slopes, steps, roads, railways, lakes and rivers, etc. Sturdy footwear should be worn at all times. We recommend wearing suitable protective clothing and a safety helmet.
- This toy is designed only for private use (no commercial or public use).
- This product is suitable for children between 2 - 5 years with a body height from 90 - 115 cm
- This child's wheeled toy conforms to the stipulated safety regulations European standard EN 71-1/-2/-3 („Safety regulations for childrens toys“; max. weight of user: 50 kg). Incorrect repairs or alterations (removal of original parts or addition of other parts etc.) may be a source of danger to the user.
- This product may only be used for the intended purpose, i.e. as a wheeled toy to be used by one (1) child. All other use is not permitted, and possibly dangerous. The manufacturer cannot be held responsible for damages caused by improper use.
- Damaged parts may endanger the user and shorten the life span of the product. Please check all parts regularly, in short intervals according to use, for possible damages and loose connections (screws, plug-in connections).
- Damaged or worn parts must be replaced straight away and the vehicle must be withdrawn from use until repaired. If required please only use original KETTLER spare parts.
- Please ensure that the vehicle will only be used for playing when assembly has been carried out correctly, and checked, by an adult.
- Although there is practically no danger to children when using the vehicle according to its intended purpose, you should always supervise play activities.
- As the product is only a toy it should not be used on public roads, because it does not conform to the road traffic regulations.
- Please bear in mind that there is always a danger of children injuring themselves (falling off, tipping over etc.) whilst using swings, climbing frames, tricycles or similar equipment.
- Do not connect this toy to any other product; because this child's wheeled toy has not been designed for higher speeds.
- Please bear in mind that children are very often not able to judge their own capabilities and certain (dangerous) situations. Also consider that a natural urge to play plus their temperament may lead children into unforeseen situations for which the manufacturer cannot be held responsible.
- Please ensure that the wheeled toy is only used in surroundings free of danger.

- This wheeled toy does not have lights. It is dangerous to use it in the dark.
- **⚠ Caution:** While assembly of the product keep off children's reach (Choking hazard - contains small parts).

Handling

- Before use always check that all screws and plug-in connections and respective safety devices fit correctly.
- Instruct children in the correct use of the product, and draw their attention to possible dangers.
- Sturdy, closed footwear must be worn when using this product.
- Please note that pedals on any wheeled toy without freewheeling appliance will turn even if the product is being pushed or is coasting.
- This wheeled toy does not have a so-called parking brake. Therefore secure the vehicle against rolling away. Do not leave children, who are not old enough to use the wheeled toy, unattended on a product.
- If this product can be adjusted please adapt it to your child's height.
- Do not transport anything on this product.
- Never use corrosive or abrasive substances to clean the toy. Never use substances which may cause pollution of the environment.
- Lubricate the bearing sleeves of the wheels and the handlebars with a few drops of oil every two or three months.
- For models with pneumatic tyres: When leaving wheeled toys with pneumatic tyres on floors containing solvents or which have been glued with such solvents (e.g. PVC) they may possibly stain it due to a chemical reaction with the natural product caoutchouc. If in doubt place something underneath the wheels. Ensure that air pressure in the tyres is correct (2,5 bar); if air pressure is too low this increases wear, and makes riding the toy more difficult!
- For models with push bars: Always ensure that the push bar fits correctly in the adaptor, and locks. Do not hang any weights on the bar! The vehicle may tip over, and your child may be hurt. The push bar is intended for adult use only, do not pass responsibility for children on to other children. For free play time take the push bar off for safety reasons.

Assembly of the toy vehicle

- The toy vehicle must be assembled carefully by an adult person. Study the assembly instructions carefully before beginning work. Assemble the vehicle in the exact sequence shown by the letters in the diagrams. This is essential for the safe function and use of the toy vehicle.
- Please note that there is **always** a danger of injury when working with tools or doing manual work. Therefore please be careful when assembling this machine.
- Ensure that your working area is free of possible sources of danger, for example don't leave any tools lying around. Always dispose packaging material in such a way that it may not cause any danger. There is always a **risk of suffocation** if children play with plastic bags!
- Bolt all the parts together loosely at first, and check that they have been assembled correctly. Tighten the locknuts by hand until resistance is felt, **then use spanner to finally tighten nuts completely against resistance (locking device)**. Then check that all screw connections have been tightened firmly. **Attention:** once locknuts have been unscrewed they no

longer function correctly (the **locking device is destroyed**), and must be replaced.

- When assembling plastic grips: The grips can be pushed onto the handlebars more easily if they are first soaked in warm water.
- For technical reasons, we reserve the right to carry out preliminary assembly work (e.g. addition of tubing plugs).

List of spare parts page 32-35

When ordering spare parts, always state the full article number, spare-partnumber, the quantity required and the S/N of the product (see handling).

Example order: Art. no. 08847-400 / spare-part no. 70121838 / 1 pieces / S/N

Please keep original packaging of this article, so that it may be used for transport at a later date, if necessary.

Goods may **only** be returned after prior arrangement and in (internal) packaging, which is safe for transportation, in the original box if possible.

It is important to provide a detailed defect description / damage report!

Important: spare part prices do not include fastening material; if fastening material (bolts, nuts, washers etc.) is required, this should be clearly stated on the order by adding the words „**with fastening material**“.

Waste Disposal

KETTLER products are recyclable. At the end of its useful life please dispose of this article correctly and safely (local refuse sites).

KETTLER (GB) Ltd. · KETTLER House, Merse Road · North Moons Moat · Redditch, Worcestershire · B 98 9 HL · Great Britain





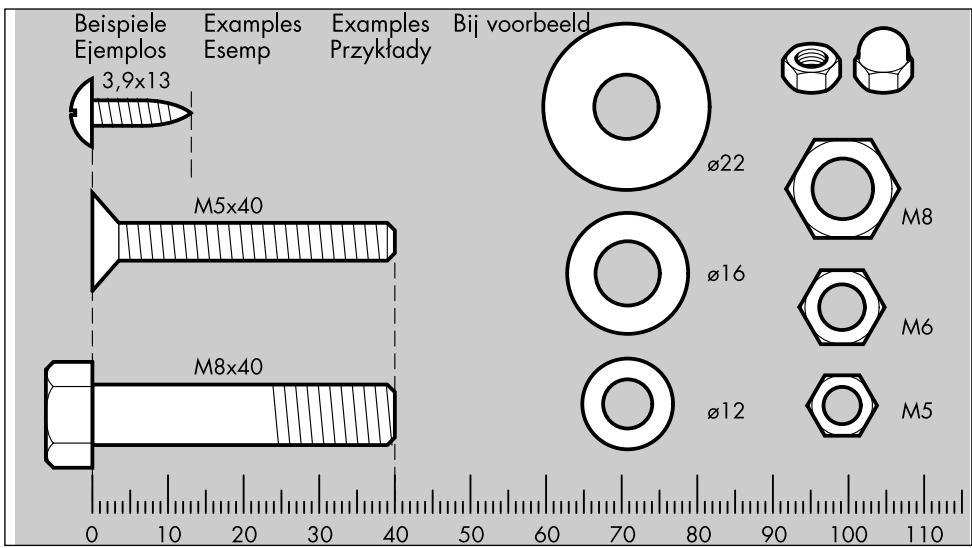

KETTLER International Inc. · 1355 London Bridge Road · Virginia Beach · Virginia VA 23453 USA



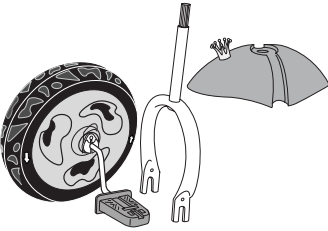
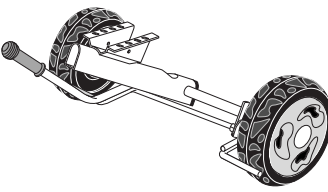
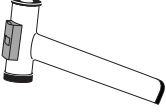
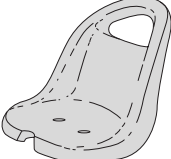
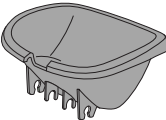
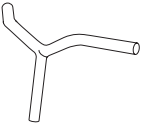







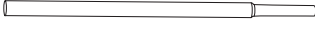

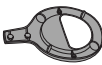

Messhilfe für Verschraubungsmaterial

- GB** Measuring help for screw connections
- F** Gabarit pour système de serrage
- E** Ayuda para la medición de los tornillos
- NL** Meethulp voor schroefmateriaal
- I** Misura per i materiali di avvitamento
- PL** Wzornik do połączeń śrubowych



Checkliste

	1 1 1	✓
	1	
	1	
	1	
	1	
	1	
	1	
	1	
	2	
	1	
	1	
	1	

		1	
		1	
		1	
		1	
		1	
		1	
	M 12	1	
	∅ 6 mm	4	
	M6 x 65mm	1	
	M6 x 25 mm	1	
	M5 x 30 mm	2	
	4,8 x 16 mm	1	
	4,2 x 16 mm	5	
	M5 x 10 mm	2	
		1	
		1	

1a

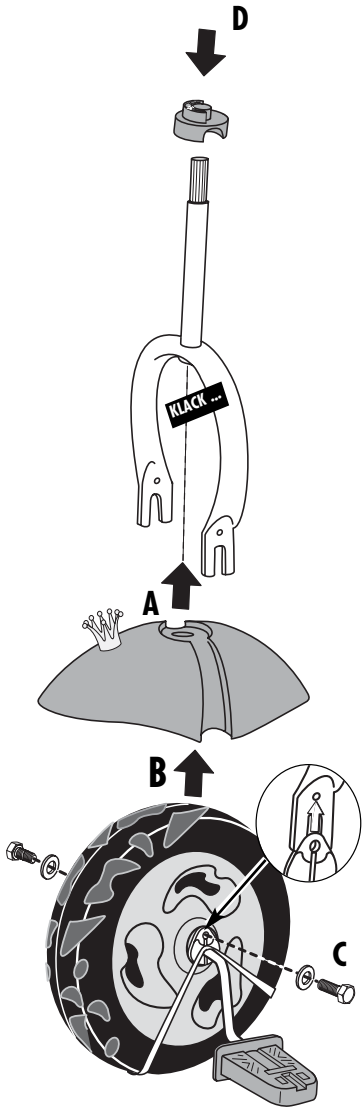

M 5 x 10 mm

1b

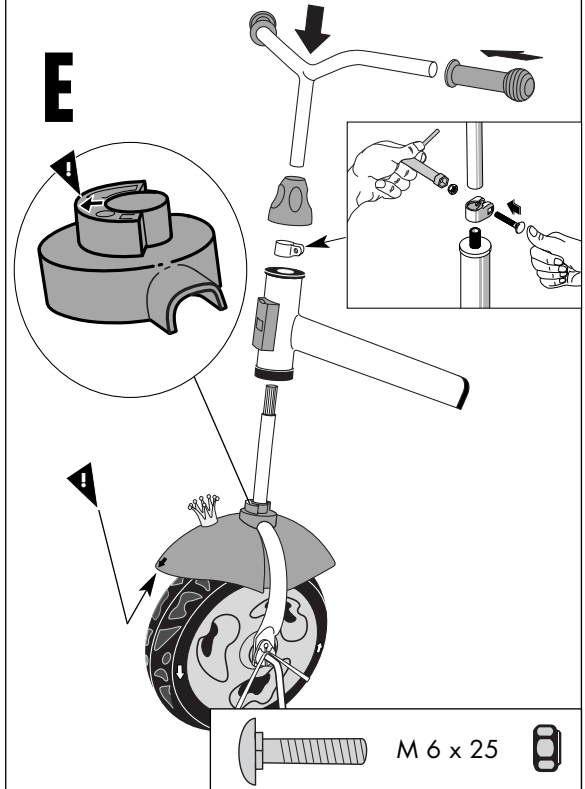

1c

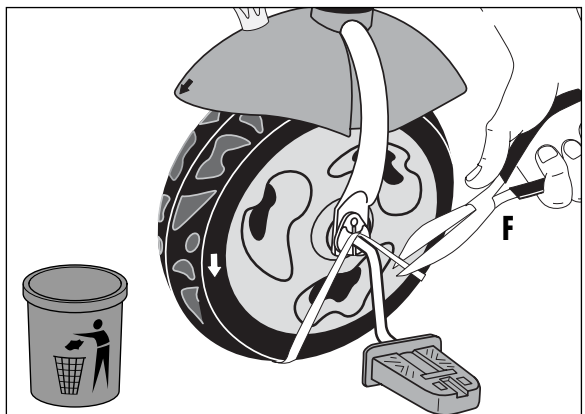

2

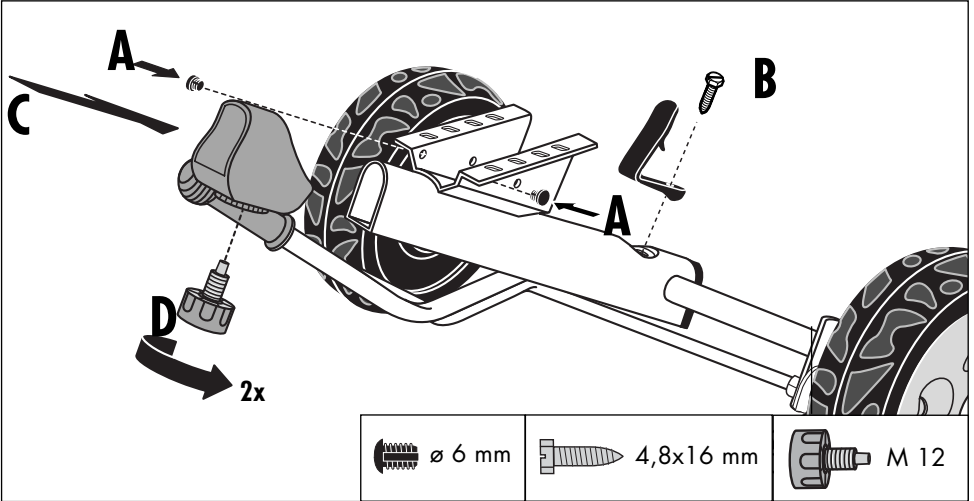

3

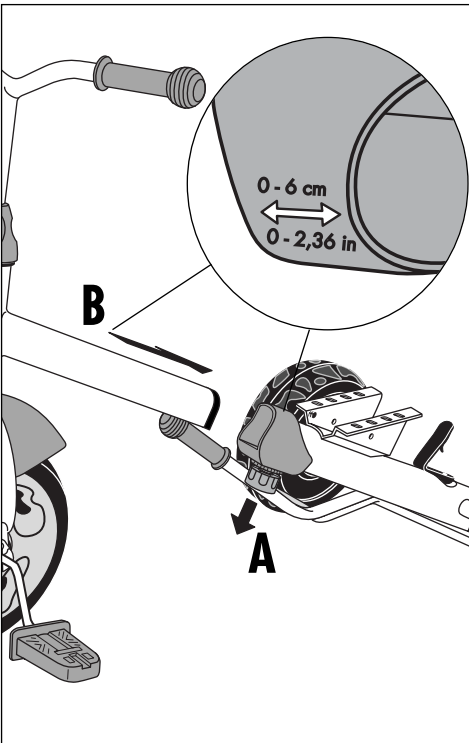

4

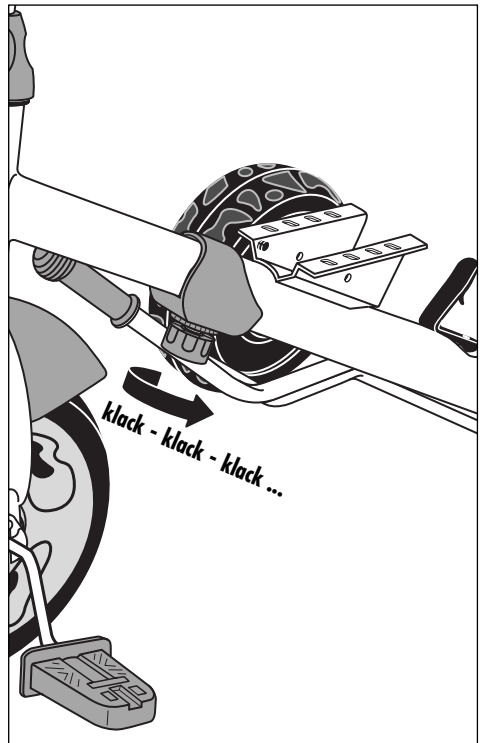

5a

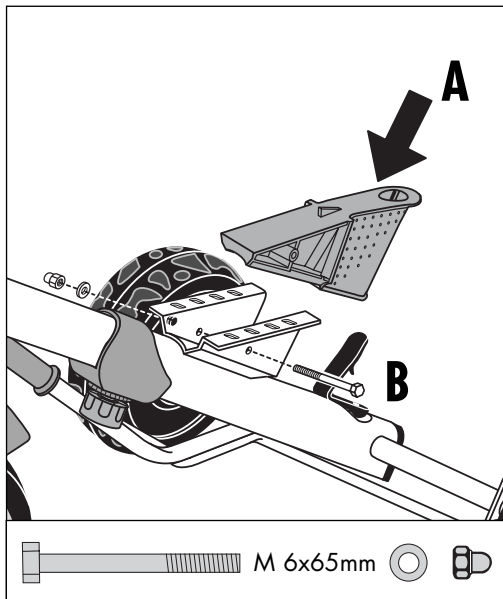

5b

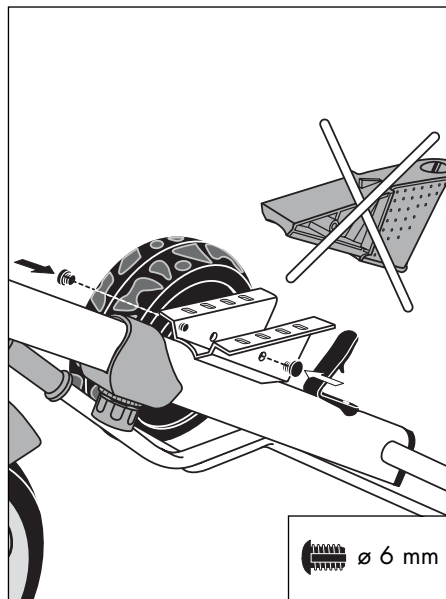

6

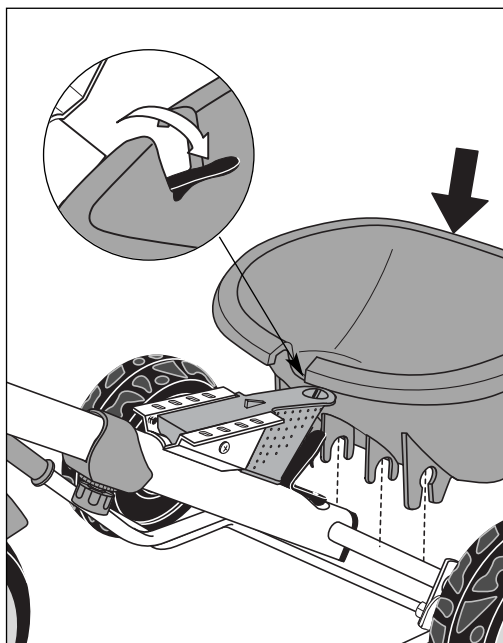

7

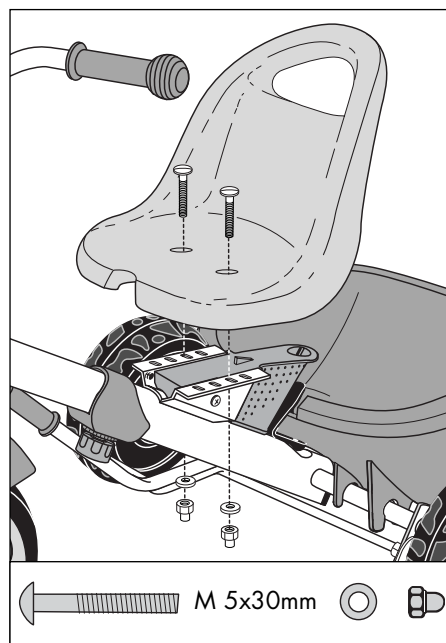

8

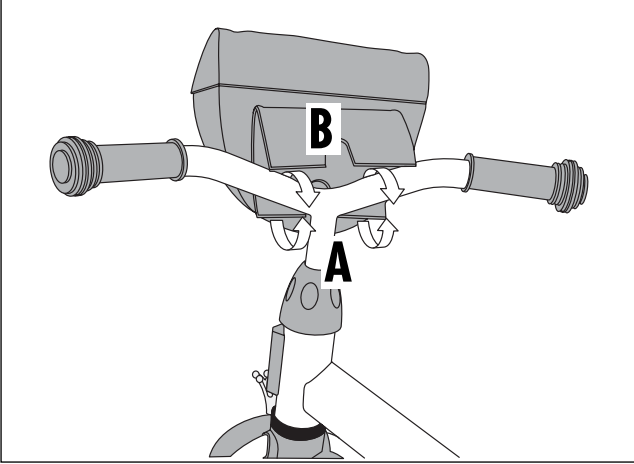

9

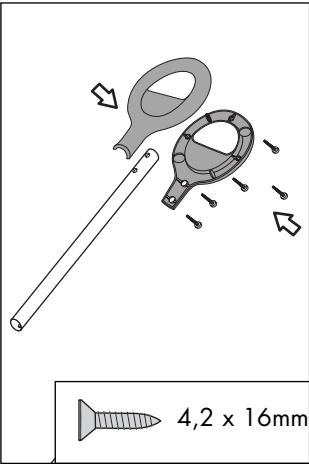

10

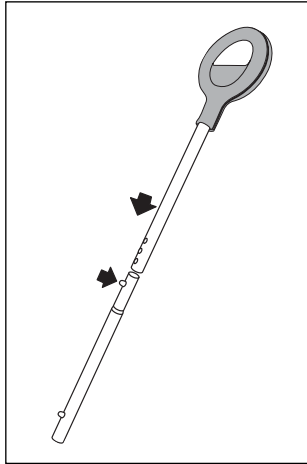

11a

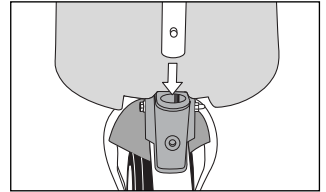

11 b

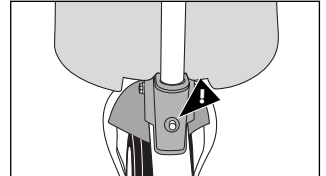

Handhabungshinweise

GB Handling

F Indications relatives à la manipulation

NL Bedieningsinstructies

PL Wskazówki obsługowe

E Instrucciones de manejo

I Avvertenze per il maneggio

1

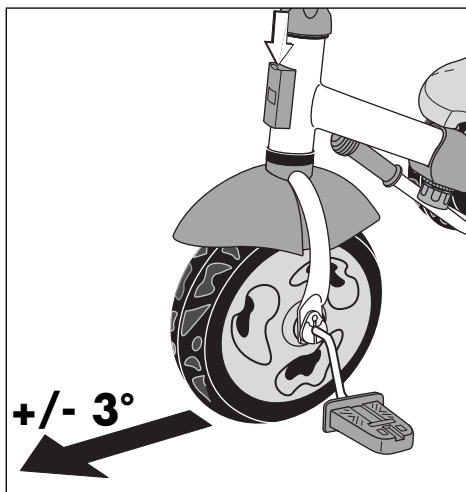

2

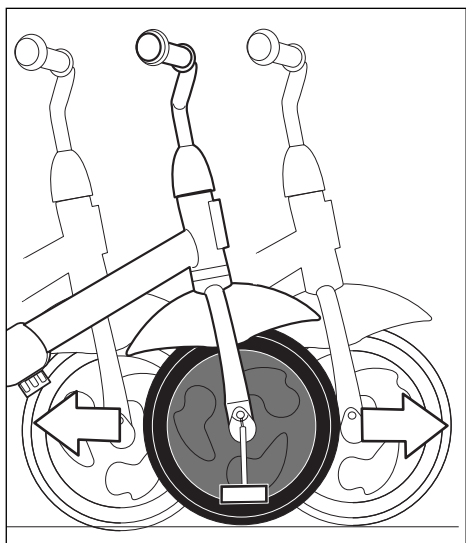

1a

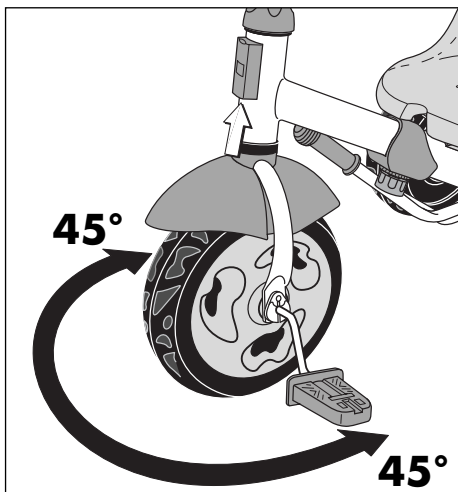

2a

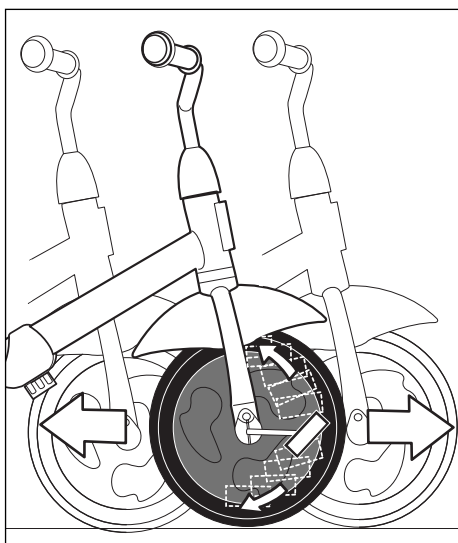

Handhabungshinweise

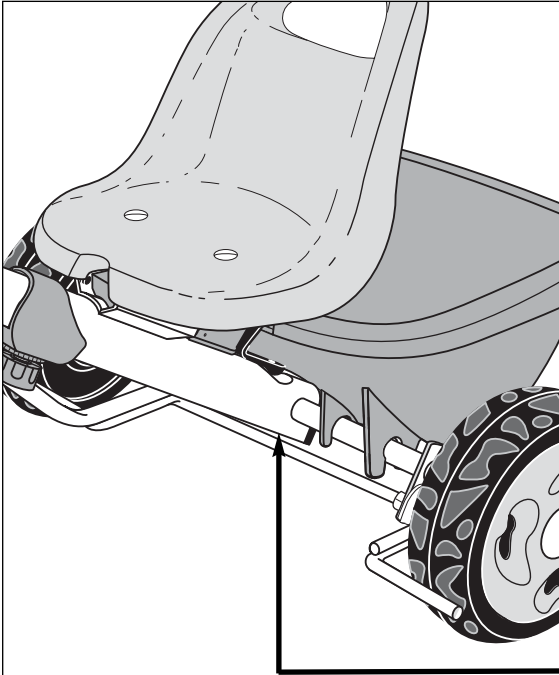

- Ⓓ Beispiel Typenschild - Seriennummer
- ⒼⒷ Example Type label - Serial number
- Ⓕ Example Plaque signalétique - Numéro de serie
- ⒼⒹ Bij voorbeeld Typeplaatje - Seriennummer
- Ⓔ Ejemplo Placa identificativa - Número de serie
- Ⓘ Esempio Targhetta tecnica - Numero di serie
- Ⓟ Przykłady Tabliczka identyfikacyjna - Numer serii



FREIZEIT MARKE KETTLER
HEINZ KETTNER GmbH & Co. KG
D-59469 Ense - Parsit

Artikel.-Nr.: 07044-000

▶ 1-344 O-1805
geprüft nach prEN 14468 -1, -2
Klasse C, Typ 4
Made in Germany

Ersatzteilzeichnung „HAPPY PLUS PRINZESSIN“ Art. Nr. 08847-400

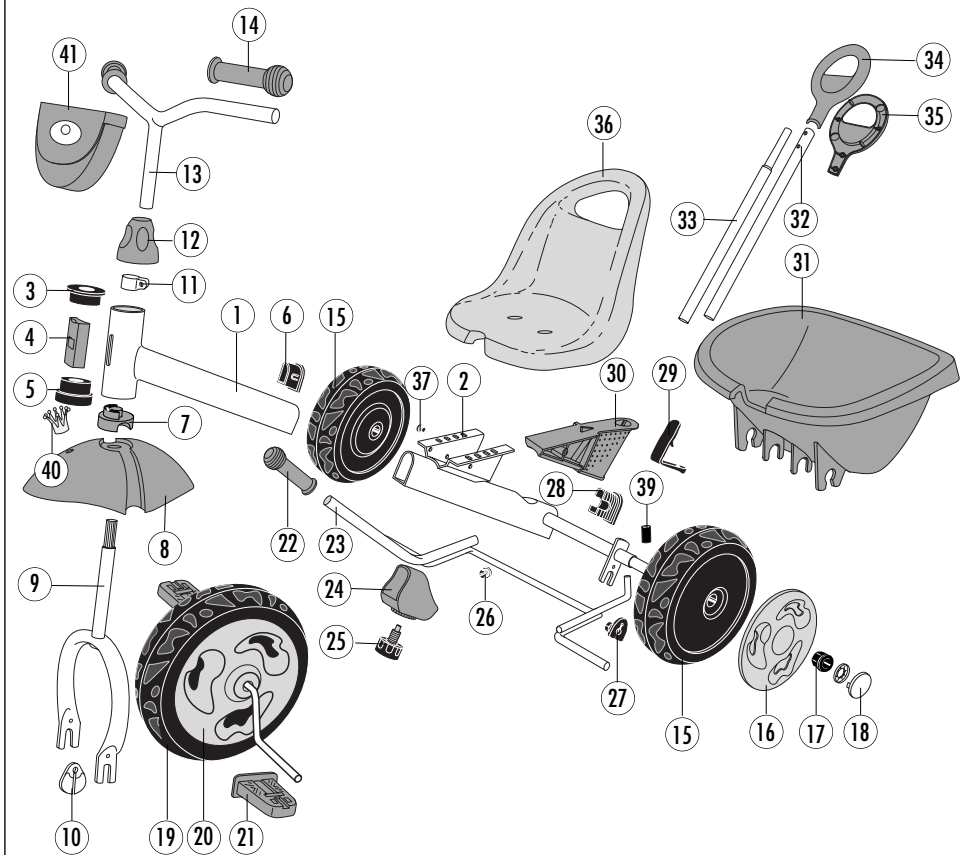

Ersatzteilstückliste „HAPPY PLUS PRINZESSIN“ Art. Nr. 08847-400

Pos.	Bezeichnung	Stk	Ersatzteilnr.
1	Rahmenvorderbau (kpl. m. Riegel, Lenkkopfbuchse, Riegelschieber u. Führungsbuchsen)	1	91611357
2	Rahmenhinterbau (kpl. mit Stopfen und Bef.-Mat. für Räder und Sandschale)	1	91611358
3	Lenkkopfbuchse (2046)	1	70122051
4	Riegelschieber ((2970)	1	70121836
5	Führungsbuchse für ø42mm (2969)	1	70121560
6	Führungsbuchse für Verstellung (2995)	1	70128425
7	Lenkansschlag (3536)	1	70121887
8	Radschutz (4855)	1	70121839
9	Radgabel	1	91620358
10	Tretlagerbuchse	2	10116038
11	Klemmschelle (kpl. mit Schraube und Mutter)	1	97201280
12	Abdeckung Lenkkopfbuchse (3497)	1	70121889
13	Lenker	1	91650346
14	Griff	2	10111037
15	Laufrad	2	15170103
16	Blende für Laufrad	2	70121869
17	Sechskantbuchse	4	70121470
18	Stopfen für Blende (2042)	2	70121758
19	Vorderrad (kpl. mit Tretkurbel und Tretlagerbuchsen)	1	15170081
20	Blende für Vorderrad (3491)	2	70121883
21	Pedal mit Bef.-Mat. (1848)	2	70121886
22	Bremsgriff für ø8mm (2717)	1	70121838
23	Bremse (kpl. mit Bremsgriff und Schutzkappen für ø8mm)	1	91640093
24	Sicherungskappe (3498)	1	70121888
25	Griffschraube M12	1	91670120
26	Stopfen ø18mm	1	10100006
27	Achslager	2	10116029
28	Stopfen (3535)	1	70121432
29	Rasthebel für Sandschale (3533)	1	70121890
30	Schubstangenadapter (3493)	1	70121891
31	Sandschale (3532)	1	70121837
32	Schubstangen-Oberrohr	1	97100399
33	Schubstangen-Unterrohr mit Stativfeder	1	97100400
34	Griff-Oberteil (3378)	1	70121884
35	Griff-Unterteil (3379)	1	70121885
36	Blassitz (3534)	1	70120208
37	Stopfen Ø8x6,5x12 mm	4	10100169
38	Riegel (kpl., o. Abb.)(2968)	1	91640021
39	Tauchkappe	1	10101105
40	Krone (4901)	1	70121834
41	Lenkertasche	1	19100000
42	Schraubenbeutel (o. Abb.)	1	91680472

Ersatzteilzeichnung „HAPPY PLUS FROSCH“ Art. Nr. 08847-500

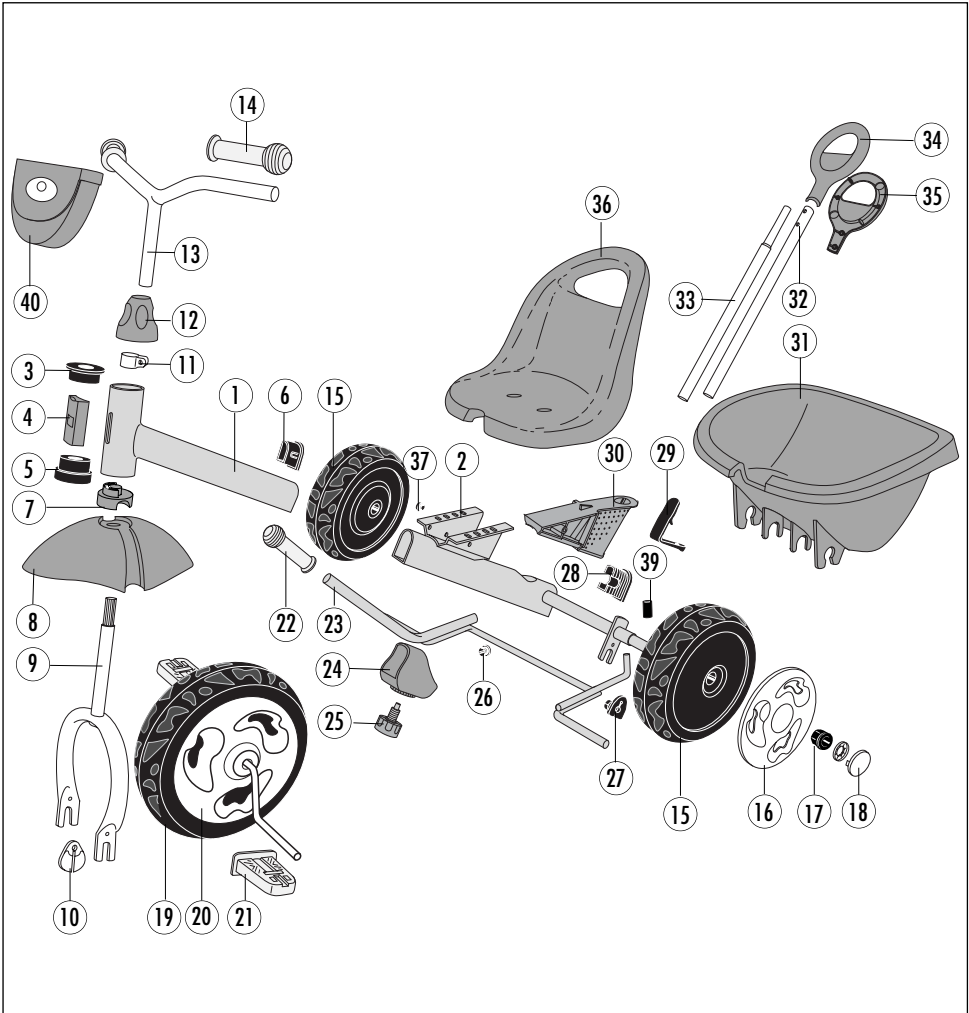

Ersatzteilstückliste „HAPPY PLUS FROSCH“ Art. Nr. 08847-500

Pos.	Bezeichnung	Stk	Ersatzteilnr.
1	Rahmenvorderbau (kpl. m. Riegel, Lenkkopfbuchse, Riegelschieber u. Führungsbuchsen)	1	91611367
2	Rahmenhinterbau (kpl. mit Stopfen und Bef.-Mat. für Räder und Sandschale)	1	91611368
3	Lenkkopfbuchse (2046)	1	70122051
4	Riegelschieber ((2970)	1	70121809
5	Führungsbuchse für ø42mm (2969)	1	70121560
6	Führungsbuchse für Verstellung (2995)	1	70128425
7	Lenkansschlag (3536)	1	70121808
8	Radschutz (4031)	1	70121830
9	Radgabel	1	91620358
10	Tretlagerbuchse	2	10116039
11	Klemmschelle (kpl. mit Schraube und Mutter)	1	97201280
12	Abdeckung Lenkkopfbuchse (3497)	1	70121799
13	Lenker	1	91650347
14	Griff	2	10111036
15	Laufrad	2	15170104
16	Blende für Laufrad	2	70121879
17	Sechskantbuchse	4	70121470
18	Stopfen für Blende (2042)	2	70121831
19	Vorderrad (kpl. mit Tretkurbel und Tretlagerbuchsen)	1	15170081
20	Blende für Vorderrad (3491)	2	70121868
21	Pedal mit Bef.-Mat. (1848)	2	70121759
22	Bremssgriff für ø8mm (2717)	1	70121549
23	Bremse (kpl. mit Bremssgriff und Schutzkappen für ø8mm)	1	91640095
24	Sicherungskappe (3498)	1	70121806
25	Griffschraube M12	1	91670124
26	Stopfen ø18mm	1	10100006
27	Achslager	2	10116029
28	Stopfen (3535)	1	70121432
29	Rasthebel für Sandschale (3533)	1	70121768
30	Schubstangenadapter (3493)	1	70121769
31	Sandschale (3532)	1	70121832
32	Schubstangen-Oberrohr	1	97100399
33	Schubstangen-Unterrohr mit Stativfeder	1	97100400
34	Griff-Oberteil (3378)	1	70121797
35	Griff-Unterteil (3379)	1	70121798
36	Blassitz (3534)	1	70120234
37	Stopfen Ø8x6,5x12 mm	4	10100169
38	Riegel (kpl., o. Abb.) (2968)	1	91640021
39	Tauchkappe	1	10101105
40	Lenkertasche	1	19100002
41	Schraubenbeutel (o. Abb.)	1	91680477



FREIZEIT MARKE KETTLER

