

HONDA F200

OWNER'S MANUAL

This manual covers operation and maintenance of the F200 tiller. All information in this publication is based on the latest product information available at the time of approval for printing. Honda Motor Co., Ltd. reserves the right to make changes at any time without notice and without incurring any obligation. The manual should be considered a permanent part of the tiller and remain with the tiller when sold. Read the manual carefully. Pay special attention to statements preceded by the following words:

 **WARNING**

Indicates a strong possibility of severe personal injury or loss of life if instructions are not followed.

CAUTION:

Indicates a possibility of personal injury or equipment damage if instructions are not followed.

NOTE:

Gives helpful information.

Thank you for purchasing a Honda Tiller.

If a problem should arise, or if you have any questions about the tiller, consult an authorized Honda dealer.

 **WARNING**

The Honda tiller is designed to give safe and dependable service if operated according to instructions. Read and understand the Owner's Manual before operating the tiller. Failure to do so could result in personal injury or equipment damage.

No part of this publication may be reproduced without written permission.

© Honda Motor Co., Ltd., 1980

IMPORTANT NOTICE

This tiller is not equipped with a spark arrester. Operation on forest, bush or grass covered land may be illegal in some states. Check local laws and regulations before operation.

CONTENTS

SAFE OPERATION	4
COMPONENT IDENTIFICATION	5
OPERATION	7
MAINTENANCE	17
TRANSPORTING/STORAGE	24
SPECIFICATIONS	27

SAFE OPERATION

WARNING *To ensure safe operation*

- Never permit anyone to operate the tiller without proper instruction.
- Know how to stop the tiller quickly and understand the operation of all the controls – **READ THIS OWNER'S MANUAL CAREFULLY.**
- Keep children and pets at a safe distance when tilling.
- Clear the area to be tilled by picking up any stones, wire, glass, large sticks, metal, etc.
- Always stop the engine before cleaning the tines or making adjustments.
- Never operate the tiller without the recoil starter.
- Stop the engine whenever you leave the tiller. Never allow it to idle unattended.
- If you strike an object while tilling, stop the engine and check the tiller for damage.
- When tilling on an incline, keep the fuel tank less than half full to minimize fuel spillage.
- Make sure that all fasteners are properly secured.
- Wear suitable clothing and shoes while using the tiller.
- Whenever carrying the tiller, make sure to stop the engine; or the rotor may turn even if the clutch is disengaged.

COMPONENT IDENTIFICATION

1. Fuel tank cap
2. Fuel valve
3. Air cleaner
4. Muffler
5. Throttle lever
6. Front wheel
7. Engine switch

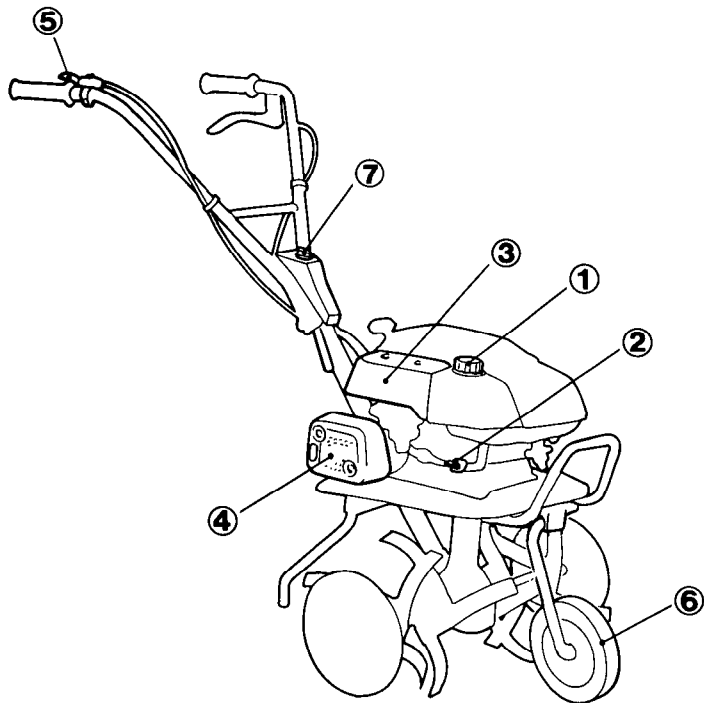

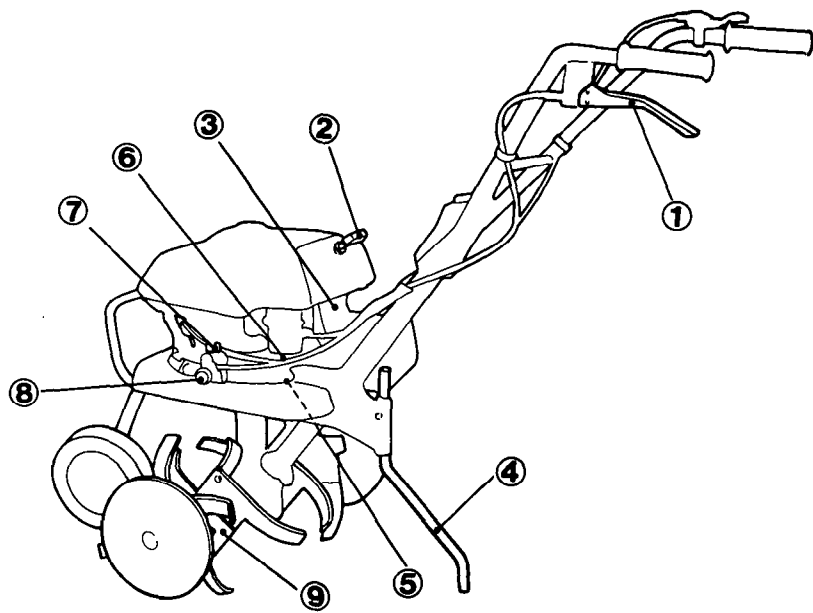

1. Clutch lever
2. Recoil starter
3. Spark plug
4. Drag bar
5. Mission oil level check bolt
6. Mission oil filler cap
7. Engine oil filler cap
8. Engine oil drain bolt
9. Rotor

OPERATION

Pre-Operation Check

Always check the following before using the tiller:

- (A) Engine oil level
- (B) Transmission oil level.
- (C) Air cleaner condition.
- (D) Fuel level.

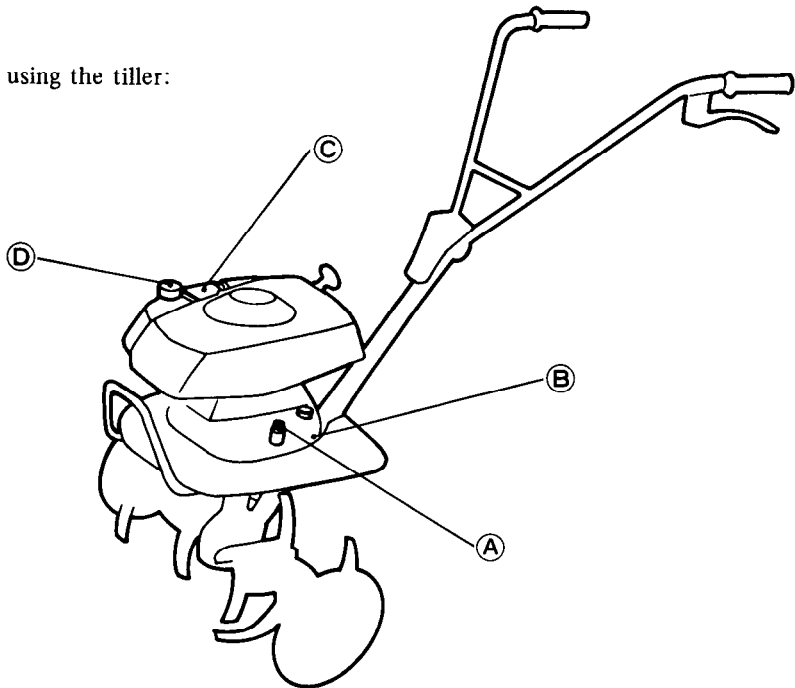

A. ENGINE OIL LEVEL

CAUTION: *Engine oil is a major factor affecting engine performance and service life. Non-detergent or vegetable oils are not recommended.*

Oil Recommendation

Use Honda 4-stroke oil or an equivalent.

Use only high detergent, premium quality motor oil certified to meet or exceed US automobile manufacturer's requirements for Service Classification SE, in the engine and transission.

Motor oils intended for Service SE will show this designation on the container. The regular use of special oil additives is unnecessary and will only increase operating expenses.

CAUTION: *Engine oil quality is a major factor affecting the performance and service life of the engine. Nondetergent or vegetable oils are not recommended.*

Recommended oil viscosity

SAE 10W-40

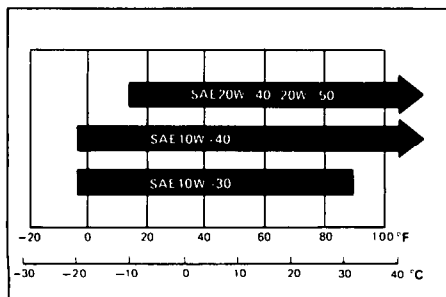

Other viscosities shown in the chart below may be used when the average temperature in your area is within the indicated range.

With the tiller on a level surface, remove the oil filler cap and check the oil level.

If the level is low, fill to the upper level with the recommended oil.

CAUTION: *Insufficient oil will cause overheating and subsequent wear.*

- (1) Oil filler hole
- (2) Oil filler cap

- (3) Upper limit
- (4) Lower limit

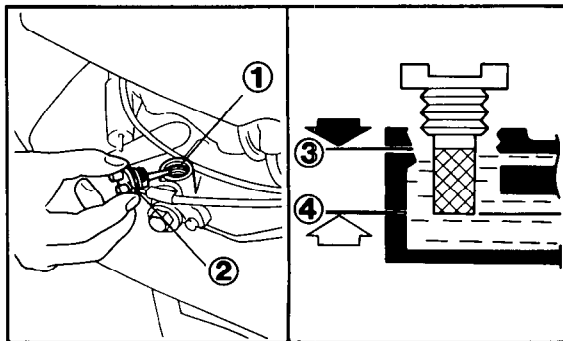

B. TRANSMISSION OIL LEVEL

With the tiller on a level surface remove the oil level check bolt and check if the oil flows out of the bolt hole. If the oil level is low, refill with the recommended oil till it flows out of the bolt hole.

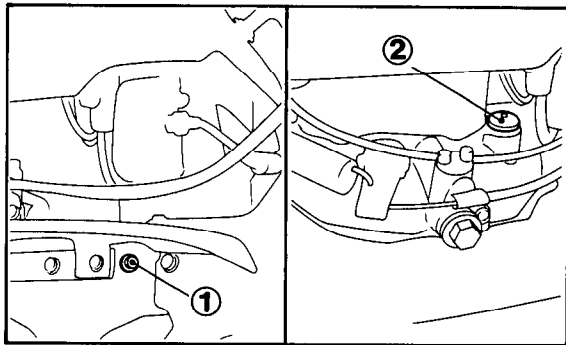

(1) Oil level check bolt (2) Oil filler cap

C. AIR CLEANER CONDITION

Remove the cover and inspect the elements, clean them if necessary (see p. 19).

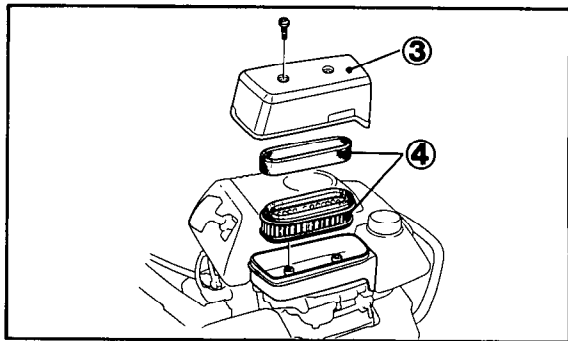

(3) Air cleaner cover (4) Air cleaner elements

E. FUEL

Use any automotive gasoline with a research octane of 91 or higher or a pump octane ($\frac{R+M}{2}$) of 86 or higher.

WARNING

- *Gasoline is extremely flammable and explosive under certain conditions. Refuel in a well ventilated area with the engine stopped. Do not smoke or allow flames or sparks in the area where the tiller is refueled or stored.*
- *Never fill the tank above the level.*

CAUTION: *Gasoline substitutes are not recommended, they may be harmful to the fuel system components.*

Fuel tank capacity: 0.85 ℓ (1.80 US pt).

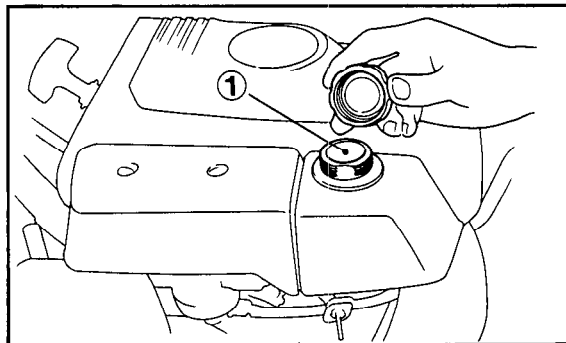

(1) Fuel filler hole

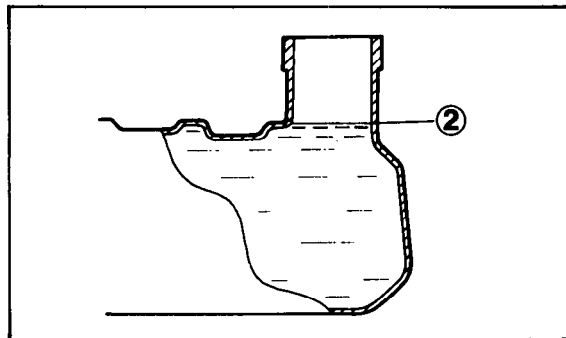

(2) Upper level

Starting the Engine

WARNING

- *Exhaust contains poisonous carbon monoxide gas. Never run the engine in a green house or confined area. Be sure to provide adequate ventilation.*
- *The muffler becomes very hot during operation, and it remains hot for a time after the engine is turned off. Avoid touching a hot muffler.*
- *Keep away from rotating parts while the engine is running.*

1. Turn the fuel valve ON.

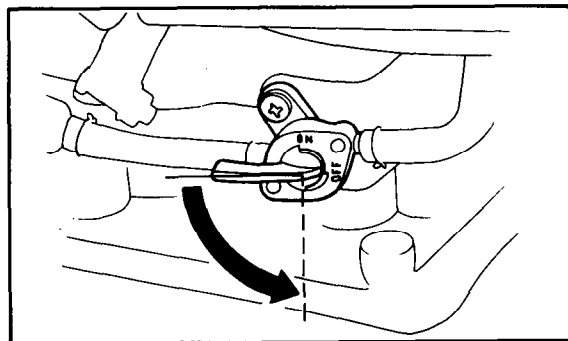

(1) Fuel valve (2) ON

2. Turn the engine switch to ON.

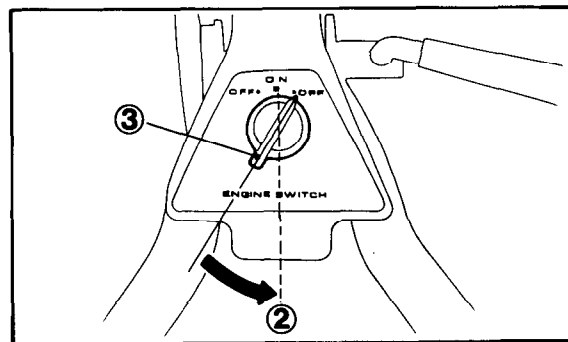

(3) Engine switch

3. Move the choke lever to **CLOSE**, when the outside temperature is low or the engine is cold.

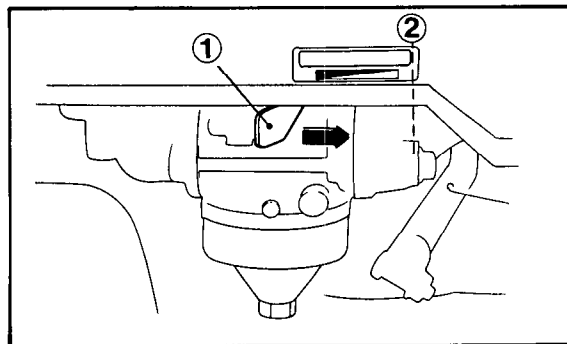

(1) Choke lever

(2) CLOSE

4. Move the throttle lever about 30 degrees from the extreme right (idle position).

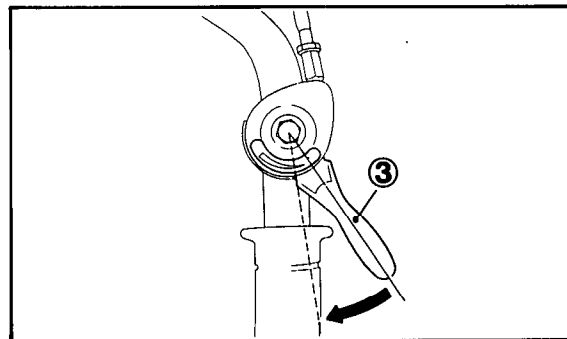

(3) Throttle lever

NOTE: The clutch is engaged by pulling in the clutch lever and disengaged by releasing the lever.

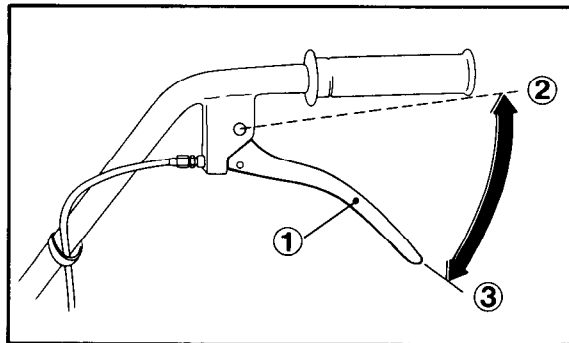

(1) Clutch lever

(2) Engaged

(3) Disengaged

5. Make sure the clutch is disengaged, then pull the starter rope briskly to start the engine.

CAUTION:

- *Be sure the clutch is disengaged to prevent sudden uncontrolled movement when the engine starts.*
- *Release the starter rope gradually. Allowing it to snap back can damage the mechanism.*

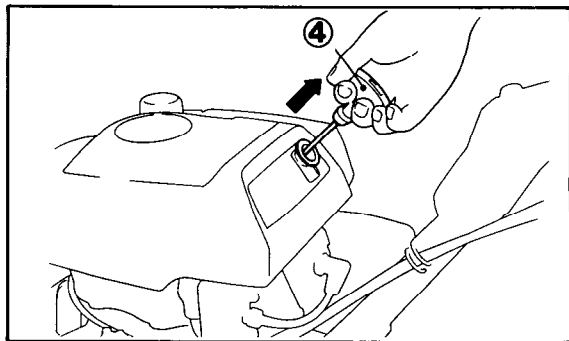

(4) Starter

6. Allow the engine to warm up, then move the choke lever to OPEN.

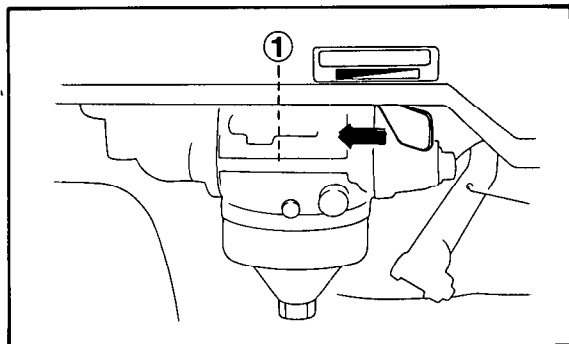

(1) OPEN

7. Move the throttle lever to the left as desired to increase engine speed.

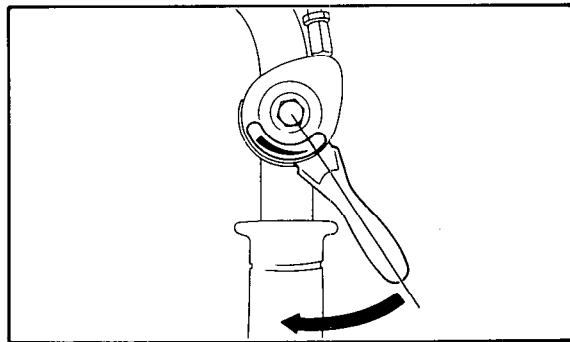

Stopping the Engine

1. Disengage the clutch (release the lever).
2. Move the throttle lever to the extreme right.

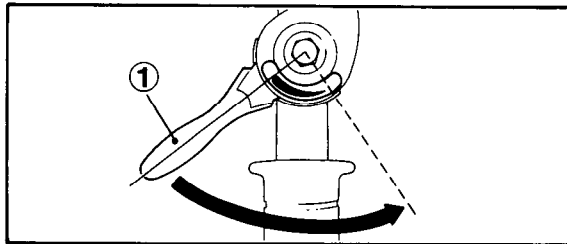

(1) Throttle lever

3. Turn the engine switch OFF to stop the engine.

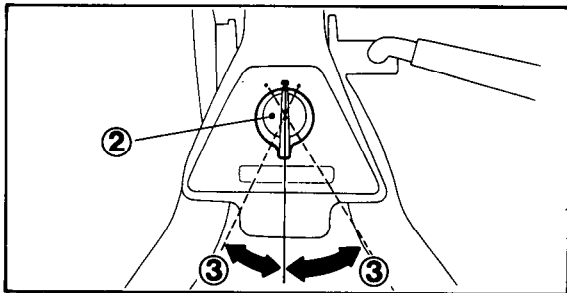

(2) Engine switch (3) OFF

4. Turn the fuel valve OFF.

NOTE: To stop the engine in an emergency, disengage the clutch and turn the engine switch OFF.

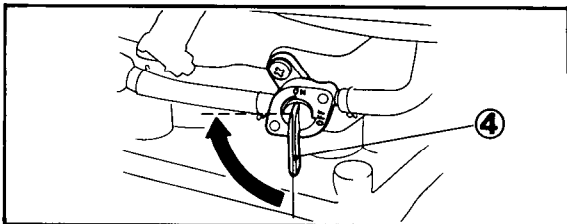

(4) Fuel valve

Handlebar Height Adjustment

CAUTION: Before adjusting the handlebar, place the tiller on firm level ground to prevent the handle from falling accidentally.

To adjust the handlebar height, loosen the adjuster, select the appropriate holes and tighten the adjuster.

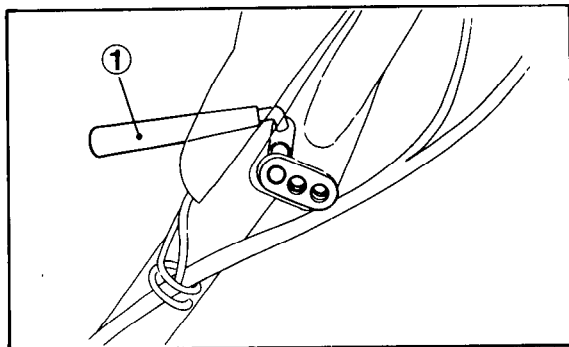

(1) Handle height adjuster

Tilling depth adjustment

The tilling depth adjustment can be made by removing retainer and sliding drag bar up or down as necessary.

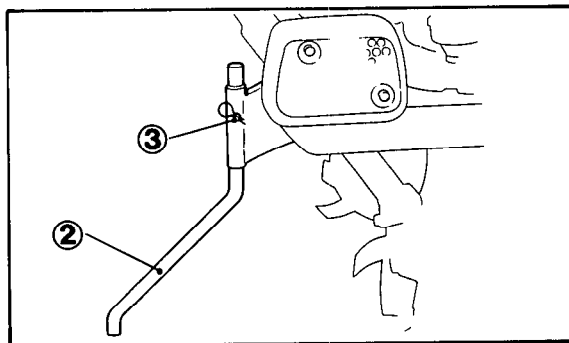

(2) Drag bar (3) Retainer

MAINTENANCE

WARNING Shut off the engine before performing any maintenance.

CAUTION: To maintain the safety and reliability of your HONDA tiller do not modify the tiller. Use only genuine HONDA parts or their equivalent when servicing or repairing.

MAINTENANCE GUIDE

Periodic inspection and adjustment of the Honda Tiller is essential if a high level of performance is to be maintained. Regular maintenance will also insure the longest possible life of your Honda tiller.

- Performed by owner.
- Should be performed by an authorized Honda dealer unless the owner has the proper tools and is mechanically proficient. See the Honda Shop Manual.
- * Service the air cleaner more frequently as required.

Regular Service Period Perform at every indicated month or operating hour interval, whichever comes first.		Before operation	Initial 20 hours operation	First month or 20 hours operation	Every 3 months or 50 hours operation	Every 6 months or 100 hours operation	Every one year or 300 hours operation
Item							
Engine oil	Check level	○					
Engine oil	Change		○			○	
Transmission oil	Check level	○					
Air cleaner element	Check	○					
Air cleaner element	Clean			*○			
Clutch cable	Adjust				○		
Throttle cable	Adjust						○
Spark plug	Clean					○	
Clutch shoe	Change						●
Ignition timing	Adjust						●
Tappet clearance	Adjust						●
Combustion chamber	Clean (Inc. valve lapping)						●
Fuel line	Check (Replace, if necessary)						●
Fuel strainer	Check (Replace, if necessary)						●
Fuel tank	Clean						●

Engine Oil Change

NOTE: Change the oil when the engine is warm to assure rapid and complete draining.

1. Remove the oil drain bolt and the filler cap to drain.
2. Reinstall the drain bolt and fill the crankcase to the upper level with the recommended oil.
3. Reinstall and tighten the filler cap.

Oil capacity: 0.45 ℓ (0.95 US pt)

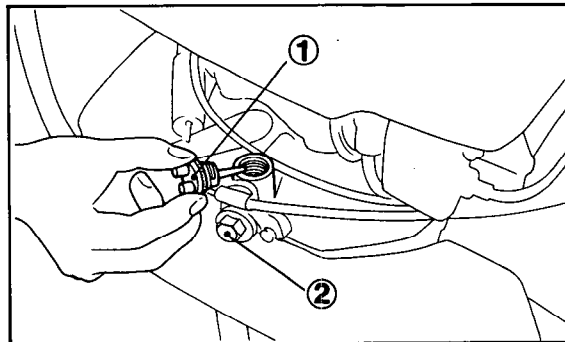

(1) Oil filler cap (2) Oil drain bolt

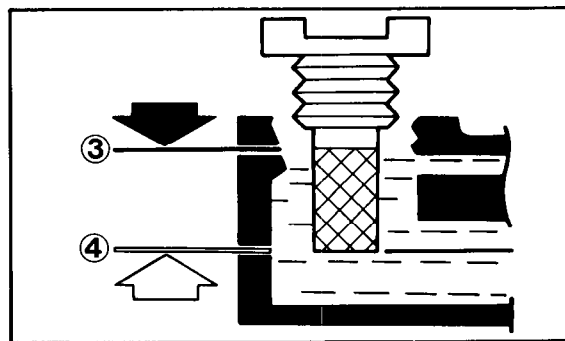

(3) Upper level (4) Lower level

Air Cleaner Service

A dirty air cleaner will restrict air flow to the carburetor.

To prevent carburetor malfunction, service the air cleaner frequently.

1. Remove the screws and air cleaner cover.
Remove the elements and separate them.
2. Wash the foam element in liquid detergent and water and flush until water is clear. Dry it thoroughly by applying compressed air. After drying, soak in oil and squeeze out the excess.
3. Remove dust from paper element by applying compressed air or tapping the case lightly. If the paper element is excessively dirty, replace or wash it in liquid detergent and water and flush until water is clear. Dry it thoroughly by applying compressed air before installing.

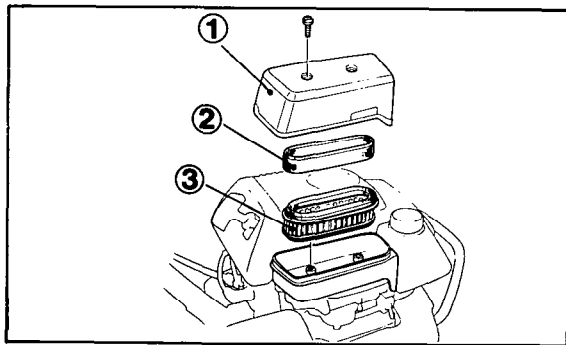

(1) Air cleaner cover (2) Foam element
(3) Paper element.

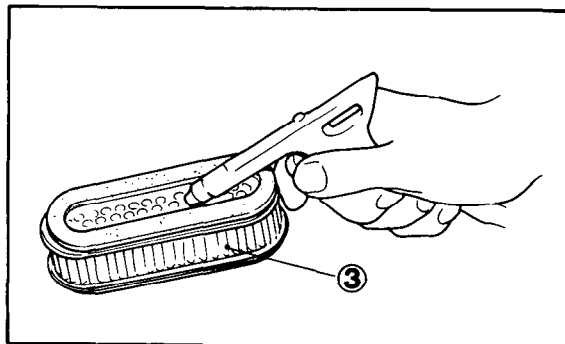

Spark Plug Service

Recommended spark plug: BMR-4A (NGK), W14MR-U (ND) To ensure proper engine operation, the spark plug must be properly gapped and free of deposits.

1. Clean any dirt from around the spark plug base.
2. Remove the plug cap and use the wrench to remove the spark plug.
3. Visually inspect the spark plug. Discard it if the insulator is cracked or chipped.
4. Measure the plug gap with a feeler gauge. The gap should be 0.6–0.7 mm (0.024–0.028 in). Correct as necessary by bending the side electrode.
5. Attach the plug washer. Thread the plug in by hand to prevent cross-threading.
6. Tighten a new spark plug 1/2 turn with the wrench to compress the washer. If you are reusing a plug, it should only take 1/8–1/4 turn after the plug seats.

CAUTION:

- *The spark plug must be securely tightened. An improperly tightened plug can become very hot and possibly damage the tiller.*
- *Never use a spark plug with an improper heat range.*

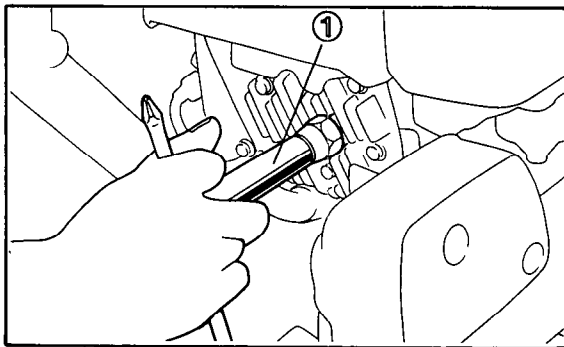

(1) Spark plug wrench

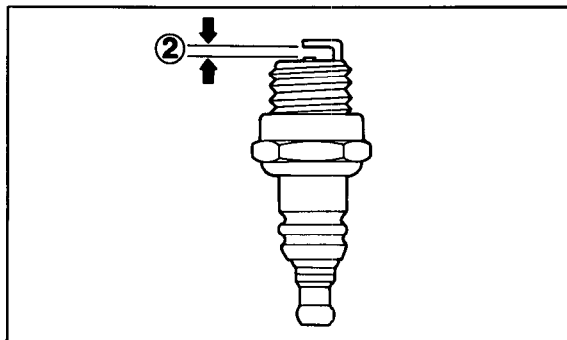

(2) 0.6–0.7 mm (0.024–0.028 in)

Throttle Cable Adjustment

Loosen the lock nut and turn the throttle cable adjusting bolt until free play at the throttle lever is between 5–10 mm (1/4–3/8 in) as shown. Tighten the lock nut securely.

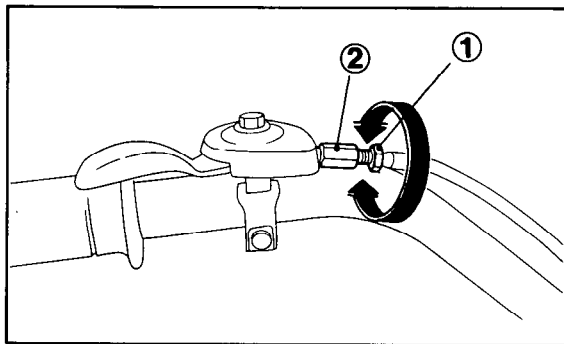

- (1) Lock nut
- (2) Throttle cable adjusting bolt

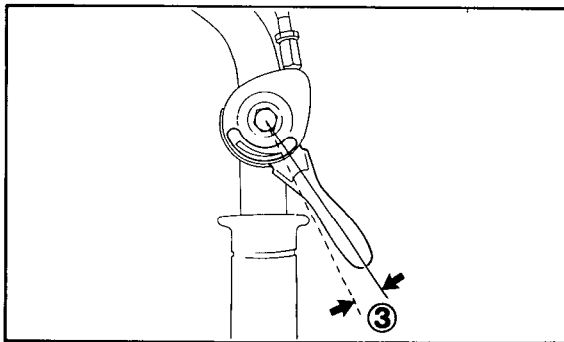

- (3) Free play

Clutch Cable

1. Squeeze the clutch lever lightly until resistance is felt (in this position, the clutch starts to engage), and measure the clearance between the handlebar end and the lever tip as illustrated.
Clutch lever clearance: 45–50 mm (1.77–1.97 in)

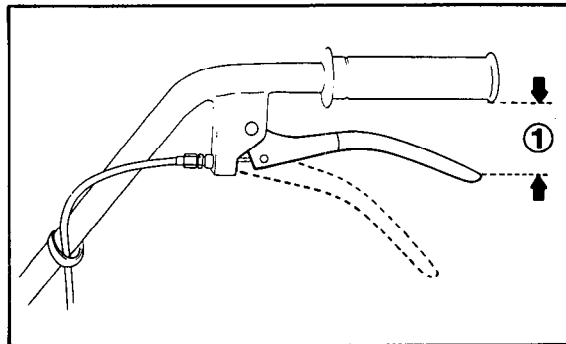

(1) Clearance

2. If the clearance is incorrect, loosen the lock nut and turn the adjusting bolt in or out as required.
3. After adjustment, tighten the lock nut securely. Then start the engine and check for proper clutch lever operation.

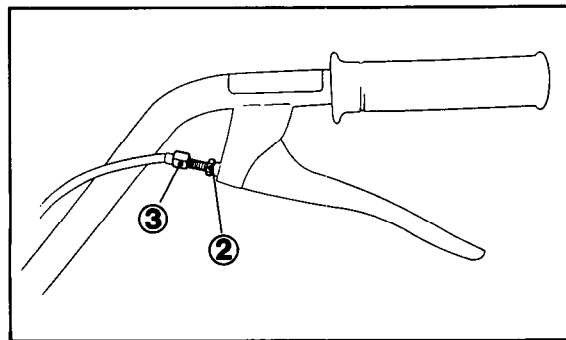

(2) Lock nut (3) Adjusting bolt

Rotor Assembly

Install the tine assemblies and side disks as illustrated below.

NOTE: Side disks can be installed on each side.

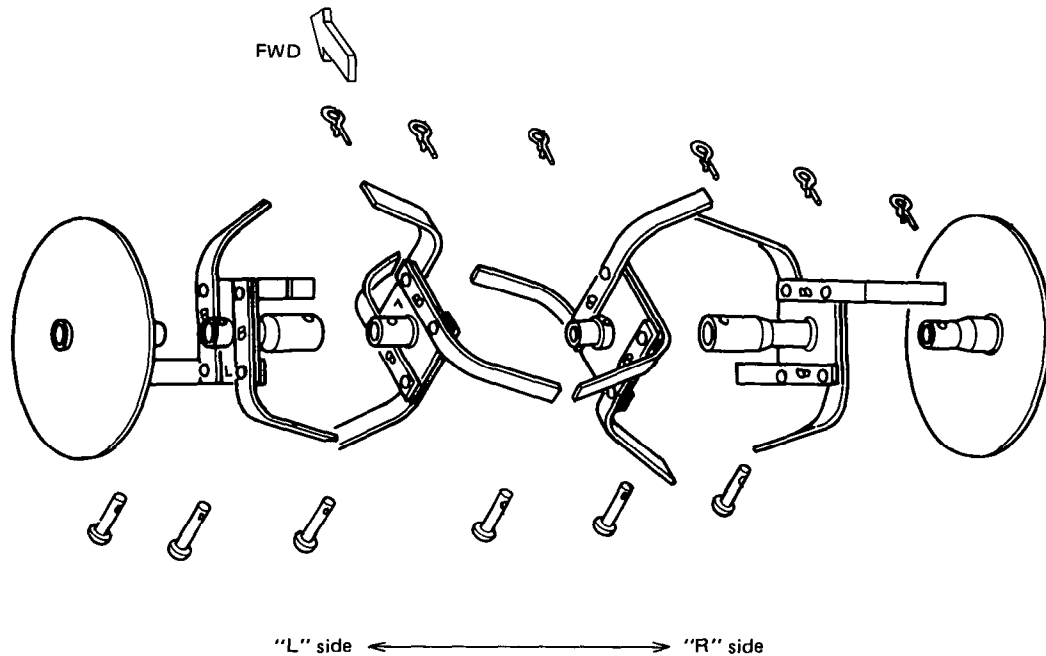

TRANSPORTING/STORAGE

Transporting

Always turn the fuel valve off when transporting the tiller.

Keep it level to avoid fuel and oil leakage, and secure it with a suitable strap or rope.

Preparation For Storage (Over 30 days):

- Close the IN. & EX. valves and the contact breaker points.

Pull the starter handle until it becomes hard to pull (the piston is coming up on the compression stroke).

Both valves and the contact breaker points will be closed. This will protect the valve seats and the points from corrosion.

- Drain the gasoline from the fuel tank and carburetor:

Remove the fuel line from the fuel valve, turn the valve ON and drain all gasoline from the fuel tank into metal container.

Remove the carburetor drain bolt to drain gasoline from carburetor. Reinstall the fuel line and tighten the drain bolt securely. Turn the fuel valve OFF.

⚠ WARNING Gasoline is flammable and explosive under certain conditions. Do not smoke or allow flames or sparks near the equipment while draining fuel.

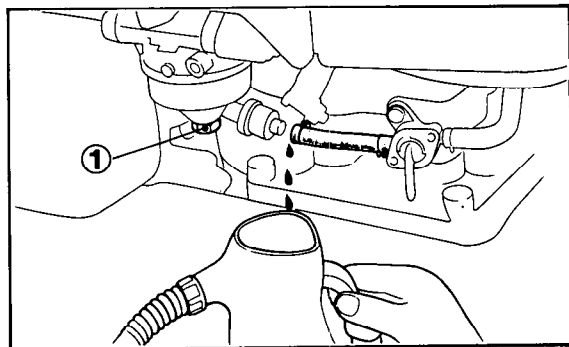

(1) Carburetor drain bolt

- Drain the engine oil and refill the engine with fresh oil.
- Clean the tiller and coat areas of possible rust with a light film of oil.
- Coat the cylinder walls with oil. (If anticipated storage will exceed 1 year.)

Remove the spark plug and pour two or three tablespoonsful of clean oil into the cylinder. Pull the starter handle slowly to distribute the oil over the cylinder walls. Leave the piston on compression to close the valves and points. Reinstall the spark plug.

- Cover the tiller and store on a level surface in a dry, dust-free area.
- Do not place the tiller with the handlebars on the ground. It will cause the oil entering the cylinder or the fuel spillage.

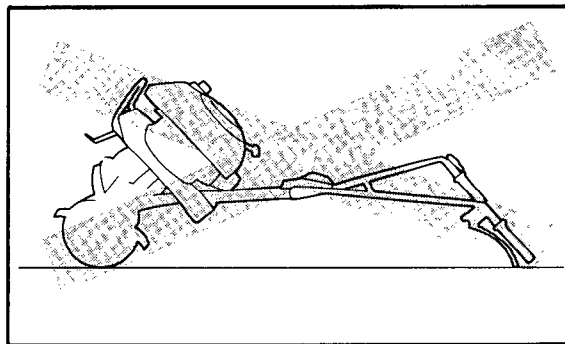

Removal From Storage

- Remove the spark plug and pull the starter handle several times.
- Check that the spark plug is clean and properly gapped, then reinstall and tighten the plug.
- Check engine and transmission oil levels.

NOTE: Oil will deteriorate if left in an engine for a long period of time. Change the engine oil if the tiller has been stored for several times.

- Fill the fuel tank.

 WARNING *Gasoline is flammable and explosive under certain conditions. Do not smoke or allow flames or sparks near the equipment while filling tank. Fill the fuel tank only in a well ventilated area.*

- Check operation and condition of all controls. (If any parts are required, use only genuine Honda parts or their equivalent).
- Turn the fuel valve ON, start the engine and check operation. (Note: If the cylinder was oiled for storage, the engine will smoke for a while after it starts. This will clear up.)

SPECIFICATIONS

Model	F200
Dimensions (L x W x H)1,250 x 585 x 960 mm (49.2 x 23.0 x 37.8 in)
Dry weight27.0 kg (59.5 lb)
Maximum handle height1,045 mm (41.1 in)
Engine	
Model	G100
Type	Single cylinder, 4-stroke, forced air cooled, side valve, gasoline
Displacement/Bore and stroke76 cm ³ (4.6 cu in)/46 x 46 mm (1.81 x 1.81 in)
Ignition timing20° B.T.D.C.
Ignition systemFlywheel magneto
Engine oil capacity0.45 l (0.95 US pt)
Fuel tank capacity0.85 l (1.80 US pt)
Spark plugBMR4A (NGK), W14MR-U (ND)
ClutchInternal expanding shoe
TransmissionPlanetary gear
Oil capacity0.95 l (2.01 US pt)

Warranty Service

Owner Satisfaction

Your satisfaction and goodwill are important to your dealer and to us. Normally, any problems with the product will be handled by your dealer's service department. Sometimes, however, despite the best intentions of all concerned, misunderstandings can occur. If your problem has not been handled to your satisfaction, we suggest you take the following action:

- Discuss your problem with a member of dealership management. Often complaints can be quickly resolved at that level. If the problem has already been reviewed with the Service Manager, contact the owner of the dealership or the General Manager.
- If your problem still has not been resolved to your satisfaction, contact the Customer Relations Department at the regional office of American Honda Motor Co., Inc. in your area. Regional office locations are shown on the following page. We will need the following information in order to assist you.
 - Your name, address, and telephone number
 - Product model and serial number
 - Date of purchase
 - Dealer name and address
 - Nature of the problem

After reviewing all the facts involved, you will be advised of what action can be taken. Please bear in mind that your problem will likely be resolved at the dealership, using the dealer's facilities, equipment, and personnel, so it is very important that your initial contact be with the dealer.

Your purchase of a Honda product is greatly appreciated by both the dealer and American Honda Motor Co., Inc. We want to assist you in every way possible to assure your complete satisfaction with your purchase.



HONDA

HONDA MOTOR CO., LTD. TOKYO, JAPAN

3172900
00X31-729-0002

(AH) (SM) 8507
PRINTED IN JAPAN