

# *Grizzly* *Industrial, Inc.*®

MODEL H6331

## HVHP 2-PC SPRAY GUN SET INSTRUCTION MANUAL



COPYRIGHT © MAY, 2009 BY GRIZZLY INDUSTRIAL, INC.  
WARNING: NO PORTION OF THIS MANUAL MAY BE REPRODUCED IN ANY SHAPE  
OR FORM WITHOUT THE WRITTEN APPROVAL OF GRIZZLY INDUSTRIAL, INC.  
#CR11784 PRINTED IN CHINA.



# **WARNING!**

**Some dust created by power sanding, sawing, grinding, drilling, and other construction activities contains chemicals known to the State of California to cause cancer, birth defects or other reproductive harm. Some examples of these chemical are:**

- **Lead from lead-based paints.**
- **Crystalline silica from bricks, cement and other masonry products.**
- **Arsenic and chromium from chemically-treated lumber.**

**Your risk from these exposures varies, depending on how often you do this type of work. To reduce your exposure to these chemicals: Work in a well ventilated area, and work with approved safety equipment, such as those dust masks that are specially designed to filter out microscopic particles.**

# Table of Contents

<b>SECTION 1: SAFETY</b> .....	<b>4</b>
Safety Instructions for Pneumatic Tools .....	5
Additional Safety Instructions for HVHP Spray Guns .....	6
<b>SECTION 2: INTRODUCTION</b> .....	<b>7</b>
<b>SECTION 3: SET UP</b> .....	<b>8</b>
Inventory .....	8
Assembly .....	8
Controls .....	9
<b>SECTION 4: OPERATIONS</b> .....	<b>10</b>
Spraying .....	10
Atomizing Cap and Fan Adjustments .....	12
<b>SECTION 5: ACCESSORIES</b> .....	<b>13</b>
<b>SECTION 6: MAINTENANCE</b> .....	<b>14</b>
Cleaning .....	14
Lubrication .....	15
Troubleshooting .....	16
Parts Breakdown H6331 .....	18
Large Gun Parts List H6331 .....	18
Large Gun .....	18
Small Gun Parts List H6331 .....	19
Small Gun .....	19
<b>WARRANTY AND RETURNS</b> .....	<b>20</b>

# SECTION 1: SAFETY

## **WARNING**

### **For Your Own Safety Read Instruction Manual Before Operating This Equipment**

The purpose of safety symbols is to attract your attention to possible hazardous conditions. This manual uses a series of symbols and signal words which are intended to convey the level of importance of the safety messages. The progression of symbols is described below. Remember that safety messages by themselves do not eliminate danger and are not a substitute for proper accident prevention measures.



Indicates an imminently hazardous situation which, if not avoided, WILL result in death or serious injury.



Indicates a potentially hazardous situation which, if not avoided, COULD result in death or serious injury.



Indicates a potentially hazardous situation which, if not avoided, MAY result in minor or moderate injury. It may also be used to alert against unsafe practices.

**NOTICE**

This symbol is used to alert the user to useful information about proper operation of the equipment.

## **WARNING**

### **Safety Instructions for Pneumatic Tools**

- KEEP ALL SAFETY DEVICES IN PLACE** and in working order.
- REMOVE ADJUSTING KEYS AND WRENCHES.** Form habit of checking to see that keys and adjusting wrenches are removed from tool before operation.
- KEEP WORK AREA CLEAN.** Cluttered areas and benches invite accidents.
- DO NOT USE IN DANGEROUS ENVIRONMENT.** Do not use pneumatic tools in damp or wet locations, or where any flammable or noxious fumes may exist. Keep work area well lighted.
- KEEP CHILDREN AND VISITORS AWAY.** All children and visitors should be kept at a safe distance from work area.
- MAKE WORKSHOP CHILD PROOF** by locking your shop and shutting off air valves.
- DO NOT FORCE TOOL.** It will do the job better and safer at the rate for which it was designed.
- USE THE RIGHT TOOL.** Do not force tool or attachment to do a job for which it was not designed.
- DO NOT USE UNDER THE INFLUENCE OF DRUGS OR ALCOHOL.**

# **WARNING**

## **Safety Instructions for Pneumatic Tools**

10. **USE PROPER AIR HOSE** for the tool. Make sure your air hose is in good condition and is long enough to reach your work without stretching.
11. **WEAR PROPER APPAREL.** Do not wear loose clothing, gloves, neckties, rings, bracelets, or other jewelry which may get caught in moving parts. Non-slip footwear is recommended. Wear a protective hair covering to contain long hair.
12. **ALWAYS USE SAFETY GLASSES.** Also use a face or dust mask if cutting operation is dusty. Everyday eyeglasses only have impact resistant lenses, they are NOT safety glasses.
13. **WEAR APPROVED HEARING PROTECTION.** Air escaping from pneumatic tools can exceed safe exposure limits and may cause hearing damage with prolonged exposure.
14. **SECURE WORK.** Use clamps or a vise to hold work when practical. It is safer than using your hand and frees both hands to operate tool.
15. **MAINTAIN TOOLS WITH CARE.** Keep tools lubricated and clean for best and safest performance. Follow instructions for lubricating and changing accessories.
16. **REDUCE THE RISK OF UNINTENTIONAL STARTING.** Do not carry tool with hand on trigger and always disconnect from air when not in use.
17. **DISCONNECT TOOLS** before servicing and changing accessories.
18. **DO NOT OVERREACH.** Keep proper footing/balance at all times.
19. **USE THE RECOMMENDED ACCESSORIES.** Consult owner's manual for recommended accessories. The use of improper accessories may cause risk of injury.
20. **CHECK FOR DAMAGED PARTS BEFORE USING.** Check for binding and alignment of parts, broken parts, part mounting, loose bolts, and any other conditions that may affect machine operation. Repair or replace damaged parts.
21. **NEVER LEAVE UNATTENDED TOOL CONNECTED TO AIR.** Disconnect the air hose and do not leave tool until it is relieved of any built up pressure.
22. **NEVER ALLOW UNTRAINED USERS TO USE THIS TOOL WHILE UNSUPERVISED.**
23. **IF YOU ARE UNSURE OF THE INTENDED OPERATION, STOP USING TOOL.** Seek formal training or research books or magazines that specialize in pneumatic tools.
24. **BE AWARE OF HOSE LOCATION WHEN USING PNEUMATIC TOOLS.** Hoses can easily become a tripping hazard when laid across the floor or spread out in a disorganized fashion.

# WARNING

## Additional Safety Instructions for HVHP Spray Guns

1. **READ THIS MANUAL.** This manual contains proper operating instructions for this spray gun.
2. **READ MATERIAL LABELS AND MATERIAL SAFETY DATA SHEETS (MSDS).** Read all the instructions on the packaging label and the MSDS before opening any paint or solvent. This information could save your life.
3. **RESPIRATORY PROTECTION.** Always wear a NIOSH approved respirator when spraying or working around finishing materials.
4. **FIRE EXTINGUISHERS.** Always have a fully charged multi class or class B fire extinguisher in the immediate area.
5. **FLAMMABLE MATERIAL.** NEVER spray near open flame or where any spark could occur.
6. **FRESH AIR.** Always provide adequate exhaust to keep area free of built up vapors. NEVER spray in an enclosed space, or poisoning may occur.
7. **AIR PRESSURE INJURY PROTECTION.** Always disconnect the spray gun from compressed air before cleaning, changing attachments or when performing maintenance of any kind on this tool.
8. **PROTECTIVE CLOTHING.** Protect exposed skin from overspray by wearing a protective suit or other approved garment.
9. **INAPPROPRIATE USE.** DO NOT point or shoot spray gun directly at yourself or another person or animals. Do not attempt to use the spray gun for any other use than it was intended.
10. **STORAGE.** Thoroughly clean and dry spray gun before storage. Store in an approved cabinet. Leaving spray gun reservoir partially full with solvent is a fire hazard.
11. **EYE PROTECTION.** Wear eye protection whenever spraying or cleaning. Solvents and chemicals can cause serious eye injury, which could lead to blindness.
12. **OPERATING PRESSURE.** DO NOT exceed the recommended inlet air pressure. Excessive pressure could cause the spray gun to burst or cause other internal equipment damage.
13. **LOCAL LAWS.** Consult local authorities regarding exhaust and waste disposal requirements.

# SECTION 2: INTRODUCTION

## Foreword

We are proud to offer the Grizzly Model Model H6331 HVHP 2-Pc Spray Gun Set. This model is part of a growing Grizzly family of fine power tools. When used according to the guidelines set forth in this manual, you can expect years of trouble-free, enjoyable operation and proof of Grizzly's commitment to customer satisfaction.

It is our pleasure to provide this manual with the Model H6331. It was written to encourage safety considerations and guide you through general operating procedures and maintenance.

The specifications, details, and photographs in this manual represent the Model H6331 as supplied when the manual was prepared. However, owing to Grizzly's policy of continuous improvement, changes may be made at any time with no obligation on the part of Grizzly.

## Machine Data

### Large HVHP Spray Gun

Type..... HP Siphon Feed  
Fluid Tip..... 1.8 mm  
Air Consumption..... 6.0–8.8 CFM  
Inlet Air Pressure..... 3–4 Bar/43–58 PSI  
Material Capacity..... 1L / 33.8 fl oz  
Maximum Pattern Width..... 180–230 mm

### Small HVHP Spray Gun

Type..... HP Siphon Feed  
Fluid Tip..... 1.4 mm  
Air Consumption..... 4.2–6.5 CFM  
Inlet Air Pressure..... 3–4 Bar/43–58 PSI  
Material Capacity..... 200ml / 6.8 fl oz  
Pattern Width..... 130–180mm

Model H6331 HVHP Spray Gun Set

## Contact Info

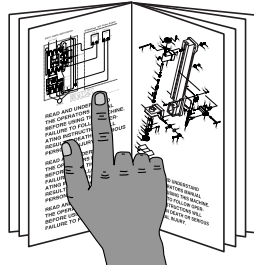
If you have any comments regarding this manual, please contact us:

Grizzly Industrial, Inc.  
C/O Technical Documentation Manager  
P.O. Box 2069  
Bellingham, WA 98227-2069  
Email: manuals@grizzly.com

Most importantly, we stand behind our tools. If you have any service questions or parts requests, please call or write us at the location listed below.

Grizzly Industrial, Inc.  
1203 Lycoming Mall Circle  
Muncy, PA 17756  
Phone: (570) 546-9663  
Fax: (800) 438-5901  
E-Mail: techsupport@grizzly.com  
Web Site: <http://www.grizzly.com>

**⚠ WARNING**



**Read the manual before operation. Become familiar with this tool, its safety instructions, and its operation before beginning any work. Serious personal injury may result if safety or operational information is not understood or followed.**

# SECTION 3: SET UP

## Inventory

Your spray gun left our warehouse in a carefully packed box. If you discover the spray gun is damaged after you have signed for delivery, *please immediately call Customer Service at (570) 546-9663 for advice.*

Save the containers and all packing materials for possible inspection by the carrier or its agent. *Otherwise, filing a freight claim can be difficult.*

After you have unpacked the carton you should find the following:

Model H6331 Inventory (Figure 1)	Qty
A. Small Spray Gun .....	1
B. Storage Case.....	1
C. Large Spray Gun .....	1
D. ¼" NPT Quick Disconnect Fittings.....	2
E. ¼" NPT Push-On Hose Fitting.....	1

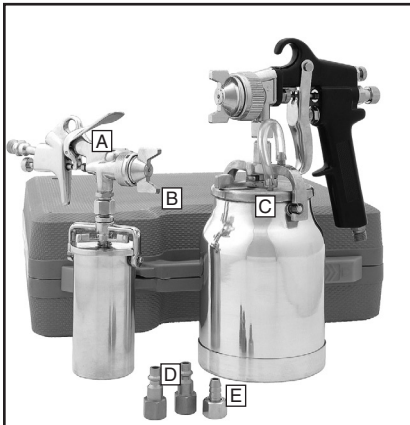


Figure 1. Model H6331 inventory.

## Assembly

1. Attach the air hose to the spray gun with the included male ¼" NPT quick connect fitting.

**Note:** *You have the option of attaching a regulator/gauge directly to the gun for convenient air pressure control at the gun.*

2. Attach the spray gun to an air supply regulated between 43–58 PSI.

**Note:** *For the best results, use a hose that will be dedicated for spray use only. Do not use a hose that has been used with an in-line oiler as the oil can contaminate the paint being sprayed or clog an in-line filter.*



# Controls

- **Fluid Control:** Controls the paint volume that flows out of the atomizing cap.
- **Pattern Control:** Controls the spray pattern from round to a wide fan.
- **Atomizing Cap:** Controls the angle of the spray pattern from vertical to horizontal.
- **Two Stage Trigger:** Stage one releases compressed air for blowing off the workpiece. Stage two sprays material.
- **Reservoir:** Holds thinned and non-thinned paints in an easy-to-clean spun aluminum canister.
- **Reservoir Quick Release Lock:** Allows quick removal of reservoir.

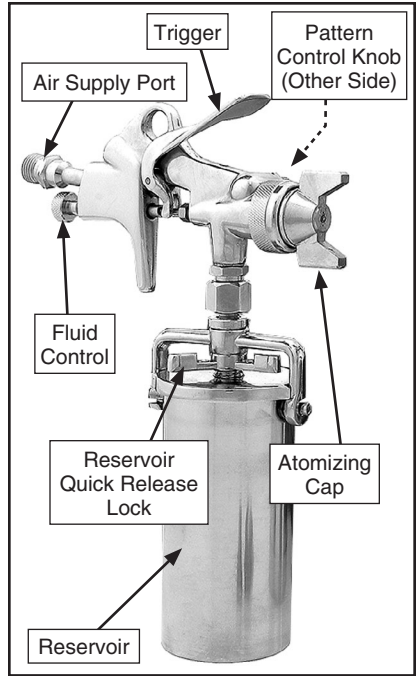


Figure 3. Controls.

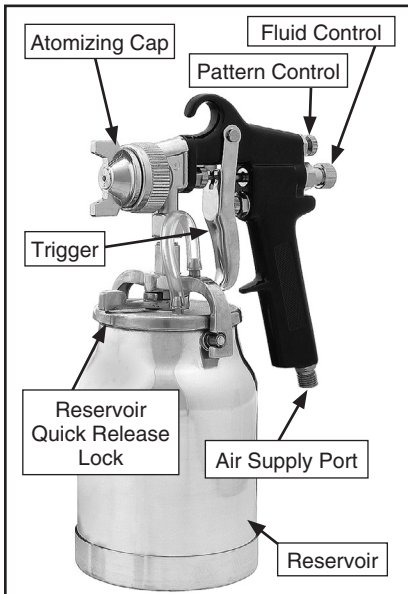


Figure 2. Controls.

# SECTION 4: OPERATIONS

**⚠ DANGER**



**EXPLOSION HAZARD! DO NOT smoke or have any source of flame or spark near spraying. Vapors will explode if ignited.**

**⚠ WARNING**



**RESPIRATORY HAZARD! Always use a NIOSH approved respirator when using spray equipment. Failure to protect your lungs can lead to respiratory illness and nervous system damage.**

**⚠ WARNING**



**TOXIC FUMES! Always use an approved spray booth or well ventilated area when spraying. NEVER spray in an confined space where toxic fumes and flammable vapors can accumulate to deadly levels.**

## Spraying

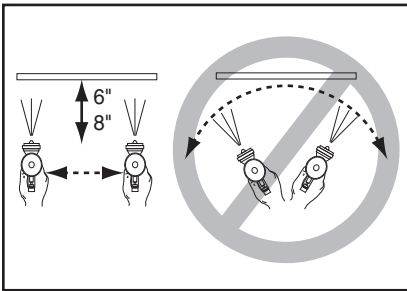
The Model H6331 spray gun set is designed to spray low to medium viscosity liquids, like lacquers, stains, primers, multi-component paints, acrylics, epoxies, etc. It is ideal for auto body touch-ups, woodworking projects, or projects with hard to reach areas.

### To use your spray gun:

1. Read and follow the material manufacturer's instructions for spraying, mixing, safety, disposal, and any other instruction on the label or Material Safety Data Sheet (MSDS).
2. Ensure the reservoir is securely tightened and all other fittings are secure to avoid air leaks or material spills.
3. Set the inlet air pressure (the air coming to the spray gun) to the lowest pressure recommended in **Machine Data** on **Page 7** or to the material manufacturer's recommendations, then adjust higher as necessary.
4. Adjust the atomizing cap to vertical or horizontal. Refer to **Atomizing Cap and Fan Adjustments** on **Page 12** for further explanation.
5. Using a paint strainer, fill the reservoir with the liquid to be sprayed.

**Note:** *Trial and error are necessary to achieve the results you want along with a fair amount of practice. Test your material flow and spray pattern on a piece of cardboard or some scrap of material similar to your project.*

6. Adjust the fluid control knob to start with a low volume of material and keep the atomization as low as possible. You will need to use a combination of fluid control, inlet air pressure, air flow control and stroke speed to achieve the results you want. Spray so the material wets out nicely without running or sagging.
7. Use the pattern control knob to adjust the spray fan to your desired pattern.
8. Keep the gun tip perpendicular, equidistant, and 6-8" from the work (as shown in **Figure 4**) when spraying. Do not allow your wrist to bend. This will cause the gun to arc across the surface and distribute the material unevenly, possibly creating sags and dry spots.

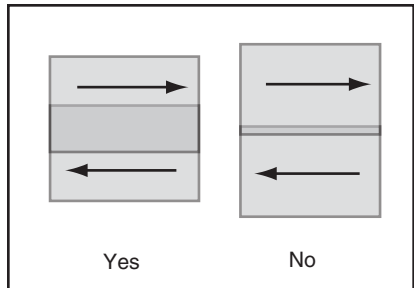


**Figure 4.** Spray technique.

## NOTICE

Tipping spray gun may cause material to spill out of the cup. Always hold the spray gun perpendicular to the ground to avoid potential spills and gravity feed problems.

9. Begin spraying 2-3 inches before the workpiece and continue through the end of the workpiece. Continue the motion for a few inches past the work until you are ready for the return stroke.
10. Maintain an even speed when spraying.
11. Overlap each stroke by 50%. This will ensure even coverage, as shown in **Figure 5**. Overlapping less than 50%, as shown in the figure to the right, may lead to missed spots or streaky results.



**Figure 5.** Overlap technique.

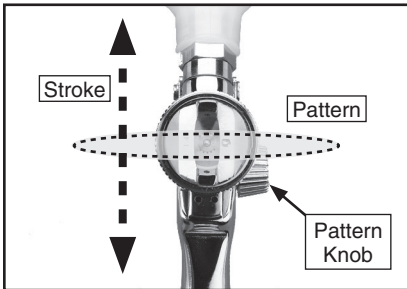
12. The spray stroke should have even consistency and parallel edges. If it doesn't please refer to **Troubleshooting** on **Page 16**.

## CAUTION

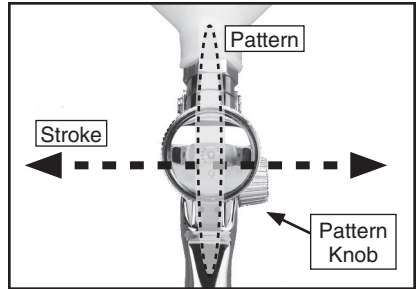
CONTAMINATION HAZARD! Dispose of paint waste in a responsible manner! Follow manufacturer's recommendations and local laws regarding disposal.

# Atomizing Cap & Fan Adjustments

The atomizing cap can be adjusted for horizontal or vertical spraying patterns. Spraying in the wrong direction may lead to material build up on the atomizing cap horn. Many performance problems are caused by clogged atomizing holes on the atomizing cap horns (refer to **Cleaning** on Page 14).

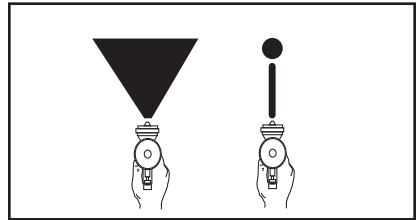


**Figure 6.** Typical set up for vertical stroke direction with horizontal fan pattern.



**Figure 7.** Typical set up for horizontal spray stroke with vertical fan pattern.

Rotating the pattern adjustment knob (see **Figure 7**) changes the shape of the spray pattern from a wide spray to a narrow spray, as shown in **Figure 8**.



**Figure 8.** Fan adjustment.

# SECTION 5: ACCESSORIES

## G6261—Campbell Hausfeld™ Water Filter

Remove damaging water vapor before it reaches your pneumatic tools. This highly effective, five micron filter features a see-through bowl and easy in-line connections. 150 PSI maximum air pressure. ¼" NPT.



**Figure 9.** G6261 Campbell Hausfeld™ water filter.

## G8114—¾" x 25 Ft. Air Hose

## G8115—¾" x 50 Ft. Air Hose

## G8116—¾" x 100 Ft. Air Hose

Multi-purpose red rubber air hose is flexible and abrasion resistant. Rated for 200 PSI, this air hose has a bursting strength of 800 PSI and ¼" NPT ends.



**Figure 10.** Red rubber air hose.

## H7274—Campbell Hausfeld™ Pressure Regulator

This mini Series Regulator provides regulated output pressure of 0 to 125 PSI for proper tool operation. Locking pressure knob prevents accidental adjustments. 15 SCFM flow capacity @ 90 PSI. ¼" NPT.



**Figure 11.** H7274 Campbell Hausfeld™ pressure regulator.

## H3174—Air Blow Gun with 2 Tips

This air blow gun includes a safety tip and rubber tip for all normal air cleaning jobs. ¼" NPT .



**Figure 12.** H3174 Air Blow Gun with 2 Tips.

**Call 1-800-523-4777 To Order**

# SECTION 6: MAINTENANCE

## Cleaning

### **! WARNING**

**EXPLOSION HAZARD!** Chlorinated Solvents like Trichloroethane and Methylene Chloride (methyl chloride) can chemically react with aluminum and may explode. Many parts in spray guns are made of aluminum. Read solvent label carefully before using solvent.

### **NOTICE**

**DO NOT** soak the spray gun body in solvent. Prolonged exposure to solvent will rapidly deteriorate the spray gun washers and seals. Ignoring this notice will void your warranty.

Proper cleaning is the best way to ensure trouble free performance from your spray gun. If your gun is not thoroughly cleaned, damage and poor spraying will result. Problems caused by improper cleaning will not be covered by the warranty. Clean the spray gun immediately after each use.

#### To clean your spray gun:

1. Spray a small amount of solvent through the spray gun.

**Note:** Check with local laws regarding this practice. Spraying solvents into the air may be illegal in your area. A cabinet style spray gun cleaner may be required.

2. Disconnect the gun from the compressed air!

3. Remove the reservoir and lid.
4. Disassemble the gun by unscrewing the fluid control knob, then remove the spring and needle (Figures 13 and 14).

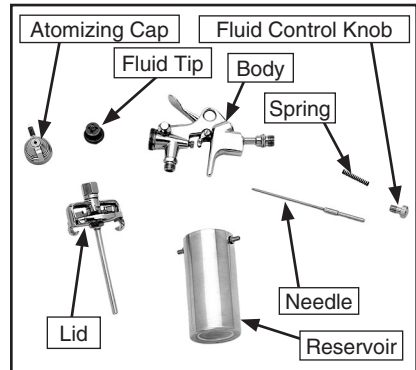


Figure 13. Small gun disassembled.

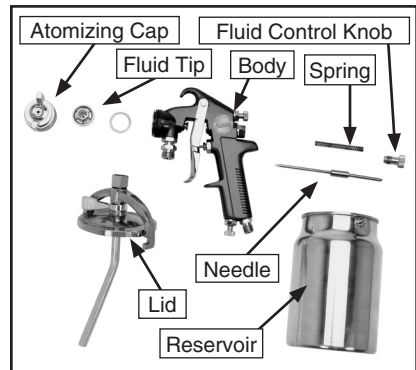


Figure 14. Large gun disassembled.

5. Unscrew the atomizing cap with your fingers and the fluid tip with a wrench. The fully disassembled gun should look like Figure 13 and 14.

- Put on safety goggles, rubber gloves, and rinse these parts thoroughly in solvent, then dry with compressed air or let air dry.

**Note:** *If the small holes in the atomizing cap become blocked, soak in clean solvent. If the blockage still exists, clear the blockage with a small needle, taking great care to not enlarge or damage the hole. Damage to the hole will create a disrupted spray pattern.*

- Use an old tooth brush with solvent to clean the inner orifice and other hard to reach areas on the outside of the spray gun body.
- Wipe the gun body with a lint free shop towel to dry.

## Lubrication

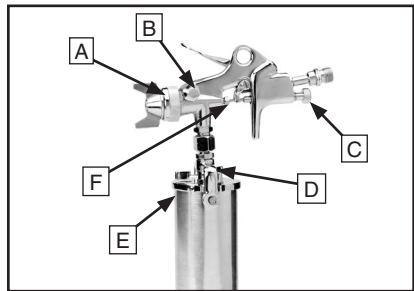
---

---

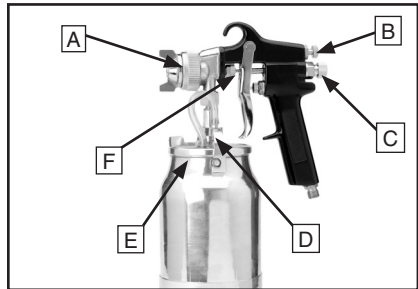
**Lubricate the following areas with spray gun lube after cleaning:**

- Atomizing Cap Threads and Gasket
- Pattern Control Knob
- Fluid Control Knob
- Reservoir Quick Release Lever
- Reservoir Gasket
- Trigger Pin

After each cleaning, apply a thin film of petroleum jelly to the needle spring before reassembling.








**Figure 15.** Lubrication points.



**Figure 16.** Lubrication points.

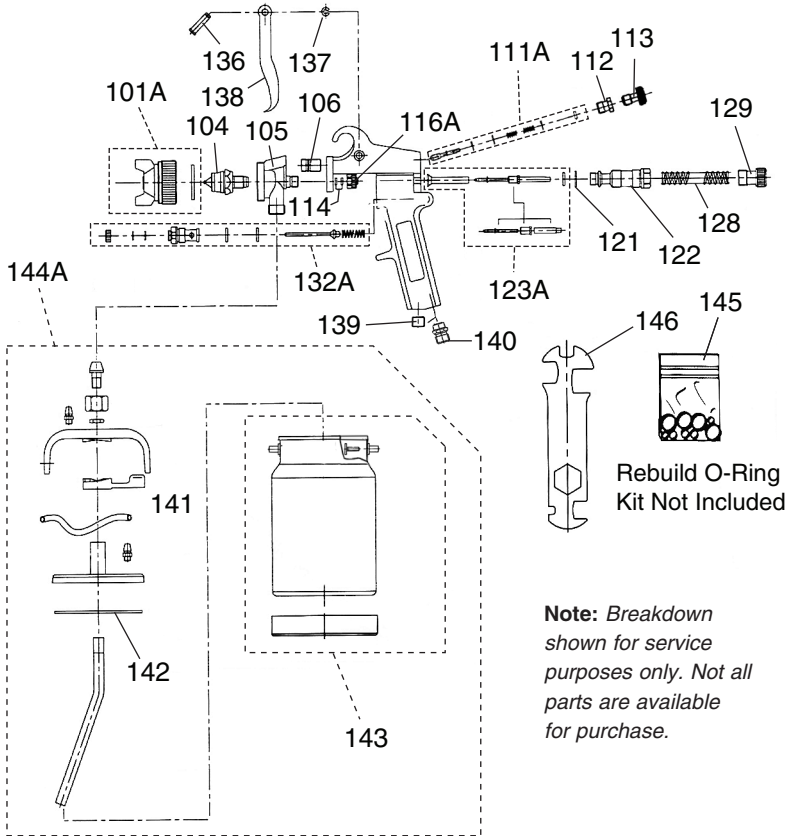
# Troubleshooting

Symptom	Possible Cause	Solution
Fluttering or spitting spray. 	<ol style="list-style-type: none"> <li>1. Dry or worn fluid tip seat permits air to seep into fluid passage.</li> <li>2. Material level too low.</li> <li>3. Fluid tip or filter obstructed.</li> <li>4. Dry needle packing.</li> </ol>	<ol style="list-style-type: none"> <li>1. Tighten fluid tip or replace seat with new one.</li> <li>2. Add material.</li> <li>3. Clean</li> <li>4. Lubricate needle.</li> </ol>
Uneven top or bottom pattern. 	<ol style="list-style-type: none"> <li>1. Atomizing cap holes are obstructed.</li> <li>2. Build-up material on top or bottom of fluid tip.</li> <li>3. Build-up material on atomizing cap is on needle seat.</li> </ol>	<ol style="list-style-type: none"> <li>1. Clear holes.</li> <li>2. Clean.</li> <li>3. Clean.</li> </ol>
Right or left arc pattern. 	<ol style="list-style-type: none"> <li>1. Left or right side horn holes are plugged.</li> <li>2. Build-up on left or right side of fluid tip.</li> <li>3. Build-up of material inside atomizing cap.</li> </ol>	<ol style="list-style-type: none"> <li>1. Clear holes.</li> <li>2. Clean.</li> <li>3. Clean.</li> </ol>
Heavy deposit of material in center. 	<ol style="list-style-type: none"> <li>1. The material flow exceeds the atomizing cap capacity.</li> <li>2. Inlet air pressure is too low.</li> <li>3. Material is too thick.</li> </ol>	<ol style="list-style-type: none"> <li>1. Reduce fluid flow.</li> <li>2. Increase inlet air pressure.</li> <li>3. Thin material.</li> </ol>
Narrow center pattern. 	<ol style="list-style-type: none"> <li>1. Volume control turned in too far.</li> <li>2. Inlet air pressure too high.</li> <li>3. Fluid pressure is too low.</li> <li>4. Material is too thin.</li> </ol>	<ol style="list-style-type: none"> <li>1. Increase volume.</li> <li>2. Reduce inlet air pressure.</li> <li>3. Increase fluid pressure.</li> <li>4. Adjust material.</li> </ol>
No spray output.	<ol style="list-style-type: none"> <li>1. No pressure at gun.</li> <li>2. Fluid passages dirty.</li> <li>3. Fluid control closed.</li> <li>4. Out of paint.</li> <li>5. Material too thick.</li> </ol>	<ol style="list-style-type: none"> <li>1. Check air supply.</li> <li>2. Clean gun, remove any obstructions.</li> <li>3. Open.</li> <li>4. Refill.</li> <li>5. Thin to manufacturer's recommendations.</li> </ol>



<b>Symptom</b>	<b>Possible Cause</b>	<b>Solution</b>
Excessive over-spray.	<ol style="list-style-type: none"> <li>1. Fluid pressure too high.</li> <li>2. Gun is too far from surface.</li> <li>3. Spraying too fast.</li> </ol>	<ol style="list-style-type: none"> <li>1. Reduce fluid pressure.</li> <li>2. Keep gun at recommended distance.</li> <li>3. Slow down and maintain consistent, even parallel stroke.</li> </ol>
Unable to control spray fan.	<ol style="list-style-type: none"> <li>1. Pattern adjustment screw is not seating properly.</li> <li>2. Atomizing cap is loose.</li> </ol>	<ol style="list-style-type: none"> <li>1. Clean or replace.</li> <li>2. Tighten atomizing cap.</li> </ol>
Runs and sags.	<ol style="list-style-type: none"> <li>1. Over diluted paint.</li> <li>2. Spray sweep is too slow.</li> <li>3. Tip too close to workpiece.</li> <li>4. Damaged seal.</li> </ol>	<ol style="list-style-type: none"> <li>1. Refer to paint manufacture dilution ratios.</li> <li>2. Speed up spraying sweeps.</li> <li>3. Move tip farther away from workpiece.</li> <li>4. Replace damaged seals.</li> </ol>
Material leaks from cup.	<ol style="list-style-type: none"> <li>1. Cap not secure.</li> <li>2. Cup not tight on gun body.</li> <li>3. Leaking from cap vent hole.</li> </ol>	<ol style="list-style-type: none"> <li>1. Tighten.</li> <li>2. Tighten.</li> <li>3. Hold gun upright; do not tilt.</li> </ol>
Material leaks from gun.	<ol style="list-style-type: none"> <li>1. Fluid tip loose.</li> <li>2. Dry or damaged seals.</li> <li>3. Excessive pressure.</li> </ol>	<ol style="list-style-type: none"> <li>1. Tighten.</li> <li>2. Replace seals.</li> <li>3. Reduce pressure.</li> </ol>
Thick dimpled finish, aka "Orange Peel."	<ol style="list-style-type: none"> <li>1. Holding gun too close to surface.</li> <li>2. Inlet air pressure too low.</li> <li>3. Material not properly mixed.</li> <li>4. Surface is dirty or oily.</li> </ol>	<ol style="list-style-type: none"> <li>1. Spray at recommended distance.</li> <li>2. Check inlet air pressure.</li> <li>3. Follow manufacturer's instructions.</li> <li>4. More surface prep is required.</li> </ol>
Dry Spray.	<ol style="list-style-type: none"> <li>1. Inlet air pressure too high.</li> <li>2. Gun too far from surface.</li> <li>3. Gun stroke too fast.</li> </ol>	<ol style="list-style-type: none"> <li>1. Lower inlet air pressure.</li> <li>2. Keep gun at recommended distance.</li> <li>3. Slow down and maintain consistent even parallel stroke.</li> </ol>
Gun leaks from fluid tip.	<ol style="list-style-type: none"> <li>1. Debris will not let the needle seat with the fluid tip.</li> </ol>	<ol style="list-style-type: none"> <li>1. Clean or replace both.</li> </ol>
Contaminated paint, aka "Fish Eyes."	<ol style="list-style-type: none"> <li>1. Work surface has oil spots, or was improperly cleaned and primed.</li> <li>2. Water or oil in the air line.</li> </ol>	<ol style="list-style-type: none"> <li>1. Wait until finish is dry and cured, re-sand clean and re-prime, and repaint.</li> <li>2. Install an in-line air filter.</li> </ol>

# Parts Breakdown H6331 Large Gun

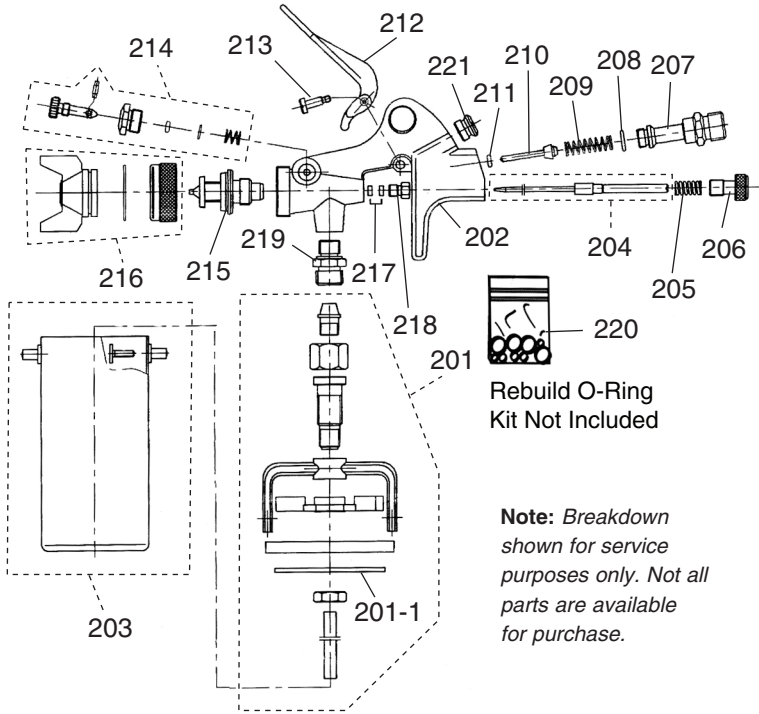


## Large Gun Parts List H6331

REF	PART #	DESCRIPTION
101A	PH6331101A	NOZZLE ASSEMBLY
104	PH6331104	FLUID NOZZLE
105	PH6331105	HEAD
106	PH6331106	CONTROL SCREW
107	PH6331107	GUN BODY
111A	PH6331111A	NEEDLE ASSEMBLY
112	PORS005	O-RING 4.5 X 1.5 S5
113	PH6331113	CONTROL SCREW
114	PH6331114	GASKET
116A	PH6331116A	CONTROL ASSEMBLY
121	PH6331121	GASKET
122	PH6331122	HOUSING
123A	PH6331123A	LOCKNUT
128	PH6331128	COMPRESSION SPRING

REF	PART #	DESCRIPTION
129	PH6331129	CONTROL SCREW
132A	PH6331132A	NEEDLE ASSEMBLY
136	PH6331136	PIVOT PIN
137	PEC13M	E-CLIP 5MM
138	PH6331138	TRIGGER
139	PH6331139	PLUG
140	PH6331140	SPECIAL CONNECTOR
141	PH6331141	TUBE
142	PH6331142	SEAL
143	PH6331143	CANISTER 1LITER
143A	PH6331143A	CANISTER ASSEMBLY
145	PH6331145	O-RING KIT
146	PH6331146	UNIVERSAL WRENCH

# Small Gun



Rebuild O-Ring  
Kit Not Included

**Note:** Breakdown shown for service purposes only. Not all parts are available for purchase.

## Small Gun Parts List H6331

REF PART #	DESCRIPTION
201	PH6331201 CONTAINER COVER SET
201-1	PH6331201-1 GASKET
202	PH6331202 GUN BODY
203	PH6331203 CANISTER 20ML
204	PH6331204 FLUID NEEDLE SET
205	PH6331205 COMPRESSION SPRING
206	PH6331206 FLUID KNOB
207	PH6331207 AIR INLET PLUG
208	PORP008 O-RING 7.8 X 1.9 P8
209	PH6331209 COMPRESSION SPRING
210	PH6331210 AIR VALVE SEAT

REF PART #	DESCRIPTION
211	PH6331211 SEAT SEAL
212	PH6331212 TRIGGER
213	PH6331213 TRIGGER PIN
214	PH6331214 PATTERN SCREW
215	PH6331215 FLUID NOZZLE
216	PH6331216 AIR CAP SET
217	PH6331217 SEALING RING
218	PH6331218 DIRECTIONAL SCREW
219	PH6331219 PAINT INLET JOINT
220	PH6331220 O-RING KIT
221	PH6331221 SLOTTED PLUG

