

## INSTRUCTIONS FOR USE

1. Lay the pants on the moving portion and allow them to sink to the required height.
2. Half close the panel. Now pull the fabric of the pants tight to avoid false creases.
3. Push the tensloning arm downwards.
4. Insert the electrical plug into the socket. Push in the thermostat knob. The control lamp should now light and the heat-up period will start.

As soon as the press reaches the correct working temperature, the thermostat will automatically act to switch off the heating current. The pressing cycle lasts approximately 30 minutes.

**Important:** Always disconnect the pants press from the electrical outlet when not in use.

## IMPORTANT SAFEGUARDS

When using your Euro-Pro Pants Press basic safety precautions should always be followed, including the following:

1. Read all instructions before using the press.
2. Use the press only for its intended use.
3. To protect against a risk of electric shock, do not immerse the press or any part of the press in water or other liquids.
4. The press should always be turned off before plugging into or unplugging from outlet. Never yank cord to disconnect from outlet; instead, grasp plug and pull to disconnect.
5. Do not allow cord to touch hot surfaces. Wrap cord loosely around the press when storing.
6. Always disconnect the press from electrical outlet when not in use.
7. Do not operate the press with a damaged cord, or plug, or if the press has been dropped or damaged. To avoid the risk of electric shock, do not disassemble or attempt to repair the press. Return the press to the factory (see warranty) for examination and repair. Incorrect repair can cause a risk of electrical shock or injury to persons when the press is used.
8. Close supervision is necessary for any appliance being used by or near children.
9. Do not operate in the presence of explosive and/or flammable fumes.
10. This appliance is intended for household use ONLY and not for commercial or industrial use.

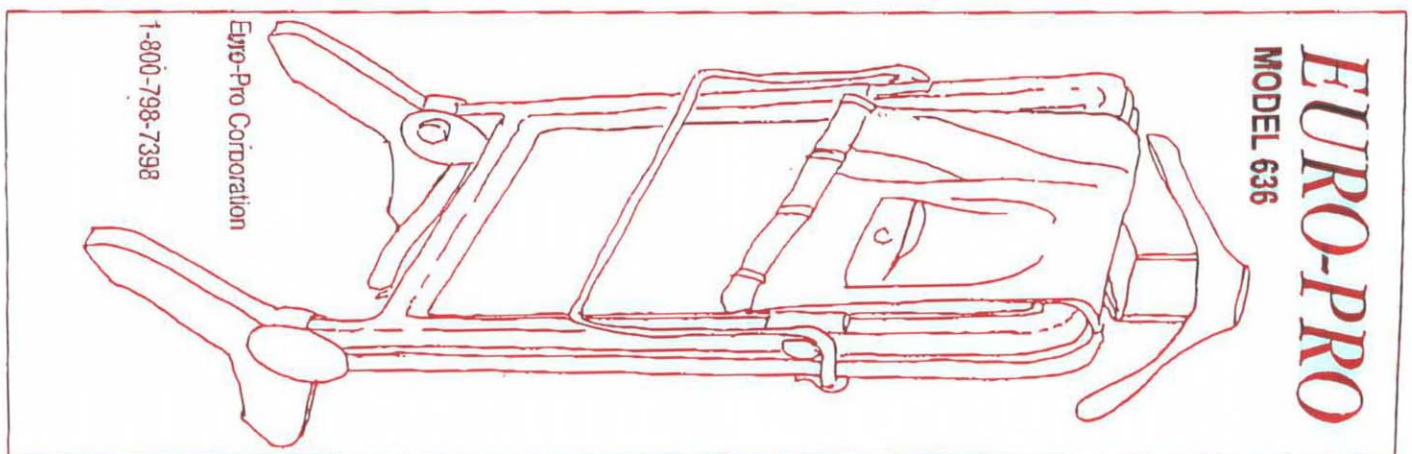

**EURO-PRO**  
MODEL 636

Euro-Pro Corporation

1-800-798-7398

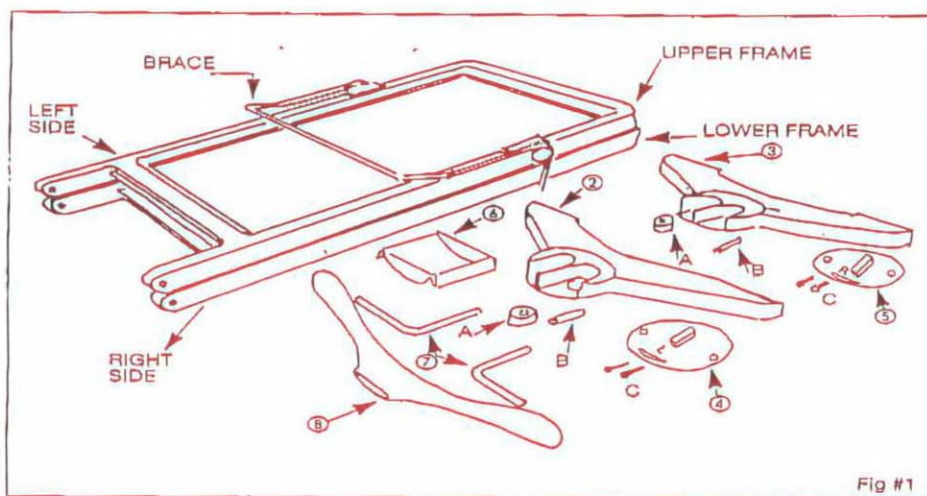

Fig #1

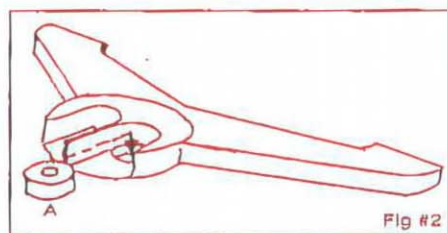

Fig #2

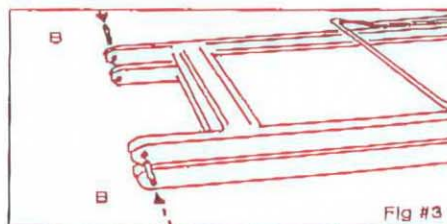

Fig #3

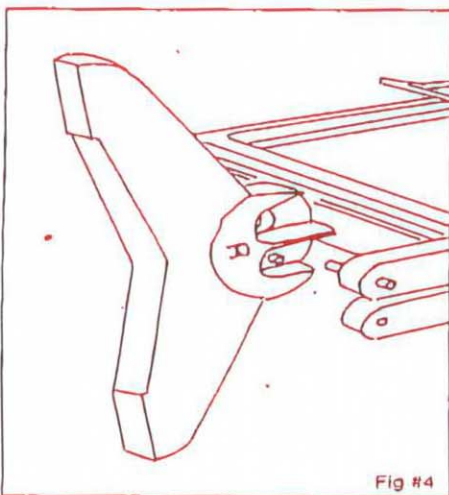

Fig #4

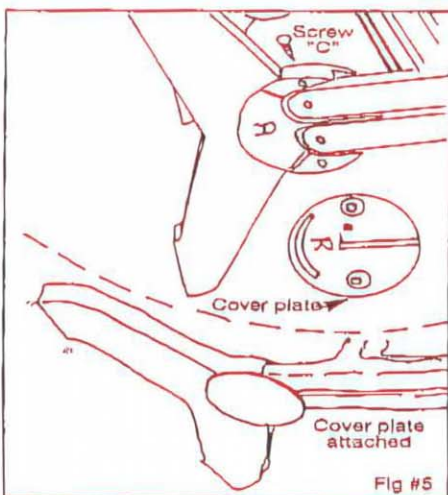

Fig #5

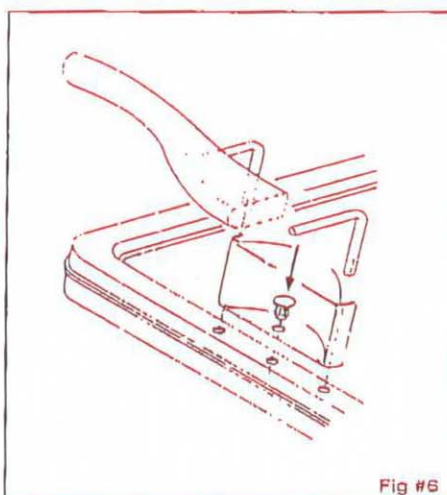

Fig #6

## CONTENTS

(See Figure 1)

- |                                    |                             |
|------------------------------------|-----------------------------|
| 1. Pants Press.                    | 6. Accessory Tray.          |
| 2. Left Leg (Marked "L").          | 7. Two Coat Stand Supports. |
| 3. Right Leg (Marked "R").         | 8. Coat Stand.              |
| 4. Left Cover Plate (Marked "L").  | A. Two Rubber Pads.         |
| 5. Right Cover Plate (Marked "R"). | B. Two Plastic Pins.        |
|                                    | C. Four Screws.             |

## INSTRUCTIONS FOR ASSEMBLY

Congratulations! You are the owner of the EURO-PRO European pants press. Only a few simple steps are required to assemble your pants press. Please note that the parts are designed to fit very tightly in order to insure that the pants are held taught for proper pressing.

- Place the pants press, with the brace facing up, on a table as show in Figure 1.
- Lay out the parts for easy identification as shown in Figure 1. The parts are identified with numbers or letters.
- Place the rubber pad "A" in the round depression inside the right leg #3. (See Figure 2).
- Insert pin "B" into the hole in the upper frame. (See Figure 3).
- Please note:**  
To attach the right leg to the bottom of the upper frame some manipulating is necessary because of the tight fit required for perfect pressing. First, manipulate pin "B" into the hole of the rubber pad "A". (See Figure 4). Then squeeze the bottom of the lower frame into the leg until it fits in completely. (See Figure 5).
- Attach the cover plate #4 (marker "R") to the leg, as shown in Figure 5. Using a screw driver, install the two screws "C".
- Repeat steps 2, 3, 4, and 5 for the left leg.
- Place the pants press on the floor.
- Insert the two coat stand supports in the holes in the coat stand. Install the coat stand and the accessory tray on the pants press as shown in Figure 6.

Euro-Pro Consumer Help-Line 1-800-798-7398

Our operators will be pleased to assist you Monday to Friday, 9 - 5 Eastern Standard Time.