

**DuraWatt DSATX**  
**220-Watt DC-DC ATX Power Supply**  
**User Manual**  
Version 1.0

**Table of Contents**

<b>1. Getting Started .....</b>	<b>1</b>
<b>1.1. Introduction .....</b>	<b>1</b>
1.2. Product Photo .....	2
1.3. Block Diagram.....	2
1.4. Included Contents and Optional Accessories.....	2
2.1. Recommended Additional Supplies.....	3
2.2. Recommended Tools.....	3
2.3. Connection Overview Diagram.....	3
2.4. Precautions and Warnings.....	3
2.5. Detailed Connection Diagram .....	4
2.6. Bench Testing .....	4
2.7. Quick Installation Steps .....	5
<b>3. User Guide.....</b>	<b>5</b>
3.1. Theory of Operation.....	5
3.2. Modes of Operation .....	5
3.3. LED Codes .....	6
3.4. Basic Mode Timing Diagram .....	6
3.5. Features Explained.....	6
<b>4. Serial Port Connectivity.....</b>	<b>8</b>
4.1. Serial Port Adapters .....	8
4.2. Serial Port Overview .....	8
4.3. Basic Programming Control .....	8
4.4. Diagnostic Feed .....	8
4.5. Extended Basic Programming Examples .....	9
4.6. Advanced Features .....	10
4.7. Advanced Feature Tables .....	10
<b>5. Specifications.....</b>	<b>11</b>
5.1. Electrical .....	11
5.2. Mechanical.....	11
5.3. Connector Pin Locations.....	12
<b>7. Mpegbox.com Limited Warranty .....</b>	<b>13</b>

## **1. Getting Started**

### **1.1. Introduction**

Thank you for purchasing a DSATX 220 Watt Automotive Power Supply. Please take some time to read through this manual before attempting to use this product.

The DSATX is the most advanced DC-DC Automotive Computer Power Supply available. It is capable of properly powering most Pentium 4 and AMD based computers in a motor vehicle as well as their accessories. Its advanced microprocessor control enables features such as Startup/Shutdown Sequencing, Low Voltage

Battery Protection, and Temperature Protection. Features also include Serial Port Control, Diagnostics, and Upgradeability. Desktop computer motherboards are typically not designed to work in automotive environments, the design and engineering that went into the DSATX makes every attempt to compensate for this. Having purchased a DSATX, you will rest assured that you've invested in a flexible product that can grow and expand with your automotive computing system.

## 1.2. Product Photo



**DSATX**

## 1.3. Block Diagram

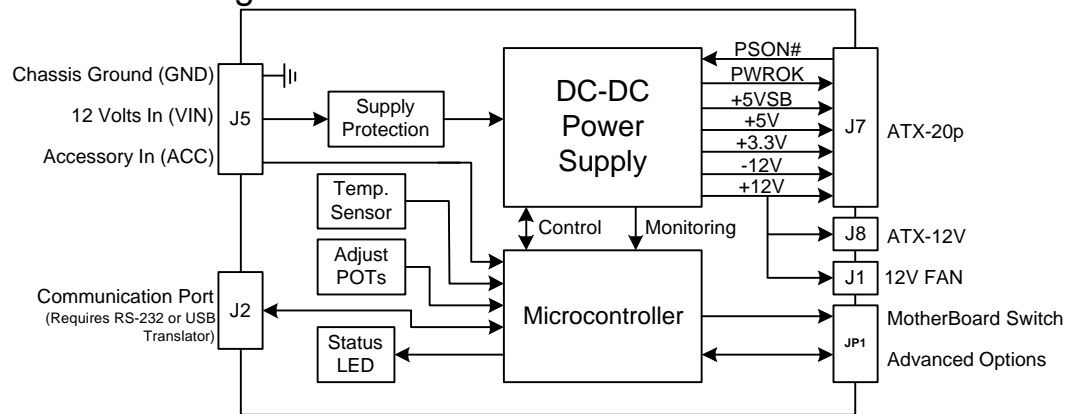

## 1.4. Included Contents and Optional Accessories

### Included:

- 1 : DSATX 220 Watt Power Supply
- 1 : 9" 20-pin ATX Power Cable with 2 HDD Power Connectors and 1 Floppy Connector
- 1 : 12" 4-pin ATX 12V Power Cable (CPU Power Cable)
- 2 : 0.1" Shunt Jumpers
- 1 : 24" 2-pin to 2-pin Mother Board Power Switch Cable
- 3 : Insolated Terminal Ring Crimp/Solder Connectors 12-10AWG

### Optional:

- Acroname Serial Port Adapter *PN:S13-SERIAL-INT-CONN*
- Acroname USB Serial Adapter *PN:S19-USB-SERIAL-INT-CONN*
- 12" 20-pin ATX Power Cable with 2 HDD Power Connectors and 3 Floppy Connectors

## 2. Installation Guide

### 2.1. Recommended Additional Supplies

- 12 AWG Hookup Wire for Vin and Gnd Inputs (Minimum Recommended Gauge)
- 12-24 AWG Hookup Wire for Acc Input (Very little current flows through this wire)
- Mounting Screws (4-40 or 6-32)
- Mounting Standoffs (Optional)
- Power Supply Cooling Fan (or assure adequate airflow over the DSATX)
- Custom Enclosure

### 2.2. Recommended Tools

- Soldering Iron and or Crimp Tool (Secure Input Power Connections)
- Philips Jewelers Screwdrivers (for P1 P2 Adjustment Pots)
- Philips Head Screwdriver (for Mounting Screws and J5 Terminal Screws)

### 2.3. Connection Overview Diagram

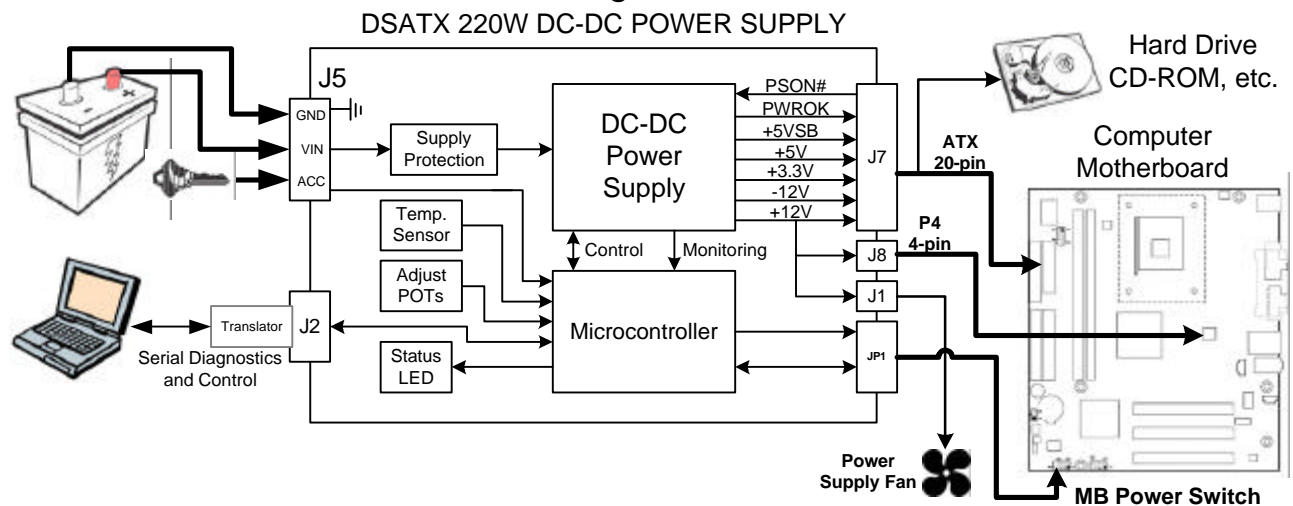

### 2.4. Precautions and Warnings

Operating a personal computer in a motor vehicle can be dangerous. Improper use or negligence can result in damage and or loss of life to self and others. Safety precautions must be considered when operating a personal computer in a motor vehicle. Displays must not be distracting to the driver and should not display motion video or otherwise distracting content. Check with the local government in your area for laws and guidelines regarding the use of potentially distracting electronic devices in motor vehicles. Mpegbox.com and the people responsible for its content shall not be held responsible for loss or damage as a result of the content, procedures, or the use of the product/s outlined in this manual. A personal computer used in a motor vehicle should only be operated as a personal computer when then vehicle is not moving. Use this product at your own risk. Various safety features are built into this product and any attempt to override them will void any warranties and may cause increased risk of damage to persons or property.

## 2.5. Detailed Connection Diagram

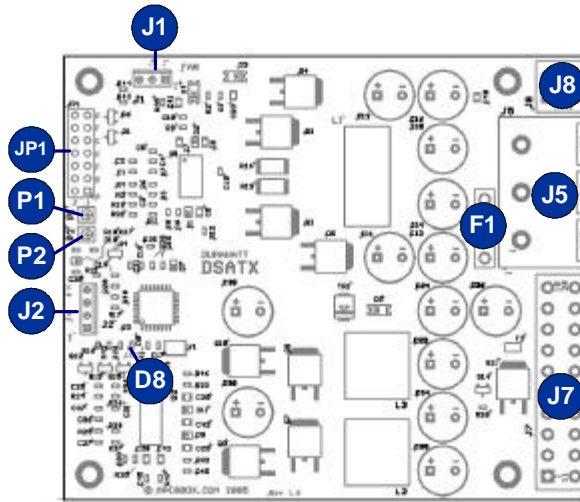

### Power Input

<b>J5</b>	Gnd:	Ground Input, connect to the chassis or the (-) battery terminal
	Vin:	+12 Volts Input, connect directly to the (+) battery terminal
	Acc:	Accessory Input, Connect to a switched +12 volt supply wire (ignition or fuse box)
<b>F1</b>	Input Fuse:	20-Amp mini-automotive fuse (yellow)

### Power Output

<b>J8</b>	ATX12V:	Connect to the 4-pin processor power connector on the motherboard
<b>J7</b>	ATXPWR:	Connect to the 20-pin motherboard power connector and peripherals
<b>J1</b>	FAN:	Connects to a 12 Volt 3-pin fan to cool the DSATX

### Control

<b>JP1</b>	Pins G1, G2:	Connects to Motherboard Power Switch Header (G2=Signal Output, G1=Gnd)
	Pins F1, F2:	Aux Connection (for Amp Enable or Slave Power Supply)
	Pins E1, E2:	<i>SL_SEN (RESERVED)</i>
	Pins D1, D2:	User Switch (will zero countdown timer when shorted)
	Pins C1, C2:	<i>User1 (RESERVED)</i>
	Pins B1, B2:	User0 (Shorting Jumper here enables Dumb PSU Mode)
	Pins A1, A2:	<i>A1=+5V, A2=nReset (RESERVED)</i>
<b>P1*</b>	Countdown Adj:	In Basic Mode, clockwise rotation adds time to the Countdown Timer (0-20m)
<b>P2*</b>	Low Voltage Adj:	In Basic Mode, clockwise rotation raises the low voltage threshold (10V-12V)
<b>D8</b>	LED indicator:	Indicates Operation, Timer States, and Faults
<b>J2</b>	Serial Port:	Enables Advanced Modes, field upgrades, and diagnostics

\*Note: Do Not Over-Turn P1 and P2, only 270 degrees is available

## 2.6. Bench Testing

The DSATX can be tested in the lab before being installed into the vehicle. Certain details need to be noted for proper bench testing. When connecting bench power use between 12 to 16 volts DC to Vin and Gnd terminals for best results. Small jumper wires may be sufficient to turn on the DSATX alone; however they will most likely not be adequate to run a computer. For the DSATX to turn on successfully, the bench supply must be able to provide 2 amps of inrush current. Under full rated load the DSATX draws around 18 amps @ 12V input. 12-volt bench top power supplies capable of delivering this kind of load are expensive and uncommon. Using 12 gauge or heavier wire will provide the best results. It is OK run a jumper wire from VIN to ACC for bench testing and certain installations.

To aid in bench testing, a Shorting Jumper at location JP1 pins B1 and B2 will enable Dumb Power Supply Mode. This will bypass the Startup/Shutdown sequencing and battery protection. ACC is not required and the LED will indicate that the DSATX is providing power on all the output rails.

The best way to do successful bench testing is to use an adequately sized 12V battery. Bringing in the battery from the car or using an extra one that has at least a 12-AmpHour capacity will be sufficient in most cases. Do not connect a Car Battery Charger directly to the DSATX.

Using the 12 volt output of an ATX AC-DC power supply is also a method for successful bench testing. By shorting the Green Wire (PS\_ON) of an ATX AC-DC power supply can provide the required current for certain bench testing applications. Make sure minimum load requirements (on the AC-DC power supply) are met if going this route.

## 2.7. Quick Installation Steps

- Connect GND, and VIN with heavy gauge wire directly to the automotive batteries + and - terminals. GND may also be connected with heavy gauge wire to the Chassis if desired.
- Connect the ATX Power Connector (J7/J8) to the Motherboard and any peripherals to the Molex Connectors.
- Connect a case fan with standard 3-pin connector to J1 FAN (or assure adequate air flow).
- Connect the ACC line to a switched 12 volt connection in the car (or through a switch to a constant 12 volt battery connection). This connection does not need to be heavy gauge.
- Connect a 2-pin jumper cable between location G at JP1 and the Motherboards "Power On" header. This will allow the DSATX to turn on and off the motherboard by simulating a power button press (POLARITY MATTERS HERE).
- Set P1 to set the time before shutdown. Adjustable between 0-20 minutes by default in Basic Mode.
- Set P2 jumper to set the low voltage cutout voltage. To minimize this feature, set it to 10 volts (fully counter clockwise). P2 is adjustable between 10-12 volts.
- Apply 12 volts to ACC by turning on the ignition or by flipping a switch and you're ready to go!

## 3. User Guide

### 3.1. Theory of Operation

The basic idea of the DSATX is this: You want to put a computer in your car, but you don't want to worry about turning it on and off, you don't want to worry about the temperature extremes, and you don't want to worry about the harsh automotive electrical environment. You also want to have the ability to go to the gas station and have the computer still running while you pump and pay so when you come back you don't have to wait a boot-up. When you get home, you don't want a dead battery. This power supply is the only one on the market that allows you to do all these things and have full control of the settings.

The following example will illustrate some of the features of Basic Mode and how it applies to an automotive install. The DSATX is installed as described above. The user steps into the automobile and turns on the key. ACC goes HI (12 Volts) as a result and the DSATX wakes up from Sleep Mode. The LED turns on and it sends a startup pulse to the motherboard over the 2-pin jumper connected at JP1 pins G1 and G2. The computer now boots and is up and the DSATX is in Running Mode playing Mp3s, doing GPS Navigation, etc. The automobile goes to the gas station and the driver turns off the key and ACC goes LOW. The DSATX now starts the Countdown Timer (Countdown Mode) and the LED starts flashing once per second. The driver gets back in the car, starts the car and the computer keeps playing the MP3s without a hiccup. The DSATX now is back to Running Mode with the LED full on. The user then drives home and turns off the car for the night. ACC goes low and the countdown timer starts and then expires. The DSATX then sends a pulse again over JP1 pins G1 and G2 to shutdown the computer. The shutdown pulse was successful and the computer turned off. The DSATX then goes to sleep and preserves battery power.

### 3.2. Modes of Operation

**Basic Mode:** This is the factory default mode for the DSATX. In this mode the following options are available:

- P1 and P2 adjustment pots are the only adjustable settings
- P1 adjusts the Countdown Timer, after ACC goes low the DSATX will wait between 0-20 minutes (10 minutes by default, P1= 50%)
- P2 adjusts the Low Voltage Cutout (10-12 Volts, 11 Volts Default, P2=50%)
- No Serial Port Adapter is required
- A switch connected at JP1 pins D1,D2 (User Switch) will allow a quick shutdown

**Extended Basic Mode:** This mode requires a **Serial Port Adapter** (see optional accessories above) to use. This mode is entered by typing an 'E' Character to enable the writing of parameters then a 'P' for Programming extended basic features. In this mode all the Basic Mode features apply as well as:

- P1 Countdown Timer range can be extended
- P1 and P2 adjustment pots can be bypassed and their values Hard Coded
- The VTURNON feature can be enabled allowing the DSATX to not send a startup pulse until the engine is running
- Parameters set via the Serial Port stay even when power is completely disconnected. They are stored in Non-Volatile Memory

**Advanced Mode:** This mode is simply going in and hard-coding various settings. Advanced setting adjustments include button press duration, deep-sleep disable, temperature range adjust,\* etc. These settings are accesses by using the "Get" and "Set" commands. See the Serial Port Section for more information.

\*Note: modifying the temperature settings to allow higher operating temperatures will void the manufactures limited warranty.

### 3.3. LED Codes

- OFF = System Off / Sleep Mode
- ON = Running Mode, the computer starts up in this mode (does not indicate computer is on)
- 1 blinks = Main Countdown Timer
- 2 blinks = Power Down (after shutdown pulse is sent)
- 3 blinks = N/A
- 4 blinks = Over or Under Temperature Condition. (Are you using a fan?)
- 5 blinks = Power Supply Overload or Fault (ACC must go low to clear a fault)

### 3.4. Basic Mode Timing Diagram

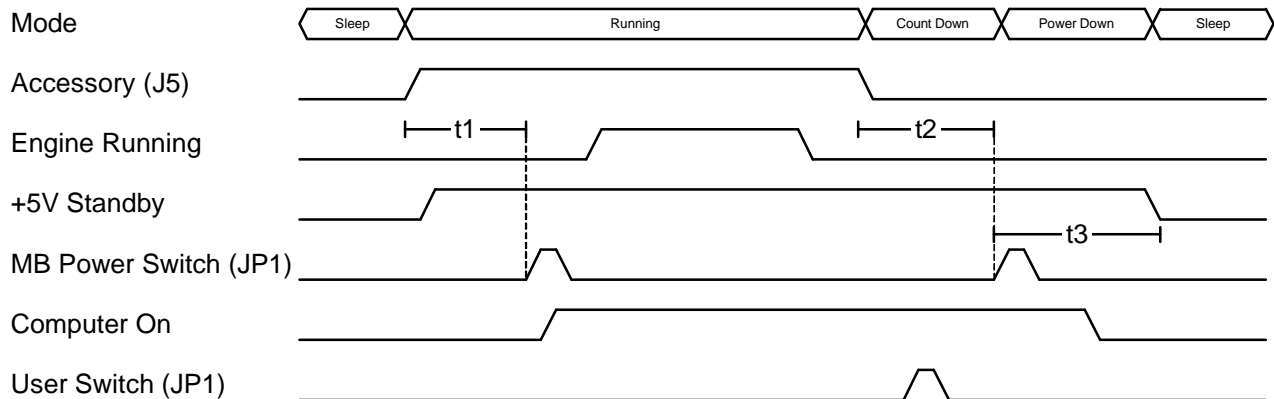

t1 = Time between ACC going High and the Computer Startup Pulse (TURNONDELAY). Default = 1s  
t2 = Time between ACC going Low and the Computer Shutdown Pulse (Set by P1). Default = 600s (P1=50%)  
t3 = Time between Computer Shutdown Pulse and +5V Standby OFF. Default = 90s Max, 2s Min

\*User Switch is optional. The DSATX only listens for User Switch during the t2 Countdown Mode (LED = 1 blink)

### 3.5. Features Explained

#### 3.5.1.Startup/Shutdown Sequencer

The DSATX is has the ability to turn on and turn off the computer via the JP1 pins G1,G2 connection. Connecting a 2-pin jumper wire will allow the DSATX to tell the motherboard to turn on and turn off by simulating a power button press. The DSATX knows if the motherboard is on or off and will only send the startup pulse if off and the shutdown pulse if on. This way the DSATX does not get into a weird state where it turns the computer on/off when it wasn't suppose to due to the user issuing a manual startup/shutdown.

#### 3.5.2.Input Voltage Monitoring and Engine Cranking

The DSATX is constantly monitoring the input voltage at the VIN terminal to make sure the conditions are right to be operating a computer motherboard in the vehicle. The DSATX will not initially turn on unless the voltage is above the value set by the P1 (or the serial adapter). Once the computer is up and running, the DSATX can survive engine cranking for up to 10 seconds. If the voltage at VIN is outside the allowable range, (battery too low) the DSATX will wait for sufficient charge before starting the computer and operating normally. The DSATX will survive engine cranking under the majority of normal use cranks. If the battery is too old or too depleted, there will be a point where no solution is capable of surviving engine cranking. Following the wire gauge and installation guidelines will provide the best results.

### **3.5.3. Input Transient, and Reverse Voltage Protection**

The DSATX has components that prevent the DSATX from being damaged from the harsh conditions present in a motor vehicle. Transients above 24 volts (Load Dump) are shunted by the protection components. Reverse voltage conditions will blow the fuse before damaging components on the DSATX.

### **3.5.4. Thermal Protection/Monitoring**

The DSATX is equipped with a temperature sensor that monitors the ambient temperature around the DSATX. The DSATX is programmed to only allow operation while the temperature is inside the window of -10c to 55c. If outside this range, the LED will flash 4 times and the DSATX will not provide power. Once the out of range condition goes away, the DSATX will behave like ACC was applied right at that point. This protects the DSATX, and the computer hardware from temperature extremes and potentially damaging over and under temperature conditions.

### **3.5.5. Output Voltage Protection/Monitoring**

The DSATX is constantly monitoring the Output Rails while operating. If the rails are ever overloaded, or shorted to ground or each other, the DSATX will detect that within 50ms and turn off all outputs and go into the "Fault" state. This will protect the computer hardware in the event that the DSATX is over loaded, or if the DSATX should fail for any reason. When rails are shorted, for example 5 volts to 12 volts, other power supplies on the market will not detect an over voltage condition, which will damage 5-volt rated computer components.

### **3.5.6. Output Current Limiting**

The output rails of the DSATX are designed to current limit such that they will begin to sag before the components are overloaded beyond their manufacturer rating in a way that could cause a fire or meltdown. The current limiting will be detected by the continuous output voltage monitoring and trigger a fault condition.

### **3.5.7. Sleep Mode/Battery Preservation**

When ACC goes low and stays low for a few seconds, the DSATX goes into low power Sleep Mode. In this state +5VSB is turned off (by default) and less than 4 mA is drawn by the DSATX. This will allow the DSATX equipped computer system to sit for weeks without depleting the battery. As soon as ACC goes high, the DSATX wakes from sleep mode. If ACC is always tied high, the DSATX will never enter sleep mode.

### **3.5.8. Start On Engine Running (VTURNON)**

When this feature is enabled with the serial adapter, the DSATX will not immediately turn on with ACC going high. ACC still needs to be connected as normal; however the DSATX will not turn on the computer until the voltage at VIN reaches 13 volts. This indicates that the alternator is charging the battery and the battery has sufficient charge to easily run the computer. This is useful if the system is approaching the upper limit of the DSATX's capability, or if the vehicle sits for a long time. It doesn't prevent cranking while running while going from the "Count Down" state back into the "Running" state, however the cranking while the vehicle has been sitting for a long time is the most likely to go below the 8 volt threshold of the DSATX. While the DSATX not surviving engine cranking is unlikely, some users like the piece of mind not worrying if "this crank" is going to be the one to cause a hiccup.

### **3.5.9. AUX Output Signal**

The connection at location JP1 F1,F2 can be used to provide a signal to an amplifier or auxiliary accessory or slave power supply (like the DSX12V) to come on after the Turn On pulse is sent. This is an open collector output at F1 and F2 is ground. A relay or transistor is required to deliver a 12 volt output at this location. This pin should sink no more than 50mA and has an allowable pull-up range of 0-25 volts.

## 4. Serial Port Connectivity

### 4.1. Serial Port Adapters

The DSATX was developed to be used with the serial hardware interface standard developed in the Robotics Industry by Acroname Inc. The DSATX is compatible with both the USB Serial Adapter and the RS-232 Serial Adapter.

- RS-232 DB-9 Adapter - PN: S13-SERIAL-INT-CONN
- USB B-Type Adapter - PN: S19-USB-SERIAL-INT-CONN

S13-SERIAL-INT-CONN

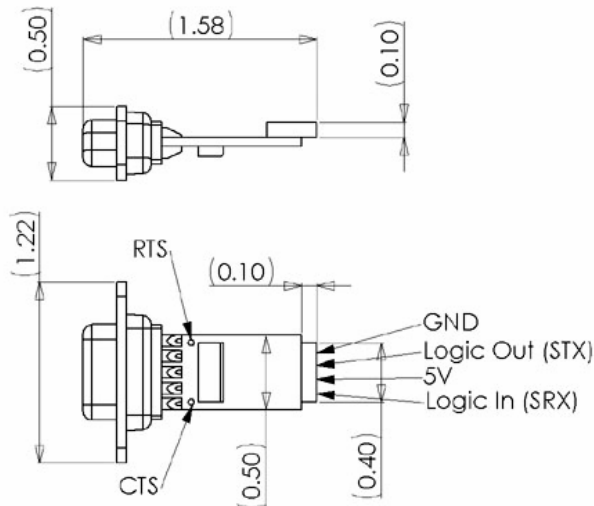

S19-USB-SERIAL-INT-CONN

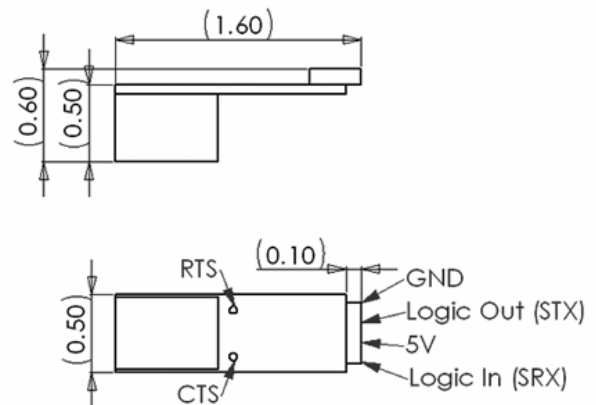

### 4.2. Serial Port Overview

DSATX Location J2 has a 4-pin header that matches the connection diagram on the above adapter drawings. The 5-Volt power comes from the DSATX and is always active even in sleep mode. Be careful not to expose the serial port pins of the DSATX to voltages above 5 volts or short out the pins. Connecting the Serial Port adapter backwards will not damage the DSATX or the adapter, but it will not function and is not recommended.

The serial port is setup to use 9600 Baud, 8 Data bits, No parity, 1 Stop bit, and no flow control (9600,8,N,1). Computer programs like HyperTerminal or TeraTerm are examples of applications that can be used to interface with the DSATX's Extended Basic and Advanced Modes. The USB adapter creates a virtual COMM Port.

### 4.3. Basic Programming Control

**The DSATX responds to the following commands over the serial interface (Case Sensitive):**

- E:** Enable Writing Parameters (Allows the below commands to work)
- P:** Enter Program Mode
- D:** Load Factory Defaults
- F:** Enable the printing of the serial diagnostic feed (**Feed On**)
- O:** Stop the printing of the serial diagnostic feed (**Feed Off**)
- Z:** Set the shutdown counter to 2 seconds (causes a quick shutdown in Countdown Mode)
- @:** Force a power button press, shutdown or startup (for testing JP1 G1,2 polarity)
- G:** (Advanced Feature) Get Parameter or Query
- S:** (Advanced Feature) Set Parameter

### 4.4. Diagnostic Feed

When the Diagnostic Feed is turned On, the DSATX has a diagnostic output that comes over the serial port output every 200ms. It includes the voltage of the input and outputs, the state of the controller, as well as some of the control signals. This is enabled by first typing '**E**' to enable writing, and '**F**' to enable the Feed. It is turned **Off** by typing '**O**'. These are case sensitive commands. The DSATX will remember the



last setting so if the Feed is turned off and then power is removed from VIN, the next time it powers up the Feed will be still be off.

### The Diagnostic Feed takes this format:

```
+030.3:12.56:12.00:05.19:03.34:10.49:0560:YNY:3:0558  
A : B : C : D : E : F : G : H :I: J
```

- A:** Ambient Temperature in Degrees C
- B:** Input Voltage at VIN
- C:** 12-Volt Rail Output
- D:** 5-Volt Rail Output
- E:** 3.3-Volt Rail Output
- F:** Low Voltage Threshold (P2 Adjusts this in Basic Mode)
- G:** Number of Seconds for main Shutdown Timer (P1 Adjusts this in Basic Mode)
- H:** Yes/No=Good/Bad : (VIN Voltage Good, Acc Pin High, Temp Good, PS\_ON Asserted)
- I:** State of Shut Down Controller:  
(0: Sleep, 1: Startup, 2: Running, 3: Count Down, 4: Shut Down)
- J:** Relative Count Value for Shutdown Counter (seconds)

## 4.5. Extended Basic Programming Examples

In the below example, we program the DSATX. Tell it to use the Pots (P1,P2) for the Timer1 (Main Countdown Timer) and the low voltage threshold cutout (P2 selects a value between 10 and 12 volts). Maxtimer1 is the maximum seconds you can set with the P1 Pot. Basically, if you set the pot half way and had Maxtimer1 set to 1200, it would shutdown in 600 seconds. If you set the Maxtimer1 to 0060 you would have between 0 and 60 seconds to select with the P1 Pot. You must type 4 numbers, Ex: 0123

```
>E           ← Type the letter E  
Enable Writing? y/n  
>y           ← Type the letter y  
>P           ← Type the letter P  
PROGRAM MODE  
Use POTs? y/n  
>y           ← Type the letter y  
MAXTIMER1:  
>1200       ← Type '1200' (must type 4 numbers)  
VTURNON? y/n  
>n           ← Type the letter n  
DONE
```

In the below example, we program the DSATX to hard code the values for the Timer1 (Main Countdown Timer) and the low voltage threshold. This will override P1 and P2 Pots. If you set LOWVOLTS to 1050, the unit wouldn't shutdown until it hit 10.50 volts on the VIN input. If you set Timer1 to 0600, then after 600 seconds of ACC going away, the computer will begin the shutdown sequence. We will also enable the VTURNON feature so the computer will turn on only after the engine is running.

```
>E           ← Type the letter E  
Enable Writing? y/n  
>y           ← Type the letter y  
>P           ← Type the letter P  
PROGRAM MODE  
Use POTs? y/n  
>n           ← Type the letter n  
LOWVOLTS:  
>1050       ← Type '1050' (must type 4 numbers)  
TIMER1:  
>0600       ← Type '0600' (must type 4 numbers)  
VTURNON? y/n  
>y           ← Type the letter y  
DONE
```

## 4.6. Advanced Features

For some users enough is never enough. The DSATX has the ability to fine tune many of the parameters that control its behavior. By using Set and Get commands ('S' and 'G') it is possible to read and write these parameters to the DSATX. To use the Set command, type at the prompt, an 'S' followed by 2 numbers for the index, followed by either 4 numbers or 1 number for the value.

Ex:

```
>S011130 ← Set parameter 1 (LOWVOLTS) to 11.30V
```

To use the Get command type 'G' at the prompt followed by the 2 number index.

Ex:

```
>G90 ← Get parameter 90 (Program Memory Version)
```

```
0108 ← Returns this result (1.08)
```

## 4.7. Advanced Feature Tables

The following tables show the available Parameter settings and Queries. Parameters will respond to the Set and Get command. Queries will only respond to the Get command.

Parameter	Index	Factory Default Value	Units	Description	Set By 'P' in Extended Basic Mode
LOWVOLTS	01	1100	10mV	Hard Coded Vin Low Battery Threshold (if USEPOTS =0)	Y
VINHIGHTHRESH	02	1300	10mV	Alternator "Turn on" Voltage Threshold	
HIGHVOLTS	03	1650	10mV	Vin Over Voltage Threshold	
VOLTSHYST	04	0045	10mV	Vin Voltage Hysteresis (Engine Cranking)	
VOLTSTHYST	05	1000	10ms	Vin Voltage High to Low Time Window (Engine Cranking)	
VOLTSTHYST1	06	0100	10ms	Vin Voltage Low to High Time Window	
TURNONDELAY	07	0100	10ms	Time To Wait After ACC High before sending turn on pulse	
PULSEWIDTH	08	0100	10ms	Motherboard Power Switch Press Duration	
MAXTIMER1	09	1200	1s	Maximum Countdown Time set by Potentiometer P1	Y
TIMER1EE	10	1200	1s	Hard Coded Countdown Time (if USEPOTS =0)	Y
TIMETOKILL	11	0090	1s	Time Allowed for Computer to Shut Down	
USEPOTS	12	1	1=yes, 0=no	If set, P1 and P2 set Countdown Time and Vin Low Battery Threshold	Y
ENABLESLEEP	13	1	1=yes, 0=no	If set, Unit Will go use Sleep Mode, ACC High for Wake Up	
FEEDON	14	1	1=yes, 0=no	If set, Serial Port Diagnostic Status Feed is Enabled	
VTURNON	15	0	1=yes, 0=no	If set, Mb Switch Press occurs after Vin is above VINHIGHTHRESH	Y
ACCTIMEVAL	16	0050	10ms	Settling time for the ACC input (Debouncing time)	
TEMPHIGH	17	0550	0.1 deg C	Maximum Operating Temperature	
TEMPLOW	18	0100	0.1 deg C	Minimum Operating Temperature (Can be Positive or Negative)	
TEMPHYST	19	0050	0.1 deg C	Temperature Stabilization Margin (Hysteresis to Prevent Oscillations)	
TEMPLOWSIGN	20	0	1=pos, 0=neg	Polarity of TEMPLOW (Minimum Operating Temperature)	
TEMPHYST	21	0200	10ms	Temperature Time Stabilization Window (Temp must stay good/bad)	
ENABLE5VSBOFF	22	1	1=yes, 0=no	Allows +5VSB Rail to Turn Off to Save Battery Life	
ENABLESHUTDOWN	23	1	1=yes, 0=no	Allows unit to Send the Motherboard Switch Press for Shutdown	
MASTERMODE	24	0	1=yes, 0=no	Allows DSATX to be cascaded with 2 or more DSATX for more Power	
EARLYAUXCUT	25	0	1=yes, 0=no	AUX will go away as soon as shutdown pulse is sent	

Query	Index		Units	Description
PlusVIN	40	N/A	10mV	The Current Voltage at the VIN terminal
Plus12	41	N/A	10mV	The Current Voltage on the 5V Rail
Plus5	42	N/A	10mV	The Current Voltage on the 12V Rail
Plus3_3	43	N/A	10mV	The Current Voltage on the 3.3V Rail
ActualTemp	44	N/A	0.1 deg C	The Current Temperature
TempSign	45	N/A	1=pos, 0=neg	The Current Temperature Polarity
LowVoltThresh	46	N/A	10mV	Current VIN Low Voltage Threshold (hardcoded or set by P2 between 10-12 volts)
CountDownTimerVal	47	N/A	1s	Current Countdown Timer Value (hardcoded or set by P1 between 0 and MAXTIMER1)
CurrentState	48	N/A	N/A	Current State: 0 = Wakeup, 1 = Startup, 2 = Running, 3 = Count Down, 4 Shut Down, 5 Sleep, 6 Bad Temp
MainCounter	49	N/A	1s	Current Value of Counter used when Counting Down to Switch States
P_VERSION	90	N/A	N/A	Flash Memory Version Number
E_VERSION	91	N/A	N/A	EEPROM Memory Version Number

## 5. Specifications

### 5.1. Electrical

#### Electrical Specifications:

Input Voltage (Operating)	6-24 Volts Non-Regulated
Input Voltage (Full Load)	8-16 Volts Non-Regulated
Input Current	20A (20A mini-blade fuse)
Output Power	220 Watts Max
No Load Operating Current	< 70mA
Sleep Current (All Rails Off)	< 4mA
Efficiency	> 95%

#### Individual Supply Outputs

#### Max Output Current

5.0 Volts +/- 2%	12 Amps Nominal, 13 Amps Peak
3.3 Volts +/- 2%	10 Amps Nominal, 11 Amps Peak
12.0 Volts +/- 2%	12 Amps Nominal, 15 Amps Peak
5.0 Volts Standby +/- 2%	1.5 Amps
-12.0 Volts +/- 10%	100 mA

#### Electrical I/O Specifications

ACC Input Threshold	Low = < 4V, High = >7V (30V Max)
ACC Input Impedance	100k Ohms
MB Power Switch Output Drive	Open Collector, 50mA Max
AUX Output Drive	Open Collector, 50mA Max
User Switch Pull-Up Drive	10k Ohms to 5V
Serial Port Rx/Tx	Low = < 0.7V, High = >2V (5V Max)

#### Supervisor Specifications (Basic Mode)

P1 - Countdown Timer Range	0-20 minutes (10 minutes default)
P2 - Low Voltage Cutout Range	10-12 volts (11 volts default)
Operating Temperature Range	-40 to +90 degrees Celsius
Controlled Temperature Range	-10 to +55 degrees Celsius
MB Turn On Delay	1 second
MB Power Switch Duration	1 second
Max Shutdown Timer Range	90 seconds

### 5.2. Mechanical

#### Mechanical Specification

Board Dimensions	4.15"L x 3.5"W x 1.0"H (106x99mm)
Mounting hole coordinates (in)	(0.2, 0.2) (0.2, 3.3) (3.5, 3.3) (3.5, 0.2)
Mounting hole size (in)	0.125
Board Thickness (in)	0.062

### 5.3. Connector Pin Diagrams

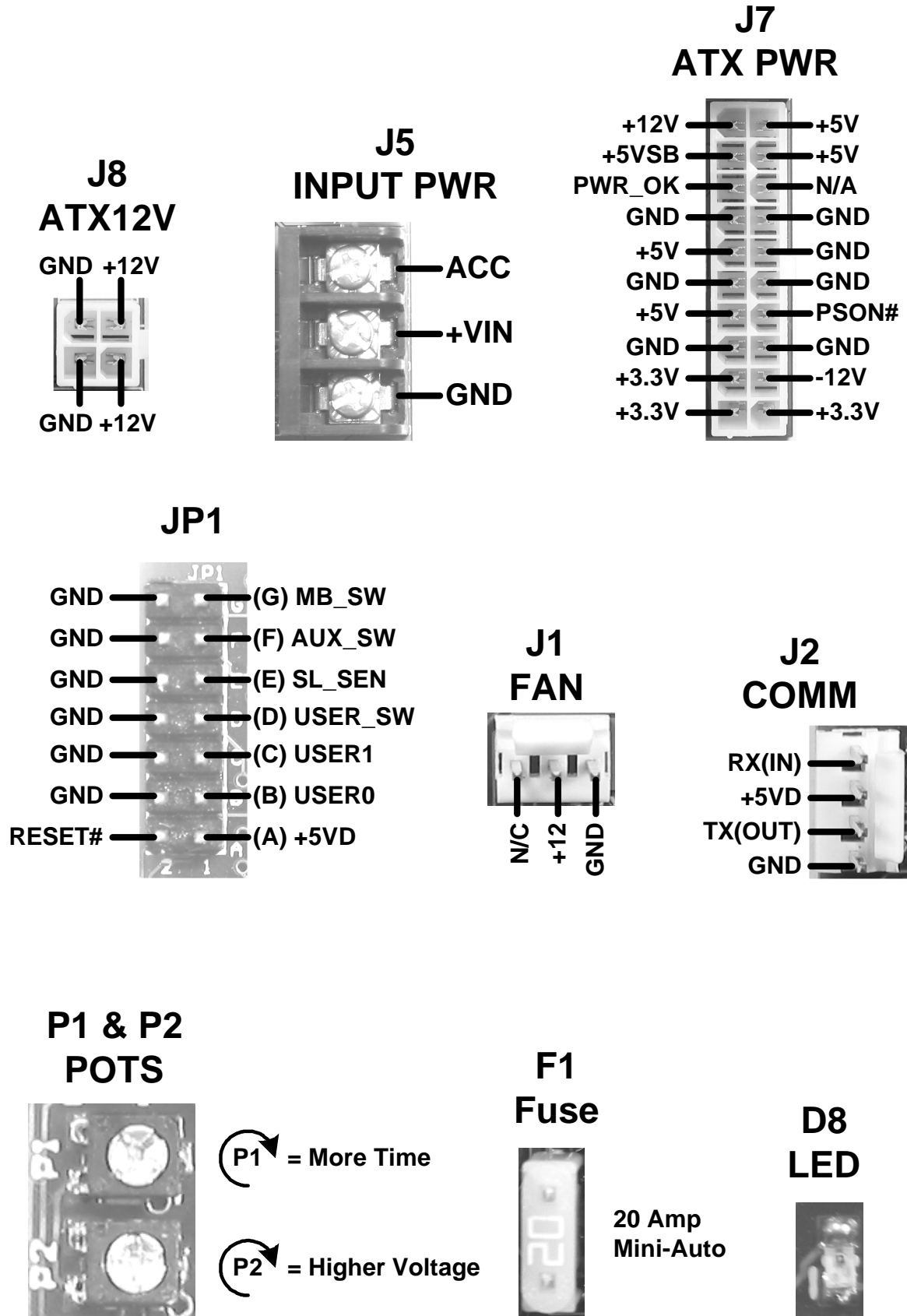

## 6. Troubleshooting

Please visit the [www.mpegbox.com](http://www.mpegbox.com) support forums for troubleshooting tips.

## 7. Mpegbox.com Limited Warranty

The DSATX Power Supply carries a Limited Warranty for the Period of 1 year from the date of purchase. Mpegbox.com warrants its products to be free from defects in workmanship and materials for a period of one (1) year from the date of purchase, Mpegbox.com will repair or replace the unit at our option, without charge for parts or labor. After the period of one year, the customer will be responsible for all charges for parts and labor. This limited warranty is extended only to the original purchaser. It does not cover any equipment connected to the DSATX or other consumable parts; transportation costs, or any damage incurred in transit. This warranty will become void if the serial number identification has been wholly or partially removed or altered. Repair or replacement under the terms and conditions of this warranty does not extend the term of this warranty. Any modification of the temperature control system parameters or modifications to the mechanical or electrical structure of this product will void this limited warranty.

A Return Material Authorization (RMA) must be obtained prior to returning the product by emailing [support@mpegbox.com](mailto:support@mpegbox.com). The RMA number must be marked on the outside of the shipping container and copy of a sales receipt or invoice must be included. Please include a brief description of the symptoms, your name, address, email and any other relevant instructions. Returns must be shipped prepaid in a static safe with adequate padding before returning to Mpegbox.com