

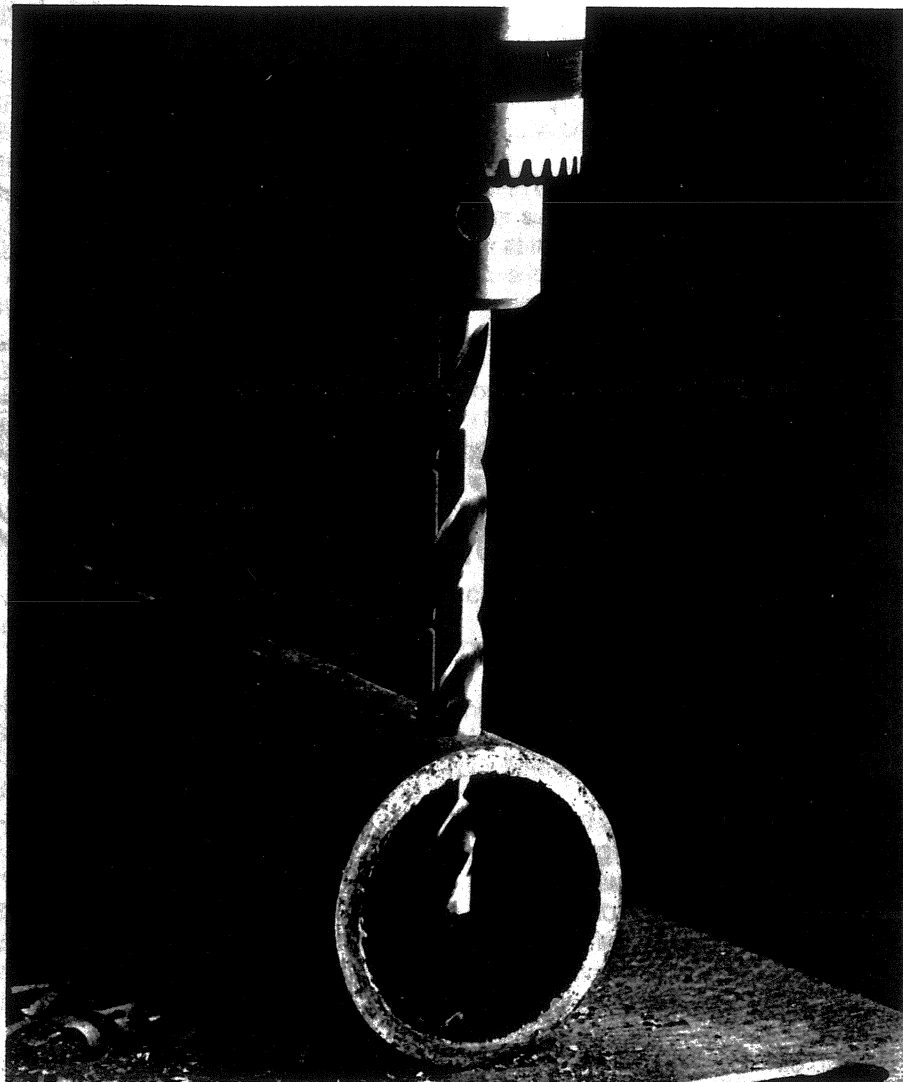

BLACK & DECKER™



Instruction Manual

**8" & 10" 5-Speed Drill Presses:
9400, 9401**

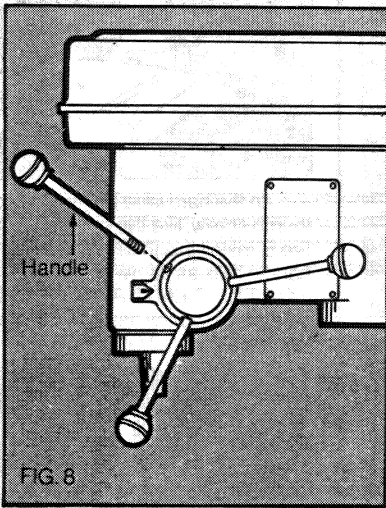
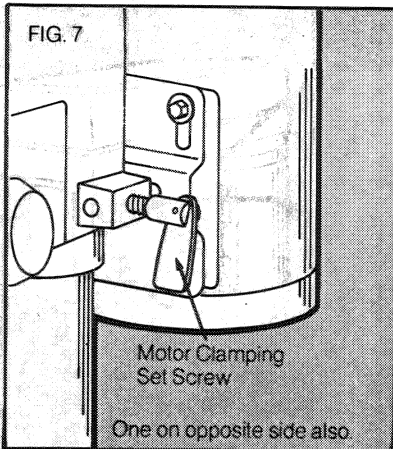

Install the three handles, as shown in Figure 8.

The small cardboard box stored with the plastic hardware bag contains the Chuck and Chuck Key. Before installing the chuck thoroughly clean the tapered spindle and the mating cavity in the chuck with kerosene or some other solvent to remove the oily residue on each surface. To install the Chuck, press it firmly up onto the tapered drive spindle.

You may tap it a few times with a plastic hammer to assure a firm fit. **DO NOT USE A STEEL HAMMER.** No threads are involved. **NOTE:** The Chuck Key has a built-in spring to keep it from being accidentally left in the chuck. Do not disable or circumvent this safety feature in any way. To do so will create a potentially hazardous condition.

Assembly (9400 only)

Using the three Column Bolts, install the Column assembly to the Base Plate, as shown in Figure 2. Figure 2 shows 4 Column Bolts. The 9400 Drill Press uses only 3 Column Bolts. Place the Base Plate/Column Assembly on a smooth, flat surface.

Install the Work Table down over the column, as shown in Figure 3. Insert the Table Clamping Handle into the collar at the back of the Work Table, as shown in the figure. Make sure that you insert the threaded end of the handle **THROUGH** the un-threaded side of the collar **BEFORE** engaging the threads. Position the Work Table about midway on the column and directly over the Base Plate.

Install the Motor and Drive Unit on top of the column and make sure that it fits firmly against the shoulder in the column. Position the drive spindle directly over the Work Table and tighten the hex screws in the side of the Motor and Drive Unit, as shown in Figure 4. (The hex wrench is in the plastic hardware bag.)

Install the three handles, as shown in Figure 8.

The small cardboard box stored with the plastic hardware bag contains the Chuck and Chuck Key. Before installing the chuck thoroughly clean the tapered spindle and the mating cavity in the chuck with kerosene or some other solvent to remove the oily residue on each surface. To install the Chuck, press it firmly up onto the tapered drive spindle. You may tap it a few times with a plastic hammer to assure a firm fit. **DO NOT USE A STEEL HAMMER.** No threads are involved. **NOTE:** The Chuck Key has a built-in spring to keep it from being accidentally left in the chuck. Do not disable or circumvent this safety feature in any way. To do so will create a potentially hazardous condition.

Motor and Drive Unit

Chuck

Work Table

UNIT SHOWN IS #9401

Controls (9401 only)

SWITCH: The switch is located on the left side of the drill press, as shown in Figure 9. To turn the tool "ON", flip the toggle forward (toward the operator) and to turn the tool "OFF", flip the toggle back. The switch will stay in either position without being held.

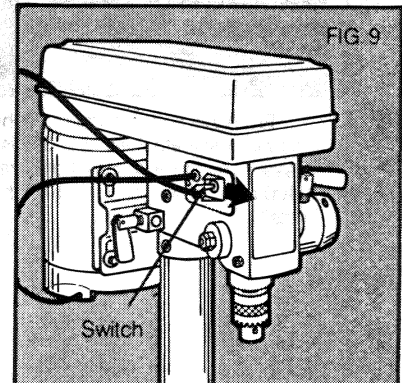

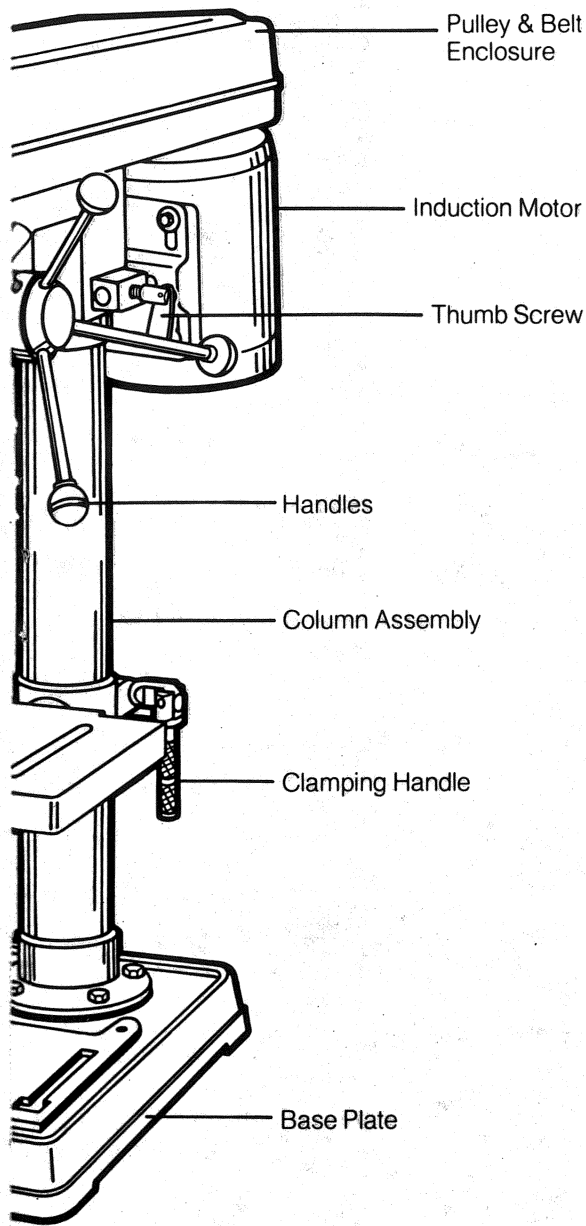

SPEED — DRIVE BELT ARRANGEMENT: Your drill press is capable of running at five different speeds, each one determined by the arrangement of the drive belt and pulley system inside the top of the Motor and Drive Unit. A handy chart that describes how to select a particular speed is attached to the inside of the drive belt cover. The chart is reproduced on page 9.

To select a speed, loosen the thumb screws on the sides of the motor housing (Figure 7) and slide the motor forward to loosen the drive belt. Adjust the belt as desired, referring to the chart and re-tighten the belt by pushing back on the motor as you tighten the thumb screws to clamp it in place. **NOTE:** It is not necessary to put great pressure on the drive belt. Just remove most of the slack. The belt should be able to slip in case the drill bit jams in the hole.

DRILLING DEPTH CONTROL:

You can control the depth of any holes you drill with the Drilling Depth Control feature. To set the drilling depth (from 0 to 2-1/2") place the tip of the drill bit in contact with the material to be drilled and loosen the Drilling Depth Control Lock Knob (see Figure 10A). Rotate the inner handle hub until the proper depth is displayed, as shown in Figure 10A. Depths are displayed by aligning the pointer with the appropriate mark on the inner hub. Each mark represents 1/8" of drilling depth. **NOTE:** Although 2-1/2" are indicated, the maximum drilling depth of which the drill is capable is 2-5/16"

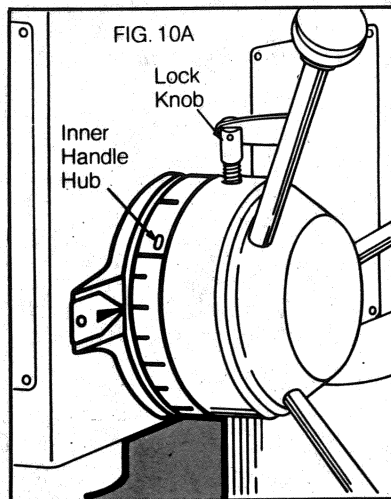

When you have selected the desired depth, tighten the Drilling Depth Control Lock Knob. When the drill bit reaches the set depth, it will continue to rotate but will drill no deeper.

Controls (9400 only)

SWITCH: The switch is located on the left side of the drill press, as shown in Figure 9. To turn the tool "ON", flip the toggle forward (toward the operator) and to turn the tool "OFF", flip the toggle back. The switch will stay in either position without being held.

SPEED — DRIVE BELT ARRANGEMENT: Your drill press is capable of running at five different speeds, each one determined by the arrangement of the drive belt and pulley system inside the top of the Motor and Drive Unit. A handy chart that describes how to select a particular speed is attached to the inside of the drive belt cover. The chart is reproduced on page 9.

To select a speed, loosen the thumb screw on the side of the motor housing (Figure 7) and pull the motor forward to loosen the drive belt. Adjust the belt as desired, referring to the chart and re-tighten the belt by pushing back on the motor as you tighten the thumb screw to clamp it in place. **NOTE:** It is not necessary to put great pressure on the drive belt. Just remove most of the slack. The belt should be able to slip in case the drill bit jams in the hole.

DRILLING DEPTH CONTROL:

On the left side of the Motor and Drive Unit is the Drilling Depth Control Assembly. To set the drilling depth (from 0 to 2"), first raise the chuck to its full up position. (It should do this automatically with spring pressure.)

Adjust, by hand, the depth pointer shown in Figure 10B so that it points to zero and rotate both hex nuts counter-clockwise until they are both up next to the pointer. Lower the chuck using one of the three handles to the desired depth. Hold the chuck in place while you screw down the lower hex nut on the Drilling Depth Control Assembly, as shown in Figure 10B. Screw the nut down until it contacts the boss protruding from the side of the Motor and Drive Unit shown in Figure 10B.

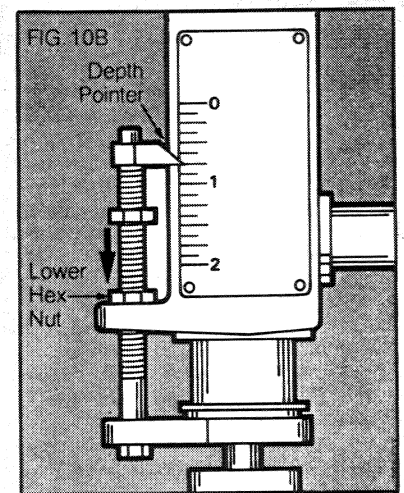

Lock the nut in place by screwing the top hex nut down against the lower one. Release the handle letting the chuck rise to its full height.

When you drill a hole and the lower hex nut "bottoms out" on the boss, the drill bit will continue to rotate but will go no deeper.

Additional Features (Both Tools)

TILTING THE WORK TABLE: The Tilting Work Table is designed to tilt up to 45° left and right and includes a precision scale marked in degrees from 0 to 45°, as shown in Figure 11A. To adjust the table to some angle other than 0° (horizontal), loosen the large bolt located under the Work Table, as shown in Figure 11B. This takes a 3/4" wrench, but a socket will make it a little easier.

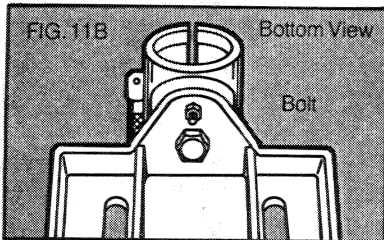
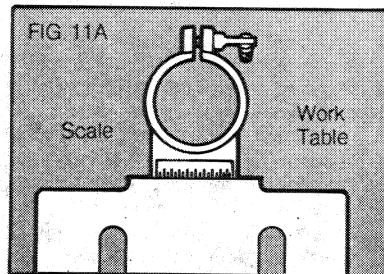

After loosening the bolt, turn the small hex nut next to it **CLOCKWISE** (as if you were tightening it). This will draw out the lock pin that holds the table in the horizontal position. Keep turning the nut until the lock pin can be pulled out of the drill press by hand. Put the pin in a safe place . . . you won't need it as long as you are using the tilting table feature.

Tilt the table as desired and align the "0" mark on the table with the appropriate mark on the scale. Tighten the 3/4" bolt to hold the table at the desired angle.

To insert the lock pin again after you have returned the table to the horizontal position, remove the hex nut from the pin, insert the pin as far as it will go and screw the hex nut back onto the pin until it just touches the Work Table. With the lock pin engaged, securely tighten the 3/4" bolt.

ROTATING WORK TABLE: For drilling applications where you need a little extra height, the Work Table can be rotated out of the way by loosening the table clamping handle and pushing the table to one side. This allows you to clamp the workpiece to the Base Plate and, thus, get a little more height for taller workpieces.

ROTATING MOTOR AND DRIVE UNIT: The Motor and Drive Unit rotates about the column in order that you may drill objects that are off the table such as that shown in Figure 12. To rotate the Motor and Drive Unit, use the hex wrench provided and loosen the hex screw that clamps the Motor and Drive Unit to the column. Rotate as desired and re-tighten the screw.

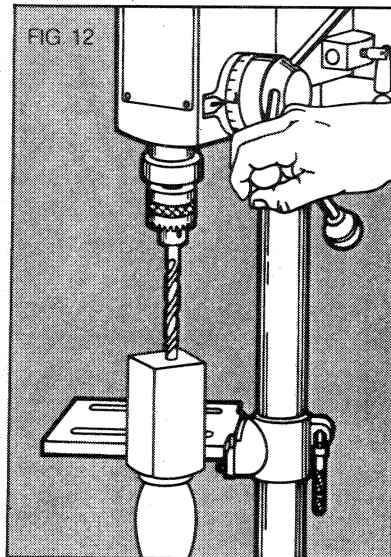

Bench Mounting (Both Tools)

We strongly recommend that you firmly mount your drill press to a solid workbench or other rigid frame. Two holes are provided in the base for this purpose. Use large wood screws if mounting to wood or appropriate machine screws and nuts if mounting to metal.

To enhance the tool's portability, it can be mounted to a piece of 5/8" or thicker plywood which can, in turn, be "C" clamped to your work surface as shown below.

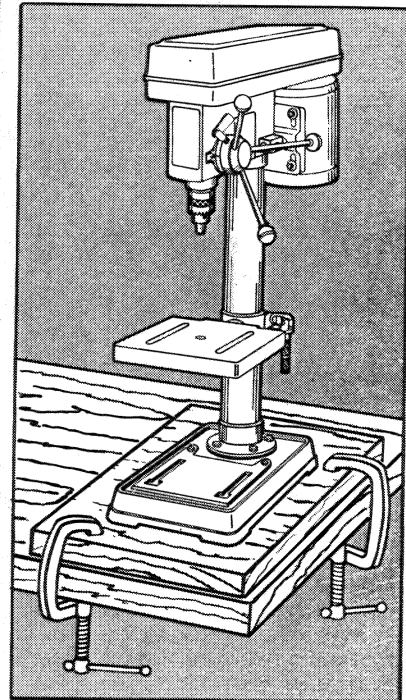

Speed Selection (Both Tools)

The five speeds of which your drill press is capable will handle almost any drilling project you may encounter. Generally speaking, you should use lower speeds for drilling in metals and higher speeds for drilling in wood and wood compositions. Use the Speed Selection Chart as a guide in determining the best drilling speed for your application. Always experiment in scrap material if possible.

As a general rule you should drill pilot holes for metal drilling (except when using hole saws). Also use cutting oil with most metals except cast iron and brass which should be drilled dry.

When using a twist bit for drilling wood or wood compositions, it will be necessary to pull the bit from the hole frequently to clear chips from the flutes.

Care should be exercised when drilling plastics to avoid melting them.

Material Being Drilled	Type of Drill Bit	Speed Setting #9400 RPM	Speed Setting #9401 RPM	Comments
Metal; Ferrous & Non-Ferrous	High Speed Steel Twist Bit	450 or 730 RPM	620 or 1100 RPM	Generally the low speeds are best for drilling metal.
Metal; Ferrous & Non-Ferrous	Hole Saw	450 or 730 RPM	620 or 1100 RPM	Generally lower speeds are best. Hole saws are noisy.
Ceramics, Masonry, Glass	Carbide Bit	450 RPM	620 RPM	Use very low speeds and light pressure.
Plastics & Laminates	High Speed Steel Twist Bit	450 or 730 RPM	620 or 1100 RPM	Use care to avoid melting.
Plastics & Laminates	Hole Saw	450 or 730 RPM	620 or 1100 RPM	Use care to avoid melting.
Wood & Wood Compositions	High Speed Steel Twist Bit	1330, 2170 or 3000 RPM	1720, 2340 or 3100 RPM	Remove bits from hole often to remove chips.
Wood & Wood Compositions	All Other Bits (Spade, Auger, Hole Saw)	1330, 2170 or 3000 RPM	1720, 2340 or 3100 RPM	

	SPINDLE RPM	CHUCK	MOTOR
9400	3100	████████	████████████████
	2340	████████	████████████████
	1720	████████	████████████████
	1100	████████	████████████████
	620	████████	████████████████
9401	3600	████████	████████████████
	2610	████████	████████████████
	1600	████████	████████████████
	880	████████	████████████████
	540	████████	████████████████

Operation (Both Tools)

ALWAYS WEAR EYE PROTECTION. TURN OFF AND UNPLUG DRILL PRESS WHEN MAKING ANY AND ALL ADJUSTMENTS.

- Clamp Work** — Always clamp the workpiece to the Work Table or other supporting surface. Use "C" clamps, bar clamps, cinch clamps or any other device you can find to solidly anchor the workpiece.
- Insert the desired drill bit into the chuck as far as it will go and then pull it back out about 1/16". Tighten the chuck with the key in all three holes. (It is important to tighten in all three holes.)
- Make sure that the switch is **OFF** and plug the tool in. Turn the drill **ON**.
- Using one of the three handles, lower the drill bit into the workpiece, as shown in Figure 13.

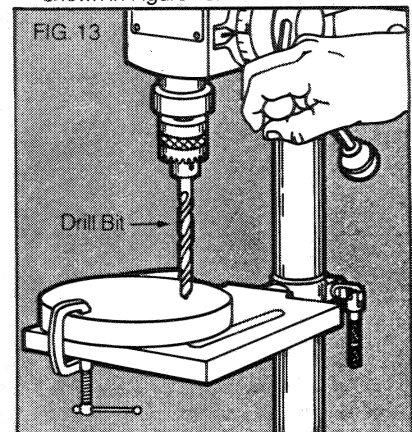

These four steps constitute the actual drilling of a hole. Of course before you start step 1, you have selected the proper speed, set the drilling depth control, positioned the work table so that the desired drilling depth can be attained (not too low), and centerpunched the position of the hole to be drilled.

One final point — Remember to drill in the center of the Work Table so that the drill bit will pass harmlessly through the clearance hole.

As you work more and more with your drill press, you'll become comfortable with it and many of these instructions will become second nature to you. There will be times when you don't set the optimum speed or adjust the drilling depth. These things are available when they're needed but there are certainly times when they just aren't necessary.

These shortcuts are fine but, **DON'T BYPASS SAFETY.** Periodically go back and review the safety rules to refresh your memory.

Extension Cords (Both Tools)

Tools that have 3-wire cords requiring grounding must only be used with extension cords that have 3-prong grounding type plugs and 3-pole receptacles. Only round jacketed extension cords should be used, and we recommend that they be listed by Underwriters Laboratories (U.L.). If the extension will be used outside, the cord must be suitable for outdoor use. Any cord marked as outdoor can also be used for indoor work. (The letters "WA" on the cord jacket indicate that the cord is suitable for outdoor use.)

An extension cord must have adequate wire size (AWG or American Wire Gauge) for safety, and to prevent loss of power and overheating. The smaller the gauge number of the wire, the greater the capacity of the cable, that is 16 gauge has more capacity than 18 gauge. When using more than one extension to make up the total length, be sure each individual extension contains at least the minimum wire size.

To determine the minimum wire size required, refer to the chart below:

CHART FOR MINIMUM WIRE SIZE (AWG) OF EXTENSION CORDS								
NAMEPLATE RATING - AMPS	TOTAL EXTENSION CORD LENGTH - FEET							
	25	50	75	100	125	150	175	200
0 - 10.0	18	18	16	16	14	14	12	12
10.1 - 13.0	16	16	14	14	14	12	12	12
13.1 - 15.0	14	14	12	12	12	12	12	—

Before using an extension cord, inspect it for loose or exposed wires, damaged insulation, and defective fittings. Make any needed repairs or replace the cord if necessary. Black & Decker has extension cords available that are U.L. listed for outdoor use.

NOTES

Black & Decker's Full Two Year Home Use Warranty states that, in case of a defect, you may return the tool to the place of purchase for a free replacement (if it is a participating retailer) or you may take it to a Black & Decker Service Center.

Home Use Warranty (A Full Two Year Warranty)

Black & Decker warrants this product for two years against any defects that are due to faulty material or workmanship. Please return the complete unit, transportation prepaid, to the seller (if a participating retailer) for free replacement (proof of purchase may be required). The unit may also be returned to a Black & Decker Service Center or Authorized Service Station listed under "Tools Electric" in the Yellow Pages for free replacement or repair at our option. This warranty does not apply to accessories. This warranty gives you specific legal rights and you may have other rights which vary from state to state. Should you have any questions, contact your nearest Black & Decker Service Center Manager.

Like all Black & Decker tools, your Drill Press is listed by Underwriters' Laboratories to ensure that it meets stringent safety requirements.



This symbol on the nameplate means the product is listed by Underwriters' Laboratories, Inc.



See 'Tools-Electric'
—Yellow Pages—
for Service & Sales



BLACK & DECKER™

Distributed by BLACK & DECKER (U.S.) INC., U.S. Power Tools Group, 10 North Park Drive, P.O. 21030-0798, Hunt Valley, MD 21030 U.S.A.

Form No. 741234
(JUL87) ©1987 Printed in Taiwan
Product Made in Taiwan